

ENGINEERING  
TOMORROW



User Guide

# Motor / Generator

## EM-PMI240-T180



## Revision history

*Table of revisions*

Date	Changed	Rev
May 2024	Sections updated: Product naming convention, Shaft alignment and load, Storage, Condition monitoring during operation	0202
July 2021	Updated user guide	0201

## Contents

### General information

Intended use of the user guide.....	5
Product naming convention .....	5
Conformity according to standards.....	6
Warranty.....	7
Terms and abbreviations.....	7
Responsibility of the manufacturer.....	8

### Safety information

General safety statement.....	9
Safety message signal words.....	9
Safety symbols.....	9
Personal protective equipment.....	10
Security features.....	10
Electromagnetic compatibility (EMC).....	11

### Product overview

Intended use of the electric machine.....	12
Used technology.....	13
System introduction.....	14
Connections and interfaces.....	15
Rating plate.....	16
Tightening torques.....	18

### Design principles

System design.....	19
Cooling and temperature measurement .....	19
Insulation lifetime.....	19
Inverter.....	20
Mounting structure.....	21
Supporting structure requirements.....	21
Shaft alignment and load.....	22

### Transportation and storage

Transportation.....	25
Receiving and unpacking.....	25
Lifting.....	25
Storage.....	27
Extended storage.....	28

### Installation

Required tools.....	30
Insulation resistance test.....	30
Mechanical installation.....	30
Allowed mounting positions.....	30
Mounting the electric machine.....	31
Cooling connections.....	33
Electrical installation.....	33
Power connections.....	33
High voltage connection.....	33
Connection diagram.....	35
Low voltage connections.....	36
Grounding connections.....	38

### Operation

Operation conditions.....	40
Condition monitoring during operation.....	41
Recommended lubricants.....	41
Recommended coolants.....	42
Emergency operation.....	42

### Maintenance

## Contents

Regular maintenance.....	44
Cleaning.....	45
Bearings and lubrication.....	46
Cooling system maintenance.....	48

## Dismounting

## Troubleshooting

## Aftersales

Service policy.....	52
---------------------	----

## Disposal

## Storage, installation and maintenance checklists

## General information

### Intended use of the user guide

This user guide contains instructions necessary to safely and properly handle, install, operate and maintain the electric machine. They should be brought to the attention of anyone who installs, operates or maintains the machine or associated equipment.

All of the safety warnings and instructions in this user guide must be followed to prevent injury to personnel or damage to property. Only qualified and authorized personnel, familiar with health and safety requirements and national legislation, shall be permitted to handle, install, operate and maintain the device.

This user guide must be kept for future reference during installation, operation and maintenance.

This user guide uses illustrations as examples only. Illustrations in this user guide may not necessarily reflect all system features.

### Product naming convention

In this user guide, EM-PMI family permanent magnet motors and generators are referred to as the electric machine.

Frame model indicates dimensions and electrical characteristics of the electric machine. The following naming convention is used to refer to the electric machine frame model:

- EM-PMI240-T180-XXXX+XX

#### *The naming codes of the electric machine*

Part of the name	Meaning
EM	Electric Machine
PMIXXX or PMEXXX	Permanent Magnet Internal and a number relative to the diameter of the electric machine, or Permanent Magnet External and a number relative to diameter of the electric machine
TXXXX	Average continuous torque of the motor range, relative to the length of the machine
XXXX	Rated rotation speed
+XX	Options. Standard options are indicated by a star (*).

The power input of the machine may require one or several three phase power systems. This is indicated by a power connection option marking, for example: DUAL or QUAD in the machine model code. One three phases power system can include one or three connection boxes in the machine. The most usual case is when an electric machine has a single connection box, but this is not shown in the machine model code.

The electric machine can include some of the options available. The options of the electric machine are shown also in the rating plate, following the frame model code. Note! Only options that differ from the standard delivery are indicated. For detailed information on the models, options and characteristics, see product-specific data sheet.

#### *EM-PMI240-T180 options*

Variant	Code	Description	Additional information
Drive-end shaft	*	Male shaft	DIN 5480 W40x2x18x8f
	+S2	Female shaft, spline	14 tooth spline 12/24 pitch (ANSI B92.1B 1996 - Class 6e)

## General information

### EM-PMI240-T180 options (continued)

Variant	Code	Description	Additional information
D-end attachment	*	Standard flange	SAE 6, transmission housing
	+DE1	Flange interface for hydraulic pump	SAE C, 4 bolt mating transmission housing
Mounting direction	*	Only horizontal assembly	With standard bearing option
	+MA	Can be used in any direction	Requires greased for life bearings (+BGL)
Bearing lubrication and mounting direction	*	Grease lubricated	Deep groove ball bearing, open design, horizontal mounting direction
	+BGL	Greased for life	Deep groove ball bearing, contact seal on both sides, any mounting direction
Protection class	*	IP65 protection class	
	+IP67	IP67 protection class	Requires greased for life bearings (+BGL)
Rotation sensor (resolver)	*	None	No resolver
	+RES1	Resolver	Inbuilt non-contacting resolver, 4-pole pair
Winding temperature sensors	*	Temperature surveillance	3 x PT100 (two wire) in windings
	+TEMP4	Redundant temperature surveillance	6 x PT100 (two wire) in windings (requires +LVB1)

(\* Standard option)

## Conformity according to standards

The electric machine has been designed to be in conformity with the following directives and to meet the requirements specified in the following standards:

### Applicable Directives and standards

Standard	Explanation
Low Voltage Directive 2006/95/EC (until 19.4.2016) and Low Voltage Directive 2014/35/EU (from 20.4.2016 onwards)	Electrical equipment means any equipment designed for use with a voltage rating of between 50 and 1000 V for alternating current. This electric machine is subject to the Low Voltage Directive 2006/95/EC or 2014/35/EC.
IEC 60034-1:2010	Rotating electrical machines - Part 1: Rating and performance
IEC 60034-5:2001/A1:2007	Rotating electrical machines - Part 5: Degrees of protection provided by the integral design of rotating electrical machines (IP code) - Classification
IEC 60034-6:1991	Rotating electrical machines - Part 6: Methods of cooling
IEC 60034-7:1992/A1:2001	Rotating electrical machines - Part 7: Classification of types of construction, mounting arrangements and connection box position (IM Code)
IEC 60034-8:2007/A1:2014	Rotating electrical machines - Part 8: Terminal markings and direction of rotation
IEC 60034-14:2004/A1:2008	Amendment 1 - Rotating electrical machines - Part 14: Mechanical vibration of certain machines with shaft heights 56 mm and higher - Measurement, evaluation and limits of vibration severity.

It should be noted, that the commissioning party is responsible for establishing the conformity of the end product with the Directive 2006/42/EC, when the EM-PMI electric machines are fitted into machinery.

## General information

### Warranty

Danfoss offers warranty against defects in workmanship and materials for its products for a period of twelve (12) months from commissioning or eighteen months (18) from delivery (Incoterms-EXW), whichever occurs first.

In order for the warranty to be valid, the customer must follow the requirements of this and all related documents, especially those set out in the product installation and maintenance, as well as the applicable standards and regulations in force in each country.

Defects arising from the improper or negligent use, operation, and/or installation of the equipment, non-execution of regular preventive maintenance, as well as defects resulting from external factors or equipment and components not supplied/recommended by Danfoss, will not be covered by the warranty.

The warranty will not apply if the customer at its own discretion makes repairs and/or modifications to the equipment without prior written consent from Danfoss.

### Terms and abbreviations

The symbols, terms and abbreviations in the Tables below are possibly used in this manual.

#### Symbols

Symbol	Variable	Unit
$U$	Rated voltage (phase-to-phase AC)	$V_{rms}$
$I$	Rated current (AC)	$A_{rms}$
$P$	Rated Power (S1)	kW
$T$	Rated torque (S1) at rated speed	Nm
$T_{max}$	Maximum torque	Nm
$n$	Rated speed	rpm
$Max\ n$	Maximum speed	rpm
$f$	Rated supply frequency at nominal speed	Hz
$PF$	Power factor ( $\cos\phi$ )	
$Q_c$	Rated coolant liquid flow	l/min
$T_c$	Rated coolant liquid input temperature	$^{\circ}C$
$T_{amb}$	Rated ambient temperature	$^{\circ}C$
$RES\_COS$	Cosine signal received from the resolver	deg
$RES\_SIN$	Sinusoidal signal received from the machine resolver	deg
$\Omega$ (Ohm)	Resistance	$\Omega$

#### Term / abbreviation

Term/ Abbreviation	Explanation
Resolver	Rotation meter in electric machines, used for measuring degrees of rotation
AC	Alternating current
DC	Direct current
GND	Ground in electrical connections
PMSM	Permanent Magnet Synchronous Machine
SRPM	Synchronous Reluctance assisted Permanent Magnet
S1	Duty type according to the IEC60034; Continuous running duty
S9	Duty type according to the IEC60034; Duty with non-periodic load and speed variations

## General information

### Responsibility of the manufacturer

Danfoss is responsible for the safety, reliability and performance of the electric machine only if:

- Handling, mounting, installation, operation and maintenance are done by qualified and authorized personnel.
- The installation of the system complies with the requirements of the appropriate regulations.
- The electric machine is used in accordance with the instructions in this user guide.
- The electric machine is installed, maintained and serviced in accordance with the instructions in this user guide.



## Safety information

### General safety statement

- The electric machine is intended for use as a component for industrial and commercial installations. The end product containing the electric machine must conform with all related regulations.
- The use of the electric machine is prohibited in hazardous areas unless it is expressly designed for such use.
- The electric machine is intended for installation, use and maintenance by qualified personnel, familiar with health and safety requirements and national legislation. Ignoring these instructions may invalidate all applicable warranties.
- These instructions must be followed to make sure of safe and correct installation, operation and maintenance of the electric machine. They should be brought to the attention of anyone who installs, operates or maintains the electric machine or associated equipment.
- High voltage and rotating parts can cause serious or fatal injuries. For electric machine covered by this user guide, it is important to observe safety precautions to protect personnel from possible injury.

### Safety message signal words

Safety message signal words indicate the severity of a potential hazard.

**DANGER** Indicates an imminently hazardous situation which, if not avoided, will result in death or serious injury.

**WARNING** Indicates a potentially hazardous situation which, if not avoided, could result in death or serious injury.

**CAUTION** Indicates a potentially hazardous situation which, if not avoided, may result in minor or moderate injury. CAUTION may also alert against unsafe practices.

**NOTICE** Indicates a potentially hazardous situation which, if not avoided, could result in property damage.

### Safety symbols

The following safety and information related symbols appear in this user guide and on the electric machine.

	<p><b>Danger</b> This symbol is identified by a yellow background, red octagonal band and a black STOP text. It indicates a hazardous situation that causes severe injury or death. Action indicated by this symbol may not be executed.</p>
	<p><b>General warning</b> This symbol is identified by a yellow background, black triangular band, and a black exclamation point symbol. It indicates a general potentially hazardous situation.</p>
	<p><b>Electric shock warning</b> The symbol is identified by a yellow background, black triangular band, and a black arrowhead symbol. It indicates dangerous electrical voltage that could cause an electric shock to a person.</p>
	<p><b>Burn warning</b> The symbol is identified by a yellow background, black triangular band, and a black wavy lines symbol. It indicates a hot device that could cause burns to a person. The symbol also indicates that the device should be placed and installed so that contact with its potentially hot surface is not possible.</p>

## Safety information

	<p><b>Magnet warning</b> The symbol is identified by a yellow background, black triangular band, and a black magnet symbol. It indicates strong magnetic field that could cause harm to a person or property.</p>
	<p><b>Rotating shaft warning</b> The symbol is identified by a yellow background, black triangular band, and a black rotating shaft symbol. It indicates strong rotating shaft that could cause harm to a person or property.</p>
	<p><b>General Information.</b></p>
	<p><b>Read the instructions in the user guide.</b></p>

## Personal protective equipment

Personal protective equipment shall be used when necessary during handling, installation and maintenance of the electric machine to avoid injury.

	<p><b>Use eye protective equipment like safety goggles or mask when you work with the electric machine. Permanent damage to the eye could be caused if bearing grease, melted nitrile rubber (radial lip seal), glycol or other fluids splash.</b></p>
	<p><b>Use hearing protective equipment when you work on the electric machine. Hearing injuries can be caused by too loud noise (noise in excess of 85 dBA).</b></p>
	<p><b>Use head protective equipment like helmet when you lift the electric machine! Head injuries can be caused by object impact.</b></p>
	<p><b>Use cut resistant gloves when you handle and maintain the electric machine. There is a risk of cut injuries.</b></p>
	<p><b>Use protective footwear when you lift or move the electric machine! Foot injuries could be caused if lifting system or lifting brackets fail.</b></p>

## Security features

The electric machine has at least one PT100 temperature sensor in the windings. The amount of the sensors depends on the options chosen. The temperature signal(s) can be read out from the

## Safety information

measurement connector of the electric machine. You can connect the temperature signal to the temperature surveillance pin in the inverter (EC-C) and make sure that the inverter has the machine temperature protection feature activated.

### Electromagnetic compatibility (EMC)

	<p><b>When interfacing other equipment, connect only equipment that are specified as part of the system and that are compatible.</b></p>
	<p><b>Magnetic and electromagnetic fields generated near the current-carrying conductors and permanent magnets in electric machines represent a health danger to persons with heart pacemakers, metal implants and hearing aids. Persons with a heart pacemaker, metal implants or hearing aids must consult a doctor before they enter the following areas:</b></p> <ul style="list-style-type: none"> <li>• <b>areas in which electric equipment and parts are operated</b></li> <li>• <b>areas in which electric equipment with permanent magnets are stored, mounted, operated or repaired</b></li> </ul> <p><b>If necessary, perform a special electromagnetic compatibility (EMC) test on the installation.</b></p>

EMC stands for Electromagnetic compatibility. It is the ability of electric equipment to operate without problems within an electromagnetic environment. Likewise, the equipment must not disturb or interfere with any other product or system within its locality. This is a legal requirement for all equipment taken into service within the European Economic Area (EEA).

Our products are designed with high standards of EMC in mind. Connect the power lines and groundings along the instructions in this user guide to achieve the required level of EMI protection.

It is the responsibility of the installer to make sure that the equipment or system into which the product is incorporated complies with the EMC legislation of the country of use. Within the European Union, equipment into which this product is incorporated must comply with the EMC Directive 2014/30/EU.

## Product overview

	<p><b>For harsh conditions, like salty air in marine applications, it is recommended to check the surface treatment possibilities with the factory.</b></p>
--	---

The electric machines have been developed especially for heavy duty, marine and transportation applications. They are more reliable, smaller, lighter and more efficient than conventional products on the market.

Typical applications of the electric machines are:

- Motor (electric propulsion) and generator for hybrid marine vessels or mobile work machines and bus parallel hybrid applications.
- Traction motor and generator for electrical or hybrid electrical mobile work machines or buses.

The electric machines feature Synchronous Reluctance assisted Permanent Magnet (SRPM) motor technology, having several advanced features:

- Extremely compact and robust structure.
- High efficiency throughout the operation range.
- Liquid cooling with water-glycol mixture.
- Low coolant flow required.
- High allowed coolant temperature.
- IP65/IP67 enclosure class to maximize reliability.
- Multiple mounting possibilities.
- Extended speed and torque capabilities compared to standard PM machines.
- Machine structure designed to be able to produce high starting torques (instant torque to non-moving wheel).
- Optimized speed range to meet most common gear ratios used in heavy mobile machinery.

*The electric machine*

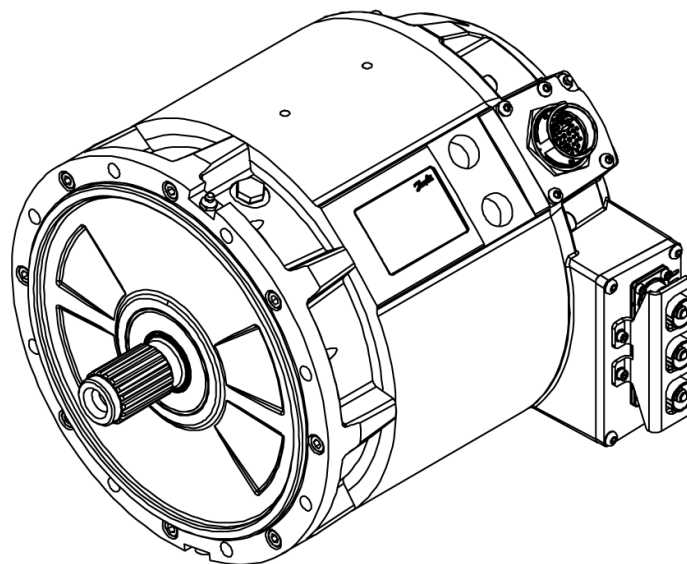

### Intended use of the electric machine

This electric machine is intended to be used as a motor or generator and as a part of a machinery, for example in:

## Product overview

- Power train of a marine vessel, transportation vehicle or a heavy duty work machine.
- Power generation equipment.

The electric machine is intended to be powered and controlled with an inverter or inverters capable of supplying three-phase alternating current and that is capable of controlling the electric machine. The electric machine is not suitable for direct online use.

In a power generation equipment the electric machines are intended to be powered by a prime mover, for example, an internal combustion engine and controlled by the above mentioned electric power inverter.

The electric machine is solely intended for professional use, and may be operated only by trained professionals. The maintenance of the electric machine may be done only by trained professionals.

### Forbidden use of the electric machine

It is forbidden to use, handle and maintain the machine in following ways (including but not limited to):

- Using the electric machine for other purposes than defined in this user guide.
- Disregarding the obligation to comply with the user guide, safety signs and rating plate of the electric machine.
- Using the electric machine, making adjustments and maintenance without first reading this user guide.
- Exceeding the designed limits during the electric machine operation.
- Using non-original service parts of wrong material causing corrosion problems and mechanical failures in time.
- Operating and performing maintenance for the electric machine without appropriate personal protective equipment.
- Using electric machine parts like frame, shaft end or terminal box for climbing or for support for other structures.
- Causing any kind of impact forces to the electric machine (for example hitting or hammering or dropping objects).
- Operating the electric machine with electric connections other than defined in the user guide and/or other documents.
- Operating the electric machine with insufficiently tightened connections or cable glands.
- Operating the electric machine with power cables routed against the instructions.
- Operating the electric machine without properly dimensioned and operating cooling system.
- Operating the electric machine without following the bearing lubrication instructions.
- Touching the connection terminal of the electric machine or doing maintenance or adjustment operations on the electric machine with the electricity connected.
- Accessing the connection box(es) if the shaft can be turned by an external prime mover.
- Lifting the electric machine from wrong lifting points and without correct lifting equipment.
- Lifting additional load with the machine.
- Storing the electric machine outdoors in wet or dusty conditions.
- Storing the electric machine without correct support to prevent rolling or falling of the machines.
- Using the electric machine in potentially explosive environment.
- Allowing dirt or liquid to enter into the electric machine or connection box.
- Using cables that cannot withstand the maximum currents of the electric machine.

## Used technology

The electric machine is a Synchronous Reluctance assisted Permanent Magnet (SRPM) machine. This technology has several benefits compared to standard permanent magnet (PM) technology and traditional induction machine (IM) technology. The SRPM technology combines the benefits of PM and Synchronous Reluctance technology, having increased torque capability over wide speed range and ability to produce torque to higher speeds. The electric machine efficiency at lower speeds is also good.

## Product overview

The supply current to the machine stator windings create rotating magnetic field, which in turn rotates the rotor containing permanent magnets. In the synchronous permanent magnet machine, the rotation of the rotor (shaft) is synchronized with the frequency of the power supply current. The reluctance technology maximizes the pull-out torque of the machine.

The permanent magnets of the rotor are of salient-pole design, having embedded permanent magnets in the rotor structure. This structure makes the electric machine mechanically more stable and capable of higher speed operations. See Figure below illustrating the magnet topology of the electric machine. The Figure shows the principle only, and is not an exact illustration of the structure.

*Machine topology*

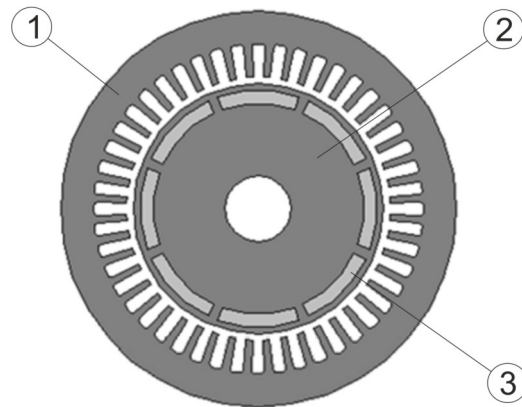

1	Electric machine stator and stator windings
2	Electric machine rotor
3	Permanent magnets in the rotor

## System introduction

Danfoss provides electric drive trains for applications in heavy mobile work machines, marine vessels and buses. The drive trains include all essential components for converting from traditional to hybrid electric (HEV) or electric vehicle (EV) solutions. Danfoss technology saves fuel and lowers emission and noise levels.

*Overview of the Danfoss drive train system*

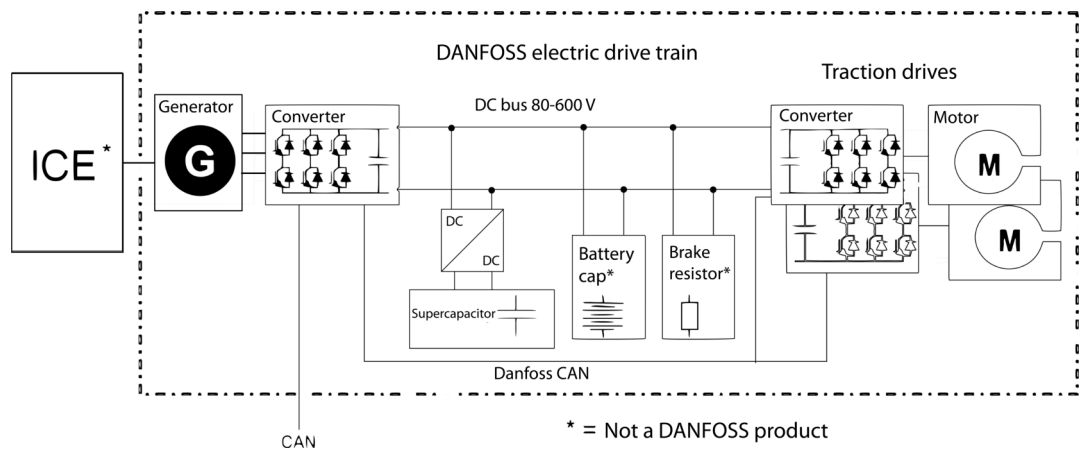

The electric machines are liquid cooled with water-glycol mixture. For more information, see Chapter [Cooling connections](#).

## Product overview

A low voltage measurement signal connector is attached to the electric machines. Different temperature and resolver signals can be read, depending on the machine options chosen. For more information about the connection, see Chapter [Low voltage connections](#).

*Overview of electric machine system*

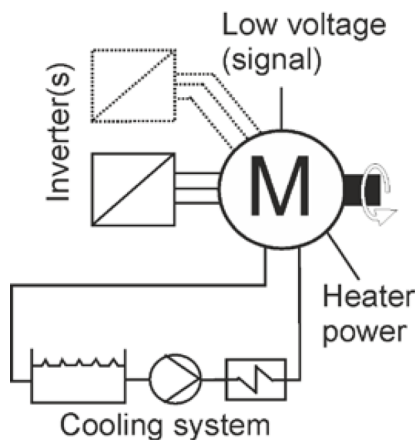

## Connections and interfaces

The electric machines are connected mechanically and electrically as a part of a machinery or as a part of a power generation equipment.

Mechanical interfaces:

- Lifting points.
- Flange mounting (D-end and N-end).
- Shaft connection(s).
- Cooling system connections (bores).
- Grease escape/fill connections; depending on model and option (+BHS): maintenance use only.
- Air ventilation plug.

Electrical interfaces:

- Power connections.
- Measurement connections.
- Low voltage (measurement signal) grounding connection.
- Power grounding connection.

**Product overview**

*Connections and interfaces*

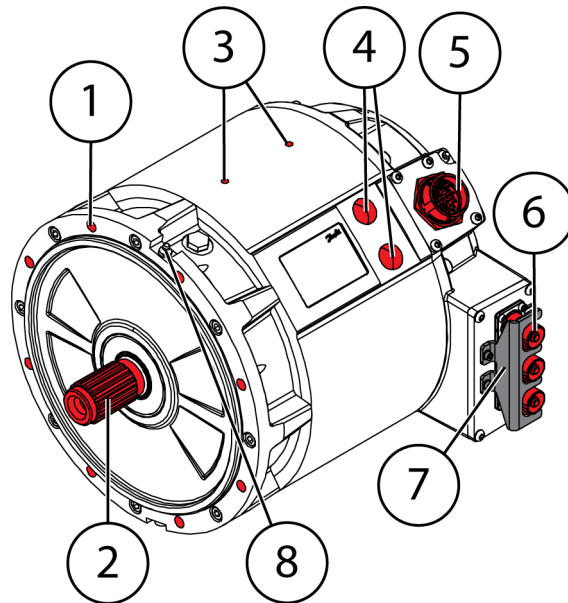

1	D-end mounting holes, 8 pcs (diameter 11 - THRU)
2	Shaft connection DIN5480 Spline W40x2x18x8f
3	Lifting holes, 2 pcs. M8x1.25 (15 mm deep). They can be used for grounding.
4	Cooling liquid bores G 3/4
5	Low voltage connector DEUTSCH HD34-24-47PE
6	Phase connections AMPHENOL HVBI005R10AMHARD
7	Connector locking plate (mechanical safety feature)
8	Bearing grease nipple - option dependent (both bearings have one)

**Rating plate**

Each electric machine has a rating plate which can be found on the machine frame. The rating plate contains machine rating and identification. The rating values in the Figure below are not correct for this machine. See the rating plate on the machine and data sheets for the correct values.



## Product overview

### Rating plate

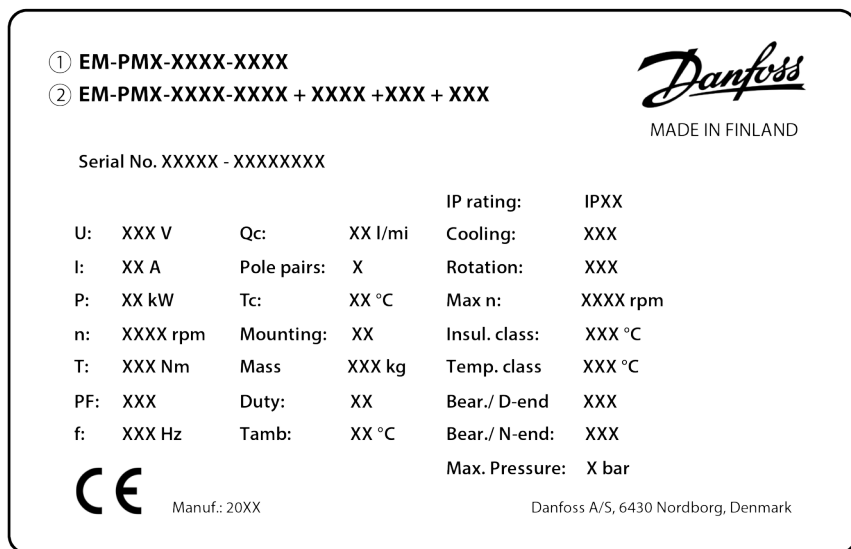

### Rating plate fields

Field	Explanation	Unit
1	Electric machine product family: EM-PMI or EM-PME	
2	Electric machine type code and options	
Serial No.	Serial number	
U	Rated voltage (phase-to-phase AC)	V <sub>rms</sub>
I	Rated current (AC)	I <sub>rms</sub>
P	Rated power (S9) according to IEC60034-1	kW
n	Rated speed	rpm
T	Rated torque (S9) at rated speed	Nm
PF	Power factor	
f	Rated supply frequency at nominal speed	Hz
Q <sub>c</sub>	Rated coolant liquid flow	l/min
Pole pairs	Number of magnetic pole pairs of the machine	
T <sub>c</sub>	Rated coolant liquid input temperature	°C
Mounting	Allowed mounting position according to IEC60034-7	
Mass	Mass of the electric machine	kg
Duty	Defined rotating electric machine duty cycles by IEC60034-1 standard	
T <sub>amb</sub>	Rated ambient temperature	°C
IP rating	Enclosure class according to IEC60034-5	
Cooling	Cooling method according to IEC60034-6	
Rotation	Direction of rotor rotation with default phase order. Observed facing the D-end.	
Max n	Maximum rotation speed	rpm
Insul. class	Temperature rating (class) of insulation of the electric machine according to IEC60034-1	
Temp. class	Temperature rating (class) of individual insulation materials of the insulation according to IEC60034-1	

## Product overview

### Rating plate fields (continued)

Bear. / D-end	Bearing type (types) in the D-end of the electric machine	
Bear. / N-end	Bearing type in the N-end of the electric machine	
Max. pressure	Cooling liquid max pressure	
CE	CE marking	

## Tightening torques

	<b>Tightening torque tolerance is +/- 5% of the specified tightening torque, unless otherwise stated.</b>
	<b>Use threadlocking adhesive for RST, that is, stainless steel bolts to avoid breakage.</b>
	<b>Do not install dry screws or other fastening equipment. Add suitable lubrication, for example Wuerth HSP 1400, to prevent excess friction.</b>

### Tightening torques to use unless otherwise noted

	8.8	10.9	12.9
Thread	Nm	Nm	Nm
M5	7	10	11
M6	11	17	19
M8	27	40	47
M10	54	79	93
M12	93	137	160
M14	148	218	255
M16	230	338	395

## Design principles

This Chapter describes design principles that must be taken into account when designing the system using the electric machine.

## System design

### Cooling and temperature measurement

	<b>Do not operate the electric machine without correctly dimensioned and operating cooling system.</b>
	<b>Mount the electric machine in correct position, see Chapter <a href="#">Allowed mounting position</a>.</b>
	<b>When you connect the cooling system make sure that the cooling medium flows freely in and out from the electric machine with the cooling medium flow equal or higher than rated.</b>
	<b>The cooling medium temperature at the inlet of the electric machine must be lower or equal to the rated temperature.</b>

See more detailed information about coolant connection bore specifications, required coolant liquid flow and other specifications in the product data sheet. Rated values can be found from the electric machine rating plate.

The electric machine has at least one PT100 temperature sensor in the windings. The amount of the sensors depend on the options chosen. The temperature signal(s) can be read out from the measurement connector of the machine.

The maximum allowed winding temperature of the electric machine is shown in the rating plate and in the data sheet.

The PT100 temperature sensor characteristics are: resistance 100  $\Omega$  at 0°C temperature, and the resistance increases 0.385  $\Omega$  per each 1°C increase of temperature.

### Insulation lifetime

	<b>Heat cycles, environment, moisture, vibrations and similar variables have an effect on the lifetime expectancy of the insulation of the electric machine. The value of the insulation lifetime expectancy is a calculated value and it is not tested in practice.</b>
--	--

The insulation of the electric machine has the following lifetime expectancy.

Insulation class	Lifetime expectancy
F (150°C)	20 000 h
H (175°C)	20 000 h 100 000 h if driven with maximum winding temperature of 150°C

## Design principles

### Inverter

The electric machine is intended to be powered and controlled with an inverter capable of supplying three-phase alternating current and that is capable of controlling the electric machine. The electric machine is not suitable for direct online use.

If the electric machine is driven with an inverter from a supplier other than Danfoss Editron, the electric machine performance may differ from rated values. The optimum performance of the electric machine is obtained with Danfoss Editron inverters. These inverters are:

- Compact and light.
- Liquid cooled.
- Tolerant to high mechanical vibration (10 G) and shock (50 G).
- Efficient, efficiency > 98 %.
- Reliable, no moving components.



**Do not exceed the maximum rotation speed of the electric machine.**

EC-C1200



## Design principles

Schematic of the inverter powerstage

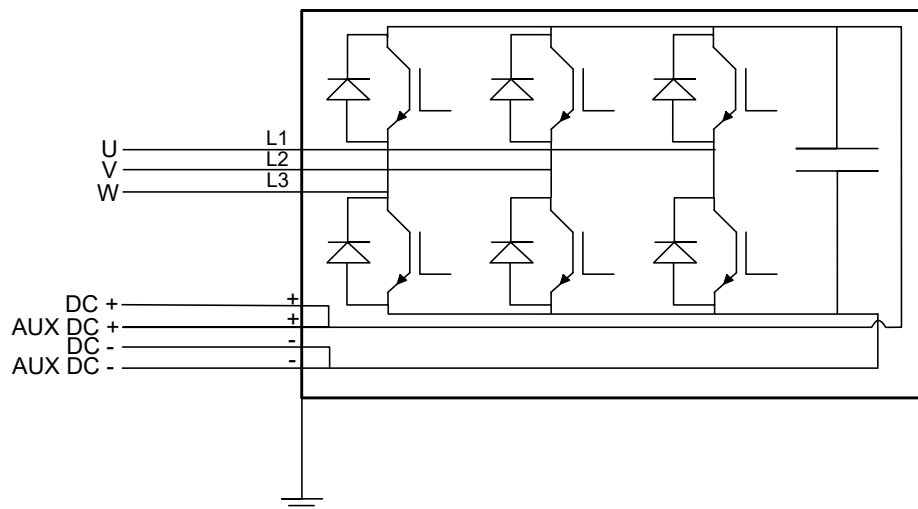

The main machine power driving parameters are shown in the machine rating plate. For more information, contact Danfoss representative.

You can connect one of the temperature signals (from the low voltage connector) to the temperature surveillance pin in the inverter and make sure that the inverter has the machine temperature protection feature activated.

## Mounting structure

### Supporting structure requirements



**Do not install the electric machine near or in direct contact with easily flammable materials. The surface of the electric machine can be hot.**

The mating housing arrangement of the electric machine must be secure and sufficiently rigid to prevent vibrations and mechanical failures. Necessary actions should be taken to avoid corrosion on the mating housing arrangement.

The supporting structure for the electric machine must be such that the electric machine can be mounted using its allowed mounting positions, see Chapter [Allowed mounting positions](#).

The mounting space must be adequate for the electric machine mounting and possible auxiliary components. See the length and the diameter data of the electric machine from the product drawing. Main dimensions of the electric machine are shown in the Figure below (the illustration may differ from the actual electric machine).

## Design principles

### Main dimensions of the electric machine

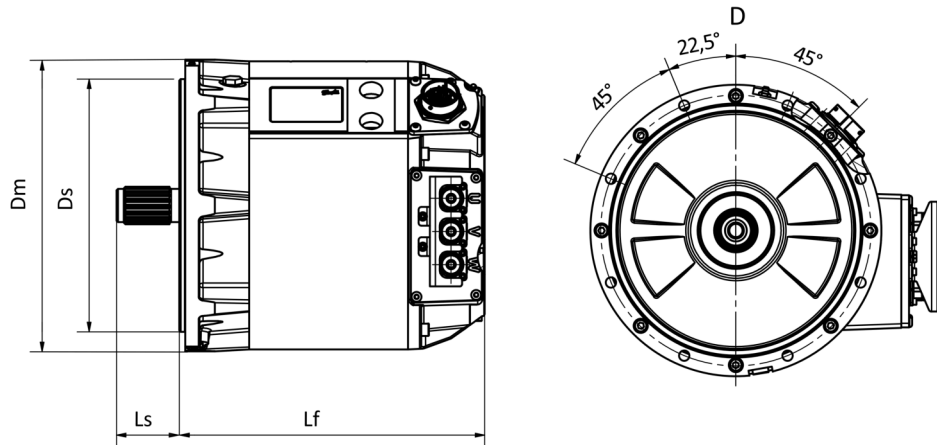

Symbol	Explanation
$L_f$	Length of the electric machine frame (including the connection box(es)).
$L_s$	Length of the shaft (from the end of the shaft to the electric machine D-end mounting shoulder).
$D_m$	Diameter of the flange mounting bore circle.
$D_s$	Diameter of the mounting shoulder.

For all dimensions of the electric machine, see the product drawings.

### Shaft alignment and load



**Improper alignment (misalignment) may result in bearing overloads, premature bearing failures, vibrations and shaft failures. Use of flexible coupling is recommended. Flexible coupling does not compensate for excessive misalignment, so proper alignment needs to be ensured regardless of used coupling type.**

The type of electric machine shaft is DIN 5480 SplineW40x2x18x8f. Recommended female connection counterpart is of type SAE 6 Mating transmission housing flange.

Alignment between the shaft and mating structure must be accurate. Flexible coupling does not compensate for excessive misalignment.

The misalignment can be parallel or angular misalignment, or combination of those. With parallel misalignment, the center lines of both shafts are parallel but they are offset. With angular misalignment, the shafts are at an angle to each other. Figures below illustrate the parallel and angular misalignment.

#### Parallel alignment of the shaft and mating structure

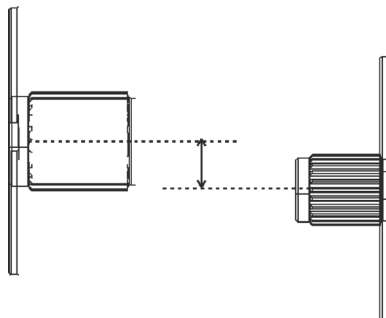

## Design principles

### Maximum parallel misalignment values

	Non-flexible coupling *	Flexible coupling *
rpm	mm	mm
0-1000	0.07	0.13
1000-2000	0.05	0.10
2000-3000	0.03	0.07
3000-4000	0.02	0.05
4000-6000	< 0.02	0.03

\* The values given might differ between coupling types.

### Angular alignment of the shaft and mating structure

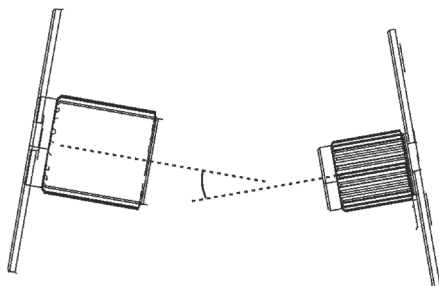

### Maximum angular misalignment values

	Non-flexible coupling *	Flexible coupling *
rpm	mm / 100 mm	mm / 100 mm
0-1000	0.06	0.10
1000-2000	0.05	0.08
2000-3000	0.04	0.07
3000-4000	0.03	0.06
4000-6000	< 0.03	0.05

\* The values given might differ between coupling types.



The maximum external force directed to the shaft axially and radially may not exceed machine specific values. For more information, see document DOC-000454. Calculate the relevant values with the help of the document. Contact Danfoss service at <https://danfossedatron.zendesk.com/hc/en-gb> or send email to [editron.service@danfoss.com](mailto:editron.service@danfoss.com) to obtain the document.

## Design principles

*External shaft forces of the electric machine*

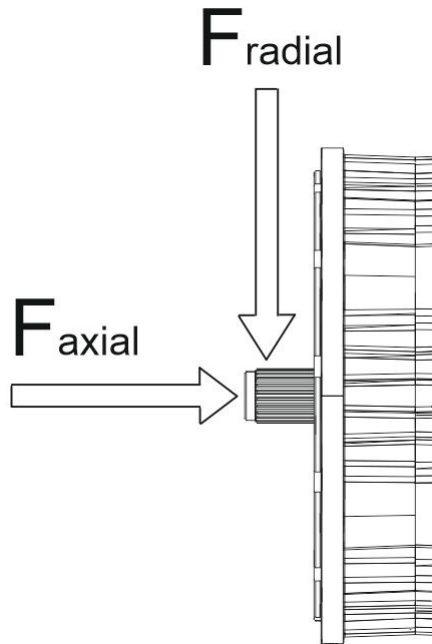



## Transportation and storage

### Transportation

	<p><b>Heavy equipment. Handle with care during transportation.</b></p>
--	--

Electric machine is shipped in first class condition. It has been inspected and packed correctly to prevent damage from ordinary handling during shipment. During transportation, shocks, falls and humidity should be avoided. Protect the cooling holes for transportation.

The weight of the electric machine can be found on the machine rating plate, and in the product data sheet.

### Receiving and unpacking

	<p><b>Do not touch the electric machine during the insulation resistance check. Discharge the electric machine afterwards.</b></p>
	<p><b>Do not touch the electrical terminals when the rotor is rotated. The electrical terminals have dangerous voltage during rotation. Contact Danfoss representative if the rotor can not be rotated.</b></p>
	<p><b>Remove the transportation supports of the electric machine.</b></p>

### Check upon arrival and unpacking

- The electric machine and the package must be inspected immediately upon arrival. Make sure that the rating plate data in the cover letter complies with the purchase order. Any external damage (in shaft-ends, flanges, electrical interfaces and paint) must be photographed and reported immediately.
- Remove any shaft locks and rotate the shaft. It is normal for the rotation of the shaft to be difficult.

### Lifting

	<p><b>Use correct, adequately dimensioned lifting devices and inspect them before lifting.</b></p>
	<p><b>Do not lift from the shaft of the electric machine!</b></p>

Transportation and storage

	<p><b>Do not apply any excess weight on the electric machine when lifting.</b></p>
	<p><b>Use correct lifting slings. Use correct position and angle of lifting.</b></p>
	<p><b>See the electric machine rating plate for weight information.</b></p>
	<p><b>Lift the electric machine using the correct lifting lugs/eyes only.</b></p>
	<p><b>Do not go under a lifted load.</b></p>
	<p><b>Lifting slings cannot touch the electric machine during the lifting.</b></p>

*Lifting lugs/eyes/points for lifting slings and lifting position of the electric machine*

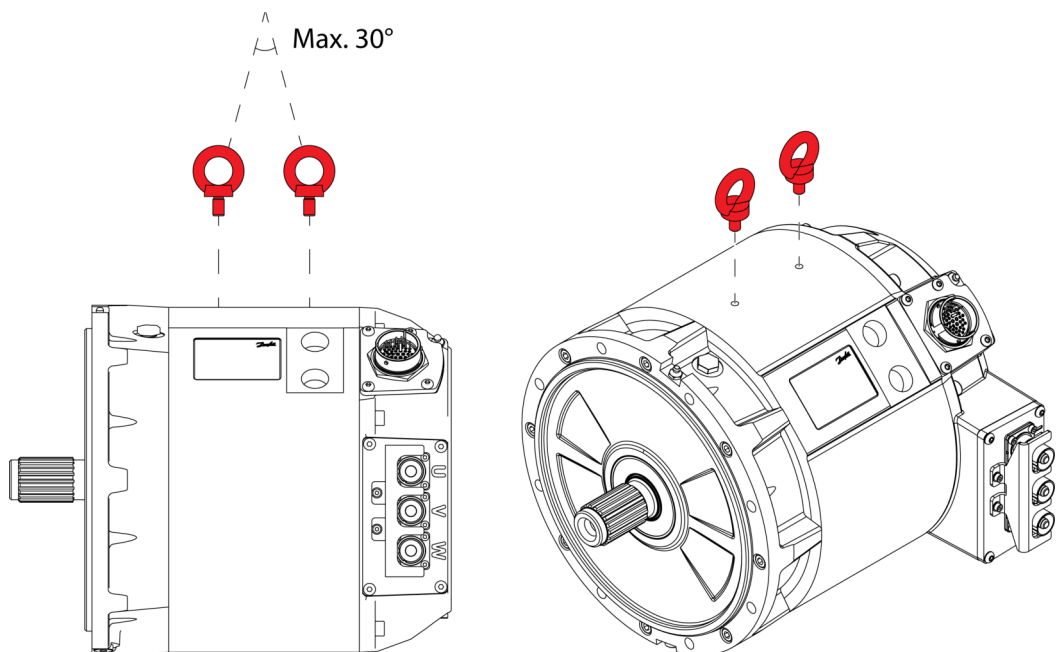

Lifting eye type: RS M8 0,20t (2 pcs)

## Transportation and storage

### Horizontal lifting

Install 2 pieces of lifting eyes to the lifting bores of the electric machine frame. Mount the lifting eyes with their full threaded length.

### Vertical lifting



**Do not let the lifting slings to touch the electric machine while lifting. Lifting slings may cause damage to the electric machine.**

Vertical lifting

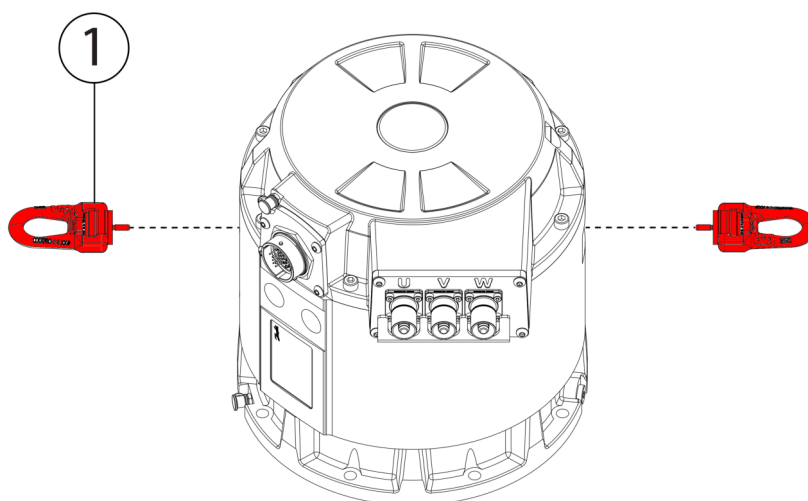

1	Codipro DSR M 8 UP or equivalent of dimensions and load capacity.
---	---

Use swivel type M8 lifting rings with sufficient rated capacity to each loading direction. Refer to the lifting ring manufacturer's instructions when attaching lifting rings to machine. It is important that lifting rings are properly tightened in place.

## Storage



**Do not touch the electrical terminals when the shaft is rotated. The electrical terminals have dangerous voltage during rotation.**



**Keep the electric machine on a correct base. Support the electric machine to prevent accidental turning and falling.**

- Always store the electric machine indoors. Storage temperature must be above -20°C and relative humidity less than 60 %.
- The storage should be dry, dust free and vibration free.
- Treat the unprotected electric machine surfaces such as the shaft-end and flanges against corrosion. Seal the cable exit holes and cooling bores for storage.

## Transportation and storage

- The electric machine must not be subject to any external vibrations during storage to avoid damage to the bearings.
- To avoid water condensing in the electric machine, use anti-condensation heater(s), if fitted, or direct winding heating to keep the machine temperature above dew point.
- Rotate the shaft of the electric machine by hand monthly at least ten revolutions to prevent grease migration. If necessary use a tool such as a spanner. Do not damage the shaft in any case.

### Extended storage

Electric machines equipped with relubricable bearings: apply grease before and after long term storage.





It is recommended to inspect the electric machine in storage at periodic intervals. Use attached storage checklist.

Rotate the shaft of the electric machine once a month.

Keep the electric machine in its installation position while in storage. For example, vertically installed electric machines should be stored in vertical position.

## Installation

The following safety and information related symbols appear in this user guide and on the electric machine.

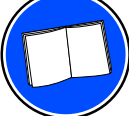
	<p><b>Risk of electric shock when the connection box is open. When you work with power connections make sure that electricity is disconnected and rotor rotation is prevented.</b></p>
	<p><b>Magnetic and electromagnetic fields generated near the current-carrying conductors and permanent magnets in electric machines represent a health danger to persons with heart pacemakers, metal implants and hearing aids. Persons with a heart pacemaker, metal implants or hearing aids must consult a doctor before they enter the following areas:</b></p> <ul style="list-style-type: none"> <li>• Areas in which electric equipment and parts are operated.</li> <li>• Areas in which electric equipment with permanent magnets are stored, mounted, operated or repaired.</li> </ul>
	<p><b>Risk of electric shock when working with the electric machine. Use isolated electric tools.</b></p>
	<p><b>Only trained and qualified personnel familiar with the relevant safety requirements can work with the electric machine.</b></p>
	<p><b>Use correct personal protective equipment when you are near the electric machine.</b></p>
	<p><b>Read the instructions in this user guide before you install the electric machine.</b></p>

## Installation

### Required tools

Following tools are required to install the electric machine:

- Grease pump.
- Ratchet torque wrench.
- Hex head wrench kit with different metric sizes.
- Socket wrench kit with different metric sizes.
- Cable gland tightening tool. Size according to cable glands.
- Cable skinning knife.
- Crimping tool for cable lugs. Consult cable lug manufacturer for correct size and crimping.
- Lifting slings with sufficient rated capacity.
- Lifting eyes. Size according to machine type. See Chapter [Lifting](#) on page 25.

### Insulation resistance test

	<p><b>Before performing the insulation resistance measurement, disconnect all cables and connectors from the electric machine under test.</b></p>
	<p><b>Do not touch the electric machine during the insulation resistance check. Discharge the electric machine afterwards.</b></p>
	<p><b>Measure the insulation resistance of the electric machine before and after the installation of the electric machine.</b></p>

Measure the insulation resistance of the electric machine before and after the installation of the electric machine. Because of the structure of the electric machine, it is possible that the stator is damaged during the installation.

Reference value of 150 MΩ has to be exceeded at reference ambient temperature 25°C (measured with 500 V<sub>DC</sub> / 1 min insulation resistance test). Contact Danfoss Editron service if the reference value is not exceeded.

### Mechanical installation

#### Allowed mounting positions

	<p><b>If the application is a moving work machine or similar, it is allowed to deviate from the allowed mounting position for the duration of 30% of the work cycle. This applies to electric machines with grease lubricated bearings.</b></p>
	<p><b>It is in some cases possible to make an exception from the limitations of the mounting positions. Document <i>Allowed bearing loads for EM-PMI machines DOC-000454</i> gives more information about this. Contact Danfoss to obtain the document.</b></p>

The electric machine can be installed horizontally or vertically. See Figures below for the allowed installation angles in each case.

## Installation

Nominal allowed horizontal mounting position of the electric machine

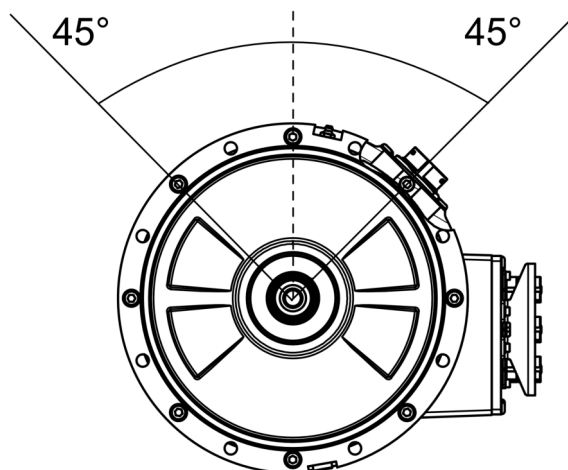

Line type	Meaning
	Allowed deviations from the horizontal mounting limitations, continuous operation. (Depicted from the shaft end.)
	Allowed deviations from the horizontal mounting limitations, for the maximum duration of 30% of the work cycle. (Depicted from the shaft end.)

Allowed deviations from the horizontal mounting limitations

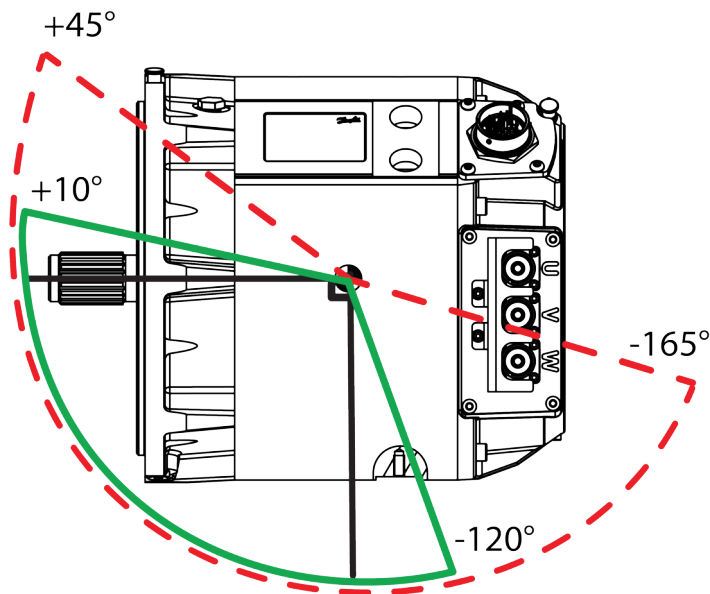

### Mounting the electric machine

	<p>Do not exceed the maximum axial and radial forces calculated for the shaft. Document Allowed bearing loads for EM-PMI machines DOC-000454 gives more information about this. Contact Danfoss to obtain the document.</p>
--	---

## Installation

	<p><b>Do not use the N-end of the electric machine for mounting the electric machine.</b></p>
	<p>Refer to Chapter <a href="#">Allowed mounting positions</a> for the correct mounting positions of the electric machine.</p>

Mount the electric machine on a correct supporting structure as discussed in Chapter [Supporting structure requirements](#).

### Horizontal assembly

1. Lift the electric machine to the correct mounting position. See Chapter [Lifting](#) for details.
2. The electric machine is mounted from its D-end flange (SAE6 transmission housing flange). SAE6 flywheel housing is required as a mating flange.
3. Align the electric machine with the mating housing alignment. See Chapter [Shaft alignment and load](#).
4. Connect the shaft of the electric machine. Make sure to use full spline engagement. Lubricate the spline.

	<p><b>Before connecting to the shaft of the electric machine, clean the protection wax on the shaft splines carefully to avoid potential reaction with the spline lubricant.</b></p>
	<p><b>A recommended spline lubricant is a 50/50 compound of a high temperature grease and a molybdenum disulphide powder. When applied initially and re-applied at proper intervals, it will help prevent fretting corrosion and premature wear. This lubricant is not soluble in oil and should be used accordingly. Further products which may be recommended are Molycote, Metaflux, Never Seeze, Optimol and similar.</b></p>

5. Attach the mounting bolts. For steel housing the minimum length of the bolt is 40 mm and for aluminum housing 45 mm. Refer to Chapter [Tightening torques](#) on page 18 for the correct tightening torques.

*Mechanical mounting connections of the electric machine (horizontal mounting)*

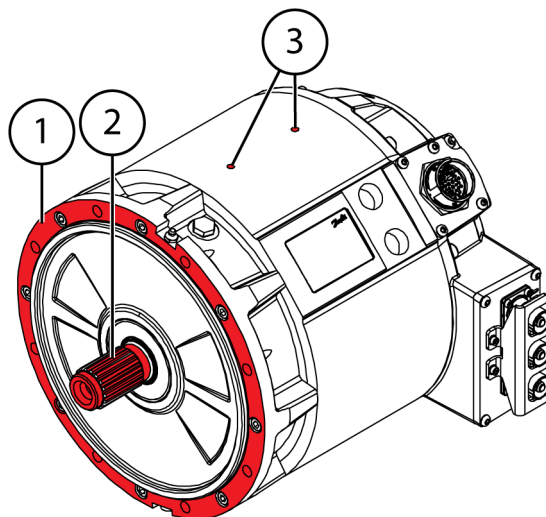



## Installation

1	D-end flange (SAE 6) with mounting holes
2	Shaft connection DIN 5480 Spline W40x2x18x8f
3	Lifting points M8x1.25 (15 mm deep).

### Cooling connections

	<b>Make sure that cooling liquid runs freely into and out from the electric machine.</b>
	<b>To prevent damage to the cooling connectors, refer to the documentation of the manufacturer for the correct tightening torque of the cooling liquid nipples.</b>
	<b>When selecting cooling liquid nipples, choose nipples that can resist galvanic corrosion.</b>

Connect the electric machine properly to the cooling circuit. Make sure that the coolant flow is equal or higher than rated and the coolant temperature at the inlet of the machine cooling is lower or equal to the rated temperature. For more information, see Chapter [Recommended coolants](#) and product data sheet. Rated values can be found in the electric machine rating plate.

Aluminum frame water-cooled construction is only to be used with a closed fresh water circulation with corrosive inhibitor described in the data sheet. The water cooling circuit connection is described in the data sheet. Use only suitable and high-class connection parts and seals to connect the electric machine to the water circuit. Check for possible leaks after the piping and joints have been connected.

It is recommended to use coolant connector equipped with o-ring seal or to use sealing washer (for example Usit or Bonded seals) in the connection. In addition, it is recommended to use thread sealant (Loctite 577 or similar) at the coolant connections to prevent loosening. Loosening can be caused by vibration or temperature variations.

The electric machines are equipped with at least three PT100 temperature sensors in the windings. The amount of the sensors depend on the options chosen. The temperature signal(s) can be read out from the measurement connector of the machine.

## Electrical installation

### Power connections

#### High voltage connection

	<b>Risk of electric shock. When you work with power connections make sure that electricity is disconnected and that the rotation of the rotor is prevented.</b>
--	---

## Installation

	<p><b>Mating connectors of the high voltage cables are not part of a standard delivery.</b></p>
	<p><b>The order of the phases is marked on the power terminal with stickers.</b></p>

### High voltage connection

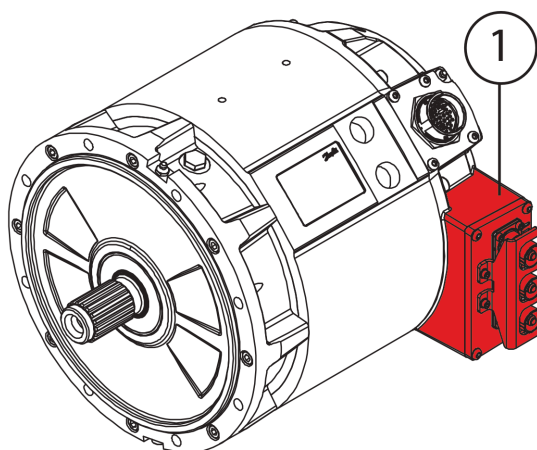

1	<p>Power terminal Connector type: AMPHENOL HVBI005R10AMHARD Mating connector: AMPHENOL HVBI-7-05R10-XFC-XXXX-FG/PC (straight plug)</p>
---	--

### Installing the high voltage cables

1. Remove the connector locking plate. See the Figure below.
2. Install the high voltage cables. Refer to the instructions of the manufacturer of the mating connectors.
3. Install the connector locking plate back.

## Installation

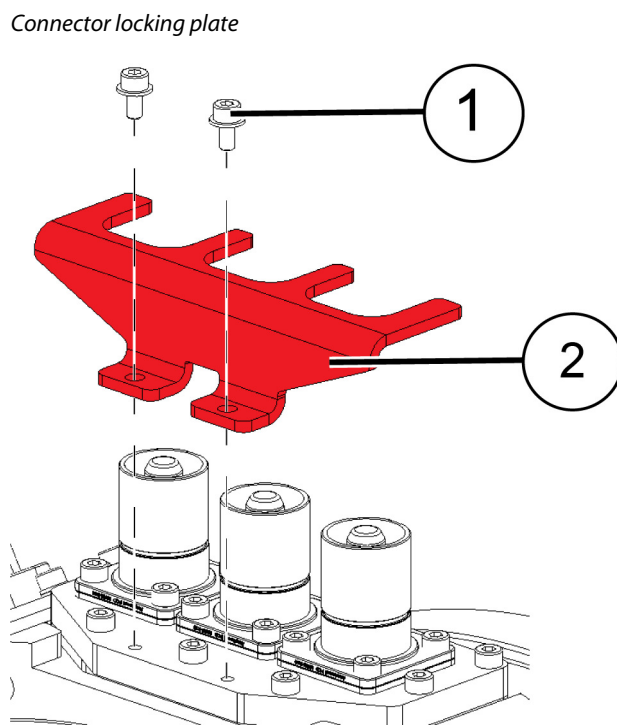

1	Fasteners
2	Connector locking plate

### Connection diagram

The electric machines are intended to be powered and controlled by three-phase alternating current, supplied by an inverter or inverters. The electric machine is not suitable for direct online use.

The amount of inverters depends on the electric machine and converter current ratings. See also the relevant wiring diagrams.

For an electric machine with option SINGLE (one connection box containing one three-phase system), the electrical connection principle from the inverter is shown in the Figure below.

## Installation

Connection diagram for SINGLE option

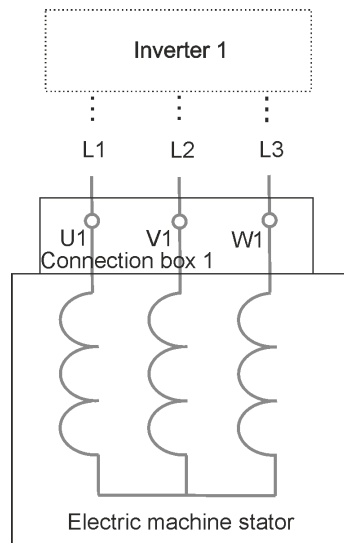

### Low voltage connections



**IP67 level protection is reached only when connector mating part is installed and all unused pin holes are plugged in the connector mating part with the following plugs, depending on the hole size:**

- DEUTSCH 0413-003-1605 (size 16)
- DEUTSCH 0413-204-2005 (size 20)

**For further information, contact the connector manufacturer TE connectivity directly.**

The electric machine has a connector or a connection box which is used to read out in-built temperature and rotation sensor (resolver) data from the electric machine. The temperature data comes from PT100 sensors in the stator windings and in some cases in the bearings. The rating plate has the information about the options of the electric machine: different options add sensors, and some electric machines do not have all the sensors. For more information about the options, refer to Chapter [Product naming convention](#) on page 5.

See more information and instructions about DEUTSCH connectors at <https://www.deutschconnector.com/>.

### Recommended cable types for low voltage connections

Application	Cable type
Resolver cabling	Shielded cable (twisted pair)
Temperature measurement (PT100)	Shielded cable (twisted pair)

## Installation

Low voltage connector (1), Deutsch HD34-24-47PE

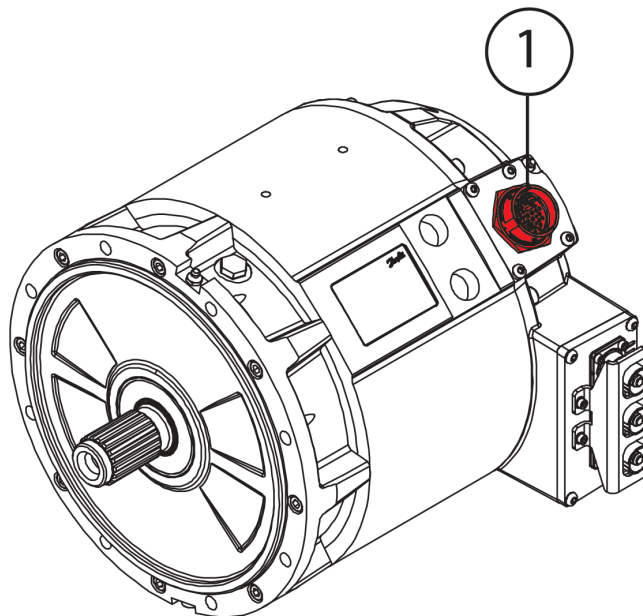

1	Low voltage connector
---	-----------------------

### Low voltage connector details

	<p><b>Deutsch HD34-24-47PE connector has two kinds of mating pins: 1 mm and 1.5 mm in diameter.</b></p>
--	---

Pin configuration of the Deutsch HD34-24-47PE connector

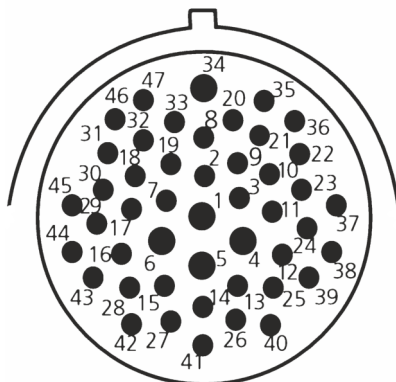

Pin configuration of the Deutsch HD34-24-47PE connector

Measurement	Description	PIN
Temperature 1	Temperature 1, PT100 (P), windings	47
	Temperature 1, PT100 (N), windings	46

## Installation

Pin configuration of the Deutsch HD34-24-47PE connector (continued)

Measurement	Description	PIN
Temperature 2	Temperature 2, PT100 (P), windings	33
	Temperature 2, PT100 (N), windings	32
Temperature 3	Temperature 3, PT100 (P), windings	45
	Temperature 3, PT100 (N), windings	31
Temperature 4	Temperature 4, PT100 (P), windings, option TEMP4	30
	Temperature 4, PT100 (N), windings, option TEMP4	29
Temperature 5	Temperature 5, PT100 (P), windings, option TEMP4	44
	Temperature 5, PT100 (N), windings, option TEMP4	43
Temperature 6	Temperature 6, PT100 (P), windings, option TEMP4	28
	Temperature 6, PT100 (N), windings, option TEMP4	16
Resolver COS_N	Resolver, RES_COS_N, inbuilt non-contacting	35
Resolver COS_P	Resolver, RES_COS_P, inbuilt non-contacting	20
Resolver SIN_N	Resolver, RES_SIN_N, inbuilt non-contacting	36
Resolver SIN_P	Resolver, RES_SIN_P, inbuilt non-contacting	21
Resolver EXCN	Resolver, EXCN, inbuilt non-contacting	22
Resolver EXCP	Resolver, EXCP, inbuilt non-contacting	10
Resolver shield	Resolver, SHIELD/GROUND, inbuilt non-contacting	34

### Grounding connections

	<b>Ground the electric machine from its frame to make sure it functions correctly and safely.</b>
	<b>Ground the cable shields of the power cables to make sure the electric machine functions correctly and safely.</b>
	<b>Ground the cable shields of the instrumentation cables to make sure the electric machine functions correctly and safely.</b>
	<b>It is recommended to perform a ground bond test after installing the electric machine to make sure the electric machine is correctly grounded.</b>
	<b>The grounding points on the frame of the electric machine are for safety grounding, and signal cables and power cable shields have their own grounding points.</b>

## Installation

*The machine enclosure grounding point, safety grounding*

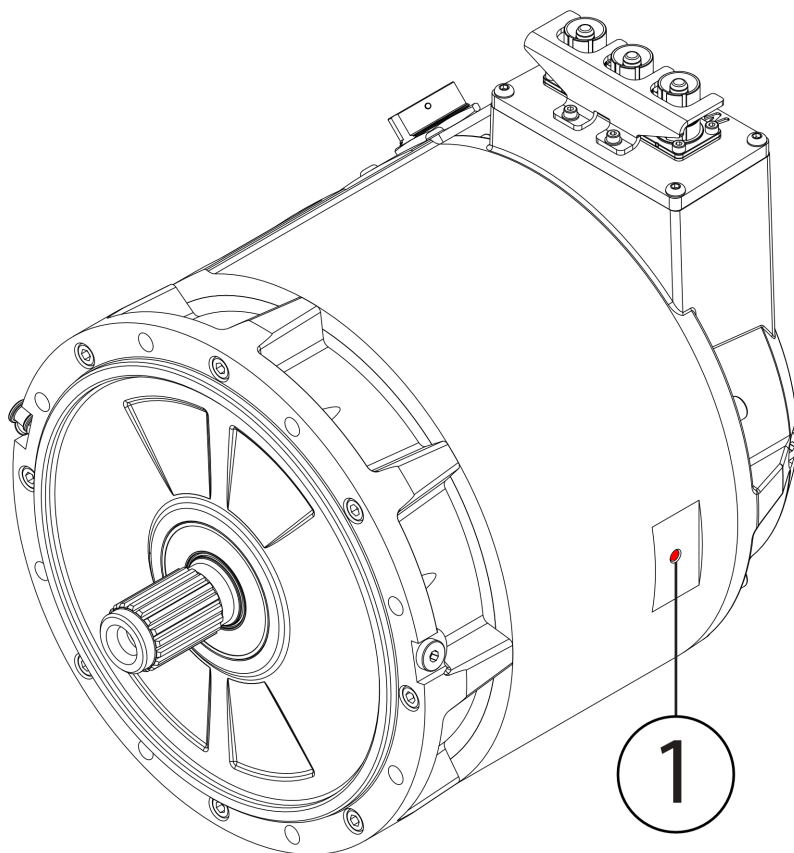

1	Grounding point
---	-----------------

*Low voltage cable grounding points*

### **Testing the power cable shield grounding (earthing)**

1. Connect one terminal of the measurement device to the cable shield of one power cable (in the inverter end of the cable)
2. Connect the other terminal of the measurement device to the cable shield of another power cable. You can also use the machine enclosure grounding point for the measurement.
3. Measure the resistance between the two cable shields or between the cable shield and the enclosure grounding point.
4. Change the measurement device terminal(s) to the shield of different power cable and repeat the measurement until all cables have been measured.

### **Testing the low voltage (measurement signal) cable shield grounding (earthing)**

1. Connect one terminal of the measurement device to the low voltage cable shield (in the non-machine end of the cable).
2. Connect the other terminal of the measurement device to the machine enclosure grounding point.
3. Measure the resistance between the cable shield and the enclosure grounding point.

Operation

	<p>Only trained and qualified personnel familiar with the relevant safety requirements are allowed to operate the electric machine.</p>
	<p>Do not use the electric machine without properly dimensioned and operating cooling system. Maximum operation temperature, current and rotational speed of the electric machine must not be exceeded to avoid permanent damage.</p>
	<p>The surface of the electric machine might be hot. Do not touch the electric machine during operation.</p>
	<p>Entanglement hazard! Do not touch the electric machine during operation.</p>
	<p>Use sufficient personal protective equipment when you are near the electric machine.</p>
	<p>Read the instructions in this user guide before you install the electric machine.</p>

Operation conditions

The electric machine should be used for its intended purpose only and within limits specified by the manufacturer, concerning:



## Operation

- Loading.
- Cooling.
- Speed range.
- Service interval.
- Ambient condition such as temperature and moisture.

The electric machine is designed for the following conditions:

- Ambient temperature limits: -40°C...+65°C.
- Maximum altitude 1000 m above sea level.
- Coolant liquid must be water-glycol mixture with maximum of 50 % glycol content. See Chapter [Recommended coolants](#).
- For the maximum coolant liquid temperature at the inlet of the coolant circuit, see the product data sheet.

If electric machine operation limits are exceeded, please contact Danfoss representative.

### Condition monitoring during operation

	<b>Supervise the electric machine during operation to make sure that the electric machine operates correctly and has a designed lifetime.</b>
	<b>If you notice any deviations from the normal operation, for example elevated temperatures, noise or vibration, stop the electric machine. Find the reason for the deviation and repair the electric machine. Refer to Chapter <a href="#">Troubleshooting</a> on page 50.</b>
	<b>Electrical safety of the system and the end application has to be guaranteed using appropriate methods, like external insulation resistance or residual current monitoring, depending on the application.</b>
	<b>The maximum allowed winding temperature of the electric machine is shown on the rating plate and in the data sheet.</b>

### Recommended lubricants





	<b>Do not mix different types of lubricants!</b>
--	--

Greased for life bearings do not need relubrication during their lifetime. Grease relubricable bearings (BHS option) need regular greasing. For further information, see Chapter [Bearings and lubrication](#) on page 46.

The recommended grease type for the machine bearings is SKF LGHP-2 or equivalent. LGHP-2 is high performance, high temperature bearing grease. For further information, see <http://www.skf.com/>.

## Operation

### Recommended coolants

	<p><b>Ethylene glycol is a toxic compound. Avoid exposure to the coolant.</b></p>
	<p><b>Copper ions concentration of more than approx. 0.06 ppm causes <i>copper induced pitting corrosion</i>. Do not use copper components in the cooling system.</b></p>
	<p><b>Hard piping made of metal is recommended for the coolant instead of soft piping as rubber hoses.</b></p>
	<p><b>Use correct personal protective equipment when you handle the coolant.</b></p>

The electric machines are designed to work properly with water based coolant. Plain water with appropriate corrosive inhibitor is acceptable, for example 50 % water- 50 % glycol coolant.

Glycol coolant options:

- Ethylene glycol based Glysantin® G48® (includes also corrosion inhibitors).
- Propylene glycol based coolants, like Splash® RV&Marine antifreeze.

### Emergency operation

The electric machine should be operated within the operation limits and in the conditions specified by the manufacturer. However, it can be used with some limitations in the following fault/emergency situations.

#### Cooling of the electric machine fails

Cooling system failure can be caused by dregs (sediment) accumulating in the cooling system tubes. Try opening the possible blockage by changing the coolant flow direction. See also Chapter [Cooling system maintenance](#).

If the cooling of the electric machine fails, limited operation is still possible with no coolant flow. The operation speed must be limited to half (1/2) of the rated speed and maximum 20 % of the nominal torque may be used. In such case, the electric machine may be operated for maximum one hour. Repair the cooling system as soon as possible. For further information, contact Danfoss representative.

#### The temperature measurement of the electric machine fails

The operation temperature of the electric machine is measured by PT100 temperature sensors in the electric machine windings. The temperature signals can be read out from the measurement connector of the electric machine, and connect to the temperature surveillance pin in the inverter for example. In case of a temperature measurement sensor failure in the electric machine, an additional PT100 sensor can be mounted close to the end of the windings at the low voltage (measurement signal) connector opening.

## Operation

1. Remove the low voltage (measurement signal) connector from the electric machine enclosure. Be careful not to damage the cables and joints.
2. Mount (glue) an additional PT100 temperature sensor close to the end of the windings at the opening. Use resin/glue specified for correct temperatures (Temp.class in the rating plate, class F / 155 °C).
3. Connect the PT100 sensor to the low voltage connector (replace the failed sensor connection by the new connection).
4. Remount the low voltage connector to its place.

When reading the temperature (resistance) values from the additional sensor, add +15°C to the measured value. This gives more correct estimation of the inner temperature of the electric machine. In case of the temperature measurement failure and using additional temperature sensor, replace the electric machine as soon as possible, but no later than in two months.

### **Danfoss service contact information**

Contact Danfoss service at <https://danfosseditron.zendesk.com/hc/en-gb> or send email to [editron.service@danfoss.com](mailto:editron.service@danfoss.com).

## Maintenance

This Chapter contains necessary information for the qualified and trained personnel to carry out regular maintenance work.

	<p><b>Do not disassemble the electric machine. Only procedures described in this user guide may be done.</b></p>
	<p><b>Only trained and qualified personnel familiar with the relevant safety requirements are allowed to do maintenance to the electric machine.</b></p>
	<p><b>Risk of electric shock when the connection box is open.</b></p>
	<p><b>Use correct personal protective equipment when you are near the electric machine.</b></p>
	<p><b>Read the instructions in the user guide before you start to work with the electric machine. To make sure that the operation of the electric machine is safe and reliable, obey the maintenance instructions.</b></p>

## Regular maintenance

	<p><b>Inspect the electric machine at regular intervals.</b></p>
--	--

## Maintenance



**Do not attempt to tighten bolts or screws that are not discussed in this user guide and that are not needed for normal installation and maintenance procedures. The sealing of the bolts and screws can break.**

Correct supervision and maintenance of the electric machine makes sure that the electric machine has reliable operation and designed lifetime.

### Maintenance schedule

Object		Check/Task	Weekly	Monthly	Yearly
General construction	Operation	Noise, vibration. If clearly increased, contact Danfoss.	X		
	Mounting	Bolt tightness. Tighten to proper value if necessary. Applies to bolts and screws that are discussed in this user guide. See Chapter <a href="#">Tightening torques</a> .			X
	Bearings	Listen to any unusual noise or vibration. If exists, contact Danfoss.			X
	Enclosure and connected parts	Check cleanliness. Clean if necessary. See Chapter <a href="#">Cleaning</a>		X	
Electrical system	Cables	Wearing of the cables. Replace if necessary.		X	
	Electrical connections	Check connections. Make sure that tightening torque is correct for the cable glands. See Chapter <a href="#">Tightening torques</a> .			X
	Groundings (earthings)	Check groundings (earthings). Make sure that the connection resistance is correct. Re-connect if necessary.			X
Cooling system	Operation	Functioning. Cooling system functions as specified.	X		
	Tubing and connection tightness	No visible leakage. If leaking, tighten connections appropriately, or replace parts.		X	
	Ventilation plug	Cleanliness. Clean if necessary. See chapter <a href="#">Cleaning</a> .		X	
	Coolant flow	Coolant flow direction. Change direction by changing the connections or flow direction from the pump. See Chapter <a href="#">Cooling system maintenance</a> .			X
	Coolant quality	Coolant as specified. Proper glycol used, and water/glycol mixture correct. Refill if necessary. See Chapter <a href="#">Cooling system maintenance</a> .			X
Lubrication	Relubrication (BHS option)	Relubricate depending on the use (see Chapter <a href="#">Bearings and lubrication</a> ), if the option has been installed. Maximum relubrication interval is six months.		X	

## Cleaning



**Never open or remove the watertight ventilation plugs. Clean them only from the outside.**



**Risk of electric shock if the electric machine is cleaned against instructions allowing water to go in to the electric machine.**

Keep the electric machine clean. For cleaning, use non-abrasive and non-corrosive cleaning products.

Make sure that the detergent may be used for aluminum.

When pressure washing the electric machine, make sure that the water spray does not directly hit the gaskets.

## Maintenance

Ventilation plugs

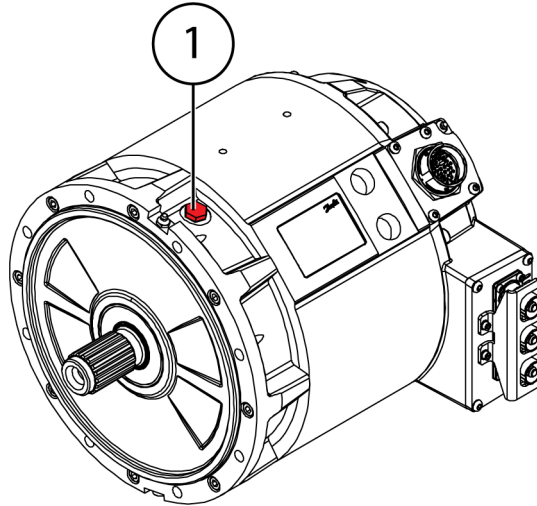

1	Ventilation plug (do not remove)
---	----------------------------------

## Bearings and lubrication

### Grease relubricable bearings

	<b>The grease relubricable bearings need regular greasing. Follow the relubrication interval and instructions described in this Chapter.</b>
	<b>Lubricants can cause skin irritation and eye inflammation. Follow all safety precautions specified by the manufacturer of the lubricant.</b>
	<b>Make sure that the automatic greasing and the oil lubrication function correctly after you start the electric machine.</b>
	<b>The bearing type of the electric machine can be found on the rating plate of the electric machine.</b>
	<b>It is recommended to have a piping for the grease exiting the electric machine. The grease exit hole is often in an inconvenient location when the electric machine is installed.</b>

The bearing type for electric machine is 6009/C3. See the recommended lubricant in Chapter [Recommended lubricants](#) on page 41.

## Maintenance

### Bearing relubrication

	<p><b>Beware of rotating parts. Do not touch the electric machine during operation.</b></p>
	<p><b>The surface of the electric machine can be hot. Use correct protective equipment (heat resistant gloves) when you handle the electric machine.</b></p>
	<p><b>The information of bearing lifetime and bearing grease lifetime are estimations only to provide a magnitude of them. The bearing lifetime and bearing grease lifetime in customer application may vary. Danfoss is not responsible for the actual bearing lifetime in use. For further information, contact Danfoss representative.</b></p>
	<p><b>The maximum relubrication interval in operation is six months. The amount of grease per relubrication is 6 g.</b></p>

The relubrication interval depends on the used rotation speed and bearing temperature, and is presented in the Figure below. The different curves represent different bearing temperatures. The higher the temperature is and the higher the rotation speed is, the lower the relubrication interval is.

*Relubrication interval of the machine compared to rotation speed and bearing temperature*

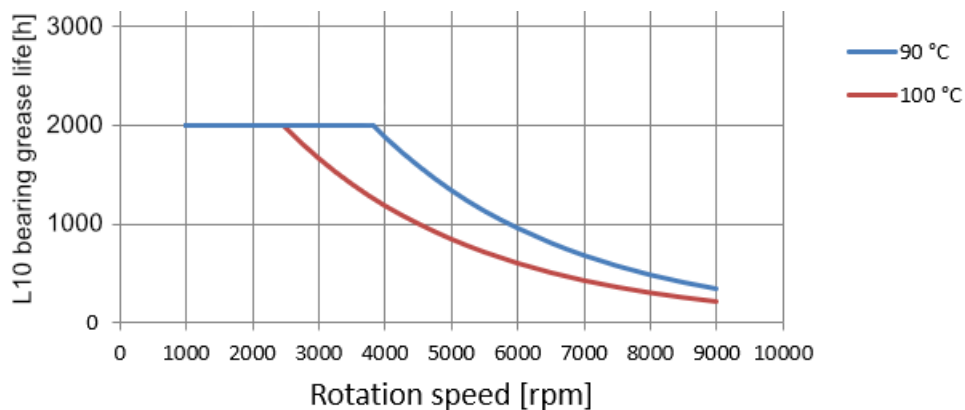

## Maintenance

Relubrication interval of the machine compared to rotation speed and bearing temperature, vertical installation

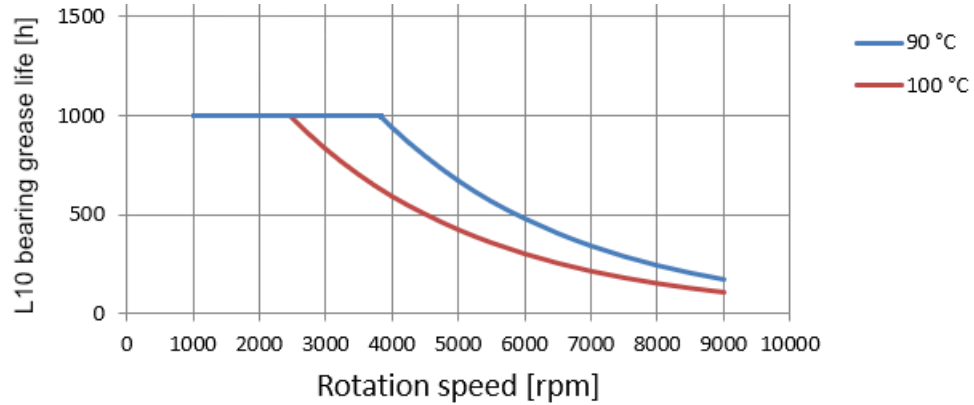

For more information about the location of grease nipples and grease escape holes, see Chapter [Connections and interfaces](#) on page 15.

Bearing relubrication:



It is normal if no grease exits the electric machine. This is because the cavities inside the electric machine can hold a lot of grease.

1. Make sure that the electric machine has reached its operating temperature.
2. Remove the plugs from the grease escape hole(s).
3. Open the grease nipple plug(s).
4. Use grease piston to enter specific amount of grease into the grease nipple.
5. If possible, let the electric machine run approximately one hour to let the old grease exit.
6. Install the plug(s) on the grease nipple(s) and on the grease escape hole(s).

## Cooling system maintenance

It is recommended to change the direction of the coolant liquid flow yearly. This is done by changing the order of the coolant connections, or changing the coolant pump direction. The reason for changing the coolant flow direction is to prevent possible dregs (sediment) accumulating to the cooling system.

The quality of the coolant must be checked yearly. The mixture of coolant fluid must be according to specification. See Chapter [Recommended coolants](#).



## Dismounting

	<b>Make sure that the mating structure is not damaged. Do not pluck any bores or use at headed bolts or rods for pushing the electric machine out of the mating structure.</b>
---	--

For dismounting the electric machine, follow the Steps below.

1. Prepare the electric machine for lifting, for more information refer to Chapter [Lifting](#) on page 25. Support the electric machine with lifting slings when dismounting.
2. Loosen the mounting bolts. For more information refer to Chapter [Mounting the electric machine](#) on page 31.
3. If force is required, use the bores in D-end flange to push the electric machine out from the mating structure, or use some other method that does not damage the electric machine.
4. Lift the electric machine off. Support the electric machine when lifting.

## Troubleshooting

Some difficulties may occur while operating the electric machine. Possible causes and actions are given in the Table below. If the situation occurs, it should be corrected as soon as possible. These instructions do not cover all details or variations in the equipment nor provide information for every possible condition to be met in connection with installation, operation or maintenance.

For more information, contact Danfoss service at <https://danfossedatron.zendesk.com/hc/en-gb> or send email to [editron.service@danfoss.com](mailto:editron.service@danfoss.com).

### Troubleshooting chart

Symptom	Possible cause	Action
Excessive vibration, noise	Imbalance at the connected electric machine or the powertrain components.	Check the balance and installation of the drivetrain components.
	Misalignment between the electric machine and the used device.	Check the shaft connections and couplings. Ensure that the alignment is within the specifications listed in Chapter <i>Shaft alignment and load</i> on page 22.
	Attachment bolts are loose.	Replace and tighten the bolts.
	Clearance at the spline connection.	Check the spline connection.
	Imbalance at the electric machine.	Contact local Danfoss representative.
	Particles inside the electric machine.	
	Bearing damage.	
	Inadequate lubrication (grease lubricated bearings).	Apply bearing lubricant/grease. See Chapter <i>Bearings and lubrication</i> . Contact local Danfoss representative for further information.
Bearing temperature rise	Inadequate lubrication (grease lubricated bearings).	Apply bearing lubricant/grease. See Chapter <i>Bearings and lubrication</i> .
	Too much grease in the bearing housing (grease lubricated bearings).	Open grease escape valve and let the electric machine run for 10 min. Clean the grease escape channel from solidified grease using brush if necessary.
	Incorrect bearing grease.	Check that the used grease is of correct type.
	Overloaded bearing.	Check that the system is not causing excess force or vibration to the machine bearings. Check the alignment of the machine shaft, see Chapter <i>Shaft alignment and load</i> on page 22.
	Bearing damage.	Contact local Danfoss representative for further information.
	Incorrect mounting option	Check motor mounting orientation and confirm that the motor has the correct option (vertical or horizontal mounting).
Electric machine overheating	Overload.	Reduce load. Check the machine rating plate and ensure that inverter limits are set accordingly.
	Cooling system failure.	Check the cooling system integrity, flow and fluid temperature. Change the cooling flow direction to flush the cooling system from sediment that has possibly accumulated. See also Chapter <i>Emergency operation</i> .
	Leakage in the cooling system.	Check the cooling system circuit and tighten the leaking connections.
	Rigid particle inside the machine cooling channel.	Try pulsating coolant to open the channels. Contact local Danfoss representative.
	Wrong machine parameters in the inverter.	Check and correct the machine parameters in the inverter.
	Damaged winding.	Measure the insulation resistance. Measure the winding resistance with a high-precision DC resistance meter and compare to manufacturer specifications. Replace the electric machine if necessary.
	Inverter switching frequency too low.	If other than a Danfoss Editron inverter is used, ensure that the switching frequency is at least equal to the required minimum switching frequency of the motor. See corresponding product data sheet.

## Troubleshooting

### Troubleshooting chart (continued)

Symptom	Possible cause	Action
Connection box and / or motor cables overheating	Cable lug bolts loose.	Check torque of cable lug bolts. See also Chapter <a href="#">Power connections</a> on page 33.
	Cable diameter too small.	Replace power cables with appropriate cable type.
	Cable lug crimps insufficient or incorrect.	Replace cable lugs. Use recommended cable lugs and crimping tools.
	Contamination or insulating substance between cable lug and bus bar.	Check that the contact surfaces of the bus bars and cable lugs are clean and undamaged. Ensure there is no grease, thread locking compound, dirt or other foreign substances between the bus bar and cable lug.
Significant lubricant leak	Worn radial lip seal.	Contact local Danfoss representative.
	Block at the grease outlet channel.	Clean the grease escape channel from solidified grease using brush if necessary.
Electric machine does not work properly or the performance is poor	Wrong electric machine parameters in the inverter.	Check and correct the electric machine parameters from the inverter. See inverter user manual and other relevant documentation.
	Demagnetization of magnets due to overheating.	Check that the back-EMF of the motor is within specifications. Contact local Danfoss representative. Replace the electric machine if necessary.
	Bearing fault.	Check the bearing temperature, lubrication and conditions. Contact local Danfoss representative for further information.
	Insulation or winding fault.	Measure the insulation resistance, refer to the manufacturer limits. See Chapter <a href="#">Insulation resistance test</a> . Measure the winding resistance with a high-precision DC resistance meter and compare to manufacturer specifications. Replace the electric machine if necessary.
Moisture and / or corrosion inside the connection box or motor	Cable glands installed incorrectly.	Check tightening torque and sealing of the cable glands.
	Power cables installed incorrectly.	Check cable installation and sealing with cable glands.
	Connection box cover bolts are too loose, too tight, or cover seal is damaged.	Check the integrity of the seal on the connection box cover. Tighten the cover bolts to the specified torque.
	Low voltage connector damaged or not connected.	Contact local Danfoss representative.
	Breather cap blocked.	Check that the breather cap of the electric machine is not submerged in liquid, painted, or covered by any object
Temperature measurement failure	The PT100 sensor is faulty.	Measure the resistance of the PT100 sensor, see Chapter <a href="#">Low voltage connections</a> . If the sensor is faulty, read out the signal from another sensor. Contact local Danfoss representative. See also Chapter <a href="#">Emergency operation</a> .
Resolver sensor failure	Resolver wiring is faulty.	Check the wiring of the resolver and make sure that a shielded and twisted pair cable is used with the correct pairing of the signals.
	Resolver sensor is damaged.	Contact local Danfoss representative.

## Aftersales

### Service policy

Maintenance and service of the electric machine is limited to the procedures described in this user guide.

If the electric machine has service parts available, you can find them in Chapter [Service parts](#).

For further information, go to <https://danfosseditron.zendesk.com/hc/en-gb> or send email to [editron.service@danfoss.com](mailto:editron.service@danfoss.com).

## **Disposal**

Dispose of the electric machine and any of its parts by appropriate means in accordance with local laws and regulations.

## Storage, installation and maintenance checklists

### Electric machine installation checklist

Date:

#### Electric machine and customer information

<b>Customer:</b>	<b>Electric machine type (from the rating plate):</b>
<b>Customer reference:</b>	<b>Electric machine serial number:</b>
<b>Service reference:</b>	<b>Date installed:</b>

N.A = Procedure not applicable PASS = Procedure passed FAIL = Procedure failed

#### Installation checklist

	Approval	N.A	PASS	FAIL
<b>General</b>				
Electric machine type is correct		<input type="checkbox"/>	<input type="checkbox"/>	<input type="checkbox"/>
Electric machine is undamaged		<input type="checkbox"/>	<input type="checkbox"/>	<input type="checkbox"/>
Insulation resistance check For more information, see <a href="#">Insulation resistance test</a> on page 30.	Reference value of 150 MΩ must be exceeded at reference ambient temperature 25°C (measured with 500 V <sub>DC</sub> / 1 min insulation resistance test).	<input type="checkbox"/>	<input type="checkbox"/>	<input type="checkbox"/>
Environmental conditions as specified (see data sheet)		<input type="checkbox"/>	<input type="checkbox"/>	<input type="checkbox"/>
<b>Mechanical installation</b>				
Supporting structure as required		<input type="checkbox"/>	<input type="checkbox"/>	<input type="checkbox"/>
Shaft alignment as specified (see chapter Shaft alignment and load).		<input type="checkbox"/>	<input type="checkbox"/>	<input type="checkbox"/>
Cooling circuit connected and coolant flowing		<input type="checkbox"/>	<input type="checkbox"/>	<input type="checkbox"/>
<b>Used coolant:</b>				
<b>Power connections</b>				
Cable connector assembly as specified with correct cable diameter		<input type="checkbox"/>	<input type="checkbox"/>	<input type="checkbox"/>
The phase connections order is correct (U, V, W -> L1, L2, L3)		<input type="checkbox"/>	<input type="checkbox"/>	<input type="checkbox"/>
<b>Grounding</b>				
Electric machine enclosure grounding connected		<input type="checkbox"/>	<input type="checkbox"/>	<input type="checkbox"/>
Low voltage cable shield grounding connected		<input type="checkbox"/>	<input type="checkbox"/>	<input type="checkbox"/>
Power cable shield connection resistances to ground (electric machine enclosure) measured and valid		<input type="checkbox"/>	<input type="checkbox"/>	<input type="checkbox"/>

## Storage, installation and maintenance checklists

### Installation checklist (continued)

	Approval	N.A	PASS	FAIL
Low voltage cable shield grounding resistances measured and valid		<input type="checkbox"/>	<input type="checkbox"/>	<input type="checkbox"/>
<b>Notes:</b> <ul style="list-style-type: none"> <li>•</li> <li>•</li> <li>•</li> <li>•</li> <li>•</li> <li>•</li> <li>•</li> <li>•</li> <li>•</li> <li>•</li> <li>•</li> <li>•</li> <li>•</li> <li>•</li> </ul> <b>Date:</b> <b>Signature:</b>				

Do not try to tighten bolts or screws that are not discussed in the product manual and that are not needed for the normal installation procedures. Sealing of the screws may break.

### Electric machine weekly maintenance checklist

**Date:**

### Electric machine and customer information

<b>Customer:</b>	<b>Electric machine type (from the rating plate):</b>
<b>Customer reference:</b>	<b>Electric machine serial number:</b>
<b>Service reference:</b>	<b>Date installed:</b>

N.A = Procedure not applicable PASS = Procedure passed FAIL = Procedure failed

### Electric machine weekly maintenance checklist

	N.A	PASS	FAIL
<b>General construction</b>			
Noise or vibration during operation in general	<input type="checkbox"/>	<input type="checkbox"/>	<input type="checkbox"/>
<b>Cooling system</b>			

## Storage, installation and maintenance checklists

### Electric machine weekly maintenance checklist (continued)

	N.A	PASS	FAIL
Functioning of the cooling system in general	<input type="checkbox"/>	<input type="checkbox"/>	<input type="checkbox"/>
<b>Notes:</b> <ul style="list-style-type: none"> <li>•</li> <li>•</li> <li>•</li> <li>•</li> <li>•</li> <li>•</li> <li>•</li> <li>•</li> <li>•</li> <li>•</li> <li>•</li> <li>•</li> </ul>			

### Electric machine monthly maintenance checklist

Date:

#### Electric machine and customer information

<b>Customer:</b>	<b>Electric machine type (from the rating plate):</b>
<b>Customer reference:</b>	<b>Electric machine serial number:</b>
<b>Service reference:</b>	<b>Date installed:</b>

N.A = Procedure not applicable PASS = Procedure passed FAIL = Procedure failed

### Electric machine monthly maintenance checklist

	N.A	PASS	FAIL
<b>General construction</b>			
Noise or vibration during operation in general	<input type="checkbox"/>	<input type="checkbox"/>	<input type="checkbox"/>
Cleanliness of the enclosure and connected parts	<input type="checkbox"/>	<input type="checkbox"/>	<input type="checkbox"/>
<b>Electrical system</b>			
Weariness of the cables	<input type="checkbox"/>	<input type="checkbox"/>	<input type="checkbox"/>
Electrical connections in general	<input type="checkbox"/>	<input type="checkbox"/>	<input type="checkbox"/>
Insulation monitoring	Continuous insulation monitoring. (It is recommended to use continuous insulation monitoring for the whole system where electric machine is used.)		
<b>Cooling system</b>			
Functioning of the cooling system in general	<input type="checkbox"/>	<input type="checkbox"/>	<input type="checkbox"/>
Tightness of the ventilation plug	<input type="checkbox"/>	<input type="checkbox"/>	<input type="checkbox"/>



## Storage, installation and maintenance checklists

### Electric machine monthly maintenance checklist (continued)

	N.A	PASS	FAIL
Cleanliness of the ventilation plug	<input type="checkbox"/>	<input type="checkbox"/>	<input type="checkbox"/>
<b>Notes:</b> <ul style="list-style-type: none"> <li>•</li> <li>•</li> <li>•</li> <li>•</li> <li>•</li> <li>•</li> <li>•</li> <li>•</li> <li>•</li> <li>•</li> <li>•</li> <li>•</li> <li>•</li> <li>•</li> <li>•</li> </ul>			

### Electric machine yearly maintenance checklist

Date:

#### Electric machine and customer information

<b>Customer:</b>	<b>Electric machine type (from the rating plate):</b>
<b>Customer reference:</b>	<b>Electric machine serial number:</b>
<b>Service reference:</b>	<b>Date installed:</b>

N.A = Procedure not applicable PASS = Procedure passed FAIL = Procedure failed

### Electric machine yearly maintenance checklist

	Acceptance	N.A	PASS	FAIL
<b>General construction</b>				
Noise or vibration during operation in general	<input type="checkbox"/>	<input type="checkbox"/>	<input type="checkbox"/>	<input type="checkbox"/>
Cleanliness of the enclosure and connected parts	<input type="checkbox"/>	<input type="checkbox"/>	<input type="checkbox"/>	<input type="checkbox"/>
<b>Electrical system</b>				
Weariness of the cables	<input type="checkbox"/>	<input type="checkbox"/>	<input type="checkbox"/>	<input type="checkbox"/>
Electrical connections in general	<input type="checkbox"/>	<input type="checkbox"/>	<input type="checkbox"/>	<input type="checkbox"/>
<b>Cooling system</b>				
Coolant flow direction changed and connection checked	<input type="checkbox"/>	<input type="checkbox"/>	<input type="checkbox"/>	<input type="checkbox"/>
Coolant quality as specified	<input type="checkbox"/>	<input type="checkbox"/>	<input type="checkbox"/>	<input type="checkbox"/>
Used coolant:				
Functioning of the cooling system in general	<input type="checkbox"/>	<input type="checkbox"/>	<input type="checkbox"/>	<input type="checkbox"/>
Tightness of the tubing and connections (no leakages)	<input type="checkbox"/>	<input type="checkbox"/>	<input type="checkbox"/>	<input type="checkbox"/>
Cleanliness of the ventilation plug	<input type="checkbox"/>	<input type="checkbox"/>	<input type="checkbox"/>	<input type="checkbox"/>
<b>Grounding</b>				
Power cable shield connection resistances to ground (electric machine enclosure) checked	<input type="checkbox"/>	<input type="checkbox"/>	<input type="checkbox"/>	<input type="checkbox"/>

## Storage, installation and maintenance checklists

### Electric machine yearly maintenance checklist (continued)

	Acceptance	N.A	PASS	FAIL
Low voltage cable shield grounding resistances checked	<input type="checkbox"/>	<input type="checkbox"/>	<input type="checkbox"/>	<input type="checkbox"/>
Notes:				
<ul style="list-style-type: none"> <li>•</li> <li>•</li> <li>•</li> <li>•</li> <li>•</li> <li>•</li> <li>•</li> <li>•</li> <li>•</li> <li>•</li> <li>•</li> <li>•</li> <li>•</li> <li>•</li> </ul>				

Do not try to tighten bolts or screws that are not discussed in the product manual and that are not needed for the normal installation procedures. Sealing of the screws may break.

For cleaning instructions, refer to Chapter [Cleaning](#) on page 45.

### Used service parts

Part description	Part type	Quantity	Item (order) number
–			
–			
–			
–			
–			
Notes:			
<ul style="list-style-type: none"> <li>•</li> <li>•</li> <li>•</li> <li>•</li> <li>•</li> <li>•</li> <li>•</li> <li>•</li> <li>•</li> <li>•</li> <li>•</li> <li>•</li> <li>•</li> <li>•</li> </ul>			
Date:			
Signature:			

### Electric machine storage checklist

Date:

### Electric machine and customer information

<b>Customer:</b>	<b>Electric machine type (from the rating plate):</b>
<b>Customer reference:</b>	<b>Electric machine serial number:</b>
<b>Service reference:</b>	<b>Date installed:</b>

### Storage, installation and maintenance checklists

This storage checklist is used when storing the electric machine. Regular inspection is required. See specifications for storage in this User Guide or in the Data Sheet.

Fill in the date of each inspection to the Table below.

#### Storage checklist

Procedure	Date	Date	Date	Date	Date
Storage base as specified (vibration free)					
Storage temperature and humidity as specified					
Electric machine type and serial number is correct					
Electric machine supported correctly					
Insulation resistance (test insulation resistance every three months in storage)					
Shaft rotated as specified (10 rotations monthly)					

### Products we offer:

- Cartridge valves
- DCV directional control valves
- Electric converters
- Electric machines
- Electric motors
- Gear motors
- Gear pumps
- Hydraulic integrated circuits (HICs)
- Hydrostatic motors
- Hydrostatic pumps
- Orbital motors
- PLUS+1® controllers
- PLUS+1® displays
- PLUS+1® joysticks and pedals
- PLUS+1® operator interfaces
- PLUS+1® sensors
- PLUS+1® software
- PLUS+1® software services, support and training
- Position controls and sensors
- PVG proportional valves
- Steering components and systems
- Telematics

**Danfoss Power Solutions** is a global manufacturer and supplier of high-quality hydraulic and electric components. We specialize in providing state-of-the-art technology and solutions that excel in the harsh operating conditions of the mobile off-highway market as well as the marine sector. Building on our extensive applications expertise, we work closely with you to ensure exceptional performance for a broad range of applications. We help you and other customers around the world speed up system development, reduce costs and bring vehicles and vessels to market faster.

Danfoss Power Solutions – your strongest partner in mobile hydraulics and mobile electrification.

### Go to [www.danfoss.com](http://www.danfoss.com) for further product information.

We offer you expert worldwide support for ensuring the best possible solutions for outstanding performance. And with an extensive network of Global Service Partners, we also provide you with comprehensive global service for all of our components.

Local address:

### Hydro-Gear

[www.hydro-gear.com](http://www.hydro-gear.com)

### Daikin-Sauer-Danfoss

[www.daikin-sauer-danfoss.com](http://www.daikin-sauer-danfoss.com)

**Danfoss  
Power Solutions (US) Company**  
2800 East 13th Street  
Ames, IA 50010, USA  
Phone: +1 515 239 6000

**Danfoss  
Power Solutions GmbH & Co. OHG**  
Krokamp 35  
D-24539 Neumünster, Germany  
Phone: +49 4321 871 0

**Danfoss  
Power Solutions ApS**  
Nordborgvej 81  
DK-6430 Nordborg, Denmark  
Phone: +45 7488 2222

**Danfoss  
Power Solutions Trading  
(Shanghai) Co., Ltd.**  
Building #22, No. 1000 Jin Hai Rd  
Jin Qiao, Pudong New District  
Shanghai, China 201206  
Phone: +86 21 2080 6201

Danfoss can accept no responsibility for possible errors in catalogues, brochures and other printed material. Danfoss reserves the right to alter its products without notice. This also applies to products already on order provided that such alterations can be made without subsequent changes being necessary in specifications already agreed. All trademarks in this material are property of the respective companies. Danfoss and the Danfoss logotype are trademarks of Danfoss A/S. All rights reserved.