

RV

Relief Valves



Danfoss

Relief Valves

Application Notes

Basic Operation: Relief Valves

Relief valves are pressure limiting devices. They open when the inlet pressure exceeds the pressure setting of the valve, which is derived by pressure acting against a spring force. The point at which the valve begins to open is known as the crack pressure. The force created by the spring can be adjusted to achieve the required pressure setting. There are various types of relief valves available as shown below.

Direct Acting Poppet Type

A direct acting, poppet type relief valve blocks flow from port 1 to 2 until there is sufficient pressure to overcome the spring force and move the poppet off its seat, opening the valve. As the pressure increases, the poppet will be forced further back against the spring allowing more flow to tank. The valve will re-seat when the pressure falls below the pressure setting. Depending on the design, this re-seat pressure could be between 70% and 80% of the pressure setting, commonly referred to as hysteresis. These valves are ideal as system relief valves where the flow across the valve is intermittent and then constant. They provide a cost-effective solution giving low leakage, fast response, and are contamination tolerant. Some models are available with an integrated reverse free flow check or with dampening for smooth and stable response.

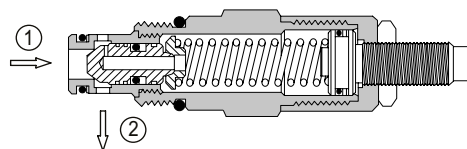
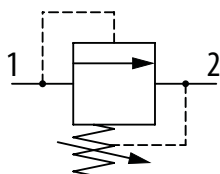

Direct Acting Spool Type

Similar in operation to the poppet type, a spool type design helps to remove instability and offers good control over varying flows at low pressure. These are ideal for use as a purge relief in a closed loop circuit.

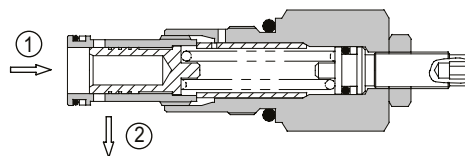
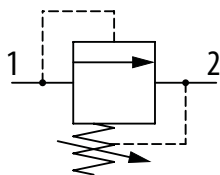

Differential Area Poppet Type

A differential area, poppet type relief valve blocks flow from port 2 to 1 until there is sufficient pressure to open the valve. The pressure acts on the differential area between the seal on the outside diameter on the poppet and the seat diameter, overcoming the spring force to move the poppet off its seat and open the valve. The spring force required to establish high pressure settings is lower, given that it is applied to a smaller area than the direct acting, poppet type valve. These valves are very fast acting, making them ideal for use in clipping pressure spikes.

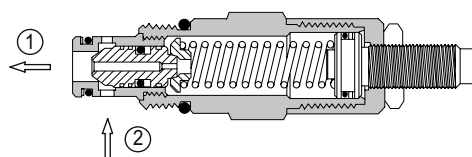
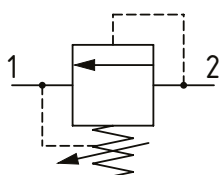

Relief Valves

Application Notes

Bi-Directional Poppet Type

A bi-directional, poppet type valve is a dual cross over relief valve in one cartridge. When the pressure exceeds the setting, the valve will open from port 1 to 2 or port 2 to 1 depending on where the pressure is applied. The pressure setting will be the same in both directions. These are ideal for use as cross over relief valves in motor applications.

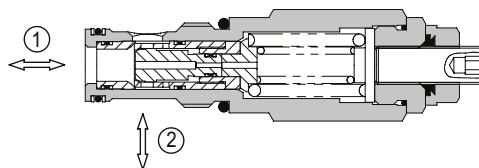
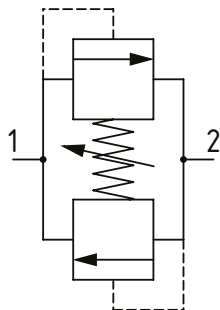

Pilot Operated Spool Type

A pilot operated, spool type relief valve blocks flow from port 1 to 2 until there is sufficient pressure to overcome the spring force and move the poppet off the pilot seat. This creates a pressure differential across the spool, causing the spool to overcome a lighter spring and open the valve. This two-stage design allows for smooth operation at varying flows while maintaining a consistent setting. The re-seat pressure on these valves is between 80% and 90% of the pressure setting. They are capable of higher flows than the direct acting alternative in the same cavity size. They are suited to be main system relief valves where precise pressure control is required. Some models are available with an integrated reverse free flow check.

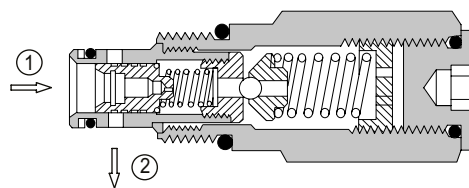
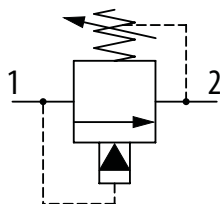

Ventable Pilot Operated Spool Type

A ventable, pilot operated, spool type relief valve blocks flow from port 1 to 2 until there is sufficient pressure to overcome the spring force and move the poppet off the pilot seat. This creates a pressure differential across the spool, causing the spool to overcome a lighter spring and open the valve. This two-stage design allows for smooth operation at varying flows while maintaining a consistent setting. The vent port allows the valve setting to be controlled remotely using a pilot relief valve or a pilot proportional valve. The valve can also be opened at low pressure if the vent port is directed to tank through an external pilot valve. Refer to 'Two pressure system' in Typical Applications below.

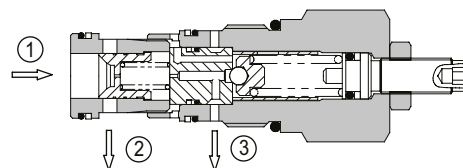
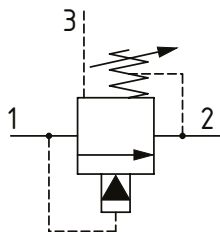

Relief Valves

Application Notes

Relief Valve Comparison

Characteristic \ Type	Direct Acting Spool	Direct Acting Poppet	Direct Acting Damped Poppet	Differential Area Poppet	Pilot Operated Spool
Leakage	-	+	+	+	-
Pressure Rise	-	-	-	+	+
Hysteresis	+	+	+	-	-
Dirt Tolerant	-	+	-	+	-
Fast Acting	-	+	-	+	-
Stable	-	-	+	+	+
Relative Price [1 lowest]	4	2	3	1	5
Rule of Thumb	Charge relief	Limiting Pressure	Regulating, low flow, quiet	Limiting and Regulating pressure	Regulating pressure

Application Recommendations

- All relief valves are designed to limit the pressure in a system.
- Poppet valves limit leakage to <10 drops per min [0.6 ml/min]. The valve will limit leakage up to 80% of the setting with increasing pressure and once open, below the re-seat value as the pressure decreases.
- Pilot operated spool valves will leak as the pressure increases because of the clearance between the spool and the sleeve [typically <100 ml/min].
- Direct acting valves feature a quick response and are good for reducing pressure spikes, while pilot operated valves have a slower response and are good for regulating pressure.
- Pressure setting is defined when a pre-determined flow is passing across the valve. Refer to the specific product for this value.
- When specifying the pressure setting, be aware the the pressure will increase as flow increases across the valve, which is known as pressure rise.
- Pressure in the tank line will increase the Pressure setting made at a 1 to 1 ratio.

Typical Applications

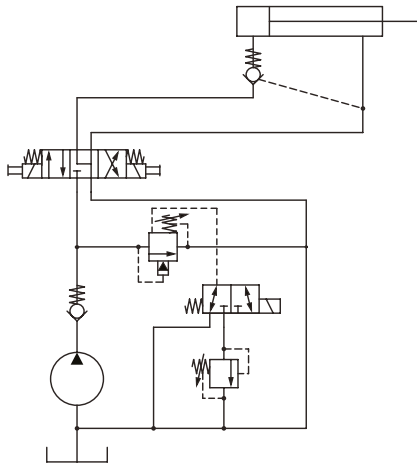

▲ Two Pressure System

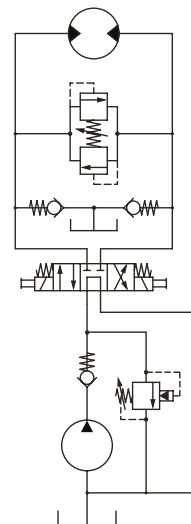

▲ Motor Control

Relief Valves

Quick Reference

Relief Valve	Model No.	Cavity	Description	Flow*	Pressure	Page
	1DR2	SDC08-2	Relief valve, Direct Acting, Poppet Type	1.2 l/min [0.3 US gpm]	400 bar [5800 psi]	7
	1DR30	SDC08-2	Relief valve, Direct Acting, Poppet Type	30 l/min [8 US gpm]	400 bar [5800 psi]	8
	RV08-DR	SDC08-2	Relief Valve, Direct Acting, Poppet Type with Dampening	30 l/min [8 US gpm]	250 bar [3600 psi]	9
	RV1-10	SDC10-2	Relief valve, Direct Acting, Poppet Type	30 l/min [8 US gpm]	250 bar [3600 psi]	10
	VEN 06	NCS06/2	Relief Valve, Direct Acting, Poppet Type with Dampening	40 l/min [11 US gpm]	315 bar [4600 psi]	11
	VME 08	VME 08	Relief Valve, Direct Acting, Poppet Type with Dampening	80 l/min [21 US gpm]	315 bar [4600 psi]	12
	RV1-12	C-12-2 / C-12-2U	Relief valve, Direct Acting, Poppet Type	114 l/min [30 US gpm]	350 bar [5000 psi]	13
	CP210-1	SDC10-2	Relief Valve, Direct Acting, Spool Type	45 l/min [12 US gpm]	210 bar [3000 psi]	14
	CP211-1	CP12-2	Relief Valve, Direct Acting, Spool Type	76 l/min [20 US gpm]	210 bar [3000 psi]	15
	1GR100	A881	Relief Valve, Direct Acting, Spool Type	150 l/min [40 US gpm]	350 bar [5000 psi]	16
Relief Valve	Model No.	Cavity	Description	Flow*	Pressure	Page
	RV8-8	SDC08-2	Relief Valve, Differential Area, Poppet Type	30 l/min [8 US gpm]	350 bar [5000 psi]	17
	CP208-1	SDC08-2	Relief Valve, Differential Area, Poppet Type	40 l/min [11 US gpm]	250 bar [3600 psi]	18
	RV8-10	SDC10-2	Relief Valve, Differential Area, Poppet Type	76 l/min [20 US gpm]	350 bar [5000 psi]	19
	CP200-1	SDC10-2	Relief Valve, Differential Area, Poppet Type	76 l/min [20 US gpm]	250 bar [3600 psi]	20
	RV3-12	C-12-2/C-12-2U	Relief Valve, Differential Area, Poppet Type	132 l/min [35 US gpm]	350 bar [5000 psi]	21
	CP201-1	CP12-2	Relief Valve, Differential Area, Poppet Type	150 l/min [40 US gpm]	250 bar [3600 psi]	22
	RV3-16	SDC16-2	Relief Valve, Differential Area, Poppet Type	300 l/min [80 US gpm]	350 bar [5000psi]	23
	1LR300	A1126	Relief Valve, Differential Area, Poppet Type	380 l/min [100 US gpm]	350 bar [5000 psi]	24
	Relief Valve	Model No.	Cavity	Description	Flow*	Pressure
	RV5-10	SDC10-2	Relief valve, Pilot operated, Spool Type	114 l/min [30 US gpm]	350 bar [5000 psi]	25
	RV11-12	C-12-2 / C-12-2U	Relief valve, Pilot operated, Spool Type	190 l/min [50 US gpm]	350 bar [5000 psi]	26
	1AR100	A881	Relief valve, Pilot operated, Spool Type	150 l/min [40 US gpm]	400 bar [5800 psi]	27
	RV5-16	SDC16-2	Relief valve, Pilot operated, Spool Type	300 l/min [80 US gpm]	350 bar [5000 psi]	28

*Flow ratings are for reference only. Refer to individual product page for performance information.

Relief Valves

Quick Reference

Relief Valve	Model No.	Cavity	Description	Flow*	Pressure	Page
	1ARD100	A881	Relief Valve, Pilot operated, Spool Type, Anti-Shock	100 l/min [26 US gpm]	210 bar [3000 psi]	29
	RV2-10	SDC10-2	Relief valve, Pilot Operated, Spool Type with Reverse Free Flow	114 l/min [30 US gpm]	350 bar [5000 psi]	30
	RV10-POP	SDC10-2	Relief valve, Pilot Operated, Spool Type with Reverse Free Flow	120 l/min [32 US gpm]	250 bar [3600 psi]	31
	1ARC100	A881	Relief valve, Pilot Operated, Spool Type with Reverse Free Flow	150 l/min [40 US gpm]	400 bar [5800 psi]	32
	1VR100	A3146	Relief Valve, Pilot Operated, Spool Type, Ventable	100 l/min [26 US gpm]	350 bar [5000 psi]	33
	1VR200	A16102	Relief Valve, Pilot Operated, Spool Type, Ventable	200 l/min [52 US gpm]	350 bar [5000 psi]	34
	CP200-7	SDC10-2	Relief Valve, Differential Area, Poppet Type, Bi-directional	40 l/min [11 US gpm]	250 bar [3600 psi]	35
	1CLLR100	A878	Relief Valve, Differential Area, Poppet Type, Bi-directional	150 l/min [40 US gpm]	350 bar [5000 psi]	36
	CP220-1	Catalog HIC	Cross-Over Relief Valve, Line Mounted	76 l/min [20 US gpm]	250 bar [3600 psi]	37
	CP221-1	Catalog HIC	Cross-Over Relief Valve, Line Mounted	150 l/min [40 US gpm]	250 bar [3600 psi]	38

*Flow ratings are for reference only. Refer to individual product page for performance information.

Relief Valves

1DR2

Relief valve, Direct Acting, Poppet Type

400 bar [5800 psi] • 1.2 l/min [0.3 US gpm]

DESCRIPTION AND OPERATION

This is a direct acting, pilot, poppet type relief valve that relieves from port 1 to 2. It can be used as a thermal relief or in conjunction with other valves as a pilot relief.

SCHEMATIC

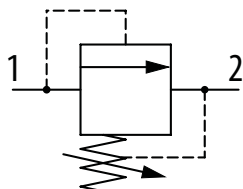

PERFORMANCE DATA

Rated pressure	400 bar [5800 psi]
Rated flow	1.2 l/min [0.3 US gpm]
Leakage	0.3 ml/min nominal [5 drops/min]
Weight	0.14 kg [0.30 lb]
Cavity	SDC08-2

MODEL CODE

1DR2 - P - 3W - 40 - S - 377 - 60

Basic Code

1DR2 - No Housing
1DR22 - Cartridge and housing

Adjustment Option

P - External
R - Knob
G - Tamper resistant

Housing

Code	Ports	Housing Model Code	
		Aluminum	Steel
Omit		No Housing	
2W	1/4" BSP	A1485	
3W	3/8" BSP	A1043	A14175
6T	3/8" SAE	A15676	A14843

* Aluminum bodies are to be used for pressures less than 210 bar [3000 psi].
* Additional housings available

DIMENSIONS

mm [in]

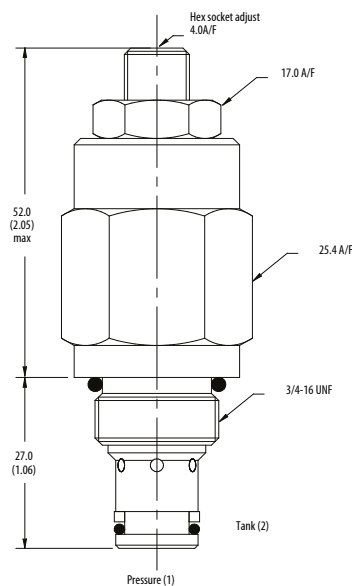

Installation torque

A - 47-54 Nm [35-40 ft. lbs]
S - 68-75 Nm [50-55 ft. lbs]

PERFORMANCE CURVES

Pressure Override

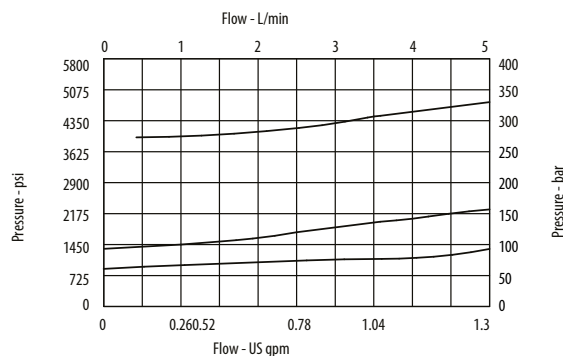

Pressure Range

Code	Bar	Psi
10	7-100	[100-1450]
Standard Setting	70	[1015]
20	35-210	[500-3000]
Standard Setting	100	[1450]
40	50-400	[725-5800]
Standard Setting	280	[4060]

Pressure setting made at 0.5 l/min

Relief Valves

1DR30

Relief valve, Direct Acting, Poppet Type

400 bar [5800 psi] • 30 l/min [8 US gpm]

DESCRIPTION AND OPERATION

This is a direct acting, poppet type relief valve that relieves from port 1 to 2. It can be used as a cost-effective main relief or to protect an actuator from over-pressurization.

SCHEMATIC

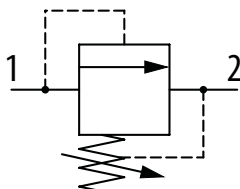

PERFORMANCE DATA

Rated pressure	400 bar [5800 psi]
Rated flow	30 l/min [8 US gpm]
Leakage	0.3 ml/min nominal [5 drops/min]
Weight	0.17 kg [0.37 lb]
Cavity	SDC08-2

MODEL CODE

1DR30 - P - 3W - 40 - S - 377 - 60

Basic Code

1DR30 - No Housing
1DR35 - Cartridge and housing

Adjustment Option

P - External
R - Knob
G - Tamper resistant

Housing

Code	Ports	Housing Model Code	
		Aluminum	Steel
Omit	No Housing		
2W	1/4" BSP	A1485	
3W	3/8" BSP	A1043	A14175
6T	3/8" SAE	A15676	A14843

* Aluminum bodies are to be used for pressures less than 210 bar [3000 psi].

* Additional housings available

DIMENSIONS

mm [in]

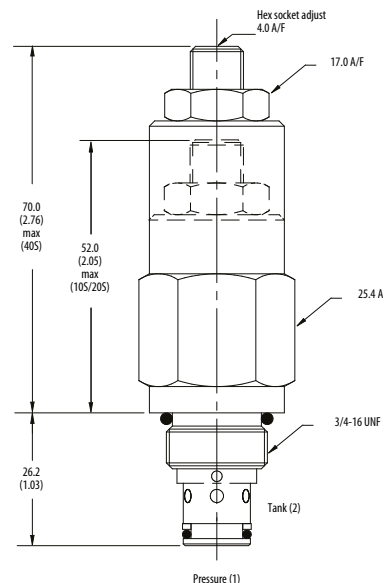

Installation torque

A - 47-54 Nm [35-40 ft. lbs]

S - 68-75 Nm [50-55 ft. lbs]

PERFORMANCE CURVES

Pressure Override

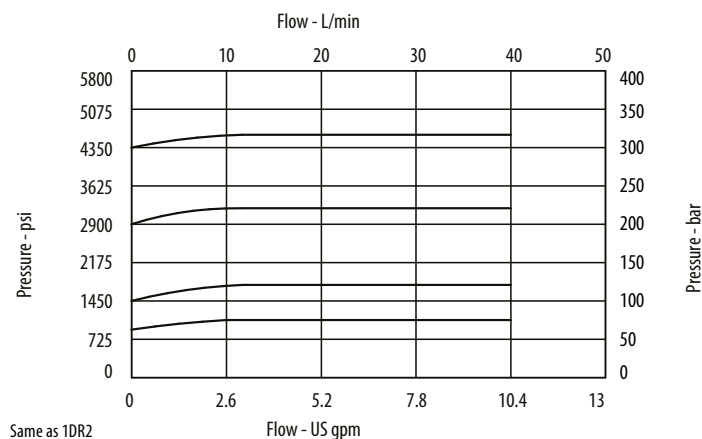

Same as 1DR2

Housing Material		
Omit	Aluminum/No housing	
377	Steel	

Seal Option		
Code	Seal Kit	
S-Nitrile	SK243	
SV-Viton®	SK243V	

Pressure Range		
Code	Bar	Psi
10	7-100	[100-1450]
Standard Setting	70	[1015]
20	35-210	[500-3000]
Standard Setting	100	[1450]
40	50-400	[725-5800]
Standard Setting	280	[4060]

Pressure Setting		
Code	Bar	Psi
60	60	[870]

Code - Pressure setting in bar (5 bar increments within specified Pressure Range)
 XXX - Standard setting (see Pressure Range for value)
 Example:

Pressure setting made at 4.8 l/min

Relief Valves

RV08-DR

Relief Valve, Direct Acting, Poppet Type with Dampening

250 bar [3600 psi] • 30 l/min [8 US gpm]

DESCRIPTION AND OPERATION

This is a direct acting, poppet type relief valve that relieves from port 1 to 2. It features a highly damped poppet for smooth and stable response. It can be used as a cost-effective main relief or to protect an actuator from over-pressurization.

SCHEMATIC

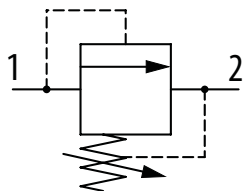

DIMENSIONS

mm [in]

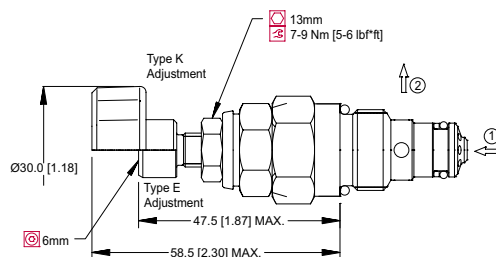
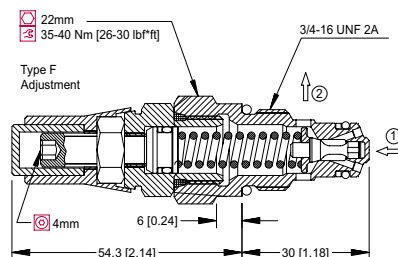

PERFORMANCE DATA

Rated pressure	250 bar [3600 psi]
Rated flow	30 l/min [8 US gpm]
Leakage	10 drops/min @ 80% of Pressure Setting
Weight	0.10 kg [0.22 lb]
Cavity	SDC08-2

PERFORMANCE CURVES

Pressure Override

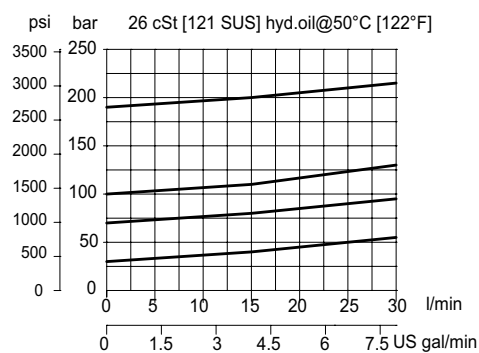

MODEL CODE

RV08 - DR - 1 - E - 60 - B - 4S

Pressure Range

Code	Bar	Psi
1	20-80	[290-1150]
Standard Setting	Not set	
2	35-160	[510-2300]
Standard Setting	Not set	
3	60-250	[870-3600]
Standard Setting	Not set	

Adjustment Option

E - External
F - Tamper resistant
K - Knob

Pressure Setting

Code-Pressure setting in bar (5 bar increments within specified Pressure Range)
XXX-Standard setting (see Pressure Range for value)

Example:

Code	Bar	Psi
60	60	[870]

Housing

Code	Ports & Material	Housing Model Code
00	No Housing	No Housing
DG2B	Al, 1/4 BSP	SDC08-2-DG-2B
DG3B	Al, 3/8 BSP	SDC08-2-DG-3B
4S	Al, #4 SAE	CP08-2-4S
6S	Al, #6 SAE	CP08-2-6S

* Aluminum bodies are to be used for pressures less than 210 bar [3000 psi].
* Additional housings available

Seal Option

Code	Seal kit
B-Buna - N	354000119
V-Viton	354000219

Relief Valves

RV1-10

Relief valve, Direct Acting, Poppet Type

250 bar [3600 psi] • 30 l/min [8 US gpm]

DESCRIPTION AND OPERATION

This is a direct acting, poppet type relief valve that relieves from port 1 to 2. It can be used as a cost-effective main relief or to protect an actuator from over-pressurization.

SCHEMATIC

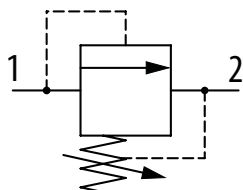

PERFORMANCE DATA

Rated pressure	250 bar [3600 psi]
Rated flow	30 l/min [8 US gpm]
Leakage	0.3 ml/min [5 drops/min] @ 85% of Pressure Setting
Weight	0.22 kg [0.48 lb]
Cavity	SDC10-2

MODEL CODE

RV1 - 10 - V - C - S - 2G - 3 - 10

Seal Option

Code	Seal Kit
B-Buna - N	565803
V-Viton	566086

Adjustment Option

C - Tamper Resistant
F - Fixed
I - Internal
K - Knob
S - External

Housing Material

Omit - Aluminum/No Housing
S - Steel

Housing

Code	Ports	Housing Model Code		
		Aluminum Standard Duty	Aluminum Heavy Duty	Steel Heavy Duty
0	No Housing			
3B	3/8" BSP	02-175462	-	-
2G	1/4" BSP	-	876702	02-175102
3G	3/8" BSP	-	876703	02-175103
6H	#6 SAE	-	876700	-
8H	#8 SAE	-	876701	-
6T	#6 SAE	566151	-	02-175100
8T	#8 SAE	-	-	02-175101

Pressure Setting

Code x100 - Pressure setting in psi (50 psi increments within specified Pressure Range)
XXX-Standard setting (see Pressure Range for value)
Examples:

Code	Bar	Psi
10	69	[1000]
10.5	72.4	[1050]

Pressure Range

Code	Bar	Psi
3	3.5-20	[50-300]
Standard Setting	10.3	[150]
9	7-62	[100-900]
Standard Setting	31	[450]
18	17-124	[250-1800]
Standard Setting	62	[900]
30	34-210	[600-3000]
Standard Setting	103	[1500]
36	124-250	[1800-3600]
Standard Setting	124	[1800]

* Aluminum bodies are to be used for pressures less than 210 bar [3000 psi].

* Additional housings available

DIMENSIONS

mm [in]

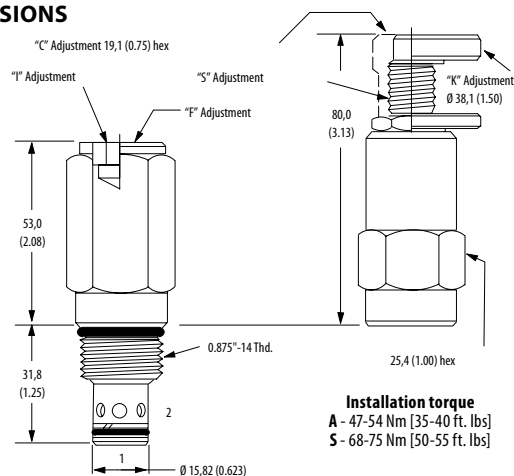

PERFORMANCE CURVES

Pressure Override

Flow - L/min (21/8 cSt oil @ 49°C)

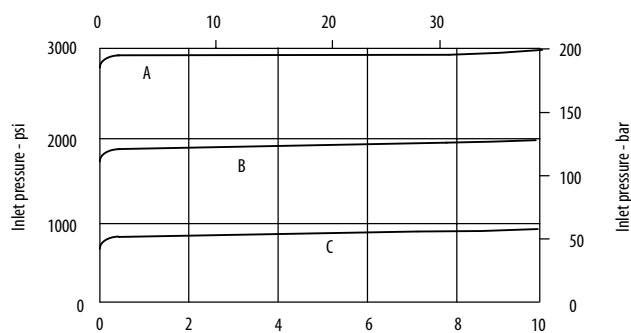

Flow - USgpm (105 SUS oil @ 120°F)

A - 36 spring • B - 18 spring • C - 9 spring

Relief Valves

VEN 06

Relief Valve, Direct Acting, Poppet Type with Dampening

315 bar [4600 psi] • 40 l/min [11 US gpm]

DESCRIPTION AND OPERATION

This is a direct acting, poppet type relief valve that relieves from port 1 to 2. It features a highly damped poppet for smooth and stable response. It can be used as a cost-effective main relief or to protect an actuator from over-pressurization.

SCHEMATIC

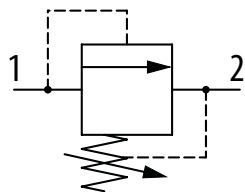

DIMENSIONS

mm [in]

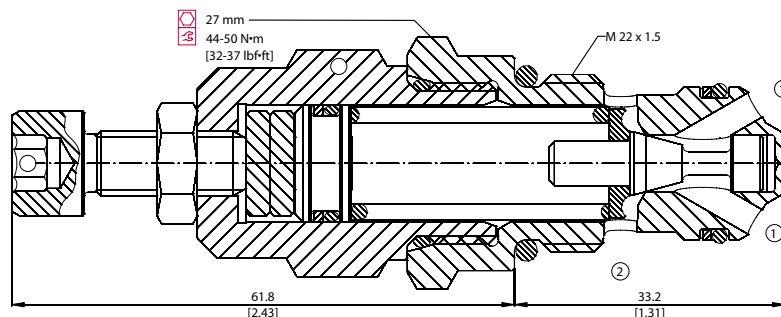

PERFORMANCE DATA

Rated pressure	315 bar [4600 psi]
Rated flow	40 l/min [11 US gpm]
Weight	0.20 kg [0.44 lb]
Cavity	NCS06/2

PERFORMANCE CURVES

Pressure Override

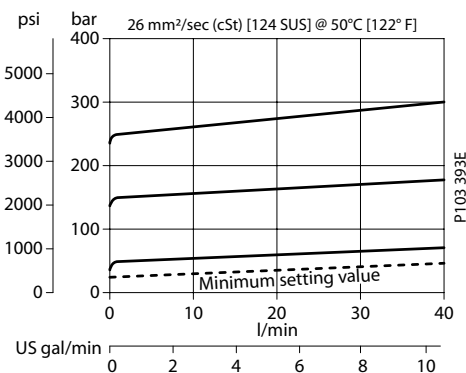

MODEL CODE

VEN 06 - M - 1 - DG3/8 - V - 60

Adjustment Option

EN - External
M - Calibrated Knob

Pressure Range

Code	Bar	Psi
1	20-80	[290-1150]
Standard Setting		Not set
2	35-160	[510-2300]
Standard Setting		Not set
3	70-315	[1015-4600]
Standard Setting		Not set

Pressure Setting

Code - Pressure setting in bar (5 bar increments within specified Pressure Range)

XXX - Standard setting (see Pressure Range for value)

Example:

Seal Option

Code Seal kit
Omit-Buna-N 230000060
V-Viton 230000380

Code	Bar	Psi
60	60	[870]

Housing

Code	Ports & Material	Housing Model Code
00	No Housing	No Housing
DG3/8	AL, 3/8 BSP	NCS06/2-DG-3/8
DG1/2	AL, 1/2 BSP	NCS06/2-DG-1/2
DG65	AL, #6 SAE	NCS06/2-DG-65
DG85	AL, #8 SAE	NCS06/2-DG-85

* Aluminum bodies are to be used for pressures less than 210 bar [3000 psi].

*Additional housings available

Relief Valves

VME 08

Relief Valve, Direct Acting, Poppet Type with Dampening

315 bar [4600 psi] • 80 l/min [21 US gpm]

DESCRIPTION AND OPERATION

This is a direct acting, poppet type relief valve that relieves from port 1 to 2. It features a highly damped poppet for smooth and stable response. It can be used as a cost-effective main relief or to protect an actuator from over-pressurization.

SCHEMATIC

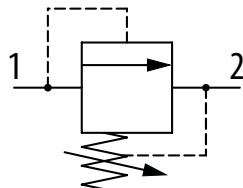

DIMENSIONS

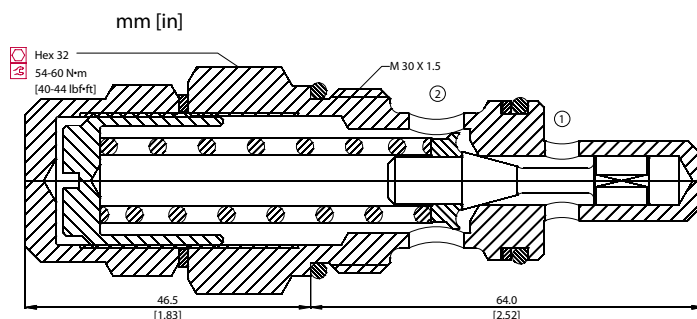

PERFORMANCE DATA

Rated pressure	315 bar [4600 psi]
Rated flow	80 l/min [21 US gpm]
Weight	0.35 kg [0.77 lb]
Cavity	VME08

PERFORMANCE CURVES

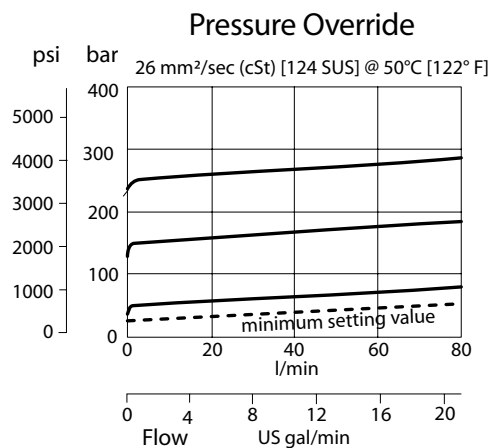

MODEL CODE

VME08 - E - 2 - DG3/4 - V - 60

Adjustment Option

EN - External
M - Calibrated Knob

Pressure Range

Code	Bar	Psi
1	25-80	[360-1150]
Standard Setting		Not set
2	35-160	[510-2300]
Standard Setting		Not set
3	70-315	[1015-4600]
Standard Setting		Not set

Pressure Setting

Code - Pressure setting in bar (5 bar increments within specified Pressure Range)
XXX - Standard setting (see Pressure Range for value)
Example:

Code	Bar	Psi
60	60	[870]

Seal Option

Code	Seal kit
Omit-Buna-N	230000140
V-Viton	Consult factory

Housing

Code	Ports & Material	Housing Model Code
00	No Housing	No Housing
DG3/4	AL, 3/4 BSP	VME08-DG-3/4
DG12S	AL, #12 SAE	VME08-DG-12S

* Aluminum bodies are to be used for pressures less than 210 bar [3000 psi].

* Additional housings available

Relief Valves

RV1-12

Relief valve, Direct Acting, Poppet Type

350 bar [5000 psi] • 114 l/min [30 US gpm]

DESCRIPTION AND OPERATION

This is a direct acting, poppet type relief valve that relieves from port 1 to 2. It can be used as a cost-effective main relief or to protect an actuator from over-pressurization.

SCHEMATIC

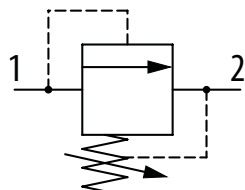

PERFORMANCE DATA

Rated pressure	350 bar [5000 psi]
Rated flow	114 l/min [30 US gpm]
Leakage	5 drops/min @ 80% of pressure setting
Weight	0.49 kg [1.08 lb]
Cavity	C-12-2 or C-12-2U

MODEL CODE

RV1 - 12 - V - C - A - 4G - U - 2.5 - 10

Seal Option

Code	Seal Kit
Omit - Buna - N	02-165881
V - Viton	02-165888

Adjustment Option

C - Tamper Resistant
F - Fixed
K - Knob
S - External

Housing Material

Omit - No Housing
A - Aluminum
S - Steel

Housing

Code	Ports	Housing Model Code			
		C-12-2 Aluminum Heavy Duty	C-12-2U Aluminum Heavy Duty	C-12-2 Steel Heavy Duty	C-12-2U Steel Heavy Duty
Omit	No Housing				
4G	1/2" BSP	02-161118	02-161116	02-172062	02-172512
6G	1/4" BSP	02-161117	02-161115	02-169665	02-162922
10T	#10 SAE	02-160640	02-160641	02-169744	02-169817
12T	#12 SAE	02-160644	02-160645	02-169782	02-169790

* Aluminum bodies are to be used for pressures less than 210 bar [3000 psi].

* Additional housings available

Pressure Setting

Code x100 - Pressure setting in psi
(50 psi increments within specified Pressure Range)
XXX - Standard setting (see Pressure Range for value)
Examples:

Code	Bar	Psi
10	69	[1000]
10.5	72.4	[1050]

Pressure Range

Code	Bar	Psi
2.5	3.4-17	[50-250]
Standard Setting	8.6	[125]
8.5	13-55	[200-850]
Standard Setting	29	[425]
22	20-150	[300-2200]
Standard Setting	76	[1100]
40	40-275	[600-4000]
Standard Setting	138	[2000]

Cavity

Omit - Cavity without undercut/No housing
U - Cavity with undercut

DIMENSIONS

mm [in]

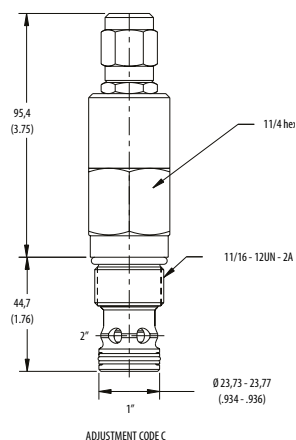

Installation torque

A - 81-95 Nm [60-70 ft. lbs]
S - 102-115 Nm [75-85 ft. lbs]

PERFORMANCE CURVES

Pressure Override

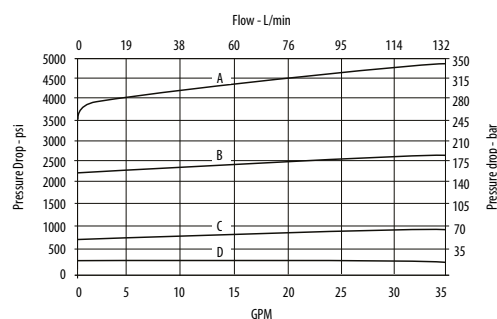

A - 40 spring • B - 22 spring • C - 8.5 spring • D - 2.5 spring

Relief Valves

CP210-1

Relief Valve, Direct Acting, Spool Type

210 bar [3000 psi] • 45 l/min [12 US gpm]

DESCRIPTION AND OPERATION

This is a direct acting spool, type relief valve that relieves from port 1 to 2. It has been designed to give stable performance at lower pressure and can be used as a purge relief, bypass filter elements or in applications that require better control.

SCHEMATIC

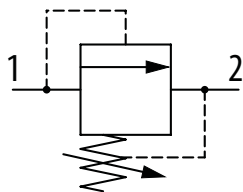

DIMENSIONS

mm [in]

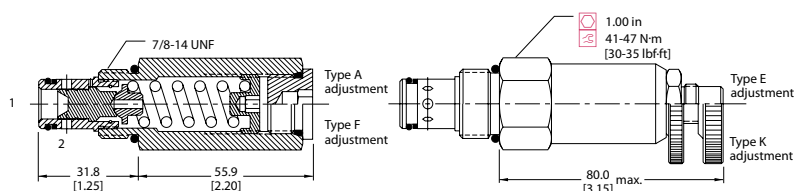

PERFORMANCE DATA

Rated pressure	210 bar [3000 psi]
Rated flow	45 l/min [12 US gpm]
Leakage	82 ml/min [5 in ³ /min] @ 80% of Pressure Setting
Weight	0.22 kg [0.48 lb]
Cavity	SDC10-2

PERFORMANCE CURVES

Pressure Override

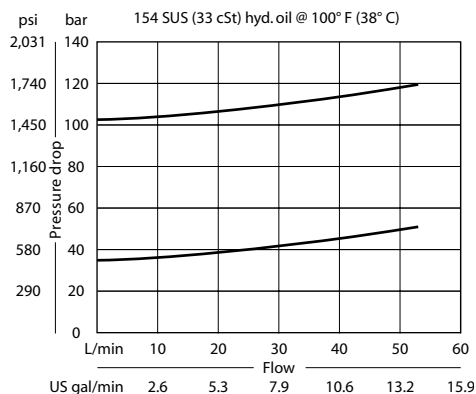

MODEL CODE

CP210 - 1 - B - 6S - A - C - 075

Seal Option

Code	Seal kit
B -Buna - N	120015
V -Viton	120016

Housing

Code	Ports & Material	Housing Model Code
0	No Housing	No Housing
DG3B	AL, 3/8 BSP	SDC10-2-DG-3B
DG4B	AL, 1/2 BSP	SDC10-2-DG-4B
6S	AL, #6 SAE	CP10-2-6S
8S	AL, #8 SAE	CP10-2-8S

* Aluminum bodies are to be used for pressures less than 210 bar [3000 psi].

*Additional housings available

Adjustment Option

A - Internal
E - External
F - Tamper resistant
K - Knob

Pressure Setting

Example:

Code	Bar	Psi
075	52	[750]

Code x10 - Pressure setting in psi (50 psi increments within specified Pressure Range)
XXX - Standard setting (see Pressure Range for value)

Pressure Range

Code	Bar	Psi
A Standard Setting	3.4-28 17	[50-400] [250]
B Standard Setting	5.5-55 28	[80-800] [400]
C Standard Setting	6.9-97 52	[100-1400] [750]
D Standard Setting	34-166 103	[500-2400] [1500]

Relief Valves

CP211-1

Relief Valve, Direct Acting, Spool Type

210 bar [3000 psi] • 76 l/min [20 US gpm]

DESCRIPTION AND OPERATION

This is a direct acting spool, type relief valve that relieves from port 1 to 2. It has been designed to give stable performance at lower pressure and can be used as a purge relief, bypass filter elements or in applications that require better control.

SCHEMATIC

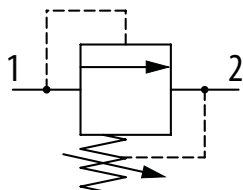

DIMENSIONS

mm [in]

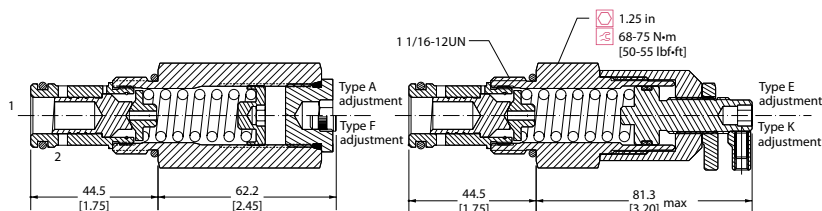

PERFORMANCE DATA

Rated pressure	210 bar [3000 psi]
Rated flow	76 l/min [20 US gpm]
Max Pressure Setting	41 bar [600 psi]
Leakage	82 ml/min [5 in ³ /min] @ 80% of Pressure Setting
Weight	0.41 kg [0.90 lb]
Cavity	CP12-2

PERFORMANCE CURVES

Pressure Override

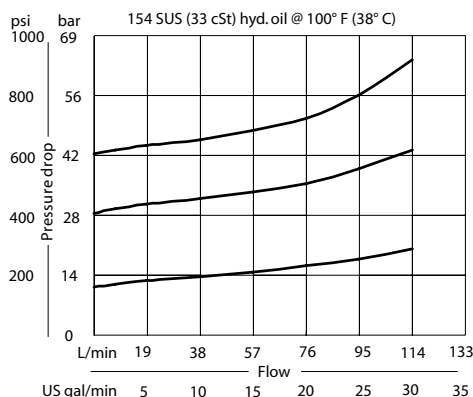

MODEL CODE

CP211 - 1 - B - 10S - A - C - 040

Seal Option

Code	Seal kit
B-Buna - N	120017
V-Viton	120018

Housing

Code	Ports & Material	Housing Model Code
0	No Housing	No Housing
4B	AL, 1/2 BSP	CP12-2-4B
6B	AL, 3/4 BSP	CP12-2-6B
10S	AL, #10 SAE	CP12-2-10S
12S	AL, #12 SAE	CP12-2-12S

* Aluminum bodies are to be used for pressures less than 210 bar [3000 psi].

*Additional housings available

Pressure Setting

Example:

Code	Bar	Psi
040	28	[400]

Code x10 - Pressure setting in psi (50 psi increments within specified Pressure Range)
 XXX-Standard setting (see Pressure Range for value)

Pressure Range

Code	Bar	Psi
A	0-10.3	[0-150]
Standard Setting	7	[100]
B	3.4-34	[50-400]
Standard Setting	21	[300]
C	5.2-41	[80-600]
Standard Setting	28	[400]

Adjustment Option

A - Internal
 E - External
 F - Tamper resistant
 K - Knob

Relief Valves

1GR100

Relief Valve, Direct Acting, Spool Type

350 bar [5000 psi] • 150 l/min [40 US gpm]

DESCRIPTION AND OPERATION

This is a direct acting spool, type relief valve that relieves from port 1 to 2. It has been designed to give stable performance at lower pressure and can be used as a purge relief, bypass filter elements or in applications that require better control.

SCHEMATIC

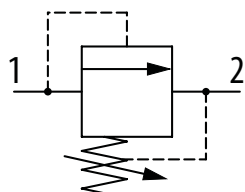

PERFORMANCE DATA

Rated pressure	350 bar [5000 psi]
Rated flow	150 l/min [40 US gpm]
Max Pressure Setting	40 bar [580 psi]
Leakage	15 ml/min nominal
Weight	0.31 kg [0.7 lb]
Cavity	A881

MODEL CODE

1GR100 - P - 3W - 0.6 - S - 377 - 60

Basic Code

1GR100 - No housing
1GR145 - Cartridge and housing
1GR150 - Cartridge and housing
 Through Ported
1GR155 - Cartridge and housing
 Through Ported

Adjustment Option

P - External
R - Knob
G - Tamper resistant

Housing

Code	Ports	Housing Model Code				
		Aluminum 1GR145	Aluminum 1GR150	Steel 1GR150	Aluminum 1GR155	Steel 1GR155
Omit	No Housing					
3W	3/8" BSP		C1084			
4W	1/2" BSP	B4851	C1044	C593		
6W	3/4" BSP	B3954	C1086	C4917		
8W	1" BSP				B1617	B4596
6T	3/8" SAE		B10784			
8T	1/2" SAE	B19403	C7140			
12T	3/4" SAE	B19404	B10506	B10742		
16T	1" SAE				B1037	B24040

Pressure Setting

Code - Pressure setting in bar
 (5 bar increments within
 specified Pressure Range)
XXX - Standard setting
 (see Pressure Range for value)
 Example:

Code	Bar	Psi
60	60	[870]

Housing Material

Omit - Aluminum/No housing
377 - Steel

Seal Option

Code	Seal Kit
S - Nitrile	SK190
SV - Viton	SK190V

Pressure Range

Code	Bar	Psi
0.6	0.3-6	[4.3-90]
Standard Setting	6	[90]
2	5-25	[75-360]
Standard Setting	20	[290]
4	5-40	[75-580]
Standard Setting	28	[400]

Pressure setting made at 4.8 l/min

* Aluminum bodies are to be used for pressures less than 210 bar [3000 psi].

* Additional housings available

DIMENSIONS

mm [in]

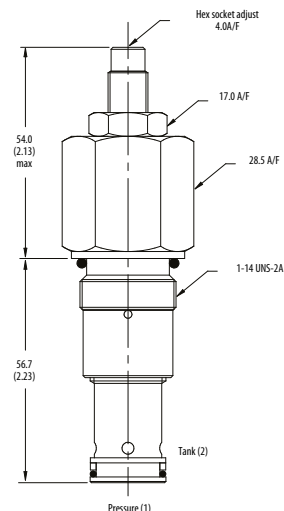

Installation torque
 60 Nm [44 ft. lbs.]

PERFORMANCE CURVES

Pressure Override

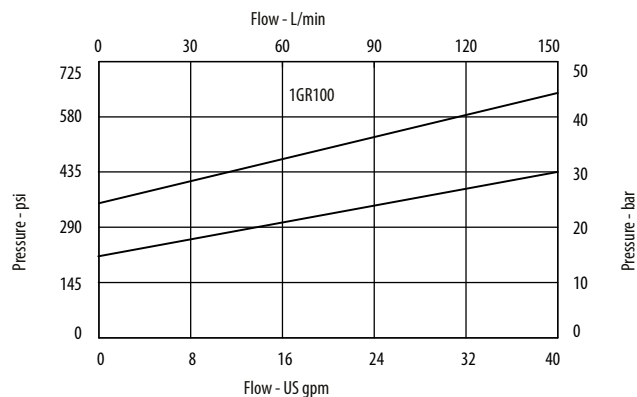

Relief Valves

RV8-8

Relief Valve, Differential Area, Poppet Type

350 bar [5000 psi] • 30 l/min [8 US gpm]

DESCRIPTION AND OPERATION

This is a fast acting, differential area, poppet type relief valve that relieves from port 2 to 1. It can be used to protect an actuator from over pressurization or to remove pressure spikes.

SCHEMATIC

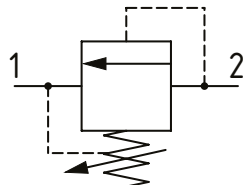

PERFORMANCE DATA

Rated pressure	350 bar [5000 psi]
Rated flow	30 l/min [8 US gpm]
Leakage	5 drops/min @ 80% of cracking pressure
Weight	0.20 kg [0.43 lb]
Cavity	SDC08-2

MODEL CODE

RV8 - 8 - V - C - A - 2G - 15 - 15

Seal Option

Code	Seal Kit
Omit-Buna - N	02-165874
V-Viton	02-165877

Adjustment Option

C - Tamper Resistant
K - Knob
S - External

Housing Material

Omit - No Housing
S - Steel
A - Aluminum

Housing

Code	Ports	Housing Model Code	
		Aluminum Heavy Duty	Steel Heavy Duty
0	No Housing		
4T	#4 SAE	02-160730	02-160736
6T	#6 SAE	02-160731	02-160737
8T	#8 SAE	02-160732	02-160738
2G	1/4" BSP	02-160727	02-160733
3G	3/8" BSP	02-160728	02-160734

* Aluminum bodies are to be used for pressures less than 210 bar [3000 psi].

* Additional housings available

DIMENSIONS

mm [in]

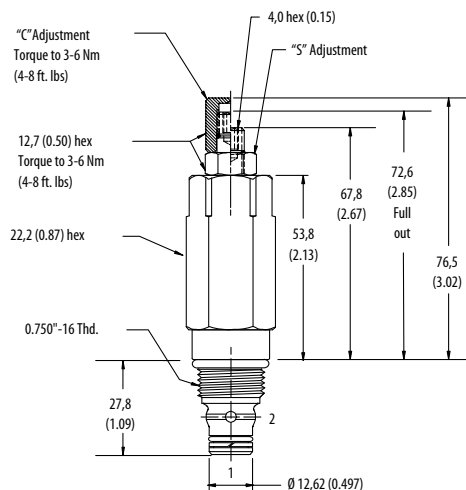

Installation torque
34-41 Nm [25-30 ft lbs]

PERFORMANCE CURVES

Pressure Override

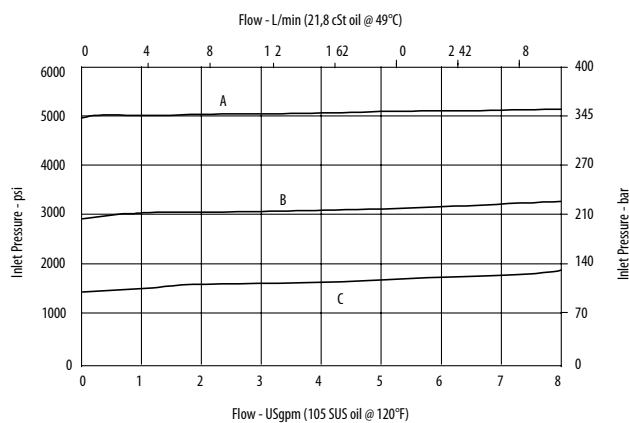

A - 50 spring • B - 30 spring • C - 15 spring

Pressure Setting

Code x100 - Pressure setting in psi
(100 psi increments within specified Pressure Range)
XXX-Standard setting (see Pressure Range for value)
Example:

Code	Bar	Psi
15	103	[1500]

Pressure Range

Code	Bar	Psi
15	3.4-100	[50-1500]
Standard Setting	52	[750]
30	70-210	[1000-3000]
Standard Setting	103	[1500]
50	70-350	[1000-5000]
Standard Setting	175	[2500]

Relief Valves

CP208-1

Relief Valve, Differential Area, Poppet Type

250 bar [3600 psi] • 40 l/min [11 US gpm]

DESCRIPTION AND OPERATION

This is a fast acting, differential area, poppet type relief valve that relieves from port 2 to 1. It can be used to protect an actuator from over-pressurization or to remove pressure spikes.

SCHEMATIC

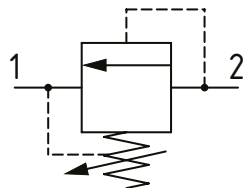

DIMENSIONS

mm [in]

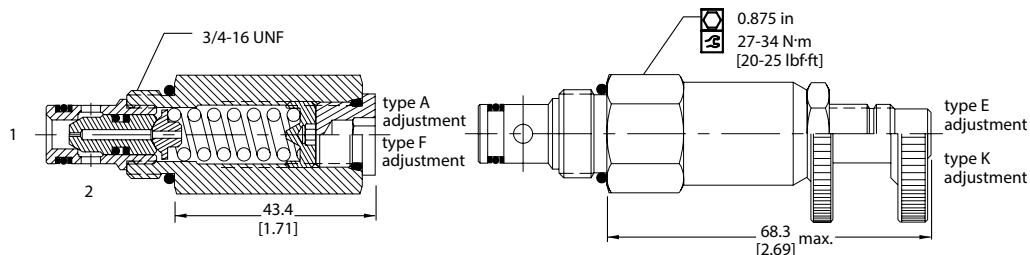

PERFORMANCE DATA

Rated pressure	250 bar [3600 psi]
Rated flow	40 l/min [11 US gpm]
Leakage	10 drops/min @ 80% of pressure setting
Weight	0.15 kg [0.32 lb]
Cavity	SDC08-2

PERFORMANCE CURVES

Pressure Override

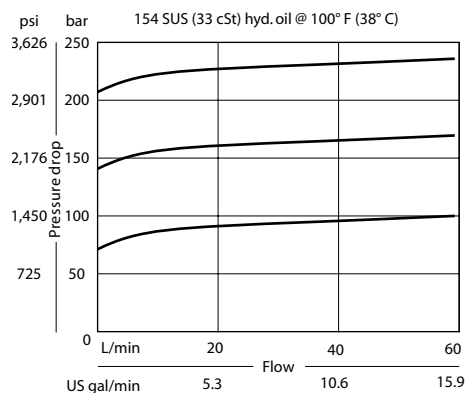

MODEL CODE

CP208 - 1 - B - 6S - A - C - 150

Seal Option

Code	Seal kit
B-Buna-N	120227
V-Viton	120228

Housing

Code	Ports & Material	Housing Model Code
0	No Housing	No Housing
DG2B	AL, 1/4 BSP	SDC08-2-DG-2B
DG2B	AL, 3/8 BSP	SDC08-2-DG-3B
4S	AL, #4 SAE	CP08-2-4S
6S	AL, #6 SAE	CP08-2-6S

* Aluminum bodies are to be used for pressures less than 210 bar [3000 psi]. * Additional housings available

Adjustment Option

A - Internal
E - External
F - Tamper resistant
K - Knob

Pressure Setting

Code x10 - Pressure setting in psi (50 psi increments within specified Pressure Range)
XXX-Standard setting (see Pressure Range for value)
Example:

Code	Bar	Psi
150	103	[1500]

Pressure Range

Code	Bar	Psi
A	7-69	[100-1000]
Standard Setting	28	[400]
B	14-138	[200-2000]
Standard Setting	69	[1000]
C	35-250	[500-3600]
Standard Setting	103	[1500]

Relief Valves

RV8-10

Relief Valve, Differential Area, Poppet Type

350 bar [5000 psi] • 76 l/min [20 US gpm]

DESCRIPTION AND OPERATION

This is a fast acting, differential area, poppet type relief valve that relieves from port 2 to 1. It can be used to protect an actuator from over pressurization or to remove pressure spikes.

SCHEMATIC

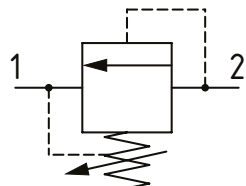

PERFORMANCE DATA

Rated pressure	350 bar [5000 psi]
Rated flow	76 l/min [20 US gpm]
Leakage	0.3 ml/min [5 drops/min] @ 85% of Pressure Setting
Weight	0.22 kg [0.48 lb]
Cavity	SDC10-2

MODEL CODE

RV8 - A - 10 - V - C - S - 2G - 4 - 10

Seal Configuration

Omit - Single back-up ring as shown

A - 1/2 thickness back-up ring on each side of o-ring (for cross port relief applications)

Seal Option

Code	Seal Kit
Omit-Buna - N	565803
V-Viton	566086

Adjustment Option

C - Tamper Resistant
F - Fixed
K - Knob
S - External
I - Internal

Housing Material

Omit - Aluminum/No housing
S - Steel

Housing

Code	Ports	Housing Model Code		
		Aluminum Standard Duty	Aluminum Heavy Duty	Steel Heavy Duty
0	No Housing			
3B	3/8" BSP	02-175462	-	-
2G	1/4" BSP	-	876702	02-175102
3G	3/8" BSP	-	876703	02-175103
6H	#6 SAE	-	876700	-
8H	#8 SAE	-	876701	-
6T	#6 SAE	566151	-	02-175100
8T	#8 SAE	-	-	02-175101

Pressure Setting

Code x100 - Pressure setting in psi (50 psi increments within specified Pressure Range)
XXX-Standard setting (see Pressure Range for value)
Example:

Code	Bar	Psi
10	69	[1000]
10.5	72.4	[1050]

Pressure Range

Code	Bar	Psi
4	3.45-30	[50-450]
Standard Setting	15.5	[225]
12	7-86	[100-1250]
Standard Setting	43	[625]
25	17-175	[250-2500]
Standard Setting	86	[1250]
50	38-350	[550-5000]
Standard Setting	172	[2500]

* Aluminum bodies are to be used for pressures less than 210 bar [3000 psi].

* Additional housings available

DIMENSIONS

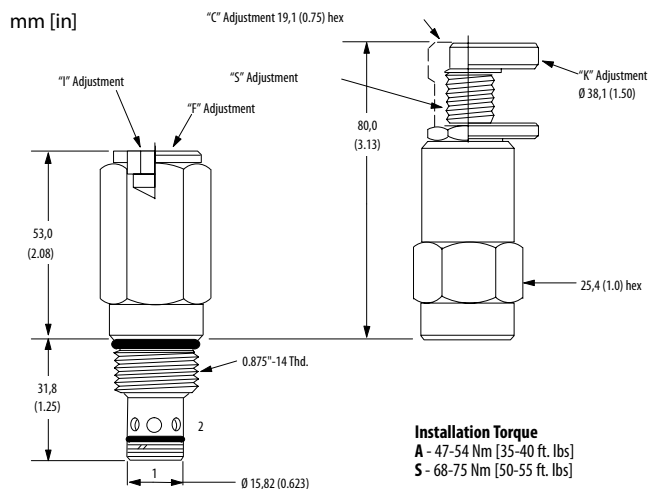

PERFORMANCE CURVES

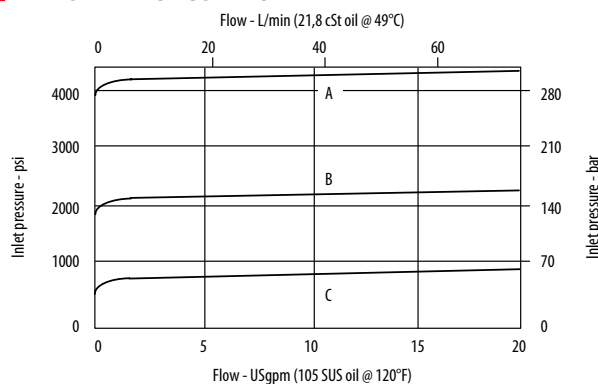

Relief Valves

CP200-1

Relief Valve, Differential Area, Poppet Type

250 bar [3600 psi] • 76 l/min [20 US gpm]

DESCRIPTION AND OPERATION

This is a fast acting, differential area, poppet type relief valve that relieves from port 2 to 1. It can be used to protect an actuator from over-pressurization or to remove pressure spikes.

SCHEMATIC

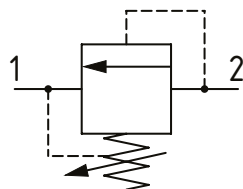

DIMENSIONS

mm [in]

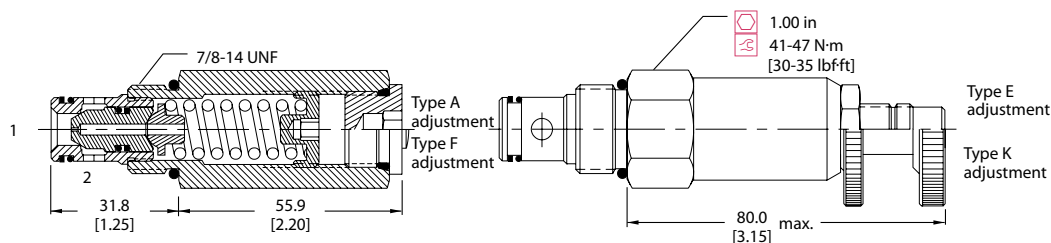

PERFORMANCE DATA

Rated pressure	250 bar [3600 psi]
Rated flow	76 l/min [20 US gpm]
Leakage	10 drops/min @ 80% of pressure setting
Weight	0.21 kg [0.46 lb]
Cavity	SDC10-2

PERFORMANCE CURVES

Pressure Override

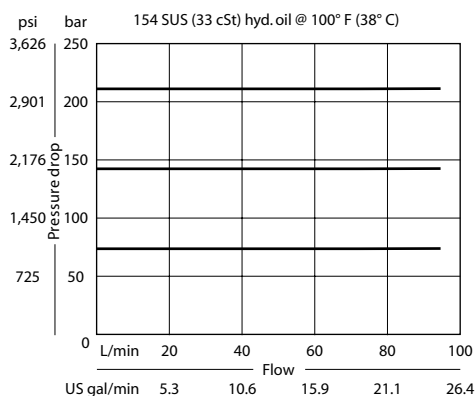

MODEL CODE

CP200 - 1 - B - 8S - A - C - 150

Seal Option

Code	Seal kit
B-Buna-N	120015
V-Viton	120016

Housing

Code	Ports & Material	Housing Model Code
0	No Housing	No Housing
DG3B	AL, 3/8 BSP	SDC10-2-DG-3B
DG4B	AL, 1/2 BSP	SDC10-2-DG-4B
6S	AL, #6 SAE	SDC10-2-6S
8S	AL, #8 SAE	SDC10-2-8S

* Aluminum bodies are to be used for pressures less than 210 bar [3000 psi].

* Additional housings available

Adjustment Option

A - Internal
E - External
F - Tamper resistant
K - Knob

Pressure Setting

Example:

Code x10 - Pressure setting in psi (50 psi increments within specified Pressure Range)	Code	Bar	Psi
150	103	[1500]	

XXX-Standard setting (see Pressure Range for value)

Pressure Range

Code	Bar	Psi
A	7-55	[100-800]
Standard Setting	28	[400]
B	17-138	[200-2000]
Standard Setting	69	[1000]
C	41-250	[600-3600]
Standard Setting	103	[1500]

Relief Valves

RV3-12

Relief Valve, Differential Area, Poppet Type

350 bar [5000 psi] • 132 l/min [35 US gpm]

DESCRIPTION AND OPERATION

This is a fast acting, differential area, poppet type relief valve that relieves from port 2 to 1. It can be used to protect an actuator from over pressurization or to remove pressure spikes.

SCHEMATIC

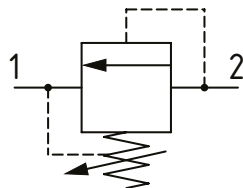

PERFORMANCE DATA

Rated pressure	350 bar [5000 psi]
Rated flow	132 l/min [35 US gpm]
Leakage	5 drops/min @ 80% of Pressure Setting
Weight	0.49 kg [1.08 lb]
Cavity	C-12-2/C-12-2U

DIMENSIONS

mm [in]

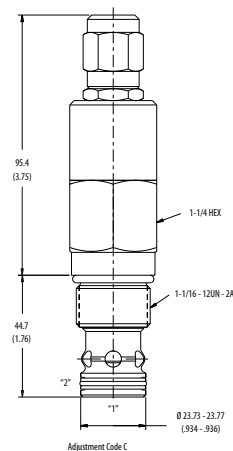

Installation Torque

A - 81-95 Nm [60-70 ft. lbs]
S - 102-115 Nm [75-85 ft. lbs]

PERFORMANCE CURVES

Pressure Override

Flow - L/min (21,8 cSt oil @ 49°F)

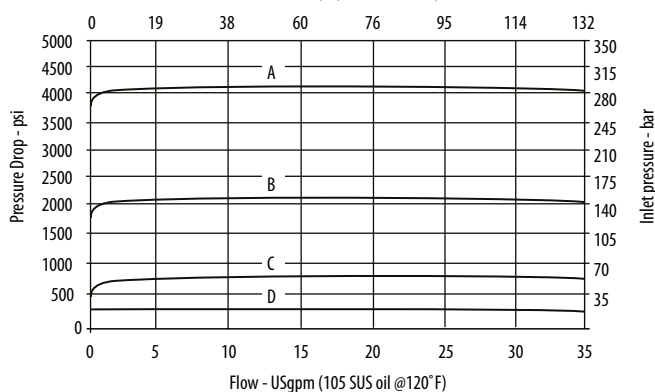

A - 40 spring • B - 22 spring • C - 8.5 spring • D - 2.5 spring

MODEL CODE

RV3 - 12 - V - C - A - 4G - U - 2.5 - 10

Seal Option

Code	Seal Kit
Omit - Buna - N	02-165889
V - Viton	02-165888

Adjustment Option

C - Tamper Resistant
F - Fixed
K - Knob
S - External

Housing Material

Omit - No Housing
A - Aluminum
S - Steel

Housing

Code	Ports	Housing Model Code			
		C-12-2 Aluminum Heavy Duty	C-12-2U Aluminum Heavy Duty	C-12-2 Steel Heavy Duty	C-12-2U Steel Heavy Duty
Omit	No Housing				
4G	1/2" BSP	02-161118	02-161116	02-172062	02-172512
6G	3/4" BSP	02-161117	02-161115	02-169665	02-162922
10T	#10 SAE	02-160640	02-160641	02-169744	02-169817
12T	#12 SAE	02-160644	02-160645	02-169782	02-169790

Pressure Range

Code x100 - Pressure setting in psi (50 psi increments within specified Pressure Range)
XXX - Standard setting (see Pressure Range for value).
Examples:

Code	Bar	Psi
10	69	[1000]
10.5	72.4	[1050]

Pressure Range

Code	Bar	Psi
2.5	3.4-17	[50-250]
Standard Setting	8.6	[125]
8.5	13-55	[200-850]
Standard Setting	29	[425]
22	20-150	[300-2200]
Standard Setting	76	[1100]
40	40-275	[600-4000]
Standard Setting	138	[2000]

Cavity

Omit - Cavity without undercut/No housing
U - Cavity with undercut

* Aluminum bodies are to be used for pressures less than 210 bar [3000 psi].

* Additional housings available

Relief Valves

CP201-1

Relief Valve, Differential Area, Poppet Type

250 bar [3600 psi] • 150 l/min [40 US gpm]

DESCRIPTION AND OPERATION

This is a fast acting, differential area, poppet type relief valve that relieves from port 2 to 1. It can be used to protect an actuator from over-pressurization or to remove pressure spikes.

SCHEMATIC

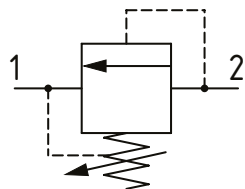

DIMENSIONS

mm [in]

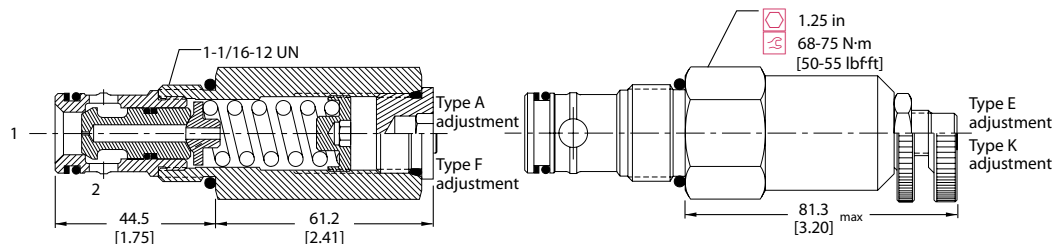

PERFORMANCE DATA

Rated pressure	250 bar [3600 psi]
Rated flow	150 l/min [40 US gpm]
Leakage	10 drops/min @ 80% of pressure setting
Weight	0.42 kg [0.92 lb]
Cavity	CP12-2

PERFORMANCE CURVES

Pressure Override

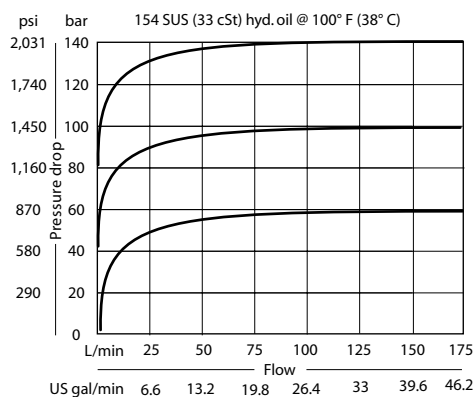

MODEL CODE

CP201 - 1 - B - 12S - A - C - 150

Seal Option

Code	Seal kit
B-Buna-N	120017
V-Viton	120018

Housing

Code	Ports & Material	Housing Model Code
0	No Housing	No Housing
4B	AL, 1/2 BSP	CP12-2-4B
6B	AL, 3/4 BSP	CP12-2-6B
10S	AL, #10 SAE	CP12-2-10S
12S	AL, #12 SAE	CP12-2-12S

* Aluminum bodies are to be used for pressures less than 210 bar [3000 psi]. * Additional housings available

Adjustment Option

A - Internal
E - External
F - Tamper resistant
K - Knob

Pressure Setting

Code x10 - Pressure setting in psi (50 psi increments within specified Pressure Range)
XXX-Standard setting (see Pressure Range for value)
Example:

Code	Bar	Psi
150	103	[1500]

Pressure Range

Code	Bar	Psi
A	7-69	[100-1000]
Standard Setting	28	[400]
B	17-172	[250-2500]
Standard Setting	69	[1000]
C	35-250	[500-3600]
Standard Setting	103	[1500]

Relief Valves

RV3-16

Relief Valve, Differential Area, Poppet Type

350 bar [5000 psi] • 300 l/min [80 US gpm]

DESCRIPTION AND OPERATION

This is a fast acting, differential area, poppet type relief valve that relieves from port 2 to 1. It can be used to protect an actuator from over-pressurization or to remove pressure spikes.

SCHEMATIC

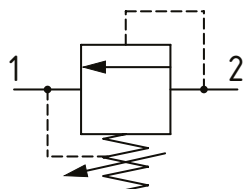

PERFORMANCE DATA

Rated pressure	350 bar [5000 psi]
Rated flow	300 l/min [80 US gpm]
Weight	0,71 kg [1.57 lbs]
Capacity	SDC16-2

MODEL CODE

RV3 - 16 - V - C - S - 6B - 5 - 10

Seal Option

Code	Seal kit
Omit-Buna-N	565810
V-Viton	889609

Adjustment Option

C - Tamper Resistant
K - Knob
S - External

Housing Material

Omit - Aluminum/No housing
S - Steel

Housing

Code	Ports	Aluminum Standard duty	Aluminum Heavy duty	Steel Heavy duty
0	No Housing			
6B	3/4" BSP	02-175463		
4G	1/2" BSP		876716	02-175106
6G	3/4" BSP		876718	02-175107
10H	#10 SAE		876717	
12H	#12 SAE		866113	
10T	#10 SAE		566113	02-175104
12T	#12 SAE	566149		02-175105

* Aluminum bodies are to be used for pressures less than 210 bar [3000 psi].

* Additional housings available

DIMENSIONS

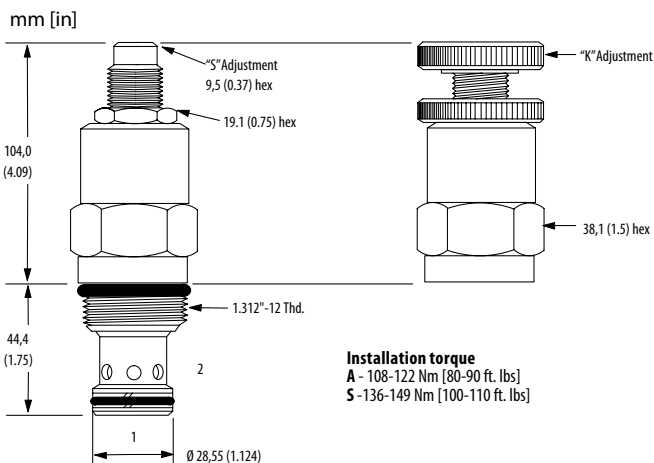

Installation torque

A - 108-122 Nm [80-90 ft. lbs]
S - 136-149 Nm [100-110 ft. lbs]

PERFORMANCE CURVES

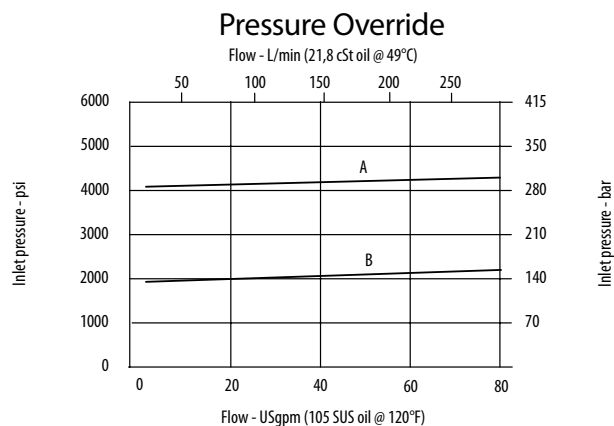

A - 50 spring • B - 35 spring

Pressure Setting

Code x10 - Pressure setting in psi (50 psi increments within specified Pressure Range)
XXX - Standard setting (see Pressure Range for value)
Example:

Code	Bar	Psi
10	70	[1000]
10.5	72.4	[1050]

Pressure Range

Code	Bar	Psi
5	3,5-35	[50-500]
Standard Setting	15,5	[225]
13	35-90	[300-1300]
Standard Setting	34,5	[500]
35	83-240	[1200-3500]
Standard Setting	79	[1150]
50	140-350	[2000-5000]
Standard Setting	103	[1500]

Relief Valves

1LR300

Relief Valve, Differential Area, Poppet Type

350 bar [5000 psi] • 380 l/min [100 US gpm]

DESCRIPTION AND OPERATION

This is a fast acting, differential area, poppet type relief valve that relieves from port 2 to 1. It can be used to protect an actuator from over-pressurization or to remove pressure spikes.

SCHEMATIC

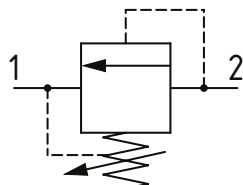

PERFORMANCE DATA

Rated pressure	350 bar [5000 psi]
Rated flow	380 l/min [100 US gpm]
Leakage	1 ml/min nominal [15 drops/min]
Weight	1.04 kg [2.3 lb]
Cavity	A1126

MODEL CODE

1LR300 - F - 10W - 20 - S - 377 - 60

Basic Code

1LR300 - No Housing
1LR350 - Cartridge and housing

Adjustment Option

F - External

Housing

Code	Ports	Housing Model Code	
		Aluminum	Steel
Omit	No Housing		
10W	1 1/4" BSP	B5134	B882
20T	1 1/4" SAE	B7783	B11553

* Aluminum bodies are to be used for pressures less than 210 bar [3000 psi].

* Additional housings available

Pressure Setting

Code - Pressure setting in bar (5 bar increments within specified Pressure Range)

XXX - Standard setting (see Pressure Range for value)
Example:

Code	Bar	Psi
60	60	[870]

Housing Material

Omit - Aluminum/No housing
377 - Steel

Seal Option

Code	Seal Kit
S	Nitrile SK207
SV	Viton SK207V

Pressure Range

Code	Bar	Psi
20	35-210	[508-3000]
Standard Setting	100	[1015]
35	70-350	[102-5000]
Standard Setting	280	[4060]

Pressure setting made at 30 l/min

DIMENSIONS

mm [in]

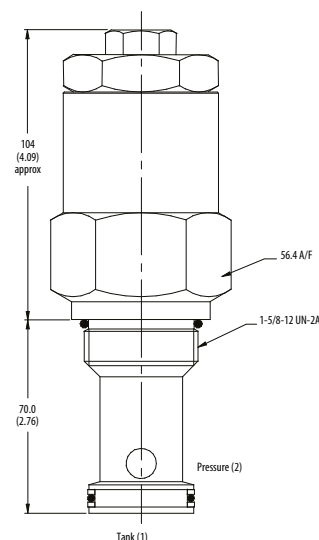

Installation Torque
150 Nm [110 ft. lbs]

PERFORMANCE CURVES

Pressure Override

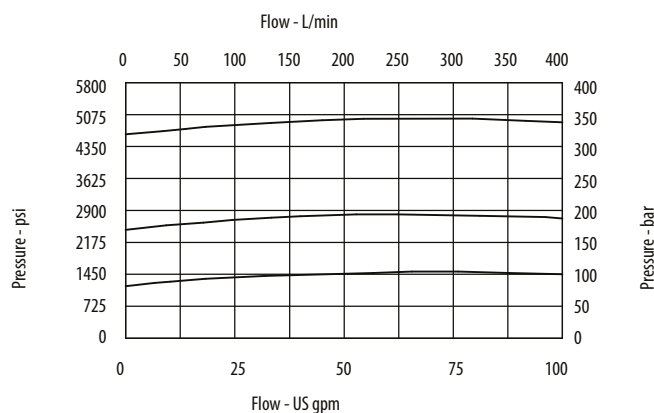

Relief Valves

RV5-10

Relief valve, Pilot operated, Spool Type

350 bar [5000 psi] • 114 l/min [30 US gpm]

DESCRIPTION AND OPERATION

This is a pilot operated, spool type relief valve that relieves from port 1 to port 2. It can be used to limit pressure in a system while maintaining accurate pressure control with constant or varying flows.

SCHEMATIC

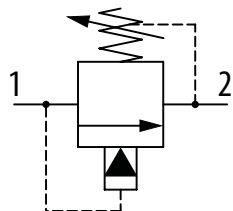

PERFORMANCE DATA

Rated pressure	350 bar [5000 psi]
Rated flow	114 l/min [30 US gpm]
Leakage	114 ml/min [7 ln ³ /min] @ 350 bar [5000 psi]
Weight	0.22 kg [0.48 lb]
Cavity	SDC10-2

MODEL CODE

RV5 - A - 10 - V - C - S - 2G - 20 - 10

Seal Configuration

Omit - Single back-up ring as shown
A - 1/2 thickness back-up ring on each side of o-ring (for cross port relief applications)

Seal Option

Code	Seal kit
Omit -Buna - N	565803
V -Viton	565806

Adjustment Option

C - Tamper Resistant
F - Fixed
I - Internal
K - Knob
S - External

Housing Material

Omit - Aluminum/No housing
S - Steel

Housing

Code	Ports	Housing Model Code		
		Aluminum Standard Duty	Aluminum Heavy Duty	Steel Heavy Duty
0	No Housing			
3B	3/8" BSP	02-175462	-	-
2G	1/4" BSP	-	876702	02-175102
3G	3/8" BSP	-	876703	02-175103
6H	#6 SAE	-	876700	-
8H	#8 SAE	-	876701	-
6T	#6 SAE	566151	-	02-175100
8T	#8 SAE	-	-	02-175101

Pressure Setting

Code x100 - Pressure setting in psi (50 psi increments within specified Pressure Range)
XXX-Standard setting (see Pressure Range for value)
 Examples:

Code	Bar	Psi
10	6.9	[1000]
10.5	7.24	[1050]

Pressure Range

Code	Bar	Psi
3	3.4-20	[50-300]
Standard Setting	10.3	[150]
20	7-140	[100-2000]
Standard Setting	69	[1000]
35	17-240	[250-3500]
Standard Setting	121	[1750]
50	35-350	[500-5000]
Standard Setting	172	[2500]

DIMENSIONS

mm [in]

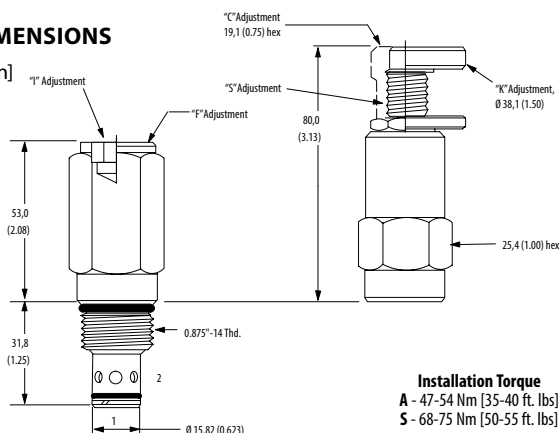

Installation Torque

A - 47-54 Nm [35-40 ft. lbs]
S - 68-75 Nm [50-55 ft. lbs]

PERFORMANCE CURVES

Pressure Override

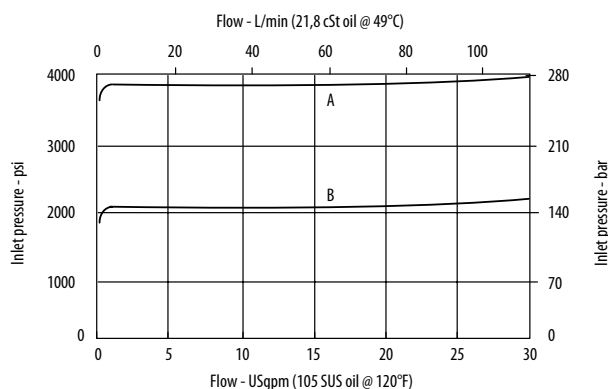

A - 50 spring • **B** - 20 spring

Relief Valves

RV11-12

Relief valve, Pilot operated, Spool Type

350 bar [5000 psi] • 190 l/min [50 US gpm]

DESCRIPTION AND OPERATION

This is a pilot operated, spool type relief valve that relieves from port 1 to port 2. It can be used to limit pressure in a system while maintaining accurate pressure control with constant or varying flows.

SCHEMATIC

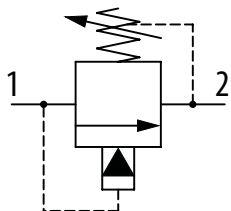

DIMENSIONS

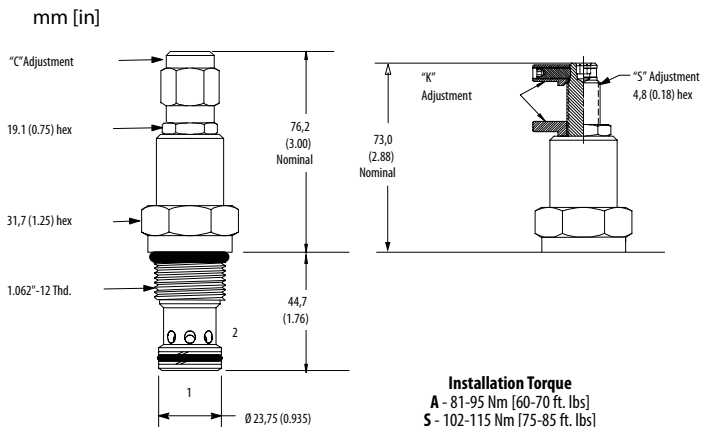

PERFORMANCE DATA

Rated pressure	350 bar [5000 psi]
Rated flow	190 l/min [50 US gpm]
Leakage	131 ml/min [8 in3/min] @ 350 bar [5000 psi]
Weight	0.3 kg [0.68 lb]
Cavity	C-12-2 / C-12-2U

PERFORMANCE CURVES

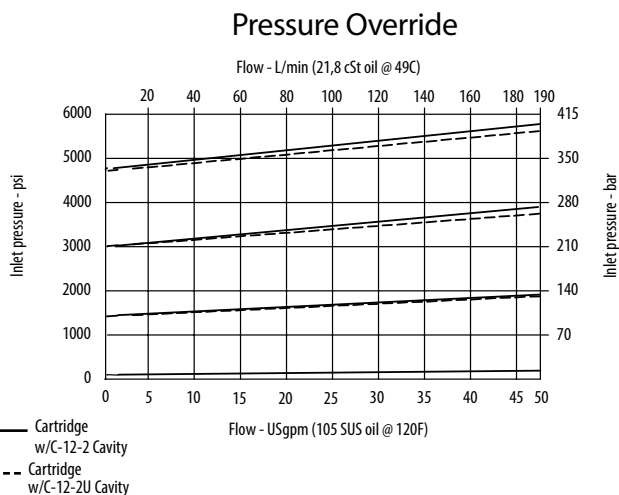

MODEL CODE

RV11 - 12 - V - S - A - 4G - U - 15 - 10

Seal Option

Code	Seal Kit
Omit-Buna - N	02-165889
V-Viton	02-165888

Adjustment Option

S - External
 C - Tamper Resistant
 K - Knob

Housing Material

Omit - No Housing
 A - Aluminum
 S - Steel

Housing

Code	Ports	Housing Model Code			
		C-12-2 Aluminum Heavy Duty	C-12-2U Aluminum Heavy Duty	C-12-2 Steel Heavy Duty	C-12-2U Steel Heavy Duty
0	No Housing				
10T	#10 SAE	02-160640	02-160641	02-169744	02-169817
12T	#12 SAE	02-160644	02-160645	02-169782	02-169790
4G	1/2" BSP	02-161118	02-161116	02-172062	02-172512
6G	3/4" BSP	02-161117	02-161115	02-169665	02-169922

* Aluminum bodies are to be used for pressures less than 210 bar [3000 psi].

* Additional housings available

Pressure Setting

Code x100 - Pressure setting in psi (50 psi increments within specified Pressure Range)
 XXX-Standard setting (see Pressure Range for value)
 Examples:

Code	Bar	Psi
10	69	[1000]
10.5	72.4	[1050]

Pressure Range

Code	Bar	Psi
15	10.3-103	[150-1500]
Standard Setting	52	[750]
30	17-210	[250-3000]
Standard Setting	103	[1500]
50	24-350	[350-5000]
Standard Setting	172	[2500]

Cavity

Omit - Cavity without undercut/No housing
 U - Cavity with undercut

Relief Valves

1AR100

Relief valve, Pilot operated, Spool Type

400 bar [5800 psi] • 150 l/min [40 US gpm]

DESCRIPTION AND OPERATION

This is a pilot operated, spool type relief valve that relieves from port 1 to port 2. It can be used to limit pressure in a system while maintaining accurate pressure control with constant or varying flows.

SCHEMATIC

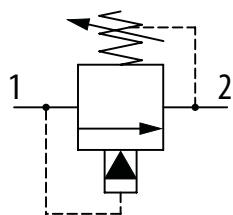

PERFORMANCE DATA

Rated pressure	400 bar [5800 psi]
Rated flow	150 l/min [40 US gpm]
Leakage	20 to 65 ml/min nominal
Weight	0.14 kg [0.3 lb]
Cavity	A881

MODEL CODE

1AR100 - P - 3W - 7 - S - 377 - 60

Basic Code

1AR100 - No Housing
1AR145 - Cartridge and housing
1AR150/1AR155 - Cartridge and housing
Through ported

Adjustment Option

P - External
R - Knob
G - Tamper resistant

Housing

Code	Ports	Housing Model Code				
		Aluminum 1AR145	Aluminum 1AR150	Steel 1AR150	Aluminum 1AR155	Steel 1AR155
Omit	No Housing					
3W	3/8" BSP		C1084			
4W	1/2" BSP	B4851	C1044	C593		
6W	3/4" BSP	B3954	C1086	C4917		
8W	1" BSP				B1617	B4596
6T	3/8" SAE		B10784			
8T	1/2" SAE	B19403	C7140			
12T	3/4" SAE	B19404	B10506	B10742		
16T	1" SAE				B1037	B24040

Pressure Setting

Code-Pressure setting in bar
(5 bar increments within
specified Pressure Range)
XXX-Standard setting
(see Pressure Range for value)
Example:

Code	Bar	Psi
60	60	[870]

Housing Material

Omit - Aluminum/No housing
377 - Steel

Seal Option

Code	Seal Kit
S-Nitrile	SK164
SV-Viton	SK164V

Pressure Range

Code	Bar	Psi
7	10-70	[145-1015]
Standard Setting	35	[510]
20	10-210	[145-3000]
Standard Setting	100	[1450]
40	50-400	[725-5800]
Standard Setting	280	[4060]

* Aluminum bodies are to be used for pressures less than 210 bar [3000 psi].

* Additional housings available

DIMENSIONS

mm [in]

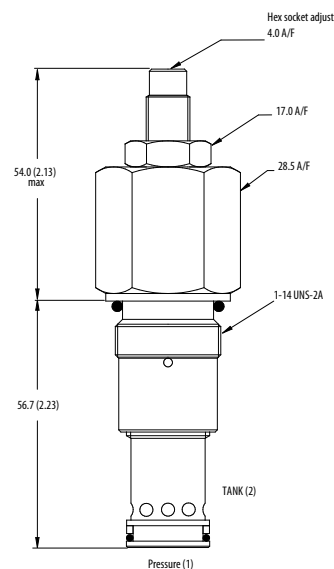

Installation Torque:
60 Nm [44 ft. lbs]

PERFORMANCE CURVES

Pressure Override

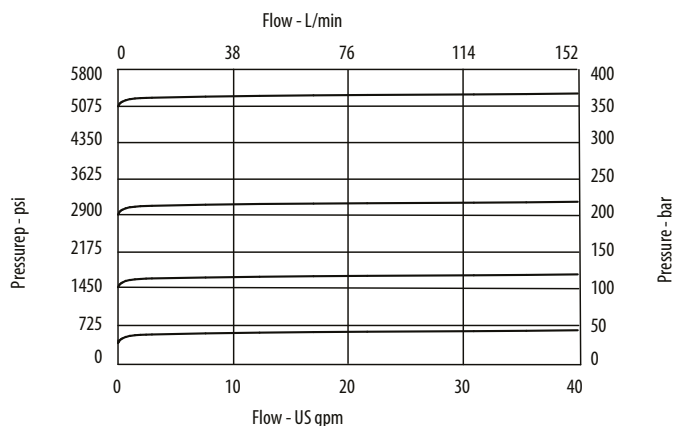

Relief Valves

RV5-16

Relief valve, Pilot operated, Spool Type

350 bar [5000 psi] • 300 l/min [80 US gpm]

DESCRIPTION AND OPERATION

This is a pilot operated, spool type relief valve that relieves from port 1 to port 2. It can be used to limit pressure in a system while maintaining accurate pressure control with constant or varying flows.

SCHEMATIC

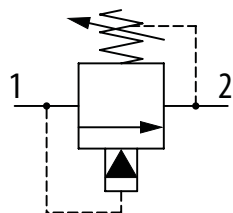

PERFORMANCE DATA

Rated pressure	350 bar [5000 psi]
Rated flow	300 l/min [80 US gpm]
Leakage	164 ml/min [10 ln ³ /min] @ 350 bar [5000 psi]
Weight	0.71 kg [1.57 lb]
Cavity	SDC16-2

DIMENSIONS

mm [in]

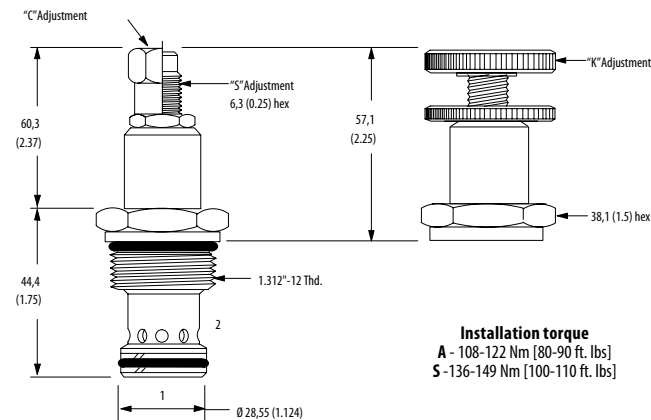

Installation torque
A - 108-122 Nm [80-90 ft. lbs]
S - 136-149 Nm [100-110 ft. lbs]

PERFORMANCE CURVES

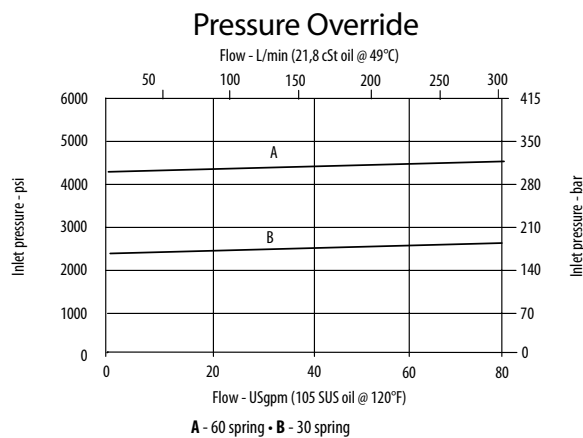

MODEL CODE

RV5 - 16 - V - S - S - 4G - 30 - 10

Seal Option

Code	Seal Kit
Omit - Buna - N	889631
V - Viton	889635

Adjustment Option

S - External
 C - Tamper Resistant
 K - Knob

Housing Material

Omit - Aluminum/No housing
 S - Steel

Housing

Code	Ports	Housing Model Code		
		Aluminum Standard Duty	Aluminum Heavy Duty	Steel Heavy Duty
0	No Housing			
6B	3/4" BSP	02-175463	-	-
4G	1/2" BSP	-	876716	02-175106
6G	3/4" BSP	-	876718	02-175107
10H	#10 SAE	-	876717	-
12H	#12 SAE	-	566113	-
10T	#10 SAE	-	-	02-175104
12T	#12 SAE	566149	-	02-175105

Pressure Setting

Code x100 - Pressure setting in psi (50 psi increments within specified Pressure Range)

XXX - Standard setting (see Pressure Range for value)
 Examples:

Code	Bar	Psi
10	69	[1000]
10.5	72.4	[1050]

Pressure Range

Code	Bar	Psi
30	34-210	[500-3000]
Standard Setting	103	[1500]
60	69-415	[1000-6000]
Standard Setting	210	[3000]

* Aluminum bodies are to be used for pressures less than 210 bar [3000 psi].

* Additional housings available

Relief Valves

1ARD100

Relief Valve, Pilot operated, Spool Type, Anti-Shock

210 bar [3000 psi] • 100 l/min [26 US gpm]

DESCRIPTION AND OPERATION

This is a pilot operated relief valve designed to remove pressure spikes in a system by providing dampening on initial opening. System pressure acts on the pilot section of the valve, and when the setting is reached pilot flow passes through the center of the dampening piston and through an orifice to tank. The flow through the orifice causes the dampening piston to compress the main spring to increase the setting. The level of dampening is determined by the distance moved by the dampening piston. The amount of dampening can be adjusted clockwise to reduce the amount of dampening.

SCHEMATIC

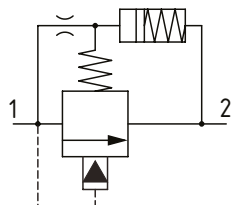

PERFORMANCE DATA

Rated pressure	210 bar [3000 psi]
Rated flow	100 l/min [26 US gpm]
Leakage	100 ml/min nominal
Weight	0.41 kg [0.9 lb]
Cavity	A881

MODEL CODE

1ARD100 - N - 4W - 20 - S - 377 - 60

Basic Code

1ARD100 - No housing
 1ARD145 - Cartridge and housing
 1ARD150/1ARD155 - Cartridge and housing through ported

Adjustment Option

N - Non-adjustable
 *Valve is pre-set at the factory to a specific pressure setting. Only the level of dampening can be adjusted.

Housing

Code	Ports	Housing Model Code				
		Aluminum 1ARD145	Aluminum 1ARD150	Steel 1ARD150	Aluminum 1ARD155	Steel 1ARD155
Omit	No Housing					
3W	3/8" BSP		C1084			
4W	1/2" BSP	B4851	C1044	C593		
6W	3/4" BSP	B3954	C1086	C4917		
8W	1" BSP				B1617	B4596
6T	3/8" SAE		B10784			
8T	1/2" SAE	B19403	C7140			
12T	3/4" SAE	B19404	B10506	B10742		
16T	1" SAE				B1037	B24040

Pressure Setting

Code - Pressure setting in bar (10 bar increments within specified Pressure Range)
 Example:

Code	Bar	Psi
60	60	[870]

Housing Material

Omit - Aluminum/No housing
 377 - Steel

Seal Option

Code	Seal Kit
S-Buna-N	SK1412
SV-Viton	SK1412V

Pressure Range

Code	Bar	Psi
7	10-70	[145-1015]
20	10-210	[145-3000]

Setting fixed with +/- 10 bar tolerance at 10 l/min

DIMENSIONS

mm [in]

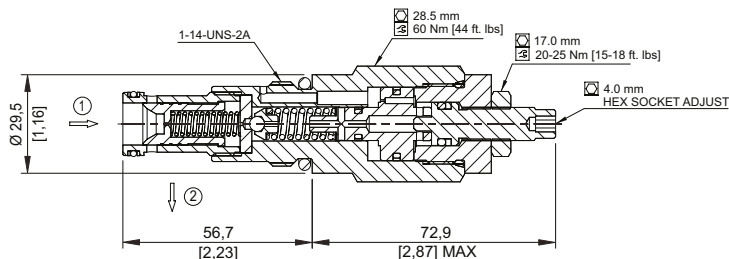

Installation torque
 60 Nm [44 ft. lbs]

PERFORMANCE CURVES

Typical Dampening

160 bar pressure setting

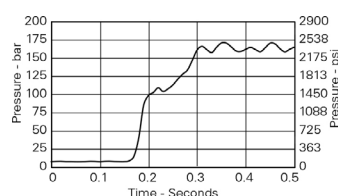

Pressure Override

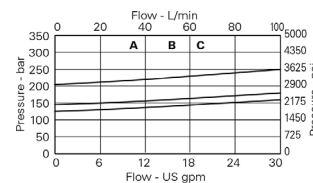

Relief Valves

RV2-10

Relief valve, Pilot Operated, Spool Type with Reverse Free Flow
350 bar [5000 psi] • 114 l/min [30 US gpm]

DESCRIPTION AND OPERATION

This is a pilot operated, spool type relief valve that relieves from port 1 to port 2 with an integrated reverse flow check valve from port 2 to 1. It can be used to limit pressure in a system or on the work port of a directional valve. It maintains accurate pressure control with constant or varying flows, while also allowing make up flow through in the reverse direction.

SCHEMATIC

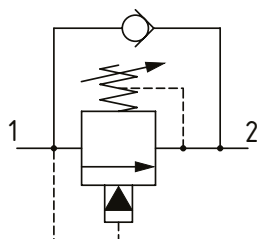

PERFORMANCE DATA

Rated pressure	350 bar [5000 psi]
Rated flow	114 l/min [30 US gpm]
Leakage	0.3 ml/min [5 drops/min] @ 85% of Pressure Setting
Weight	0.22 kg [0.48 lb]
Cavity	SDC10-2

MODEL CODE

RV2 - 10 - V - C - S - 2G - 20 - 10

Seal Option

Code	Seal Kit
Omit - Buna - N	565803
V - Viton	566086

Adjustment Option

C - Tamper Resistant
 F - Fixed
 I - Internal
 K - Knob
 S - External

Housing Material

Omit - Aluminum/No housing
 S - Steel

Housing

Code	Ports	Housing Model Code		
		Aluminum Standard Duty	Aluminum Heavy Duty	Steel Heavy Duty
0	No Housing			
3B	3/8" BSP	02-175462	-	-
2G	1/4" BSP	-	876702	02-175102
3G	3/8" BSP	-	876703	02-175103
6H	#6 SAE	-	876700	-
8H	#8 SAE	-	876701	-
6T	#6 SAE	566151	-	02-175100
8T	#8 SAE	-	-	02-175101

* Aluminum bodies are to be used for pressures less than 210 bar [3000 psi].

* Additional housings available

DIMENSIONS

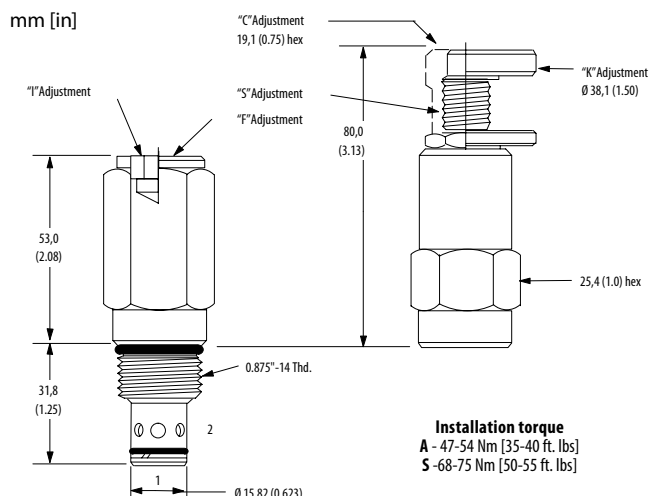

Installation torque
 A - 47-54 Nm [35-40 ft. lbs]
 S - 68-75 Nm [50-55 ft. lbs]

PERFORMANCE CURVES

Pressure Override

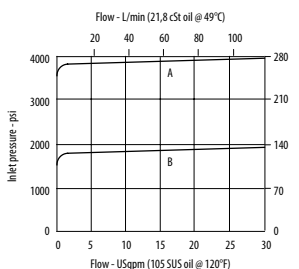

A - 50 spring - B - 20 spring

Pressure Drop for reverse flow cartridge only

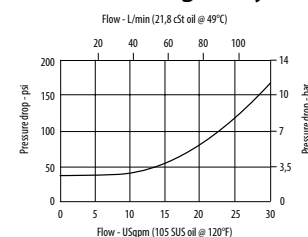

Pressure Range

Code	Bar	Psi
3	3.5-20	[50-300]
Standard Setting	10.3	[150]
20	7-140	[100-2000]
Standard Setting	69	[1000]
35	17-240	[250-3500]
Standard Setting	121	[1750]
50	35-350	[500-5000]
Standard Setting	172	[2500]

Relief Valves

RV10-POP

Relief valve, Pilot Operated, Spool Type with Reverse Free Flow

250 bar [3600 psi] • 120 l/min [32 US gpm]

DESCRIPTION AND OPERATION

This is a pilot operated, poppet type relief valve that relieves from port 1 to port 2 with an integrated reverse flow check valve from port 2 to 1. Due to its unique poppet design, this valve offers faster response than a typical pilot operated valve. It can be used to limit pressure in a system or on a service line of a directional valve. It maintains accurate pressure control with constant or varying flows, while also allowing make up flow through in the reverse direction.

SCHEMATIC

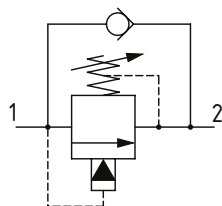

DIMENSIONS

mm [in]

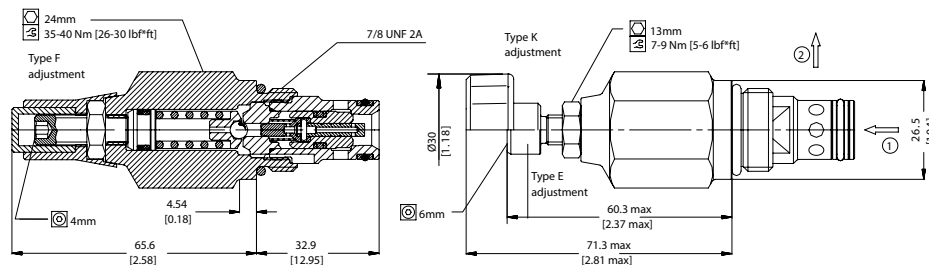

PERFORMANCE DATA

Rated pressure	250 bar [3600 psi]
Rated flow	120 l/min [32 US gpm]
Leakage	6 drops/min @ 80% of pressure setting
Weight	0.22 kg [0.49 lb]
Cavity	SDC10-2

PERFORMANCE CURVES

Pressure Override

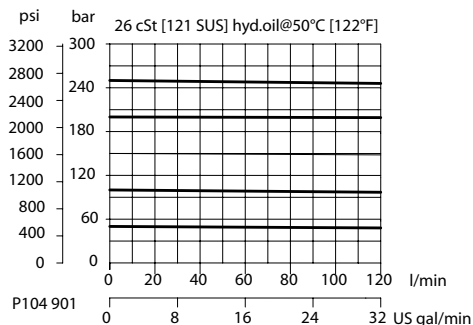

MODEL CODE

RV10 - POP - 3 - E - 100 - B - 00

Pressure Range

Code	Bar	Psi
3	25-250	[360-3600]

Standard Setting Not set

Adjustment Option

E - External
F - Tamper Resistant
K - Knob

Pressure Setting

Example:

Code	Bar	Psi
100	100	[1450]

Code - Pressure setting in bar (5 bar increments within specified Pressure Range)
XXX - Standard setting (see Pressure Range for value)

Housing

Code	Ports & Material	Housing Model Code
Omit	No Housing	No Housing
6S	Al, #6 SAE	CP10-2-6S
8S	Al, #8 SAE	CP10-2-8S
DG3B	Al, 3/8 BSP	DC10-2-DG3B
DG4B	Al, 1/2 BSP	DC10-2-DG4B

* Aluminum bodies are to be used for pressures less than 210 bar [3000 psi].

* Additional housings available

Seal Option

Code	Seal kit
B - Buna - N	354004019
V - Viton	354003419

Relief Valves

1ARC100

Relief valve, Pilot Operated, Spool Type with Reverse Free Flow

400 bar [5800 psi] • 150 l/min [40 US gpm]

DESCRIPTION AND OPERATION

This is a pilot operated, spool type relief valve that relieves from port 1 to port 2 with an integrated reverse flow check valve from port 2 to 1. It can be used to limit pressure in a system or on a service line of a directional valve. It maintains accurate pressure control with constant or varying flows, while also allowing make up flow through in the reverse direction.

SCHEMATIC

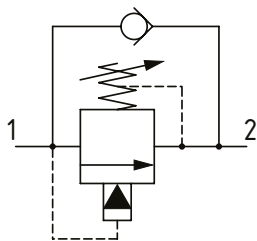

PERFORMANCE DATA

Rated pressure	400 bar [5800 psi]
Rated flow	150 l/min [40 US gpm]
Leakage	125 ml/min @ 280 bar [4060 psi]
Weight	0.14 kg [0.3 lb]
Cavity	A881

DIMENSIONS

mm [in]

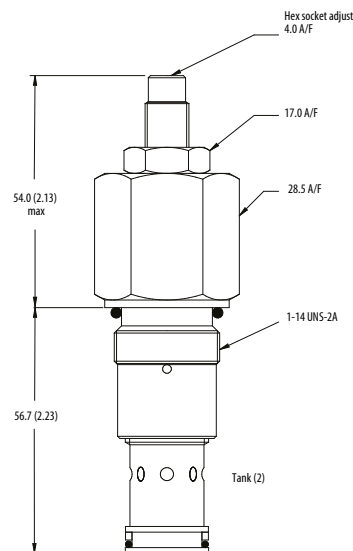

Installation torque
60 Nm [44 ft. lbs]

PERFORMANCE CURVES

Pressure Drop

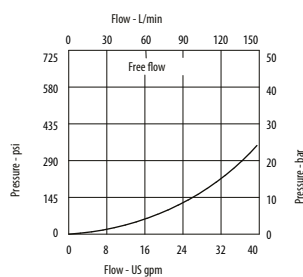

Pressure Override

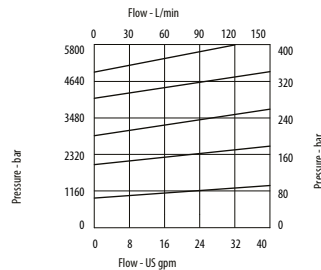

MODEL CODE

1ARC100 - P - 3W - 40 - S - 377 - 60

Basic Code

1ARC100 - No Housing
1ARC145 - Cartridge and housing
1ARC150/1ARC155 - Cartridge and housing through ported

Adjustment Option

P - External
R - Knob
G - Tamper resistant

Housing

Code	Ports	Housing Model Code				
		Aluminum 1ARC145	Aluminum 1ARC150	Steel 1ARC150	Aluminum 1ARC155	Steel 1ARC155
Omit	No Housing					
3W	3/8" BSP		C1084			
4W	1/2" BSP	B4851	C1044	C593		
6W	3/4" BSP	B3954	C1086	C4917		
8W	1" BSP				B1617	B4596
6T	3/8" SAE		B10784			
8T	1/2" SAE	B19403	C7140			
12T	3/4" SAE	B19404	B10506	B10742		
16T	1" SAE				B1037	B24040

Pressure Setting

Code - Pressure setting in bar
(5 bar increments within
specified Pressure Range)
XXX - Standard setting
(see Pressure Range for value)
Example:

Code	Bar	Psi
60	60	[870]

Housing Material

Omit - Aluminum/No housing
377 - Steel

Seal Option

Code	Seal Kit
S	Nitrile SK164
SV	Viton SK164V

Pressure Range

Code	Bar	Psi
7	10-70	[145-1015]
Standard Setting	35	[510]
20	10-210	[145-3000]
Standard Setting	100	[1450]
40	50-400	[725-5800]
Standard Setting	280	[4060]

Pressure setting made at 14 l/min

* Aluminum bodies are to be used for pressures less than 210 bar [3000 psi].

* Additional housings available

Relief Valves

1VR100

Relief Valve, Pilot Operated, Spool Type, Ventable

350 bar [5000 psi] • 100 l/min [26 US gpm]

DESCRIPTION AND OPERATION

This is a pilot operated, spool type relief valve that relieves from port 1 to port 2 with a vent port 3. Using pilot control valves on the vent line, it can be used as a dump valve, in two pressure systems or as the main section of a proportional control valve while maintaining a maximum relief pressure.

SCHEMATIC

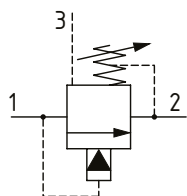

DIMENSIONS

mm [in]

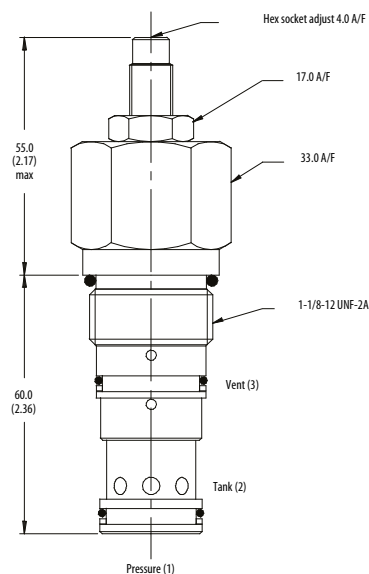

Installation torque

75 Nm [55 ft. lbs]

PERFORMANCE DATA

Rated pressure	350 bar [5000 psi]
Rated flow	100 l/min [26 US gpm]
Leakage	35 ml/min @ 280 bar [4060 psi]
Weight	0.46 kg [1.0 lb]
Cavity	A3146

PERFORMANCE CURVES

Pressure Override

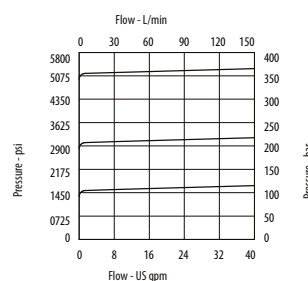

Pressure Drop

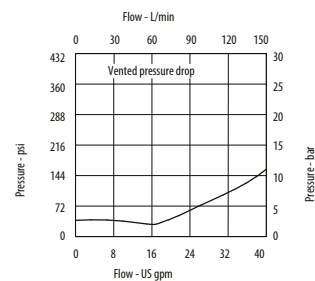

MODEL CODE

1VR100 - P - 8W - 35 - S - 377 - 60

Basic Code

1VR100 - No housing
1VR150 - Cartridge and housing

Adjustment Option

P - External
G - Tamper resistant

Housing

Code	Ports	Housing Model Code	
		Aluminum	Steel
Omit	No Housing		
6W	3/4" BSP	B4377	B4378
12T	3/4" SAE	B10785	B11554

* Aluminum bodies are to be used for pressures less than 210 bar [3000 psi].
* Additional housings available

Housing Material

Omit - Aluminum/No housing
377 - Steel

Seal Option

Code	Seal Kit
S-Nitrile	SK275
SV-Viton	SK275V

Pressure Range

Code	Bar	Psi
20	10-210	[145-3000]
Standard Setting	100	[1450]
35	30-350	[435-5000]
Standard Setting	210	[3000]

Pressure setting made at 14 l/min

Pressure Setting

Code - Pressure setting in bar (5 bar increments within specified Pressure Range)
XXX-Standard setting (see Pressure Range for value)
Example:

Code	Bar	Psi
60	60	[870]

Relief Valves

1VR200

Relief Valve, Pilot Operated, Spool Type, Ventable

350 bar [5000 psi] • 200 l/min [52 US gpm]

DESCRIPTION AND OPERATION

This is a pilot operated, spool type relief valve that relieves from port 1 to port 2 with a vent port 3. Using pilot control valves on the vent line, it can be used as a dump valve, in two pressure systems or as the main section of a proportional control valve while maintaining a maximum relief pressure.

SCHEMATIC

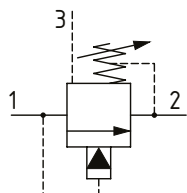

PERFORMANCE DATA

Rated pressure	350 bar [5000 psi]
Rated flow	200 l/min [52 US gpm]
Leakage	35 ml/min @ 280 bar [4060 psi]
Weight	0.74 kg [1.6 lb]
Cavity	A16102

DIMENSIONS

mm [in]

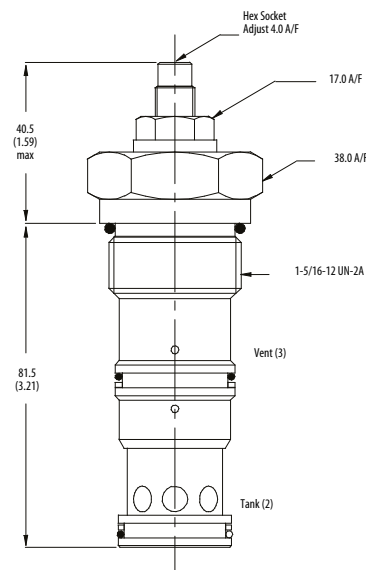

Installation torque
100 Nm [73 ft. lbs]

PERFORMANCE CURVES

Pressure Override

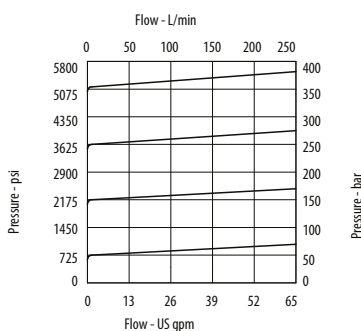

Pressure Drop

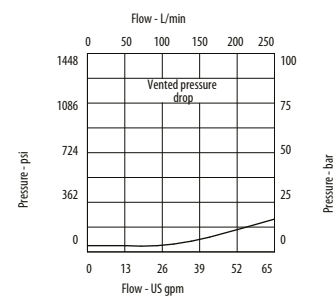

MODEL CODE

1VR200 - P - 6W - 35 - S - 377 - 75

Basic Code

1VR200 - No Housing
1VR250 - Cartridge and housing

Adjustment Option

P - External
G - Tamper resistant

Housing

Code	Ports	Housing Model Code	
		Aluminum	Steel
Omit No Housing			
8W	1" BSP	B3496	B3497
16T	1" SAE	B6807	B11555

* Aluminum bodies are to be used for pressures less than 210 bar [3000 psi].

* Additional housings available

Housing Material

Omit - Aluminum/No housing
377 - Steel

Seal Option

Code	Seal Kit
S -Nitrile	SK173
SV -Viton	SK173V

Pressure Setting

Code - Pressure setting in bar (5 bar increments within specified Pressure Range)
XXX - Standard setting (see Pressure Range for value)
Example:

Code	Bar	Psi
75	75	[1190]

Pressure Range

Code	Bar	Psi
20	10-210	[145-3000]
Standard Setting	100	[1450]
35	30-350	[435-5000]
Standard Setting	210	[3000]

Pressure setting made at 14 l/min

Relief Valves

CP200-7

Relief Valve, Differential Area, Poppet Type, Bi-directional

250 bar [3600 psi] • 40 l/min [11 US gpm]

DESCRIPTION AND OPERATION

This is a bi-directional relief valve that relieves from port 1 to 2 and from port 2 to 1. It is ideal as a cross port relief valve protection for motor applications.

SCHEMATIC

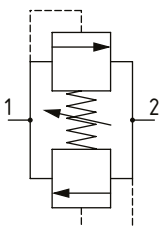

DIMENSIONS

mm [in]

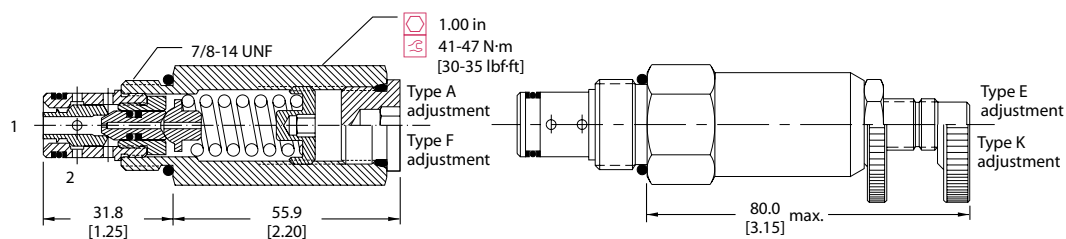

PERFORMANCE DATA

Rated pressure	250 bar [3600 psi]
Rated flow	40 l/min [11 US gpm]
Leakage	5 ml/min [0.3 l ³ /min] @ 80% of pressure setting
Weight	0.20 kg [0.43 lb]
Cavity	SDC10-2

PERFORMANCE CURVES

Pressure Override

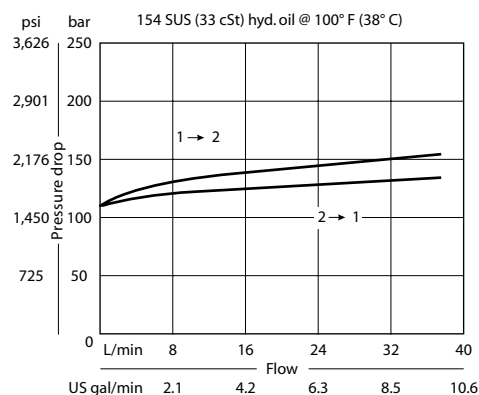

MODEL CODE

CP200 - 7 - B - 8S - A - C - 150

Seal Option

Code	Seal kit
B -Buna-N	120073
V -Viton	120074

Housing

Code	Ports & Material	Housing Model Code
0	No Housing	No Housing
DG3B	AL, 3/8 BSP	SDC10-2-DG-3B
DG4B	AL, 1/2 BSP	SDC10-2-DG-4B
6S	AL, #6 SAE	CP10-2-6S
8S	AL, #8 SAE	CP10-2-8S

* Aluminum bodies are to be used for pressures less than 210 bar [3000 psi].

* Additional housings available

Adjustment Option

A - Internal
E - External
F - Tamper resistant
K - Knob

Pressure Setting

Code x10 - Pressure setting in psi
(50 psi increments within specified Pressure Range)
XXX - Standard setting (see Pressure Range for value)
Example:

Code	Bar	Psi
150	103	[1500]

Pressure Range

Code	Bar	Psi
A	7-41	[100-600]
Standard Setting	28	[400]
B	17-97	[250-1400]
Standard Setting	69	[1000]
C	41-250	[600-3600]
Standard Setting	103	[1500]

Relief Valves

1CLLR100

Relief Valve, Differential Area, Poppet Type, Bi-directional
350 bar [5000 psi] • 150 l/min [40 US gpm]

DESCRIPTION AND OPERATION

This is a bi-directional relief valve that relieves from port 1 to 2 and from port 2 to 1. It is ideal as a cross port relief valve protection for motor applications.

SCHEMATIC

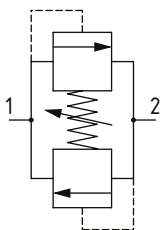

PERFORMANCE DATA

Rated pressure	350 bar [5000 psi]
Rated flow	150 l/min [40 US gpm]
Leakage	5 ml/min nominal
Weight	0.23 kg [0.5 lb]
Cavity	A878

MODEL CODE

1CLLR100 - F - 6W - 35 - S - 377 - 210

Basic code

1CLLR100 - No Housing
1CLLR150 - Cartridge and housing
1CLLR155 - Cartridge and housing (through ported)

Adjustment Option

F - External

Housing

Code	Ports	Housing Model Code			
		Aluminum 1CLLR150	Steel 1CLLR150	Aluminum 1CLLR155	Steel 1CLLR155
Omit	No Housing				
6W	3/4" BSP	B1067	B5614	B2216	B7147
8W	1" BSP	B1069	B542		
12T	3/4" SAE	B4409		B10623	
16T	1" SAE	B10827	B11801		

* Aluminum bodies are to be used for pressures less than 210 bar [3000 psi].

* Additional housings available

Pressure Setting

Code - Pressure setting in bar (5 bar increments within specified Pressure Range)
XXX - Standard setting (see Pressure Range for value)
 Example:

Code	Bar	Psi
210	210	[3000]

Housing Material

Omit - Aluminum/No housing
377 - Steel

Seal Option

Code	Seal Kit
S - Nitrile	SK614
SV - Viton	SK614V

Pressure Range

Code	Bar	Psi
20	50-210	725-3000
Standard Setting	140	[2030]
35	114-350	[1650-5000]
Standard Setting	280	[4060]

Pressure setting made at 14 l/min

DIMENSIONS

mm [in]

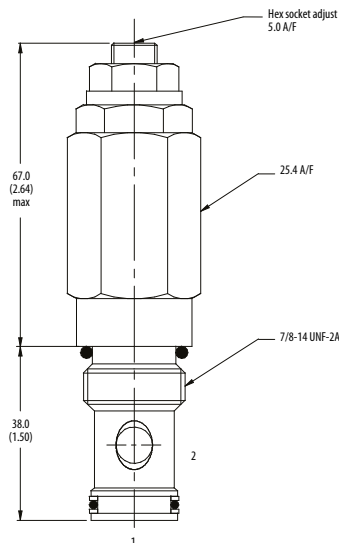

Installation torque
 60 Nm [44 ft. lbs]

PERFORMANCE CURVES

Pressure Override

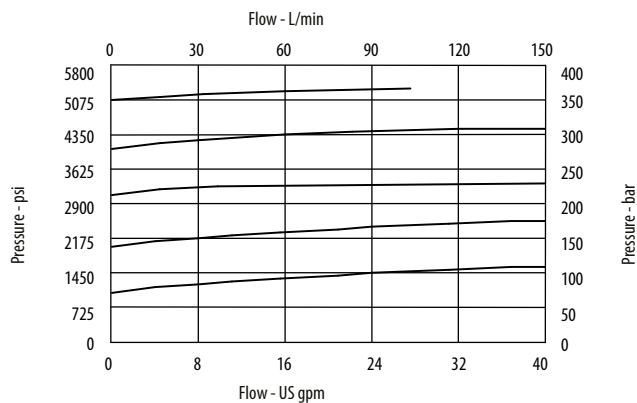

Relief Valves

CP220-1

Cross-Over Relief Valve, Line Mounted

250 bar [3600 psi] • 76 l/min [20 US gpm]

DESCRIPTION AND OPERATION

This valve is an inline cross relief. It uses two CP200-1 differential area relief valves.

SCHEMATIC

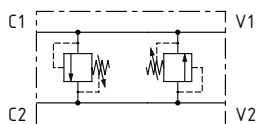

DIMENSIONS

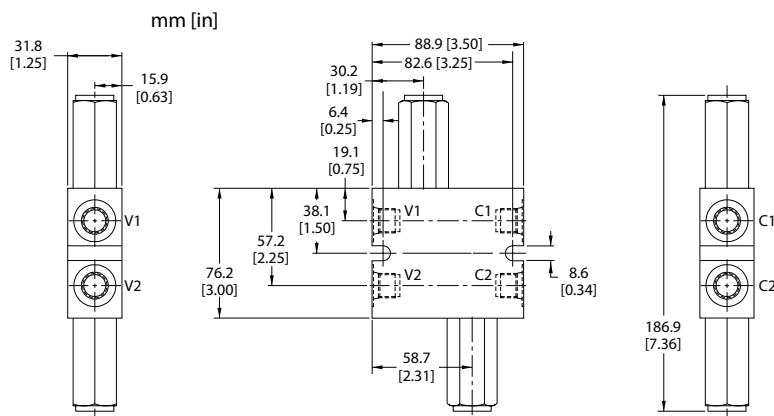

PERFORMANCE DATA

Rated pressure	250 bar [3600 psi]
Rated flow	76 l/min [20 US gpm]
Weight	0.82 kg [1.80 lb]

PERFORMANCE CURVES

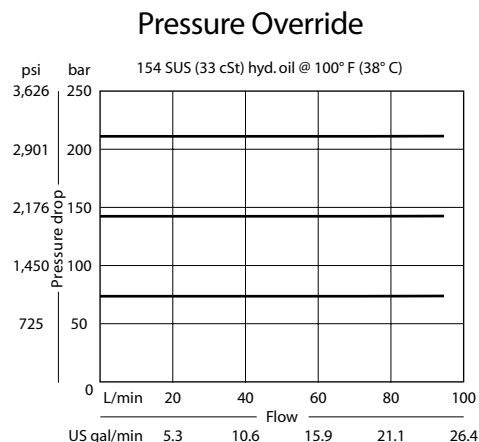

MODEL CODE

CP220 - 1 - 8S - B - 0 - A - C - 150

Housing

Code	Ports & Material	Housing Model Code
3B	AL, 3/8 BSP	221743
4B	AL, 1/2 BSP	221744
6S	AL, #6 SAE	220216
8S	AL, #8 SAE	220217

* Aluminum bodies are to be used for pressures less than 210 bar [3000 psi].

* Additional housings available

Seal Option

Code	Seal kit
B-Buna-N	120072
V-Viton	120161

Adjustment Option

A - Internal
E - External
F - Tamper resistant
K - Knob

Pressure Setting

Code x10 - Pressure setting in psi
(50 psi increments within specified Pressure Range)
XXX-Standard setting (see Pressure Range for value)
Example:

Code	Bar	Psi
150	103	[1500]

Pressure Range

Code	Bar	Psi
A	7-55	[100-800]
Standard Setting	28	[400]
B	17-138	[250-2000]
Standard Setting	69	[1000]
C	41-250	[600-3600]
Standard Setting	103	[1500]

Relief Valves

CP221-1

Cross-Over Relief Valve, Line Mounted

250 bar [3600 psi] • 150 l/min [40 US gpm]

DESCRIPTION AND OPERATION

This valve is an inline cross relief. It uses two CP201-1 differential area relief valves.

SCHEMATIC

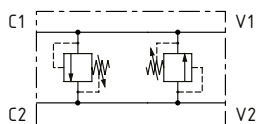

DIMENSIONS

mm [in]

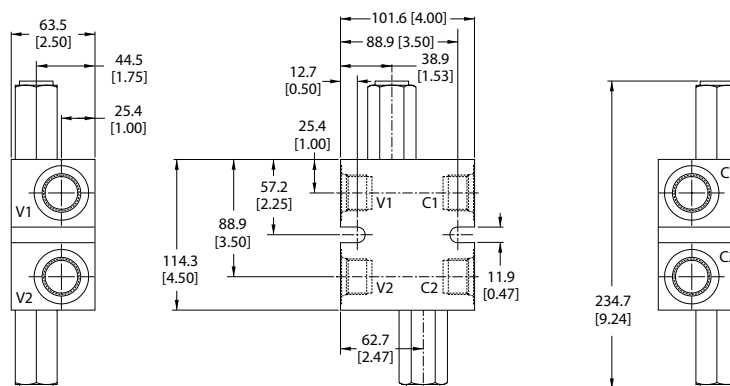

PERFORMANCE DATA

Rated pressure	250 bar [3600 psi]
Rated flow	150 l/min [40 US gpm]
Weight	2.25 kg [4.95 lb]

PERFORMANCE CURVES

Pressure Override

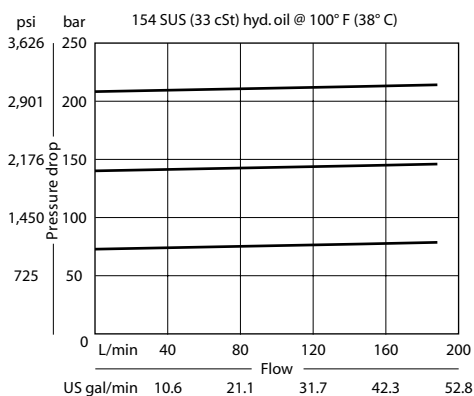

MODEL CODE

CP221 - 1 - 16S - B - 0 - A - C - 150

Housing

Code	Ports & Material	Housing Model Code
6B	AL, 3/4 BSP	221742
8B	AL, 1 BSP	221690
12S	AL, #12 SAE	220223
16S	AL, #16 SAE	220222

* Aluminum bodies are to be used for pressures less than 210 bar [3000 psi].

* Additional housings available

Seal Option

Code	Seal kit
B-Buna-N	120017
V-Viton	120018

Adjustment Option

A - Internal
E - External
F - Tamper resistant
K - Knob

Pressure Setting

Code x10 - Pressure setting in psi
(50 psi increments within specified Pressure Range)
XXX-Standard setting (see Pressure Range for value)
Example:

Code	Bar	Psi
150	103	[1500]

Pressure Range

Code	Bar	Psi
A	7-69	[100-1000]
Standard Setting	28	[400]
B	17-172	[250-2500]
Standard Setting	69	[1000]
C	41-250	[500-3600]
Standard Setting	103	[1500]

Danfoss