



Data Sheet

PLUS+1[®] Controllers

MC050-010 and MC050-012



Mobile Machine Management

The MC050-010 and MC050-012 controllers are elements of the flexible, powerful, expandable, and affordable PLUS+1 family of mobile machine management products. These devices are general-purpose controllers that are equally suited for use as members of a distributed machine control system, with intelligence in every node, or as stand-alone controllers.

Product Highlights

The MC050-010 employs a Digital Signal Processor (DSP), providing the controller with extremely fast single cycle processing speed and 256K internal flash. The MC050-012 has an application key that enables the use of Danfoss developed GUIDE machine control solutions. The same GUIDE HWD file is used with both controllers.

Application Development

Users develop MC050-010 and MC050-012 applications with PLUS+1 GUIDE. This Microsoft® Windows® based development environment features a user-friendly, field proven, icon-based graphical programming tool, application downloader, and service/diagnostic tool.

Features

- User-programmable with PLUS+1 GUIDE (Graphical User Integrated Development Environment)
- 50 pins: (1) Deutsch® DRC connector
- 32 bit fixed-point DSP running at 150 MHz
- 12 bit analog-to-digital converter
- 22 inputs
 - (6) universal (DIN/AIN/FreqIN) that are user-defined as either:
 - Analog:* with configurable ranges 0 to 5.25 Vdc (with over range protection) or 0 to 36 Vdc;
 - Digital:* pull up (5 Vdc), pull down (0 Vdc) or pull to center (2.5 Vdc);
 - Frequency (timing):* 1 Hz to 10 kHz
 - (6) digital (DIN) configurable as pull up (5 Vdc), pull down (0 Vdc)
 - (4) digital/analog (DIN/AIN) that are user-defined as either:
 - Digital:* pull up (5 Vdc), pull down (0 Vdc) or pull to center (2.5 Vdc);
 - Analog:* 0 to 5.25 Vdc or 0 to 36 Vdc
 - (4) analog (AIN/Temp/Rheo) 0 to 5.25 Vdc or 0 to 10,000 ohm rheostat
 - (2) fixed range analog (AIN/CAN shield) 0 to 5.25 Vdc or CAN shield pin
- 16 outputs
 - (10) universal (PWMOUT/DOOUT/PVGOUT) that are user-defined as either:
 - Digital:* (3 A), configurable as source or sink;
 - PWM:* (30 to 4000 Hz), configurable as open or closed loop with current control;
 - Analog voltage:* open loop PWM at 4000 Hz
 - Any PWMOUT/DOOUT/PVGOUT can be used to provide reference power to one PVG valve
 - (3) digital (DOOUT) (3 A), configurable as source only
 - (3) digital/PVG power supply (DOOUT/PVG Pwr)
 - (3 A), user-configurable; one DOOUT/PVG Pwr will power up to three PVGs
- 9 to 36 Vdc power supply, monitored internally
- 2 CAN 2.0 B ports, the fixed range analog input can be configured as the shield pin
- Power supply for external sensors rated at 5 Vdc to 450 mA, monitored and regulated internally
- 2 LEDs under user control
- 3 mounting alternatives: stack, end, or side
- MC050-012 contains application key required to run Danfoss developed machine control application software
- CE compliant

Dimensions and Pin Assignments

MC050-010 and MC050-012 Mounting Dimensions in Millimeters [Inches]

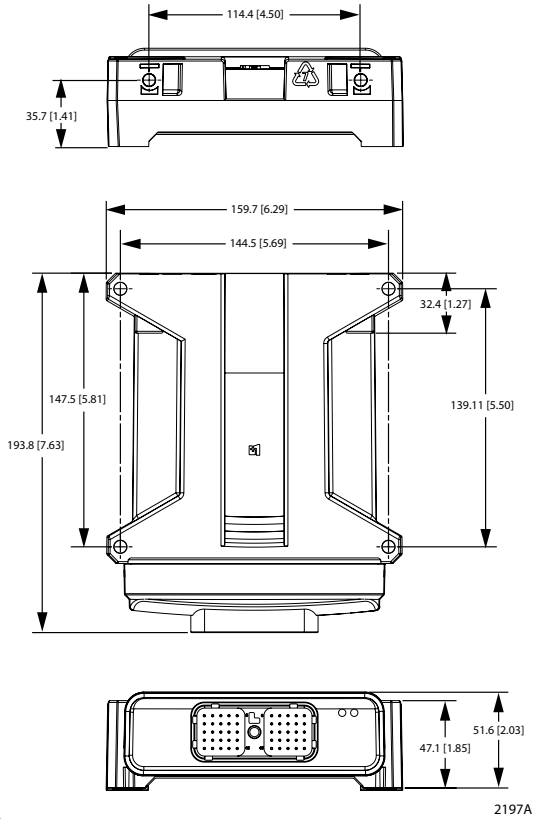

Caution
PCB damage may occur. All device power supply + pins must be connected to battery +.

Caution
This device is not field serviceable. Opening the device housing will void the warranty.

Specifications

Product Parameters

Supply voltage	9 to 36 Vdc
Operating temperature (ambient)	-40°C to 70°C [-40°F to 158°F]
Storage temperature	-40°C to 85°C [-40°F to 185°F]
Programming temperature	0°C to 70°C [32°F to 158°F]
IP rating (with mating connector attached)	IP 67
EMI/RFI rating	100 V/M
Weight	0.53 kg [1.16 lb]
Vibration	IEC 60068-2-64
Shock	IEC 60068-2-27 test Ea
Maximum current, sourcing	40 A
Maximum current, sinking	8 A

Danfoss Power Solutions (US) Company
2800 East 13th Street
Ames, IA 50010, USA
Phone: +1 515 239 6000

Danfoss Power Solutions GmbH & Co. OHG
Krokamp 35
D-24539 Neumünster, Germany
Phone: +49 4321 871 0

MC050-010 and MC050-012 50 Pin Connector

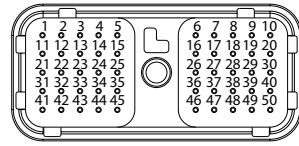

Connector

Pin	Controller function	Pin	Controller function
C1-P1	Power ground -	C1-P26*	DIN/AIN/FreqIN
C1-P2	Power supply +	C1-P27	AIN/Temp/Rheo
C1-P3	CAN0 +	C1-P28	AIN/Temp/Rheo
C1-P4	CAN0 -	C1-P29	AIN/Temp/Rheo
C1-P5	AIN/CAN0 shield	C1-P30	AIN/Temp/Rheo
C1-P6	DIN	C1-P31	DOU
C1-P7	DIN	C1-P32	DOU
C1-P8	5 Vdc sensor power +	C1-P33	DOU
C1-P9	Sensor power ground -	C1-P34	DOU/PVG Pwr
C1-P10	DIN	C1-P35	DOU/PVG Pwr
C1-P11	DIN	C1-P36	DOU/PVG Pwr
C1-P12	DIN	C1-P37	PWMOUT/DOU/PVGOUT
C1-P13	DIN	C1-P38	PWMOUT/DOU/PVGOUT
C1-P14	DIN/AIN	C1-P39	PWMOUT/DOU/PVGOUT
C1-P15	DIN/AIN	C1-P40	PWMOUT/DOU/PVGOUT
C1-P16	DIN/AIN	C1-P41	PWMOUT/DOU/PVGOUT
C1-P17	DIN/AIN	C1-P42	PWMOUT/DOU/PVGOUT
C1-P18	DIN/AIN/FreqIN	C1-P43	PWMOUT/DOU/PVGOUT
C1-P19	DIN/AIN/FreqIN	C1-P44	PWMOUT/DOU/PVGOUT
C1-P20	CAN1 +	C1-P45	PWMOUT/DOU/PVGOUT
C1-P21	CAN1 -	C1-P46	PWMOUT/DOU/PVGOUT
C1-P22	AIN/CAN1 shield	C1-P47	Power supply +
C1-P23	DIN/AIN/FreqIN	C1-P48	Power supply +
C1-P24	DIN/AIN/FreqIN	C1-P49	Power supply +
C1-P25	DIN/AIN/FreqIN	C1-P50	Power supply +

* Recommendation is to not use pin C1p26 as a frequency input. If used, recommendation is to disable internal filtering and use filter inside the application instead.

Use care when wiring mating connector. Above pinouts are for device pins.

Product Part Number

MC050-010	10100900
MC050-012	11013734

Related Products Part Numbers

CG150 CAN/USB Gateway	10104136	
Deutsch® mating connector bag assembly	10102024 (16 to 20 AWG)	10100946 (20 to 24 AWG)
PLUS+1 GUIDE single user license	10101000	

Danfoss comprehensive *technical information* on line at: www.danfoss.com

Danfoss Power Solutions Trading (Shanghai) Co. Ltd.
Building #22, No. 1000 Jin Hai Rd
Jin Qiao, Pudong New District
Shanghai, China 201206
Phone: +86 21 3418 5200

Danfoss can accept no responsibility for possible errors in catalogues, brochures and other printed material. Danfoss reserves the right to alter its products without notice. This also applies to products already on order provided that such alterations can be made without changes being necessary in specifications already agreed. All trademarks in this material are property of the respective companies. Danfoss and the Danfoss logotype are trademarks of Danfoss A/S. All rights reserved.