



Data Sheet

PLUS+1[®] Controllers

MC050-055 and MC050-05B



PLUS+1

Mobile Machine Management

MC050-055 and MC050-05B controllers are elements of the flexible, powerful, expandable, and affordable PLUS+1 family of mobile machine management products. These devices are general-purpose controllers that are equally suited for use as members of a distributed machine control system, with intelligence in every node, or as stand-alone controllers.

Product Highlights

Both controllers employ a Digital Signal Processor (DSP), providing the controllers with extremely fast single cycle processing speed and 256K internal flash. Both controllers feature three CAN ports, three-level regulated sensor power supply, and 1 Mbyte external RAM. The MC050-05B has an application key that enables the use of Danfoss developed GUIDE machine control solutions. The same GUIDE HWD file is used with both controllers.

Application Development

Users develop MC050-055 and MC050-05B applications using PLUS+1 GUIDE. This Microsoft® Windows® based development environment features a user-friendly, field proven, icon-based graphical programming tool, application downloader, and service/diagnostic tool.

Features

- User-programmable with PLUS+1 GUIDE (Graphical User Integrated Development Environment)
- 50 pins: 1 Deutsch® DRC connector
- 32 bit fixed-point DSP running at 150 MHz
- 12 bit analog-to-digital converter
- 36 inputs
 - 4 universal (DIN/AIN/FreqIN) that are user-defined as either:
 - Analog:* with configurable ranges 0 to 5.25 Vdc (with over range protection) or 0 to 16 Vdc
 - Digital:* pull up (5 Vdc), pull down (0 Vdc) or pull to center (2.5 Vdc)
 - Frequency (timing):* 1 Hz to 10 kHz
 - 29 digital/analog (DIN/AIN) that are user-defined as either:
 - Digital:* pull up (5 Vdc), pull down (0 Vdc) or pull to center (2.5 Vdc)
 - Analog:* 0 to 5.25 Vdc or 0 to 16 Vdc
 - 3 fixed range analog (AIN/CAN shield) 0 to 5.25 Vdc or CAN shield pin
- 3 outputs
 - 2 universal (PWMOUT/DOUT/PVGOUT) that are user-defined as either:
 - Digital:* (3 A), configurable as source or sink
 - PWM:* (30 to 4000 Hz), configurable as open or closed loop with current control
 - Analog voltage:* open loop PWM at 4000 Hz
 Any PWMOUT/DOUT/PVGOUT can be used to provide reference power to one PVG valve
 - 1 digital (DOUT) 3 A, configurable as source only
- 9 to 16 Vdc power supply, monitored internally
- 3 CAN 2.0 B ports, the fixed range analog input can be configured as the shield pin
- Power supply for external sensors, monitored and regulated internally
 - 1.6 Vdc rated at 500 mA
 - 3.3 Vdc rated at 450 mA
 - 5.0 Vdc rated at 450 mA
- 2 LEDs under user control
- 3 mounting alternatives: stack, end, or side
- MC050-05B contains the application key required to run Danfoss developed machine control application software
- CE compliant

MC050-055 and MC050-05B Dimensions and Pin Assignments

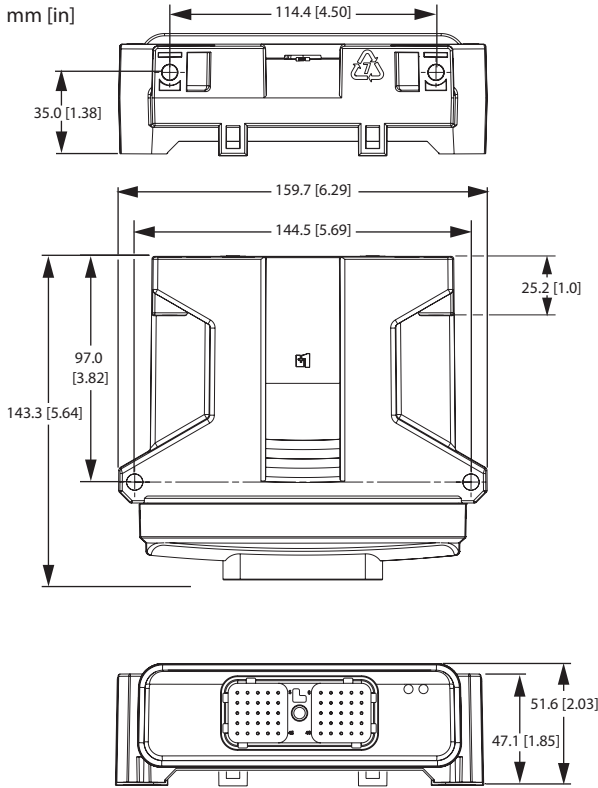

Caution
PCB damage may occur. All device power supply + pins must be connected to battery +.

Caution
This device is not field serviceable. Opening the device housing will void the warranty.

MC050-055 and MC050-05B 20 Pin Connector

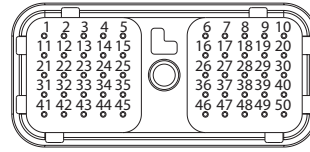

2198B

Connector

Pin	Controller function	Pin	Controller function
C1-P1	Power ground -	C1-P26	DIN/AIN
C1-P2	Power supply +	C1-P27	DIN/AIN
C1-P3	CAN0+	C1-P28	DIN/AIN
C1-P4	CAN0-	C1-P29	DIN/AIN
C1-P5	AIN/CAN0 shield	C1-P30	DOUT
C1-P6	CAN1+	C1-P31	DIN/AIN
C1-P7	CAN1-	C1-P32	DIN/AIN
C1-P8	3.3/5 Vdc sensor power +	C1-P33	DIN/AIN
C1-P9	Sensor power ground -	C1-P34	DIN/AIN
C1-P10	1.66 Vdc sensor power +	C1-P35	DIN/AIN
C1-P11	CAN2+	C1-P36	DIN/AIN
C1-P12	CAN2-	C1-P37	DIN/AIN
C1-P13	AIN/CAN1 shield	C1-P38	DIN/AIN
C1-P14	AIN/CAN2 shield	C1-P39	DIN/AIN
C1-P15	DIN/AIN	C1-P40	PWMOUT/DOUT/PVGOUT
C1-P16	DIN/AIN	C1-P41	DIN/AIN
C1-P17	DIN/AIN	C1-P42	DIN/AIN
C1-P18	DIN/AIN	C1-P43	DIN/AIN
C1-P19	DIN/AIN	C1-P44	DIN/AIN
C1-P20	DIN/AIN	C1-P45	DIN/AIN
C1-P21	DIN/AIN	C1-P46	DIN/AIN/FreqIN
C1-P22	DIN/AIN	C1-P47	DIN/AIN/FreqIN
C1-P23	DIN/AIN	C1-P48	DIN/AIN/FreqIN
C1-P24	DIN/AIN	C1-P49	DIN/AIN/FreqIN
C1-P25	DIN/AIN	C1-P50	PWMOUT/DOUT/PVGOUT

Use care when wiring mating connector.
Above pinouts are for device pins.

Specifications

Supply voltage	9 to 16 Vdc
Operating temperature (ambient)	-40°C to 70°C [-40°F to 158°F]
Storage temperature	-40°C to 85°C [-40°F to 185°F]
Programming temperature	0°C to 70°C [32°F to 158°F]
IP rating (with mating connector attached)	IP 67
EMI/RFI rating	100 V/m
Weight	0.40 kg [0.88 lb]
Maximum current, sourcing	8 A
Maximum current, sinking	6 A

Ordering Information

MC050-055	11051617
MC050-05B	11071900

Related product	Danfoss material number	
CG150 CAN/USB Gateway	10104136	
Deutsch® mating connector bag assembly	10102024 (16 to 20 AWG)	10100946 (20 to 24 AWG)
PLUS+1 GUIDE single user license	10101000	

Comprehensive technical information: PLUS+1 Controller Family Technical Information, **520L0719** and MC050-055/MC050-05B Application Program Interface (API) Document. Danfoss product literature on-line at: www.Danfoss.com

Danfoss Power Solutions US Company
2800 East 13th Street
Ames, IA 50010, USA
Phone: +1 515 239 6000

Danfoss Power Solutions GmbH & Co. OHG
Krokamp 35
D-24539 Neumünster, Germany
Phone: +49 4321 871 0

Danfoss Power Solutions ApS
Nordborgvej 81
DK-6430 Nordborg, Denmark
Phone: +45 7488 2222

Danfoss Power Solutions (Shanghai) Co. Ltd.
Building #22, No. 1000 Jin Hai Rd
Jin Qiao, Pudong New District
Shanghai, China 201206
Phone: +86 21 3418 5200

Danfoss can accept no responsibility for possible errors in catalogues, brochures and other printed material. Danfoss reserves the right to alter its products without notice. This also applies to products already on order provided that such alterations can be made without subsequent changes being necessary in specifications already agreed. All trademarks in this material are property of the respective companies. Danfoss and the Danfoss logotype are trademarks of Danfoss A/S. All rights reserved.