



3500 Annapolis Lane North, Minneapolis, MN 55447  
 Telephone: (763) 509-2084 Telefax: (763) 559-0108

# Unit Specification

## KE04201 Valve Drive Amplifier

ISSUE: 3

DATE: September 1996

### GENERAL DESCRIPTION

The device is a free-standing amplifier mounted on 4 standoffs. Voltage from a sensor potentiometer, through the amplifier, produces current to drive electrohydraulic actuators. Connections to the amplifier are via screw terminals. An external switch can change gain settings by shorting between two terminals.

### DIMENSIONS

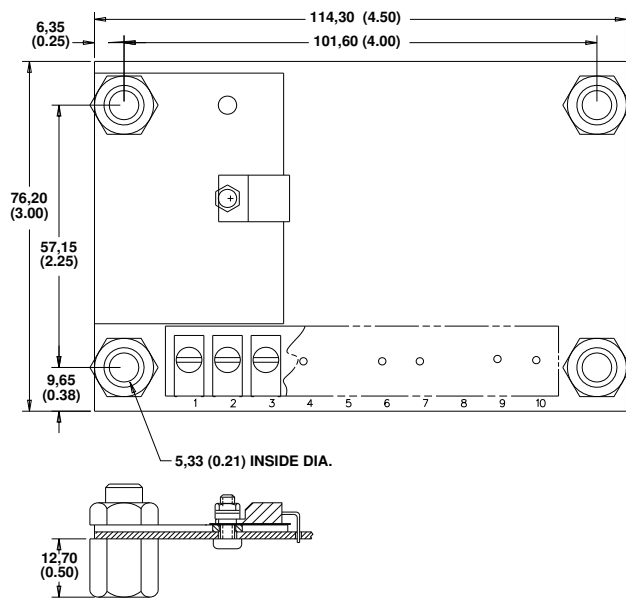

1647

Dimensions of the KE04201 in Millimeters (Inches).

### CONNECTION DIAGRAM

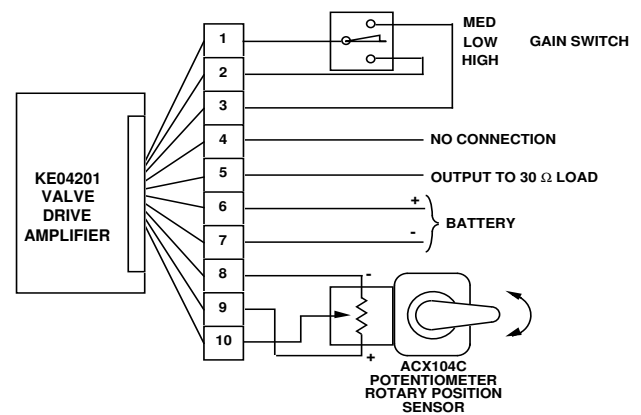

POLARITY OF BATTERY CONNECTIONS MAY BE REVERSED TO CHANGE ACTION OUTPUT VERSUS SENSOR INPUT

GAIN SWITCH IS OPTIONAL. JUMPERS MAY BE USED IN PLACE OF SWITCH

1648

### OUTPUT CHARACTERISTICS

SUPPLY VOLTAGE  
24 Vdc (22 to 30 Volts)

TURN ON VOLTAGE  
48% of supply

MAXIMUM OUTPUT CURRENT  
600 mA to 30 Ω Load

% MAXIMUM  
OUTPUT VOLTAGE

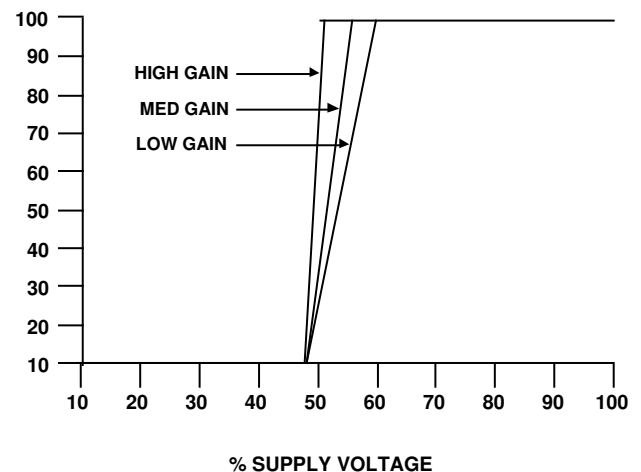

1649A