



3500 Annapolis Lane North, Minneapolis, MN 55447
 Telephone: (763) 509-2084 Telefax: (763) 559-0108

Unit Specification

KE04106 Valve Drive Amplifier

ISSUE: 2

DATE: September 1996

GENERAL DESCRIPTION

The device is a free-standing amplifier mounted on 4 standoffs. Current or voltage signal from a transducer/controller, through the amplifier, produces current to drive electrohydraulic actuators. Connections to the amplifier are via screw terminals.

DIMENSIONS

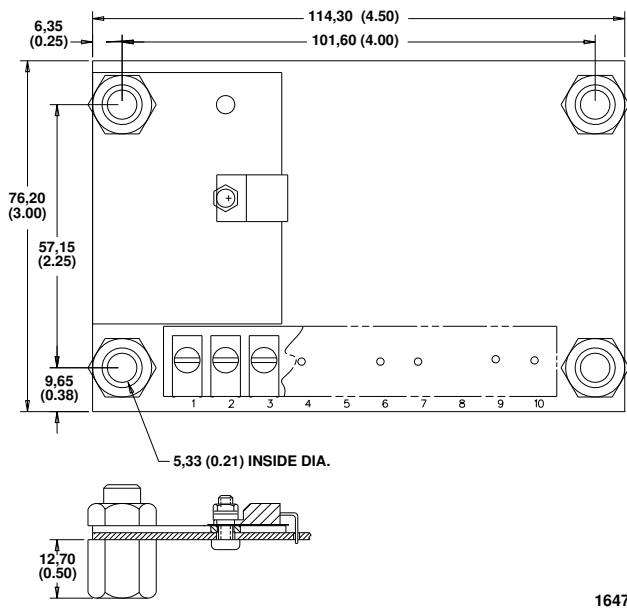

Dimensions of the KE04106 in Millimeters (Inches).

CONNECTION DIAGRAM

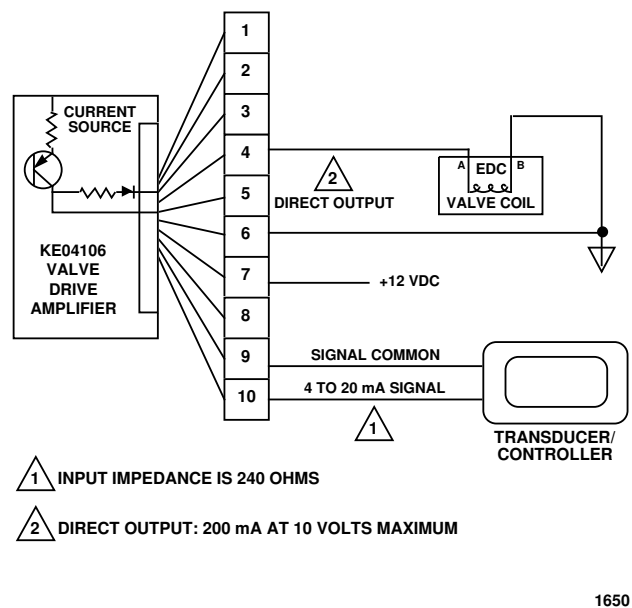

OUTPUT CHARACTERISTICS

SUPPLY VOLTAGE
12 Vdc (11 to 15 Volts)

INPUT IMPEDENCE
240 ohm

START CURRENT
4 mA nominal (1 Volt)

FULL STROKE CURRENT
20 mA (4.8 Volts)

MAXIMUM OUTPUT CURRENT
100 mA into a 25 ohm load

% MAXIMUM
OUTPUT VOLTAGE

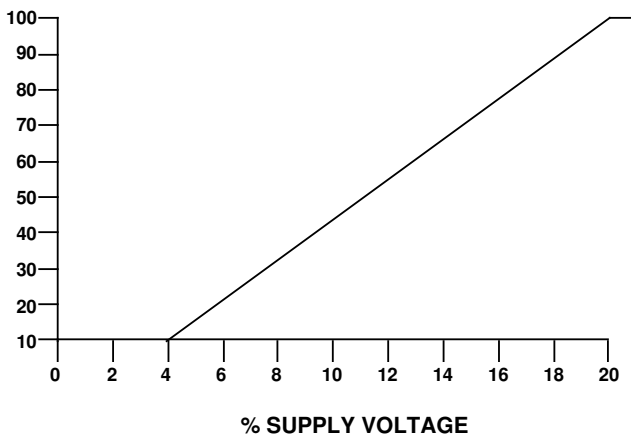

1651A