



MCW102A,C

Time Proportional Rotary Position Controller

BLN-95-9048

Issued: March 1995

DESCRIPTION

The MCW102A and MCW102C Time Proportional Rotary Position Controllers provide automatic grade control on paving, curbing and planing machines. The Controller uses a follower arm riding on a stringline or a ski riding on the prepared surface as a grade reference. The controllers activate solenoid valves to position a screed, form cutting drum, or steer cylinder.

The MCW102A and C are time proportional devices having valve on - time proportional to grade error. This feature causes the output to the solenoid to be on a greater percentage of the time for larger grade deviations, allowing greater sensitivity to grade deviations than would otherwise be possible. The "A" model is ground-side switched and the "C" model is high-side switched.



FEATURES

- Non-contacting sensing element for long life
- Fully burned-in components for added reliability
- Bright up/down lights for easy nulling
- Adjustable deadband sensitivity
- Run/Standby switch for manual or automatic control
- Reverse polarity and short circuit protection
- Rugged aluminum housing
- Withstands high vibration and shock
- Moisture and corrosion resistant
- Easy to mount
- Adjustable tracking force

ORDERING INFORMATION

SPECIFY

1. Model Number MCW102A1005 (ground-side switching)
Model Number MCW102C1002 (high-side switching)
2. Valve load to be driven
3. Accessories
4. Service parts

ACCESSORIES

1. KG04003, Right Angle Grade Follower
With breakaway joint. For grade applications only. Follows a stringline. Also used with skate assembly, or skate and ski assembly for following hard reference surface.
2. K09274, Right Angle Grade Follower Less Sensing Arm
For grade applications utilizing the skate and/or skate and ski assembly. Same as part number KG04003 above, but without the sensing arm and breakaway joint.
3. KG06001, Skate Assembly
For grade applications. Used with right angle grade follower (part number K09274) on hard reference surface.

4. KG02001, Ski Assembly
For grade applications. Used with right angle grade follower (part number K09274), and skate assembly (part number KG06001) on hard reference surface.

5. Cable Assemblies:
KW01013 – Two-foot coiled cable that extends to ten feet. Has right angle connector on one end and straight connector on the other to make connections between the MCW102 and Bendix Type No. MS3102A18-1P plug (part number K03989).

KW01035 – Two-foot coiled cable that extends to ten feet. Has right angle connector on one end and straight connector on the other to make connections between the MCW102A and the paving machine bulkhead.

STRAIGHT CONNECTOR	90° CONNECTOR
A	A
B	B
C	E
D	F
E	C
F	D

ORDERING INFORMATION (continued)

KW01015 – Two-foot coiled cable that extends to ten feet. Has two straight connectors to make connections between the MCW102C and the paving machine bulkhead.

KW01034 – Two-foot coil cable that extends to ten feet, has right angle connector on one end and straight connector on the other end to make connections between the MCW101 and paving machine bulkhead.

STRAIGHT CONNECTOR	90° CONNECTOR
A	A
B	B
F	E
E	F

6. K00702 Lens (service part)
7. K03891 Lamp (service part)

TECHNICAL DATA

ELECTRICAL

SUPPLY VOLTAGE

12 volts
0.5 amps
Does not include output current to load.

MAXIMUM OUTPUT CURRENT @ 14 VDC SUPPLY

2.5 amp with 5 ohm load
The MCW102A has ground-side switching
The MCW102C has high-side switching

MAXIMUM REVERSED POLARITY VOLTAGE

50 Vdc for 5 minutes

SHORT CIRCUIT PROTECTION

The controllers are protected against short circuits across the valve coil as well as shorts between the outputs and ground. A short circuit is defined as 1 ohm maximum resistance for 5 minutes maximum.

LOAD DUMP

Protected against load dump per SAE J2.20.97

MECHANICAL

Physical stops limit the rotation to approximately $\pm 23^\circ$ from null.

ENVIRONMENTAL

OPERATING TEMPERATURE

-18° to 65° C (0° to 150° F)

STORAGE TEMPERATURE

-30° to 65° C (-22° to 150° F)

HUMIDITY

After being placed in a controlled atmosphere of 95% humidity at 38° C for 10 days, the controller will perform within specification limits.

RAIN

The controller will withstand exposure to a 15 minute shower with cold water after reaching the maximum storage temperature.

VIBRATION

Withstands a vibration test designed for mobile equipment controls consisting of two parts:

1. Cycling from 5 to 2000 Hz in each of the three axes.
2. Resonance dwell for one million cycles for each resonant point in each of the three axes.

Run from 1 g to 8 g's. Acceleration level varies with frequency.

SHOCK

50g for 11 milliseconds. Three shocks in both directions of the three mutually perpendicular axes for a total of 18 shocks.

DIMENSIONS

See the Dimensions Drawing.

DIMENSIONS

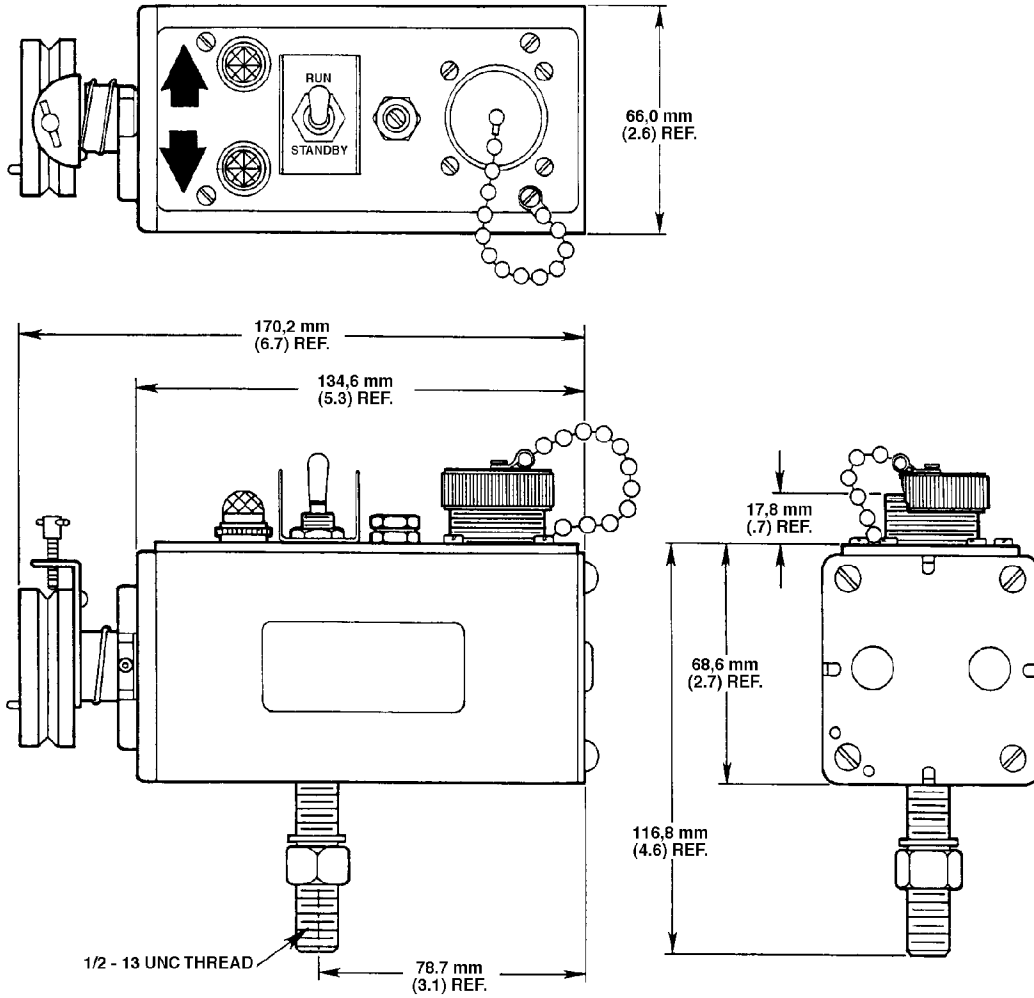

Dimensions of the MCW102A, C in Millimeters (Inches).

1304

TECHNICAL DATA (continued)

PERFORMANCE

TEST CONDITIONS

SUPPLY: 14 Vdc
 LOAD: 5 ohm minimum
 DEADBAND: Maximum (full ccw)
 RUN/STANDBY SWITCH: Run
 TEMPERATURE: 25° C
 Shaft rotation measured at end of 4.25 inch long horizontal arm. (Equivalent to a standard 6 inch long sensing arm trailing at 45°).

MAXIMUM TORQUE

6.0 in-gms required to rotate the shaft from either side of null to the stop.

NULL CENTERING

With the shaft roll pin centered between the stops, electrical null will occur within ± 0.37 inches.

MAXIMUM TEMPERATURE NULL SHIFT

0.15 inch vertical deflection over the range from 0° to 50° C (32° to 122° F). A larger null shift may occur over a greater temperature span. It is recommended that the user re-null the Controller each morning before using. See the Adjustment section.

PHASING

Facing the hub with the lamps up, a clockwise shaft rotation will make pin F positive with respect to pin E. The right lamp will come on.

PROPORTIONAL BAND

.33 \pm .08 inches

FREQUENCY OF OUTPUT PULSES

MCW102A1005	3 \pm 1 Hz
MCW102C1002	
MCW102C1011	
MCW102A1013	4.5 \pm 1 Hz

MINIMUM OUTPUT PULSE WIDTH

MCW102A1005	37 \pm 12 ms
MCW102C1002	
MCW102C1011	
MCW102A1013	50 \pm 12 ms

DEADBAND ADJUSTMENT

Overlap to a minimum of 0.12 inches

NULL POINT STABILITY

Changes in supply voltage from 11 to 15 Vdc will not change the null point more than 0.02 inches.

RUN/STANDBY SWITCH

On Standby, output will be 0 \pm 1 mA.

THEORY OF OPERATION

Both the MCW102A and MCW102C Controllers consist of two stages: a sensor input and an amplifying/controlling section. See the MCW102A and MCW102C Block Diagrams. The sensor input section accepts steering or grade information through either a right angle or straight tube follower. Right angle followers are used to sense grade and are either tubular (for stringlines) or skate and ski (for firm reference surfaces). As the reference is raised or lowered the hub shaft is rotated so that the follower maintains contact.

As the hub shaft turns, it rotates a U-shaped magnet that is attached inside the device housing. A non-contact sensor is mounted to the housing between the poles of the magnet, and as the angle of the flux lines passing through the sensor changes with the follower, the voltage from the sensor varies. The timed output voltage is proportional to the angle of rotation over the sensing range.

The amplifier sums the error signal from the sensor with a 3 Hz triangular wave to effect the time proportioning. See the Triangular Wave drawing.

The sum is compared to an upper and lower reference voltage to drive the output. The separation between the references (the deadband) is adjustable through a trim potentiometer on the front panel. At minimum sensitivity (wide deadband), a ± 0.06 inch (six inch grid arm at a 45° angle) error signal will produce valve drive. At maximum sensitivity

(narrow deadband), both valve drives occur at the peaks of the triangular waves, even when the system receives no error signal. Two front-panel incandescent lamps light as the valve drive trigger is activated.

TRIANGULAR WAVE

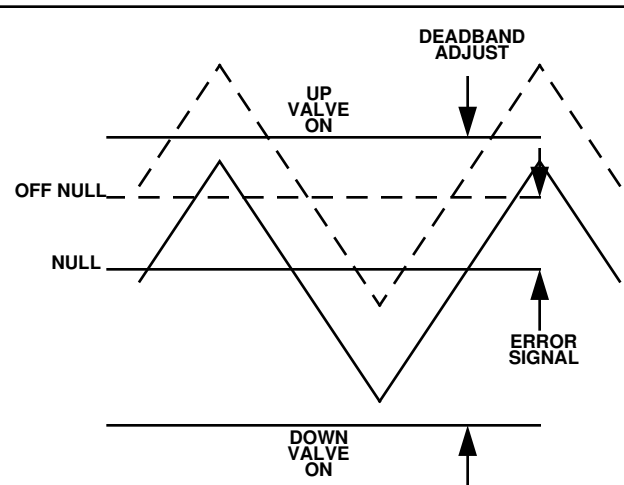

Triangular Wave Summed With Error Voltage In Null (Solid Line) And Off Null (Broken Line) Conditions.

MCW102A BLOCK DIAGRAM (Ground Side Switching)

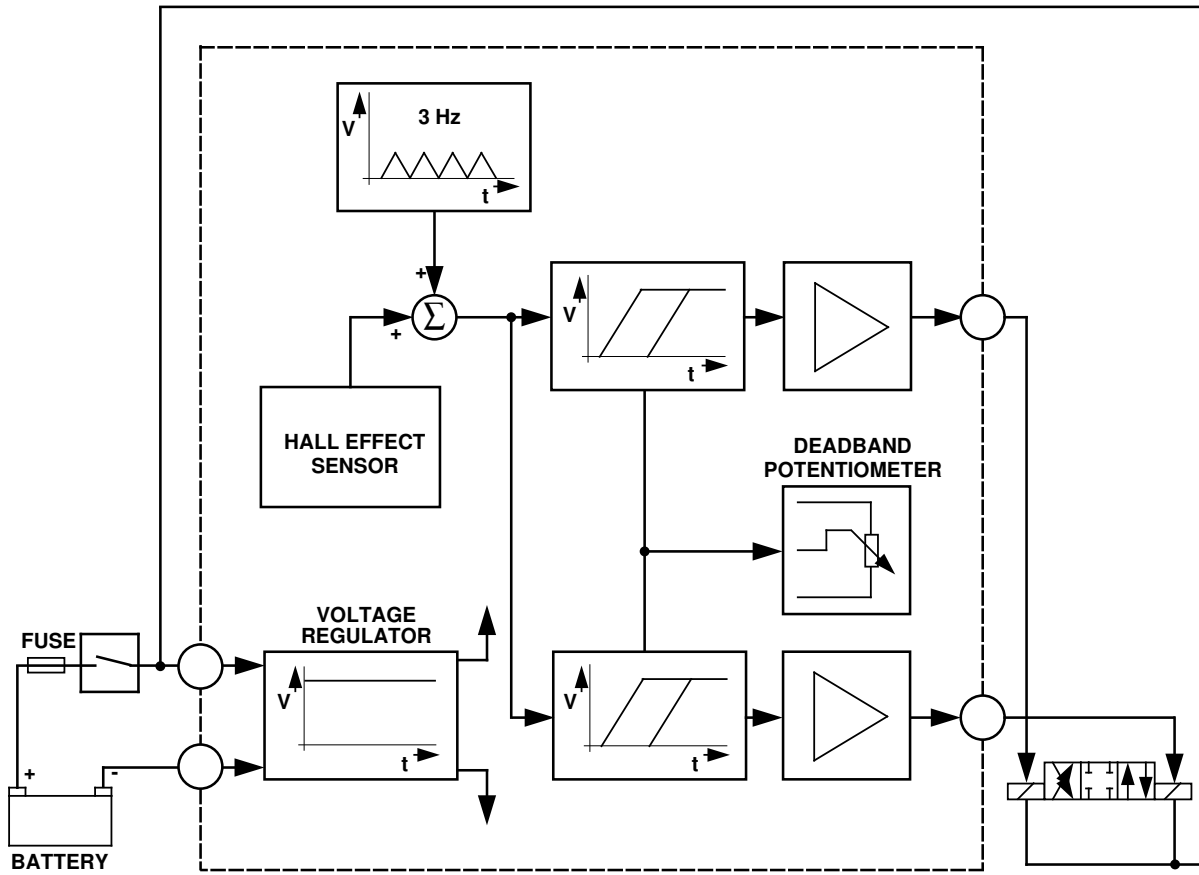

1741

MCW102C BLOCK DIAGRAM (High Side Switching)

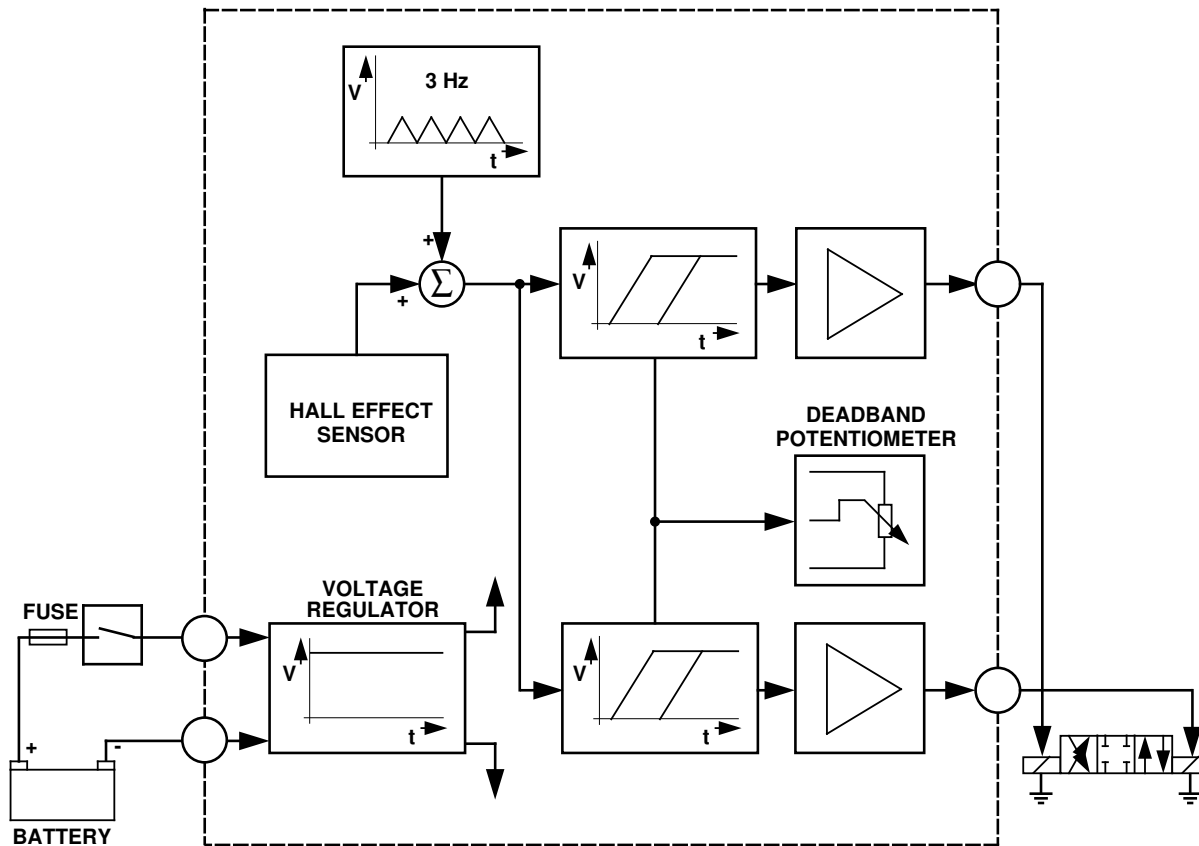

1742

MOUNTING

Determine the mounting location, and drill a 9/16-inch (14 mm) hole for the mounting stud. Remove the nut and lockwasher. Mount the MCW102 with the shaft horizontal. Tighten the nut against the lockwasher, but not too tightly, since it must be loosened in the adjustment procedure.

Attach the appropriate follower to the hub. Note the guide hole location and direction of travel.

After the follower has been installed, adjust the spring on the hub so the follower exerts a very light pressure on the stringline or reference surface.

A skate assembly, part number KG06001, and ski assembly, part number KG02001, may be used with the right angle follower, part number KG04003 when a firm reference surface is used. When using these devices, hub spring tension is comparatively unimportant.

WIRING

All wiring connections are made through a 10 Pin MS Connector located on the end of the front panel of the device. A two-foot coiled cable that extends to ten feet is available with plugs for easy connection and removal. A straight plug is provided on one end and a right angle plug on the other (part

number KW01013), or two straight plugs (part number KW01014). Use an MS3102A18-1P connector (part number K03989) on the machine for cable connections. See the MCW102A and MCW102C Connection Diagrams.

ADJUSTMENT

1. Place the Run/Standby switch on Standby.
2. Loosen deadband potentiometer locknut.
3. Turn the deadband potentiometer fully counterclockwise to minimum deadband.
4. Apply electrical power to the system. Hydraulic power is not necessary at this time.
5. With the equipment at the correct grade position, adjust the vertical position of the MCW102 until the lights are blinking for the same amount of time, or until an equivalent angular deflection causes the lamps to fire. Lock the controller in place.
6. Turn the potentiometer back approximately 1/4 turn.
7. Turn on the hydraulic power and place the Run/Standby switch on Run.
8. Observe the response of the machine. If it oscillates when returning to null, turn the potentiometer clockwise. If the machine slowly approaches null but stops short, turn the potentiometer counterclockwise.
9. Tighten locknut on deadband potentiometer.

TROUBLESHOOTING

Keep the following facts in mind while troubleshooting the system:

- The lights will indicate deviations whenever power is applied to the MCW102, regardless of the Run/Standby switch position.
 - In the Run position, amplifier output is connected to the solenoid. In the Standby position, it is not.
 - If the deadband potentiometer is turned fully clockwise (maximum deadband), a large deviation will be needed to command an output to the solenoid.
 - Preliminary checks should include examination of the cables and leads for damaged or broken wire. Examine areas where shorting may occur. Check the power supply to be sure it is greater than 11 volts.
1. Check for free rotation, proper spring loading and tightness in all sensor grid parts.
 2. Unhook the MCW102 cables and manually operate the solenoids to check for correct operations. Re-connect the cables.
 3. Check the lights when the controller is in the Standby mode. Vary the machine position manually and note the indication. One light and then the other should glow as the conditions are reversed.
 4. If another controller is available, set it on the same surface as the other and plug the MS connector into the replacement unit. Check system operation. If the problem disappears, the controller is defective. Substitute the replacement and return the old device as outlined in the Ordering Information.

MCW102A CONNECTION DIAGRAM

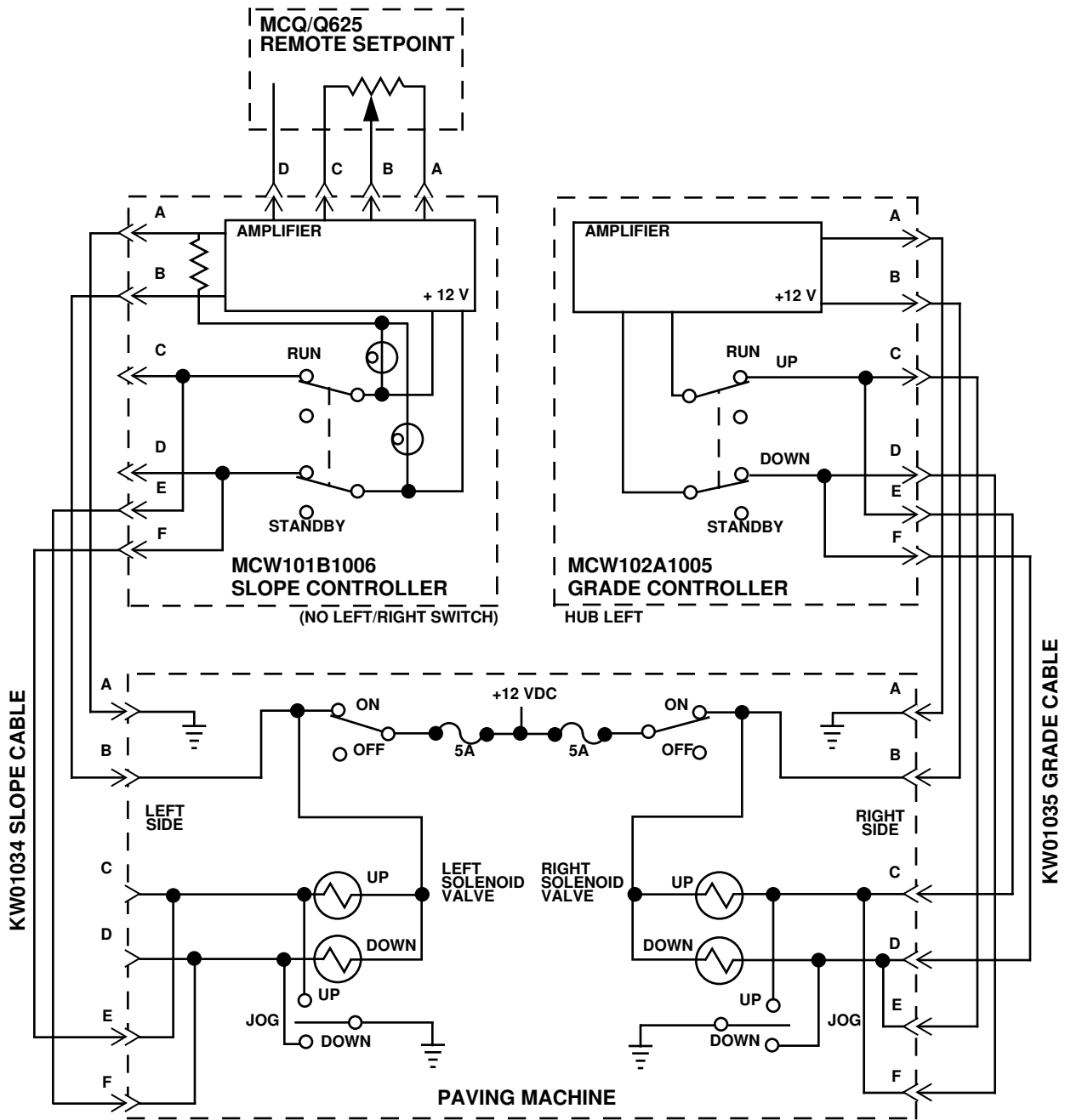

1743

MCW102A Used in a Grade and Slope System with Ground-Side Switching and Four Pin Machine Connection.

MCW102C CONNECTION DIAGRAM

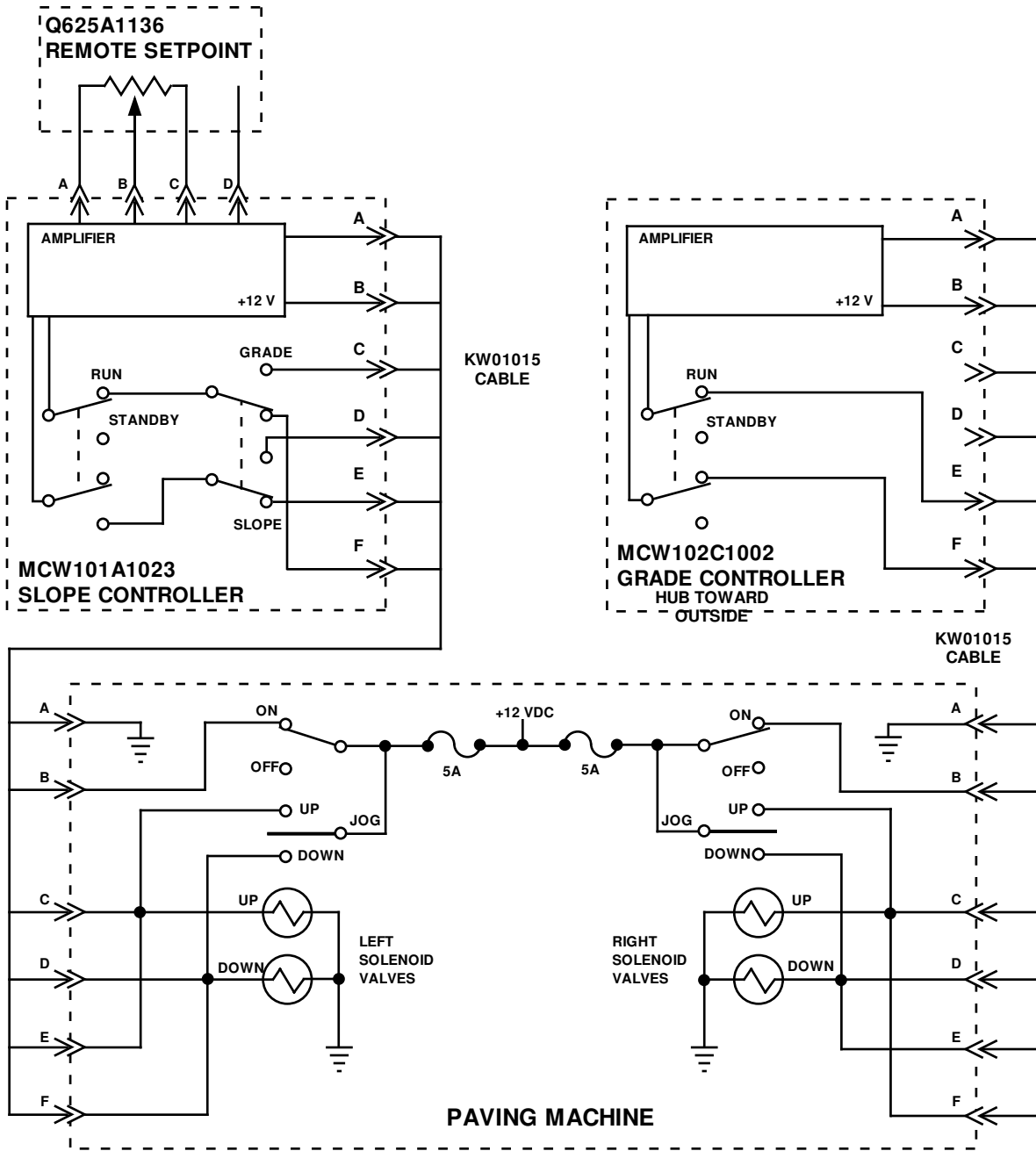

1744

MCW102C Used in a Grade and Slope System with High-Side Switching and Six Pin Machine Connection.

CUSTOMER SERVICE

NORTH AMERICA

ORDER FROM

Danfoss (US) Company
Customer Service Department
3500 Annapolis Lane North
Minneapolis, Minnesota 55447
Phone: (763) 509-2084
Fax: (763) 559-0108

DEVICE REPAIR

For devices in need of repair, include a description of the problem, a copy of the purchase order and your name, address and telephone number.

RETURN TO

Danfoss (US) Company
Return Goods Department
3500 Annapolis Lane North
Minneapolis, Minnesota 55447

EUROPE

ORDER FROM

Danfoss (Neumünster) GmbH & Co.
Order Entry Department
Krokamp 35
Postfach 2460
D-24531 Neumünster
Germany
Phone: 49-4321-8710
Fax: 49-4321-871-184