



# MCE102A Automotive Controller

BLN-95-8993-3

Issued: May 1998

## DESCRIPTION

The MCE102A automotive controller enables hydrostatically powered vehicles to operate in a manner similar to a car's automatic transmission. The automotive control maintains a definite relationship between the engine r.p.m. and the swashplate angle (i.e., displacement) of the variable displacement pump used in the hydrostatic transmission. The transmission ratio (displacement of the pump/displacement of the motor) increases with increasing engine r.p.m. Vehicle speed is obtained by depressing the throttle pedal which controls the vehicle engine r.p.m.



## ORDERING INFORMATION

DEVICE NUMBER	SUPPLY VOLTAGE	OUTPUT CURRENT	INTERNAL SETPOINT RANGE	CONNECTOR TYPE	MISCELLANNEOUS
MCE102A1007	12 Vdc	.14 amp	200 to 900 Hz	Packard	External Inch Pot
MCE102A1014	12 Vdc	.14 amp	200 to 900 Hz	Packard	External Foot Break
MCE102A1022	12 Vdc	.14 amp	50 to 225 Hz	Terminal Strip	External F/V Turn Down
MCE102A1030	24 Vdc	.7 amp	4 to 20 mA	Packard	Reverse Acting
MCE102A1049	12 Vdc	1.0 amp	10 to 50 Hz	Terminal Strip	Lead/Lag Filter
MCE102A1055	12 Vdc	.7 amp	90 to 500 Hz	Packard	Pressure Transducer Turn Down
MCE102A1063	12 Vdc	1.0 amp	200 to 650 Hz	Terminal Strip	Lead/Lag Filter, 2 Speed
MCE102A1071	24 Vdc	.7 amp	4 to 20 mA	Terminal Strip	Reverse Acting
MCE102A1097	12 Vdc	1.0 amp	200 to 650 Hz	Terminal Strip	Lead/Lag Filter, 2 Speed
MCE102A1105	12 Vdc	.14 amp	1000 to 3000 Hz	Terminal Strip	Lead/Lag Filter
MCE102A1113	12 Vdc	.14 amp	200 to 650 Hz	Terminal Strip	Lead/Lag Filter
MCE102A1121	12 Vdc	1.0 amp	600 to 1950 Hz	Terminal Strip	Lead/Lag Filter, 2 Speed
MCE102A1139	24 Vdc	.14 amp	1000 to 3000 Hz	Terminal Strip	Lead/Lag Filter
MCE102A1147	12 Vdc	.14 amp	200 to 650 Hz	Packard	Lead/Lag Filter

## TECHNICAL DATA

### ELECTRICAL

#### SUPPLY VOLTAGE

12 Vdc nominal (11 to 15 Vdc range)  
24 Vdc nominal (22 to 30 Vdc range)

#### OUTPUT CURRENT

1.0 amps maximum in auto mode (12 Vdc models)  
0.7 amps maximum in auto mode (24 Vdc models)

#### OUTPUT VOLTAGE

System supply voltage less 3 volts, maximum (limited by a series resistor on some models).

### REVERSE VOLTAGE PROTECTION

A series diode protects against reverse voltage up to 50 Vdc

### SHORT CIRCUIT PROTECTION

1.4 to 2.0 amps (12 Vdc models)  
0.8 to 1.2 amps (24 Vdc models)  
Shorted load of more than 2 minutes may degrade device at elevated temperature. Output limited by a series resistor on some models.

## TECHNICAL DATA (continued)

### ENVIRONMENTAL

#### VIBRATION

Withstands a vibration test designed for mobile equipment controls consisting of two parts:

1. Cycling from 5 to 2000 Hz in each of the three axes
2. Resonance dwell for one million cycles in each of the three axes

Run from 1 to 10 Gs. Acceleration level varies with frequency.

#### HUMIDITY

After being placed in a controlled atmosphere of 95% humidity at 38° C (100° F) for 10 days, the controller will perform within specification limits.

#### RAIN

After being showered from all directions by a high pressure hose down, the controller will perform within specification limits.

#### SHOCK

50 Gs for 11 milliseconds. Three shocks in both directions of the three mutually perpendicular axes for a total of 18 shocks.

#### OPERATING TEMPERATURE

-20 to 65° C (-4 to 149° F)

#### STORAGE TEMPERATURE

-30 to 65° C (-22 to 149° F)

### PERFORMANCE

#### MAXIMUM OUTPUT VOLTAGE

The maximum output voltage to the load shall be the supply voltage less three volts up to rated load current.

#### MAXIMUM OUTPUT CURRENT

With the output terminal shorted to ground, the maximum output current shall be from 1.4 to 2.0 amps (12 Vdc models) or 0.8 to 1.2 amps (24 Vdc models), depending on temperature.

#### OPERATING SUPPLY VOLTAGE

11 to 15 Vdc, or 24 to 30 Vdc optional with added components

#### SUPPLY CURRENT

1.1 amps maximum (except for shorted loads) (12 Vdc models)

0.8 amps maximum (except for shorted loads) (24 Vdc models)

#### VOLTAGE RANGE

The controlled voltage decreases from supply minus 3 volts down to zero.

#### SENSITIVITY

The sensitivity control changes the proportioning band from 4% (turned clockwise) to 75% (turned counter clockwise) of calibrated r.p.m. The proportioning band is defined as the change necessary to reduce output voltage from 100% to 20% of rated output. Sensitivity control may be removed and replaced with a fixed resistance in some models.

## THEORY OF OPERATION

The automotive controller monitors engine r.p.m. as a variable frequency through the alternator or pulse pickup. The controller's calibration (point of maximum displacement) is at or near the r.p.m. at which the engine is capable of maximum horsepower. The output is directed to the pump displacement control through a double-pole double-throw center off switch. For vehicle forward, neutral and reverse, see Automotive Control System Diagram.

Between low idle and low r.p.m., the engine is well below setpoint (see Controller Output Vs. Engine RPM and Reverse Acting Controller), which the controller interprets as a lugged condition; consequently there is no propel. As engine r.p.m. increases, the controller output increases, the rate of increase being determined by the gain setting of the controller. The engine r.p.m. that corresponds to maximum ratio is determined by the engine r.p.m. calibration potentiometer. Vehicle speed will continue to increase with increasing engine r.p.m. even though the transmission ratio remains unchanged above the high r.p.m. calibration point.

The transmission ratio is proportional to engine r.p.m., and overhauling loads resulting in high engine r.p.m. will keep the pump at full angle, resulting in dynamic braking limited by the engine horsepower absorption. Therefore, to guarantee

adequate braking, the vehicle mechanical brake must be applied.

The automotive controller is adaptable to applications with either medium or heavy duty transmissions. Additional features such as HI/LOW range, reverse acting, pressure transducer turn down, lead/lag and inching may also be incorporated into the system.

The feedback circuit may be modified to accept a dc signal. 4 to 20 mA from a pressure transducer or 0 to 6 Vdc from a tachometer are two types of dc signals acceptable for feedback.

The unit may be modified to provide decreasing output for increasing r.p.m. (reverse acting).

# AUTOMOTIVE CONTROL SYSTEM DIAGRAM

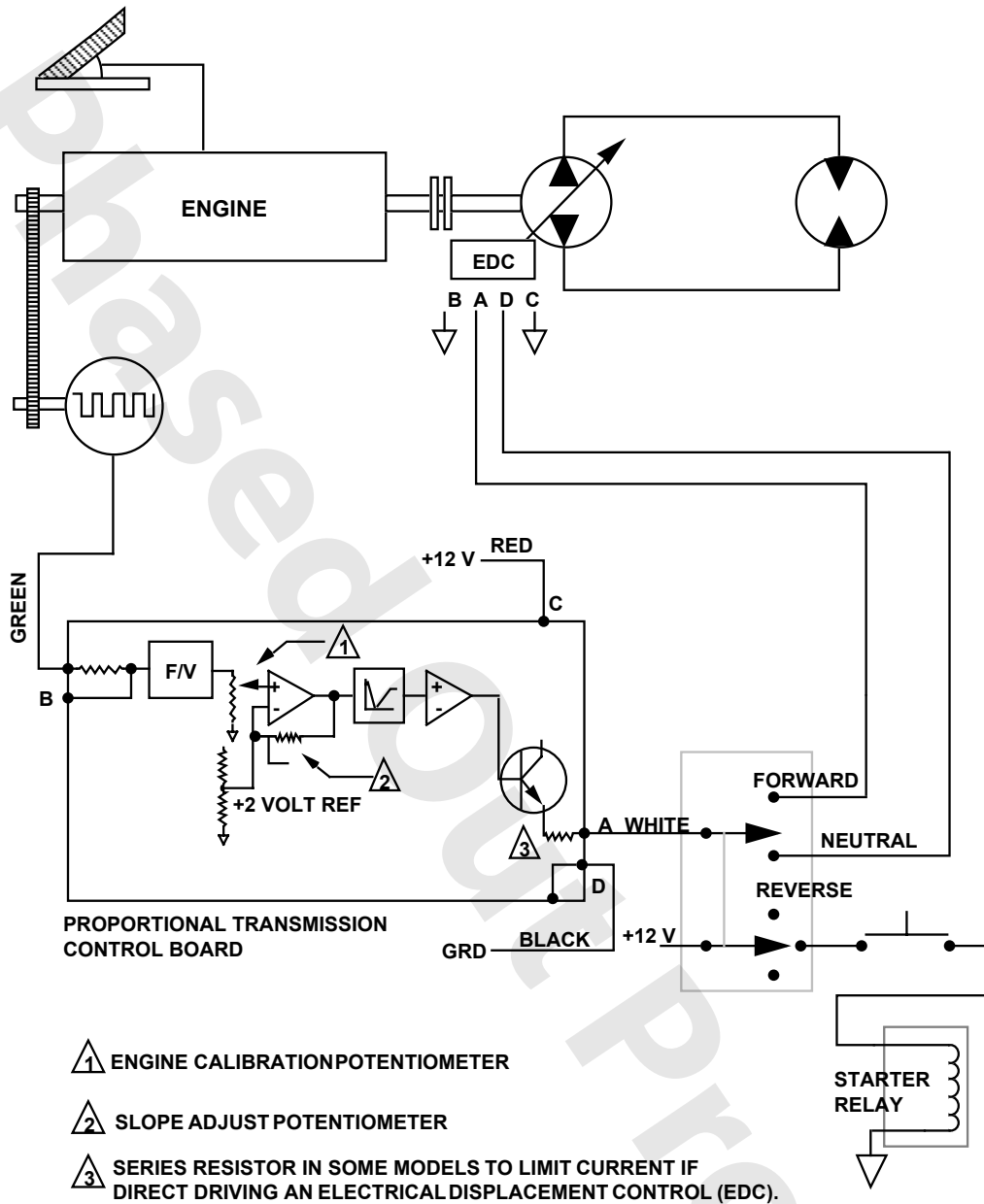

## CONTROLLER OUTPUT Vs. ENGINE RPM

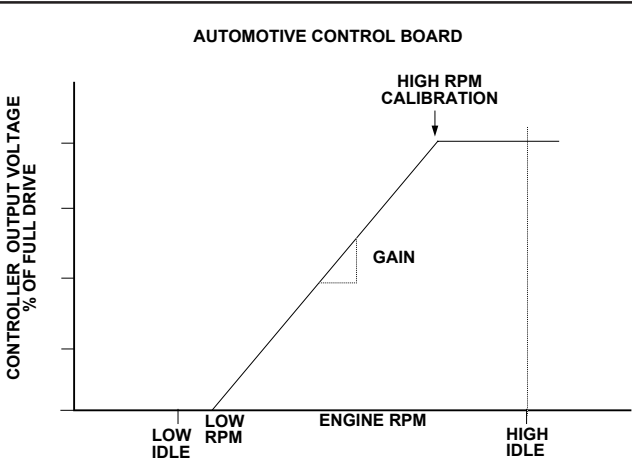

1418

## REVERSE ACTING CONTROLLER

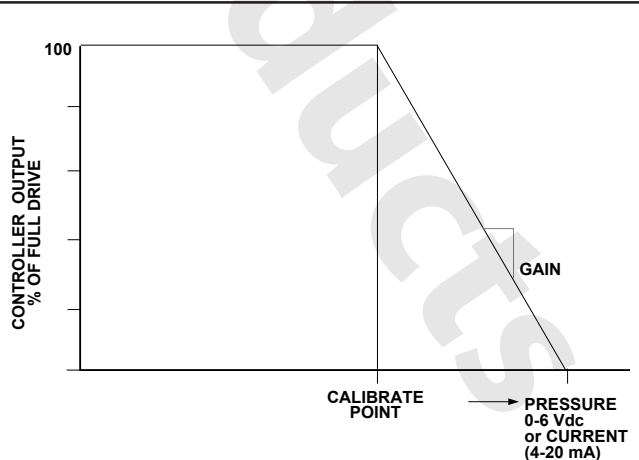

1419

**MCE102A1007 (1014) (1147\*) AUTOMOTIVE**

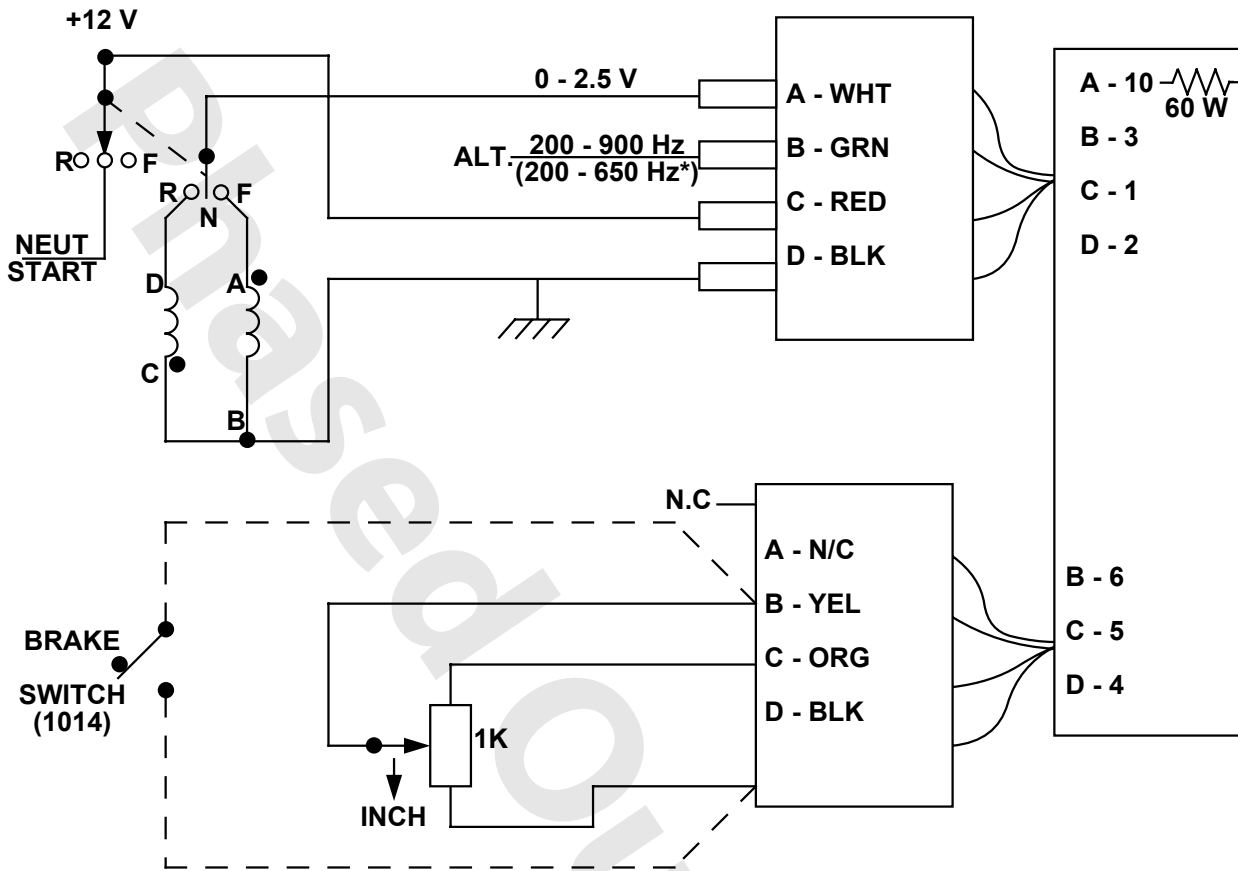

2063

**MCE102A1022 SLAVE RATIO**

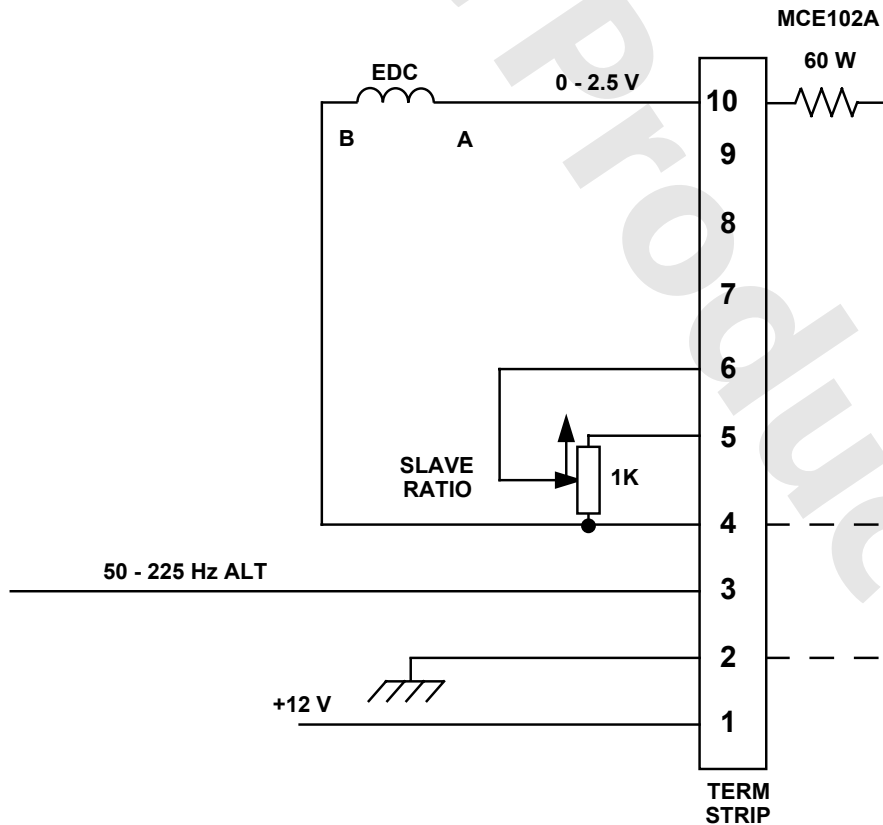

1421

# MCE102A1113 LEAD/LAG FILTER

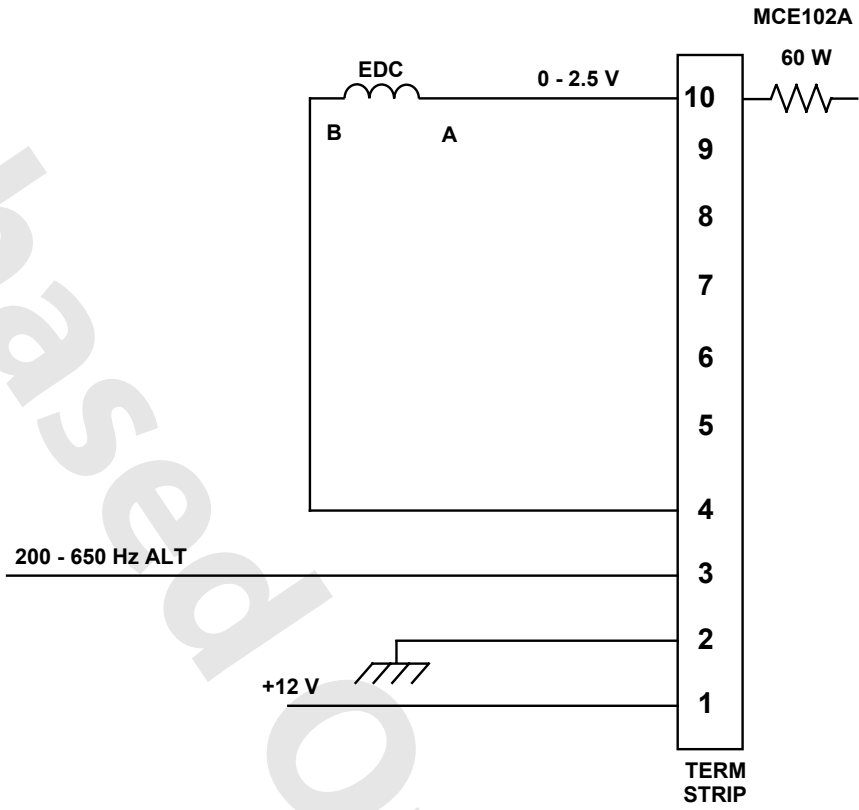

2064

# MCE102A1105 (1139) LEAD/LAG FILTER

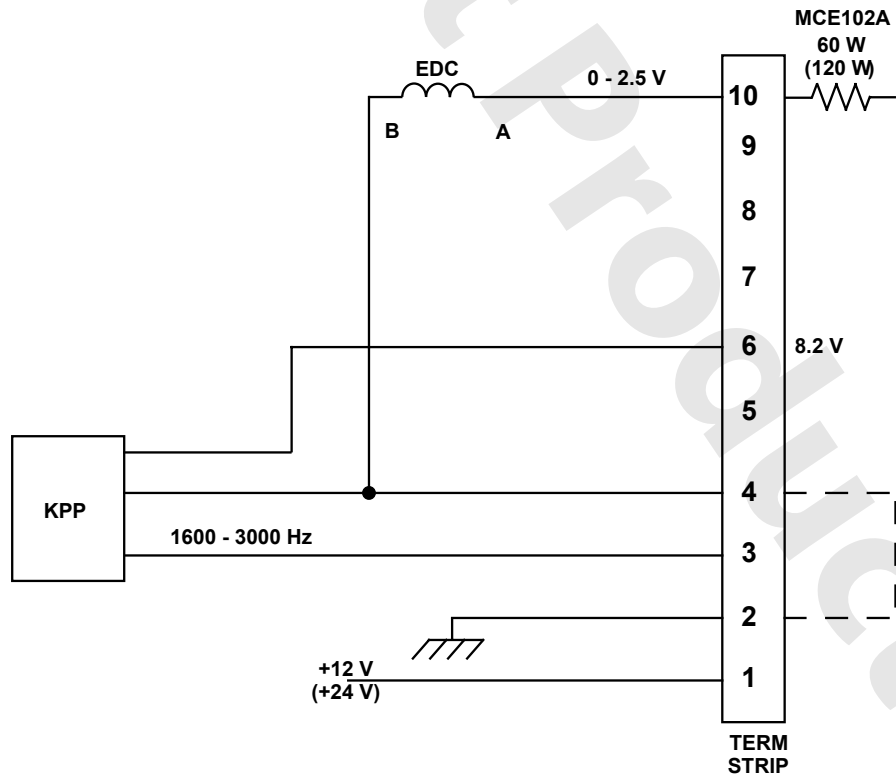

2065

**MCE102A1030 REVERSE ACTING, 24 VOLT, 4 - 20 mA INPUT**

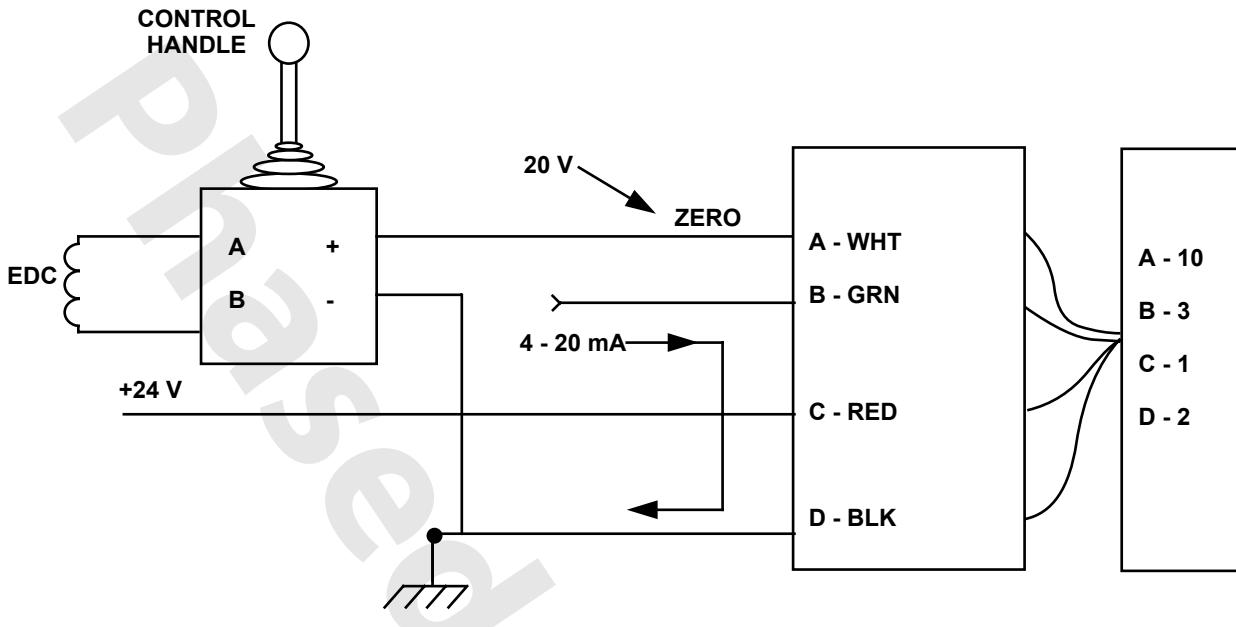

1422A

**MCE102A1097 (1121) WITH LEAD/LAG FILTER**

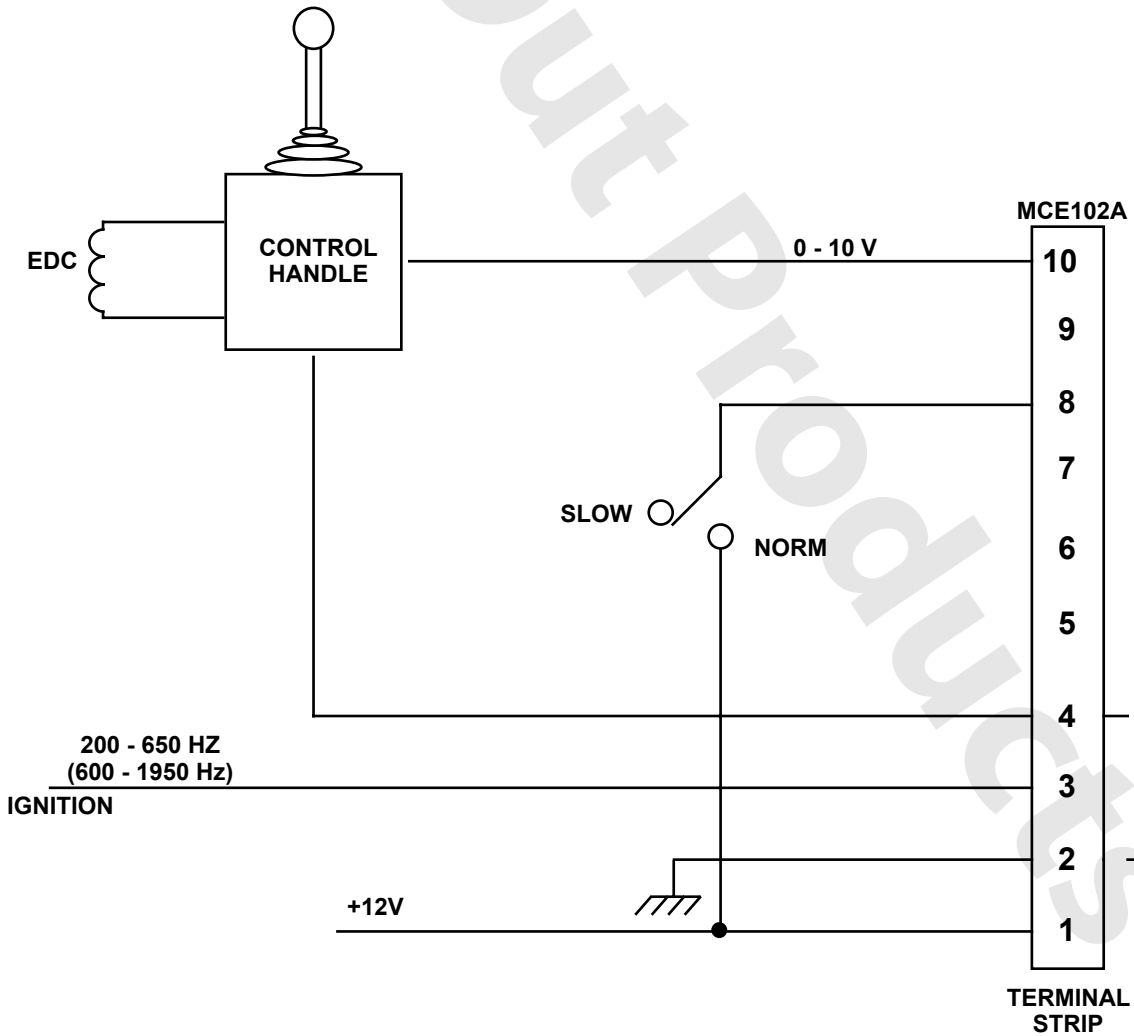

1423

# MCE102A1071 REVERSE ACTING, 24 VOLT, 4 - 20 mA INPUT (TERMINALS)

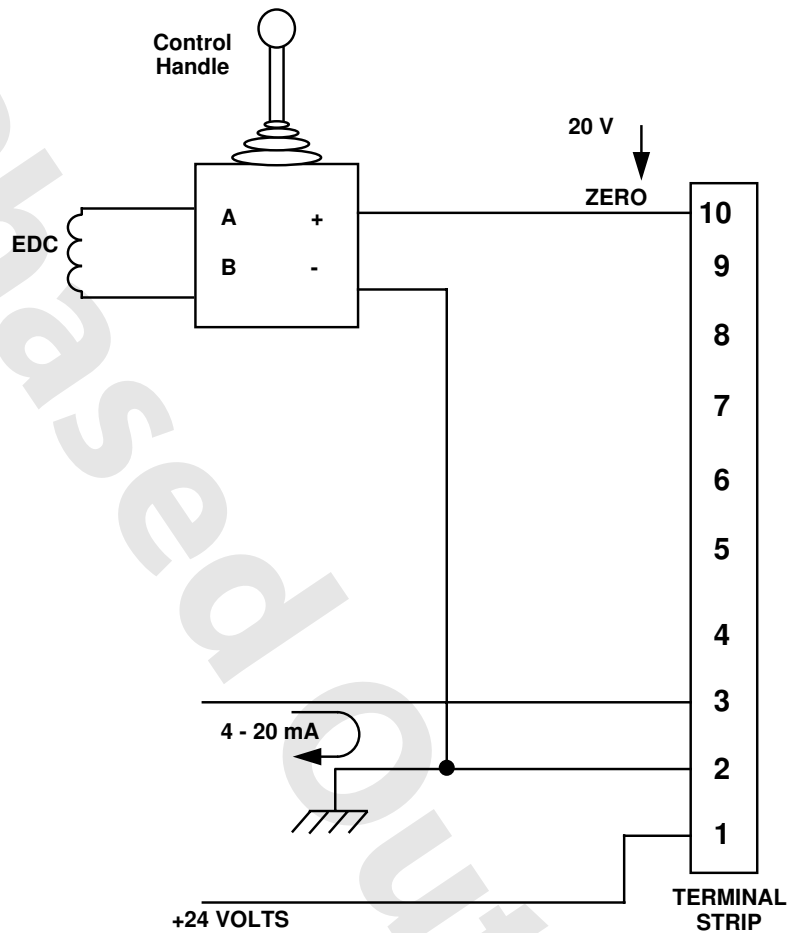

1424

## CUSTOMER SERVICE

### NORTH AMERICA

#### ORDER FROM

Danfoss (US) Company  
Customer Service Department  
3500 Annapolis Lane North  
Minneapolis, Minnesota 55447  
Phone: (763) 509-2084  
Fax: (763) 559-0108

#### DEVICE REPAIR

For devices in need of repair or evaluation, include a description of the problem and what work you believe needs to be done, along with your name, address and telephone number.

### RETURN TO

Danfoss (US) Company  
Return Goods Department  
3500 Annapolis Lane North  
Minneapolis, Minnesota 55447

### EUROPE

#### ORDER FROM

Danfoss (Neumünster) GmbH & Co.  
Order Entry Department  
Krokamp 35  
Postfach 2460  
D-24531 Neumünster  
Germany  
Phone: 49-4321-8710  
Fax: 49-4321-871355