

Technical Information

Sensors

Q625A Remote Setpoint Module

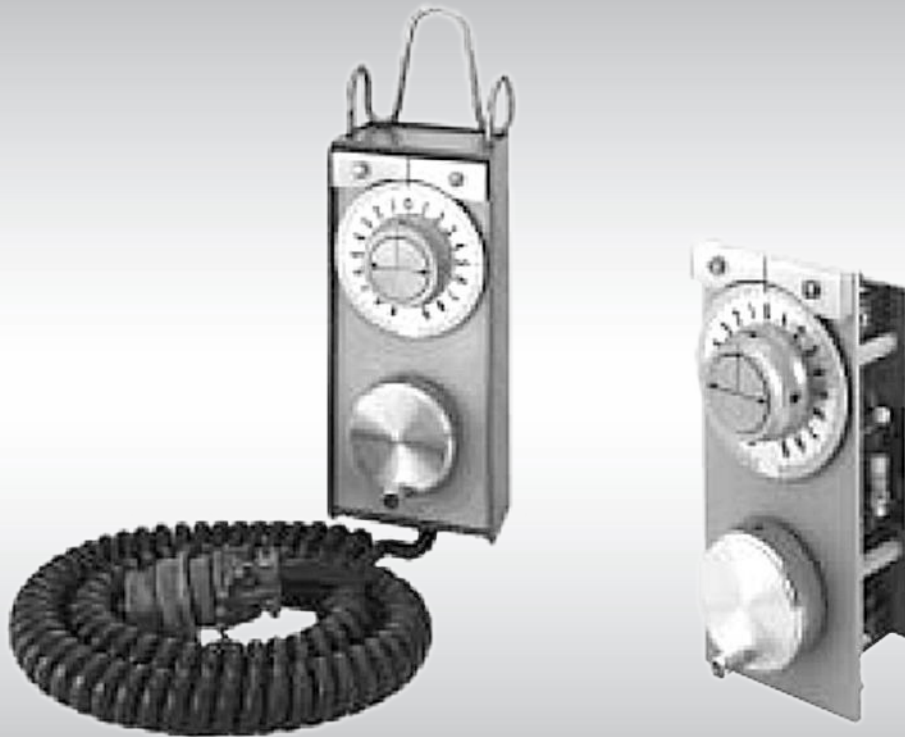

Revision history*Table of revisions*

Date	Changed	Rev
November 2015	Converted to Danfoss layout	0001
September 2010	Initial release (replaces BLN-95-8914)	0000

Contents**Product overview**

Description.....	4
Features.....	4
Ordering information.....	5

Technical data

Performance.....	6
Setpoint range.....	6
Resistance.....	6
Slope roll-off circuit effects.....	6
Centering accuracy.....	6
Hysteresis.....	6
Slope accuracy.....	6
Torque.....	6
Resistance versus dial position.....	7
Environmental.....	7
Weight.....	7

Installation

Hand-held model.....	8
Panel-mount model.....	9
Panel-mount model mounting.....	10
Wiring.....	11
Connection diagram.....	11
Troubleshooting.....	12
Internal workings.....	12

Product overview
Description

1. Hand-Held Model; 2. Panel-Mount Model

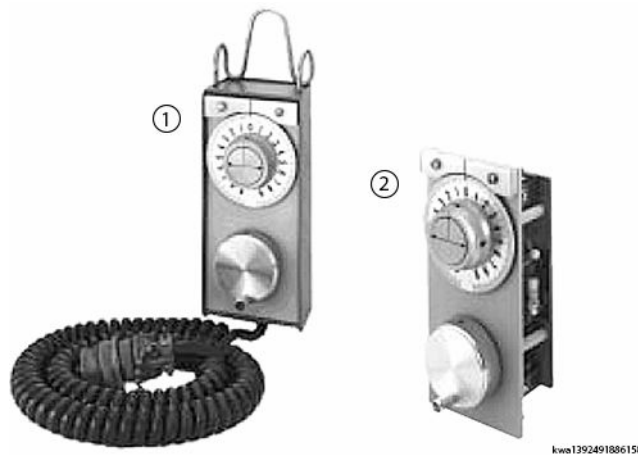

The Q625A remote setpoint is designed for use with the W894A Proportional Level Controller or the R7232A Proportional Indicating Controller. When connected to either controller, the slope setpoint is adjustable to $\pm 9.5\%$ slope. Two models of the Q625A are available. The hand-held version has a coiled cord and MS connector for hook up. A panel-mount version mounts in a panel and provides a terminal strip for hook-up. Both Q625A models are available with a slope roll-off circuit, which functions as a filter to reduce gain at frequencies above 3 Hz, for use on equipment with high vibration and shock levels.

Features

- Spring-Loaded Hanger
 - Hand-held model easily clips to railing, pipes, bars, etc., to permit extensive freedom of movement for the operator about the machine.
- Adjustable Dial
 - Clutch in the dial permits adjustment of the dial with respect to the potentiometer. With this feature, the zero can be used as a reference for any off level condition.
- Optional Slope Roll-Off Circuit
 - High mechanical vibration and shock levels of the machine are effectively shunted by the roll-off circuit to prevent system reaction initiated by the highly sensitive slope sensor.
- Slip Clutch
 - Prevents damage to the potentiometer when the end of travel is reached.
- Rugged Aluminum Housing
 - Shock and vibration resistant. Mounts in any orientation without affecting operation. Resists corrosion, moisture, and other damaging environmental effects.
- Easy To Install
 - MS connector on hand-held model plugs in and screws tight. Four connections to terminal strip on panel-mount model; mounts on a flat surface 76.2 mm by 152.4 mm (3 by 6 in) or larger.
- High Resolution
 - Gear train provides a reduction between the setpoint crank and the read-out dial. One complete turn of the crank changes the setpoint by 0.1% slope.

Technical Information Q625A Remote Setpoint Module

Product overview
Ordering information
Specifications

Part number	Description	Specify
Q625A	Remote setpoint	Panel-mount or hand-held
		Slope roll-off (optional)

Accessory for Panel-Mount Model

Part number	Description
KW01001*	Cable assembly

* The kit (part number KW01001) provides all necessary wiring connections between the panel-mount Q625A and the R7232A with MS connectors or the W894A. The cable comes completely assembled with MS connector on one end; spade lugs on the other end.

Replacement part for Hand-Held Model

Part number	Description
K04034	Cable with mating MS connector

Technical data
Performance
Setpoint range

Adjustable to $\pm 9.5\%$ slope. One revolution of the crank changes the setpoint 0.1% slope.

Resistance

2500 \pm 5 ohms between A and C of the connector or terminal strip. Resistance between A and B increases when the hand crank is rotated clockwise. See [Resistance versus dial position](#) on page 7.

Slope roll-off circuit effects

The slope roll-off circuit acts as a filter to reduce slope system gain by 14 db at mechanical vibration frequencies above 3 Hz.

Centering accuracy

Potentiometer centering to dial zero position will be accurate to within $\pm 0.10\%$.

Hysteresis

The hand crank to dial hysteresis including back-lash will be less than 0.08% slope.

Slope accuracy

After adjusting the zero dial setting to coincide with the electrical midpoint of the device, the accuracy at any dial setting within $\pm 5\%$ slope shall be within $\pm 0.14\%$ of absolute slope. Accuracy outside of $\pm 5\%$ slope will be within $\pm 0.20\%$ of absolute slope.

Torque

Dial torque	15 + 5-9 in. - oz. (0.1059 + 0.035-0.063 Nm)
Crank torque	8 \pm 6 in. - oz. (0.056 \pm 0.042 Nm)

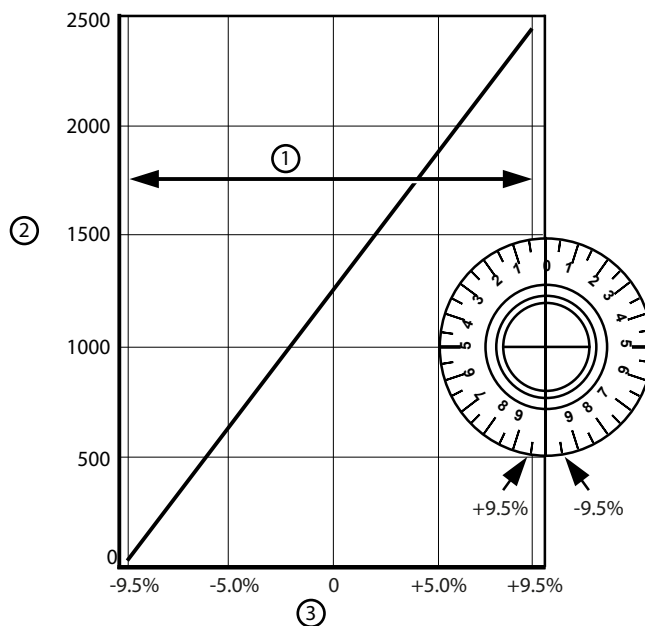
Technical data
Resistance versus dial position

kwa1392491897910

- 1 Setpoint range
- 2 Resistance between pins/terminals A and B in ohms
- 3 Dial indication

Environmental
Vibration

Withstands a vibration test designed for mobile equipment devices that includes two parts:

1. Cycling from 5 to 2000 Hz over a range of +1.5 g to +3.0 g. The cycling test is performed on each of the three major axes.
2. Resonance dwell for one million cycles over a range of +1.5 g to +3.0 g for each of the three major axes. Acceleration level varies with frequency.

Shock

Withstands a shock test for mobile equipment devices that consists of three shocks of 50 g and 11 ms duration in both directions of the three major axes for a total of 18 shocks.

Temperature

Operating temperature	-18° to 60° C (0° to 140° F)
Storage temperature	-40° to 77° C (-40° to + 170° F)

Weight

Hand-held model	0.98 kg (2.18 lbs)
Panel-mount model	0.51 kg (1.125 lbs)

Installation

Hand-held model

Hand-held Q625A does not require mounting due to a spring-return hanger design for suspending the remote setpoint in any convenient location.

Hand-held model mounting dimensions in millimeters [inches]

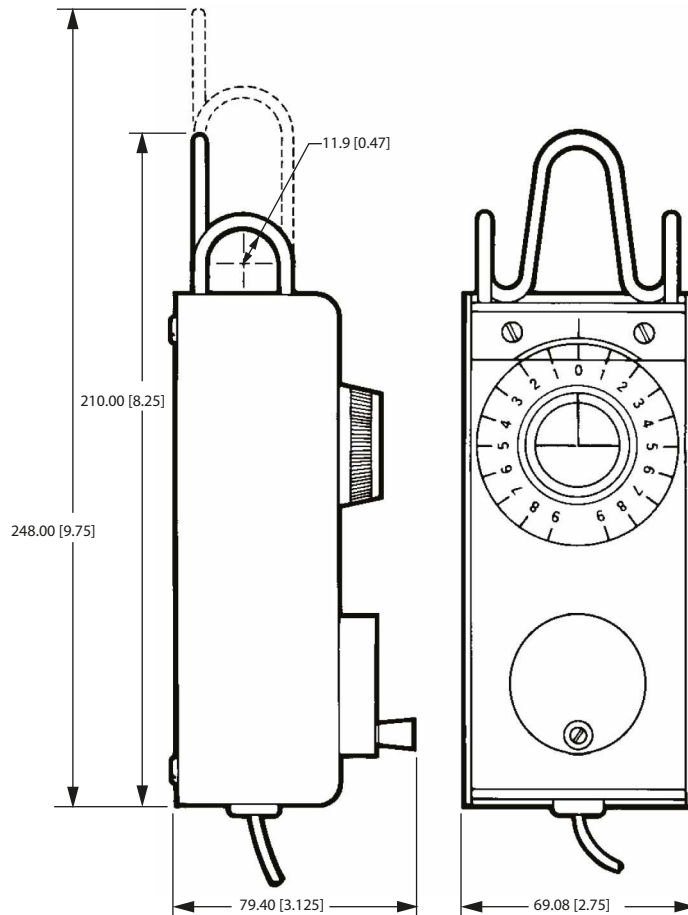

kwa1392491912407

Installation
Panel-mount model

Panel-mount Q625A requires clearance holes. Reference [Panel-mount model mounting](#) on page 10. Clearance behind the panel for the device should be at least 50.80 mm (2.00 in).

1. Drill 4.763 mm (3/16 in) clearance holes.
2. Remove the nuts from the threaded studs at the back of the front plate.
3. Insert the studs through the clearance holes.
4. Replace the nuts from the back of the panel.

Panel-mount model mounting dimensions in millimeters [inches]

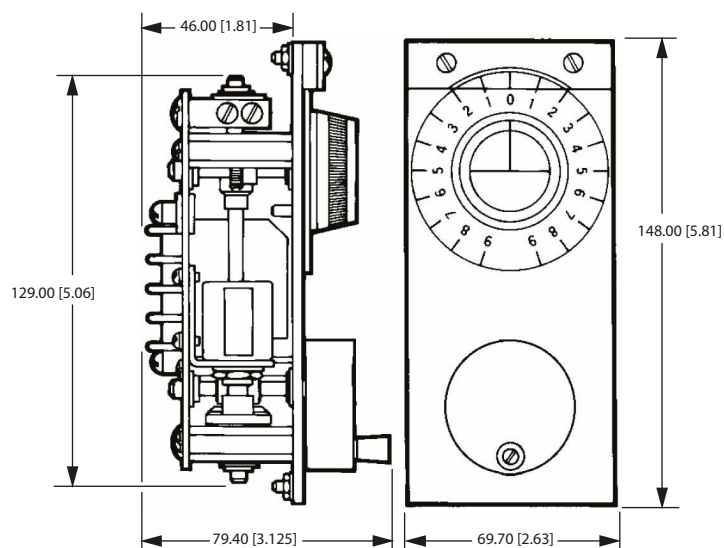

kwa1392491917135

Installation

Panel-mount model mounting

Panel cut-out dimensions and mounting holes locations in millimeter [inches]

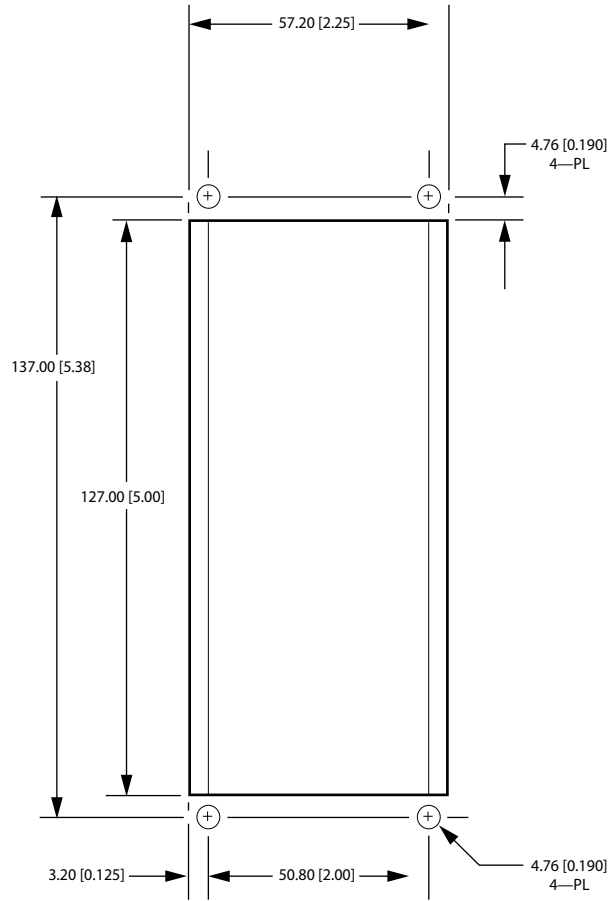

kwa1392491923871

Installation

Wiring

Hand-held model

Hand-held Q625A has an integral 0.610 mm (2.00 ft) coiled cable with an MS connector that plugs directly into the R7232A or W894A.

If an R7232A with terminal strips is to be used in conjunction with the hand-held Q625A, connect the amplifier to a Bendix MS3102A16S-8P receptacle (Danfoss part number K03992). Wire the receptacle to the corresponding letters on the R7232A terminal strip, and mount to panel, reference [Connection diagram](#) on page 11.

Panel-mount model

Panel-mount Q625A has terminal strips for wiring connections, reference [Connection diagram](#) on page 11.

If an R7232A with MS connectors or W894A is to be used in conjunction with the panel-mount Q625A, order cable assembly (Danfoss part number KW01001). The cable assembly includes spade lugs at one end and an MS connector at the other end to provide all necessary wiring for the panel-mount Q625A.

Connection diagram

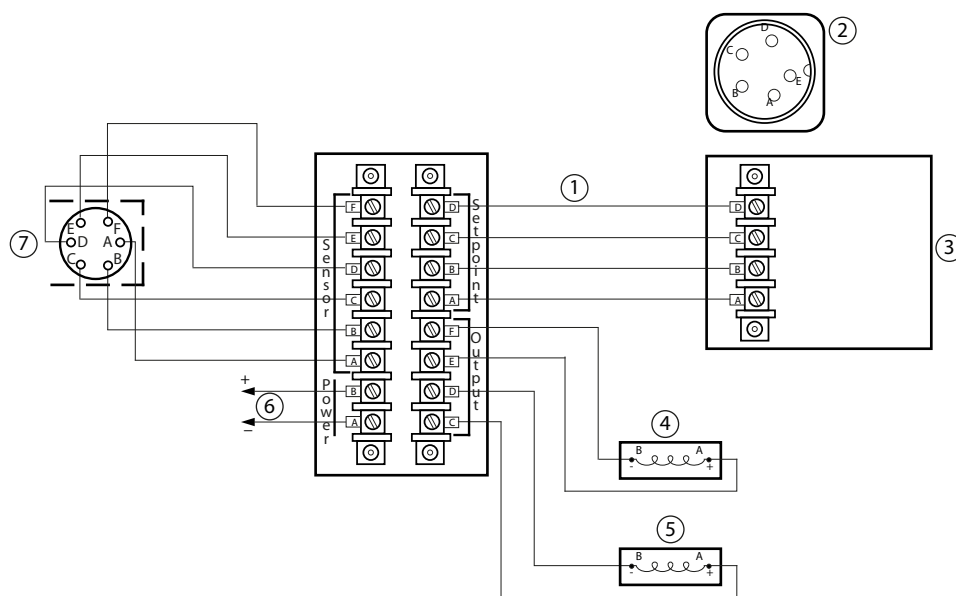

kwa1392491930733

Callout	Description	Comment
1	Wiring D to D	Wiring from D to D is needed only where the remote setpoint is equipped with a roll-off circuit.
2	Bendix type MS3102A16S-8P connector (Danfoss part number K03992)	If a hand-held remote setpoint Q625A is used, connect the amplifier to a Bendix type MS3102A16S-8P, A, B, C, D to A, B, C, D respectively and mount on the panel.
3	Q625A panel mount remote setpoint	
4	MCV113 servovalve for level control	The R7232 will operate one MCV113 servovalve for either rotary position or level control, but not both at the same time.
5	MCV113 servovalve for rotary position control	
6	11 to 15 Vdc input	
7	SB104 or KS10201 sensor	

Installation

Troubleshooting

The Q625A will provide extended, trouble free operation and should not need servicing under normal operating conditions. Be sure the Q625A is malfunctioning before replacing it.

1. Check all wires looking for cuts or evidence of pinching.
2. Check if connector spade lugs have been disconnected.
3. If a VOM is available, check resistance between Pins/Terminals A and C for 2500 ohms or 9400 ohms, depending on model. Check continuity between Pins/Terminals A and B, and B and C while rotating the hand crank.

Resistance should approximate the values shown in the [Resistance versus dial position](#) on page 7 drawing and reference [Internal workings](#) on page 12.

4. Reduce sensitivity or gain of the controller to eliminate oscillation.

If the Q625A has a slope roll-off circuit and the equipment or machine control appears to be unstable or oscillates, the roll-off circuit may be at fault.

5. If a VOM is available, check the slope roll-off circuit (reference [Internal workings](#) on page 12).

- a) Place the output leads of the VOM across Pins/ Terminals B and D of the MS connector or terminal strip.

A reading of 1500 ohms should be found on the R x 100 scale. If the capacitor is shorted the VOM will read 500 ohms.

- b) Switch the VOM to the R x 10,000 scale. Reverse polarity on the VOM.

Charging of the capacitor should be seen on the meter.

6. If another Q625A is available, connect it in place of the existing one.

- a) Change the slope setpoint and observe operation.

If the replacement Q625A corrects the malfunction, replace the original unit.

7. Check if servovalve, controller, and sensor are operating.

Internal workings

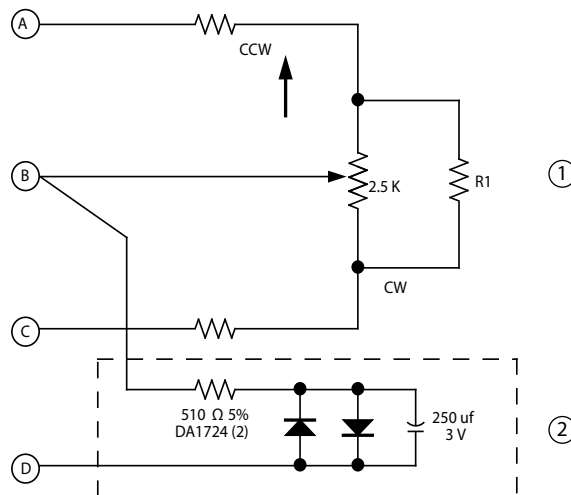

kwa1392491938844

1. Resistor R1 is a high resistance value selected to increase the accuracy of the potentiometer.
2. Roll-off circuit (roll-off is optional)



Products we offer:

- Bent Axis Motors
- Closed Circuit Axial Piston Pumps and Motors
- Displays
- Electrohydraulic Power Steering
- Electrohydraulics
- Hydraulic Power Steering
- Integrated Systems
- Joysticks and Control Handles
- Microcontrollers and Software
- Open Circuit Axial Piston Pumps
- Orbital Motors
- PLUS+1® GUIDE
- Proportional Valves
- Sensors
- Steering
- Transit Mixer Drives

Danfoss Power Solutions is a global manufacturer and supplier of high-quality hydraulic and electronic components. We specialize in providing state-of-the-art technology and solutions that excel in the harsh operating conditions of the mobile off-highway market. Building on our extensive applications expertise, we work closely with our customers to ensure exceptional performance for a broad range of off-highway vehicles.

We help OEMs around the world speed up system development, reduce costs and bring vehicles to market faster.

Danfoss – Your Strongest Partner in Mobile Hydraulics.

Go to www.powersolutions.danfoss.com for further product information.

Wherever off-highway vehicles are at work, so is Danfoss. We offer expert worldwide support for our customers, ensuring the best possible solutions for outstanding performance. And with an extensive network of Global Service Partners, we also provide comprehensive global service for all of our components.

Please contact the Danfoss Power Solution representative nearest you.

Comatrol

www.comatrol.com

Schwarzmueller-Inverter

www.schwarzmueller-inverter.com

Turolla

www.turollaocg.com

Hydro-Gear

www.hydro-gear.com

Daikin-Sauer-Danfoss

www.daikin-sauer-danfoss.com

Local address:

Danfoss Power Solutions (US) Company
2800 East 13th Street
Ames, IA 50010, USA
Phone: +1 515 239 6000

Danfoss Power Solutions GmbH & Co. OHG
Krokamp 35
D-24539 Neumünster, Germany
Phone: +49 4321 871 0

Danfoss Power Solutions ApS
Nordborgvej 81
DK-6430 Nordborg, Denmark
Phone: +45 7488 2222

Danfoss Power Solutions Trading (Shanghai) Co., Ltd.
Building #22, No. 1000 Jin Hai Rd
Jin Qiao, Pudong New District
Shanghai, China 201206
Phone: +86 21 3418 5200

Danfoss can accept no responsibility for possible errors in catalogues, brochures and other printed material. Danfoss reserves the right to alter its products without notice. This also applies to products already on order provided that such alterations can be made without changes being necessary in specifications already agreed. All trademarks in this material are property of the respective companies. Danfoss and the Danfoss logotype are trademarks of Danfoss A/S. All rights reserved.