

**RA 2000 1PS
Thermostatic Radiator Valve
For Use on One-Pipe Low-Pressure
Steam Systems**



**Typical
Installation:**

Dial / Operator / Sensor + Valve

FREE STANDING RADIATORS

The free-standing one-pipe low-pressure steam radiator is positioned where air continually passes freely over the operator

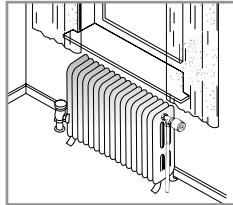

Use standard or tamper resistant model with combined dial/operator/sensor. Always install the operator horizontally

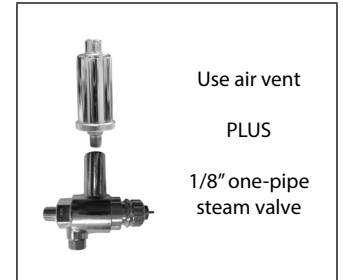

FREE STANDING RADIATORS

The free-standing one-pipe low-pressure steam radiator is accessible, but due to obstruction air cannot continually pass freely over the operator

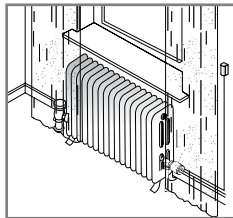

Use dial / operator with remote sensor. The sensor and capillary tube may be extended up to 6' and can be easily wall mounted.

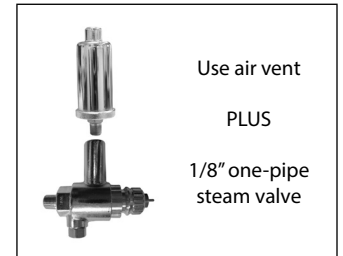

CONVECTORS

The one-pipe low-pressure steam convector is inaccessible; room air cannot continually pass freely over the sensing element

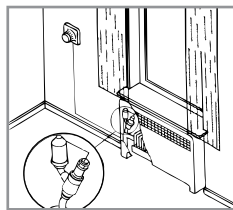

Use operator with combined remote dial / sensor. The dial/sensor and capillary tube may be extended up to 6' and are wall mounted.

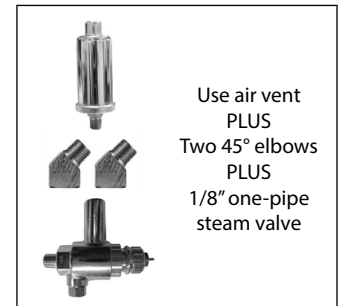

ENCLOSED RADIATORS

The cabinet enclosed radiator configuration requires that the dial and sensor be mounted separately, away from the valve

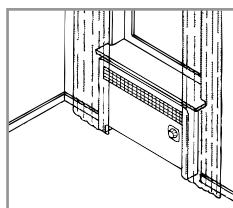

Use operator with separate remote dial and remote sensor. Place the remote sensor on a draft-free wall. The remote dial mounts on the enclosure or wall.

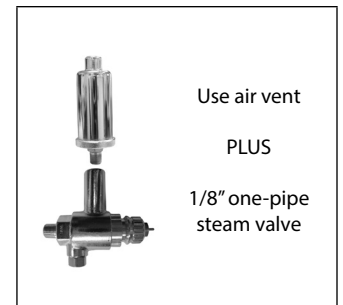

RA 2000 1PS
Thermostatic Radiator Valve
For Use on One-Pipe Low-Pressure
Steam Systems



Design & Function:

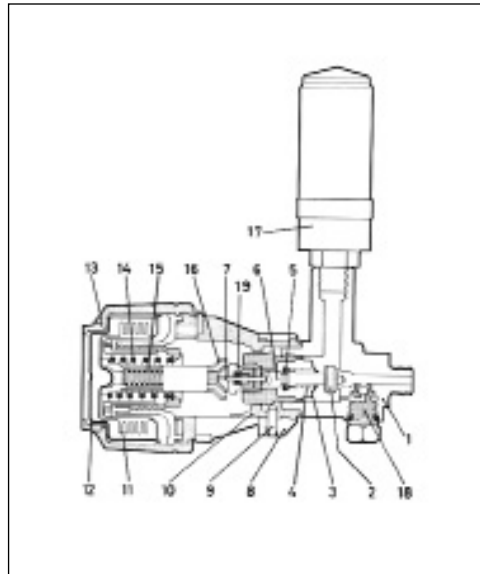

Part	Material
1. Valve	Nicel plated brass
2. Valve disc	EPDM
3. Spindle guide	Phosphor bronze
4. Spring	Stainless Steel
5. Back seat washer	EPDM
6. Valve Spindle	Brass
7. Pressure pin	Stainless steel
8. Clamping band	Al. alloy
9. Allenscrew	Steel
10. Socket	Zytel Nylon
11. Bellows	Phosphor bronze
12. Handle	ABS
13. Adjustment spring	Steel
14. Safety spring	Steel
15. Pressure spindle	Polymide No. 6
16. Air vent	-
17. Retainer	Brass
18. Packing gland	-
19. Capillary Tube	Steel

- Danfoss' RA 2000 1PS one-pipe steam thermostatic radiator valve provides accurate temperature control and quiet operation.
- The movement of air across the thermostatic operator effects the modulation control in regulating the venting of air from the radiator or convector.
- Based on the set temperature on the operator, the 1PS regulates the amount of steam allowed into the emitter by controlling the amount of air allowed to vent out.
- The venting action occurs during each system (boiler) on-cycle only when heat

is required. Air will re-enter the system during the boiler off-cycle via a patented "across the seat" vacuum breaker. This eliminates condensate buildup and allows natural system aspiration to take place.

- The RA 2000 1PS assembly is specifically designed for low pressure steam systems. The system pressure should not be constant preventing air to get back into the system.
- Thermostatic radiator valve assembly- valve, thermostatic operator and air vent- can be used for free standing radiators, convectors, and enclosed radiators. 1PS is not recommended for copper fin tube radiators.

Dimensions:

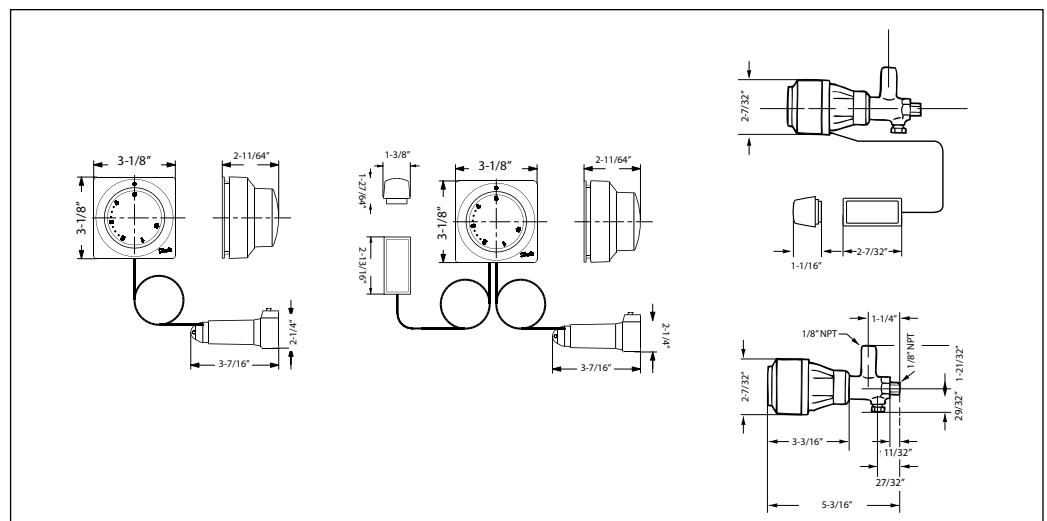

**RA 2000 1PS
Thermostatic Radiator Valve
For Use on One-Pipe Low-Pressure
Steam Systems**



Technical Data:

Type	Maximum Temperature	Maximum Pressure
RA 2000 1PS	250°F (121°C)	15psig

RA 2000 Operators:

Operator	Code No.	Description	Sensor	Capillary
	013G8250	Valve mounted dial & sensor	Built-in	-
	013G8252	Valve mounted dial with remote sensor	Remote	6'
	013G8240	Valve mounted dial and sensor, tamper resistant	Built-in	-
	013G2922	Valve mounted dial with remote sensor tamper resistant	Remote	6'
	013G8562	Combined remote mounted dial & sensor	-	6'
	013G8565	Combined remote mounted dial & sensor	-	16'
	013G8568	Combined remote mounted dial & sensor	-	26'
	013G8564	Separate remote mounted dial and sensor	Remote	6' + 6'

**Parts and Accessories
For RA 2000 Operators:**

013G8250
013G8252
013G8240
013G2922

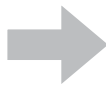

Code No.	Description
013G1236	Screwdriver tool set for RA 8240 / 2922
013G1215	Limitation pins for RA 8250/52 (30 pcs)
013G1237	Limitation pins for tamper resistant operators RA 8240 / 2922 (30 pcs)
013G5245	Anti-theft protection clips for RA 8250/52 (20 pcs)
013G1232	Locking screw plugs for tamper resistant operators RA 8240 / 2922 (50 pcs).
013G1672	Cover plate for setting Window of tamper resistant operators (20 pcs)

013G8562
013G8565
013G8568
013G2564



	Code No.	Description	Position No.
	013G5191	Socket Body for RA 2000	1
	013G5503	Bellows Holder (set of 2 pcs)	2

RA 2000 1PS Valve :

Design	Code No.	Valve size	Pattern	Connection Inlet x Outlet
	013G0140	1/8"	1PS	MPT x FTP

**RA 2000 1PS
Thermostatic Radiator Valve
For Use on One-Pipe Low-Pressure
Steam Systems**



**Parts and Accessories
For RA 2000 1PS Valve :**

Code No.	Description
013L8011	1-Pipe steam air vent
013L8300	Brass 45° street elbow for convector, for space consideration
013G0290	Packing gland for valves

How to avoid problems:

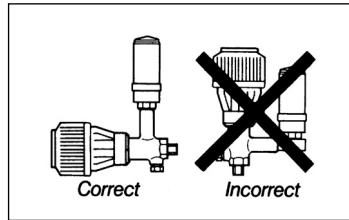

The operator with valve-mounted dial and sensor must be mounted horizontally.

IMPORTANT

In one-pipe steam systems sufficient pitch is required to permit condensate return. Condensate should not be trapped in the valve or vent. The vent (when not supplied) should be checked to assure it is properly working.

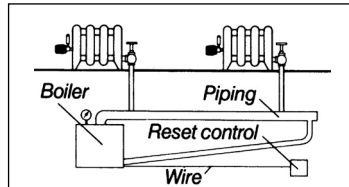

Boiler/steam supply must not run at constant pressure. This prevents the ability for air to enter back into the system.

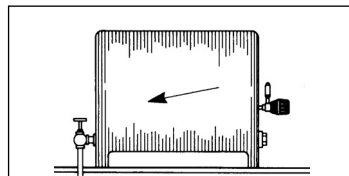

Make sure that free-standing radiators or cast iron convectors are properly pitched and that hand valves are FULLY open.

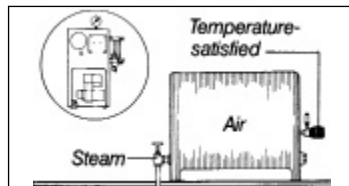

To aid in preventing overheating of rooms that are temperature satisfied, boiler steam pressure must be kept low, recommended normally at or below 2psig. Otherwise air will be compressed in the radiator, allowing steam to enter when not required.

Setting:



The user can easily set room temperature by turning the dial clockwise or counterclockwise. The diagram to the right shows the appropriate relationship between dial scale numbers and room temperature.

temperature at approximately 45°F (7°C). At its highest setting, the RA 2000 1PS maintains room temperature at approximately 85°F (30°C).

At its lowest setting, the RA 2000 1PS provides frost protection and maintains room

The temperature on all RA 2000 1PS models may be limited or locked.

Danfoss can accept no responsibility for possible errors in printed materials and reserves the right to alter its products without notice. All trademarks in this material are property of the respective companies. Danfoss and Danfoss logotype are trademarks of Danfoss A/S. All rights reserved.



Danfoss
Toronto, ON
Tel.: 866-372-4822, Fax: 416-352-5981
www.heating.danfoss.us

Danfoss
Baltimore, MD
Tel.: 866-372-4822, Fax: 416-352-5981
www.heating.danfoss.us