

BD250/250GH Direct Current Twin Compressor R134a, 12-24V

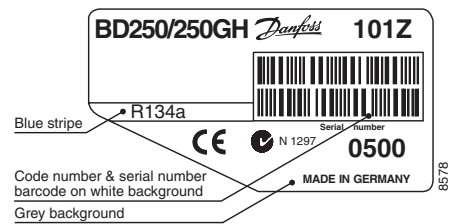

General

Code number (without electronic units)	101Z0500
Electronic unit (with integrated fan cooling, 2 pcs. required)	single: 101N0290, 28 pcs: 101N0291
Remote kit (2 pcs. required)	105N9210 (without cable)
Approved compressor - electronic unit combinations	refer to <i>Technical Info</i> DEHC.EI.100.C
Additional approvals	e4, CE, C-Tick
Compressors on pallet	40



Application

Application		LBP/MBP/HBP
Evaporating temperature	°C	-25 to 15
Voltage range/max. voltage	VDC	12-24/31.5
Max. condensing temperature continuous (short)	°C	60 (70)
Max. winding temperature continuous (short)	°C	125 (135)

Cooling requirements

Application	LBP	MBP	HBP
32°C	S	S	S
38°C	S	S	S
43°C	S	S	S
Remarks on application:			

- S = Static cooling normally sufficient
- O = Oil cooling
- F₁ = Fan cooling 1.5 m/s
(compressor compartment temperature equal to ambient temperature)
- F₂ = Fan cooling 3.0 m/s necessary
- SG = Suction gas cooling normally sufficient
- = not applicable in this area

Motor

Motor type		Variable speed
Resistance, all 3 windings (25°C)	Ω	1.8

Design

Displacement	cm ³	2 x 2.50
Oil quantity (type)	cm ³	400 (polyolester)
Maximum refrigerant charge	g	600
Free gas volume in compressor	cm ³	2 x 870
Weight - Compressor/Electronic unit	kg	8.8/2 x 0.3

Dimensions

Height	mm	A	137
		B	135
		B1	128
		B2	73
Suction connector	location/I.D. mm angle	C	6.2 41.5°
Process connector	location/I.D. mm angle	D	6.2 45°
Discharge connector	location/I.D. mm angle	E	5.0 21°
Connector tolerance	I.D. mm		±0.09, on 5.0 +0.12/+0.20

Standard battery protection settings (no connection C - P)

12V cut-out [V]	12V cut-in [V]	24V cut-out [V]	24V cut-in [V]
10.4	11.7	22.8	24.2

Optional battery protections settings

Resistor (R2)	12V cut-out	12V cut-in	12V max.	24V cut-out	24V cut-in	24V max.
[kΩ]	[V]	[V]	Voltage [V]	[V]	[V]	Voltage [V]
0	9.6	10.9	17.0	21.3	22.7	31.5
1.6	9.7	11.0	17.0	21.5	22.9	31.5
2.4	9.9	11.1	17.0	21.8	23.2	31.5
3.6	10.0	11.3	17.0	22.0	23.4	31.5
4.7	10.1	11.4	17.0	22.3	23.7	31.5
6.2	10.2	11.5	17.0	22.5	23.9	31.5
8.2	10.4	11.7	17.0	22.8	24.2	31.5
11	10.5	11.8	17.0	23.0	24.5	31.5
14	10.6	11.9	17.0	23.3	24.7	31.5
18	10.8	12.0	17.0	23.6	25.0	31.5
24	10.9	12.2	17.0	23.8	25.2	31.5
33	11.0	12.3	17.0	24.1	25.5	31.5
47	11.1	12.4	17.0	24.3	25.7	31.5
82	11.3	12.5	17.0	24.6	26.0	31.5
220	9.6	10.9				31.5

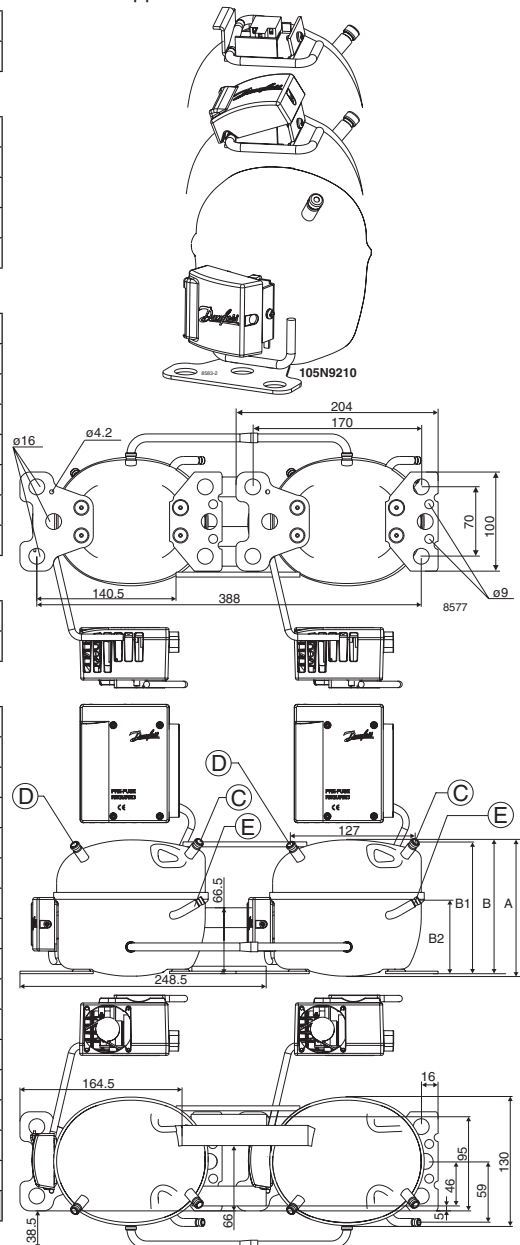

Capacity (EN 12900 Household/CECOMAF)

rpm \ °C	12V DC static cooling watt											
	-25	-23.3	-20	-15	-10	-6.7	-5	0	5	7.2	10	15
2,500	76.0	85.1	105	139	181	213	231	290	358	392	438	529
3,100	92.5	103	126	168	217	255	277	347	429	469	524	633
3,800	112	125	153	203	262	308	333	417	514	562	627	757
4,400	126	141	174	231	299	349	378	471	580	633	705	849

Capacity (ASHRAE LBP)

rpm \ °C	12V DC static cooling watt											
	-25	-23.3	-20	-15	-10	-6.7	-5	0	5	7.2	10	15
2,500	94.0	105	129	172	224	264	286	359	444	486	544	658
3,100	114	128	156	207	269	316	343	430	532	582	651	787
3,800	138	155	189	251	325	381	413	517	638	698	779	942
4,400	156	175	216	286	370	433	468	584	719	785	876	1057

Power consumption

rpm \ °C	12V DC static cooling watt											
	-25	-23.3	-20	-15	-10	-6.7	-5	0	5	7.2	10	15
2,500	81.5	86.9	97.8	115	134	146	152	171	189	197	207	224
3,100	102	108	121	141	163	179	187	211	237	248	263	291
3,800	126	134	150	176	203	222	233	265	300	316	338	380
4,400	145	155	175	206	239	263	275	314	358	379	406*	460*

Current consumption (for 24V applications the following must be halved)

rpm \ °C	12V DC static cooling A											
	-25	-23.3	-20	-15	-10	-6.7	-5	0	5	7.2	10	15
2,500	6.79	7.24	8.15	9.61	11.12	12.15	12.68	14.24	15.79	16.45	17.28	18.69
3,100	8.46	8.99	10.07	11.79	13.61	14.88	15.54	17.58	19.71	20.68	21.93	24.25
3,800	10.51	11.18	12.52	14.65	16.94	18.54	19.40	22.07	24.99	26.35	28.17	31.66
4,400	12.11	12.95	14.60	17.19	19.94	21.88	22.93	26.20	29.82	31.54	33.85	38.35

COP (EN 12900 Household/CECOMAF)

rpm \ °C	12V DC static cooling W/W											
	-25	-23.3	-20	-15	-10	-6.7	-5	0	5	7.2	10	15
2,500	0.93	0.98	1.07	1.21	1.36	1.46	1.52	1.69	1.89	1.98	2.11	2.36
3,100	0.91	0.96	1.05	1.18	1.33	1.43	1.48	1.64	1.81	1.89	1.99	2.17
3,800	0.89	0.93	1.02	1.15	1.29	1.38	1.43	1.57	1.72	1.78	1.86	1.99
4,400	0.87	0.91	0.99	1.12	1.25	1.33	1.37	1.50	1.62	1.67	1.74	1.85

COP (ASHRAE LBP)

rpm \ °C	12V DC static cooling W/W											
	-25	-23.3	-20	-15	-10	-6.7	-5	0	5	7.2	10	15
2,500	1.16	1.21	1.33	1.50	1.68	1.82	1.89	2.11	2.36	2.48	2.64	2.96
3,100	1.13	1.18	1.30	1.47	1.65	1.78	1.85	2.05	2.26	2.36	2.49	2.73
3,800	1.10	1.15	1.26	1.43	1.60	1.72	1.78	1.96	2.14	2.22	2.32	2.50
4,400	1.07	1.13	1.23	1.39	1.55	1.65	1.71	1.87	2.02	2.09	2.17	2.31

* Possible thermal cut-out of electronic unit due to heavy loaded refrigeration system.

Operational errors shown by LED (optional)

Number of flashes	Error type
5	Thermal cut-out of electronic unit (If the refrigeration system has been too heavily loaded, or if the ambient temperature is high, the electronic unit will run too hot).
4	Minimum motor speed error (If the refrigeration system is too heavily loaded, the motor cannot maintain minimum speed at approximately 2,450 rpm).
3	Motor start error (The rotor is blocked or the differential pressure in the refrigeration system is too high (>5 bar)).
2	Fan over-current cut-out (The fan loads the electronic unit with more than 1A _{peak}).
1	Battery protection cut-out (The voltage is outside the cut-out setting).

Wire Dimensions

Cross section	Size AWG	Max. length* 12V operation		Max. length* 24V operation		
		[mm ²]	[Gauge]	[m]	[ft.]	[m]
2 wires						
8	8	2.5	8	5	16	
1 wire with terminal block						
8	8	1	3	2	7	

*Length between battery an electronic unit

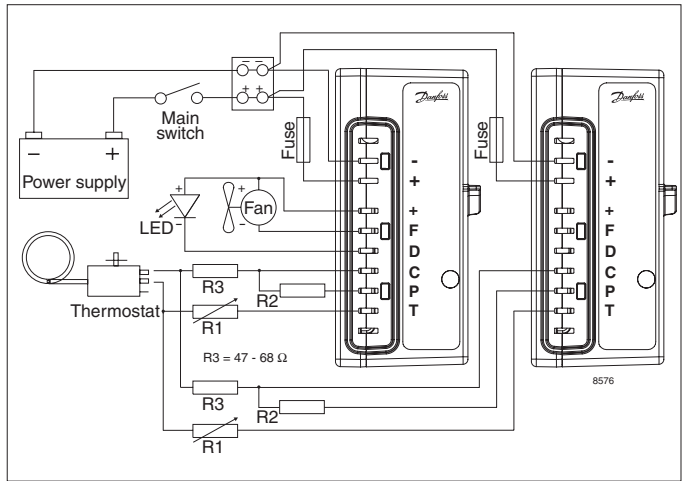
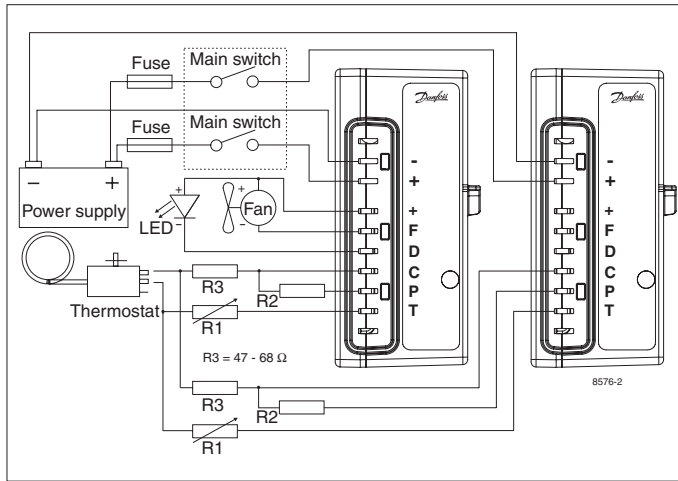

Compressor speed

Electronit unit Code number	Resistor (R1) [Ω]	Motor speed [rpm]	Control circuit current [mA]
101N0290 with AEO	0	AEO	6
	203	2,500	5
	451	3,100	4
	867	3,800	3
	1700	4,400	2

Test conditions	EN 12900/CECOMAF	ASHRAE
Condensing temperature	55°C	54.4°C
Ambient temperature	32°C	32°C
Suction gas temperature	32°C	32°C
Liquid temperature	no subcooling	32°C

Accessories for	BD250/250GH	Code number
Bolt joint for one compressor	Ø: 16 mm	118-1900
Bolt joint in quantities	Ø: 16 mm	118-1901
Snap-on in quantities	Ø: 16 mm	118-1902
Standard automobile fuse DIN 7258	12V: 30A 24V: 15A	Not deliverable from Danfoss
Main switch	rated to min. 30A	

In AEO (Adaptive Energy Optimizing) speed mode the BD compressor will always adapt its speed to the actual cooling demand.

Danfoss can accept no responsibility for possible errors in catalogues, brochures and other printed material. Danfoss reserves the right to alter its products without notice. This also applies to products already on order provided that such alterations can be made without consequential changes being necessary in specifications already agreed. All trademarks in this material are property of the respective companies. Danfoss and the Danfoss logotype are trademarks of Danfoss A/S. All rights reserved.