

Application



Motor module AMER is a P or PI control, for storage tank or heat exchanger control. The module is mounted directly in the motors type AMV 323, AMV 423 and AMV 523.

AMER is used with a Pt 1000 Ω sensor.

A remote control for setting or parallel displacement of required temperature can be connected.

Nine slave motors mitte AMES modules can be connected to the AMER module.

Total range, control voltage range and motor travel direction are selected in using DIP-switches.

AMER has override facility controlled by a time switch or a manual switch. AMER is available in 24 V and 230 V versions.

Principle

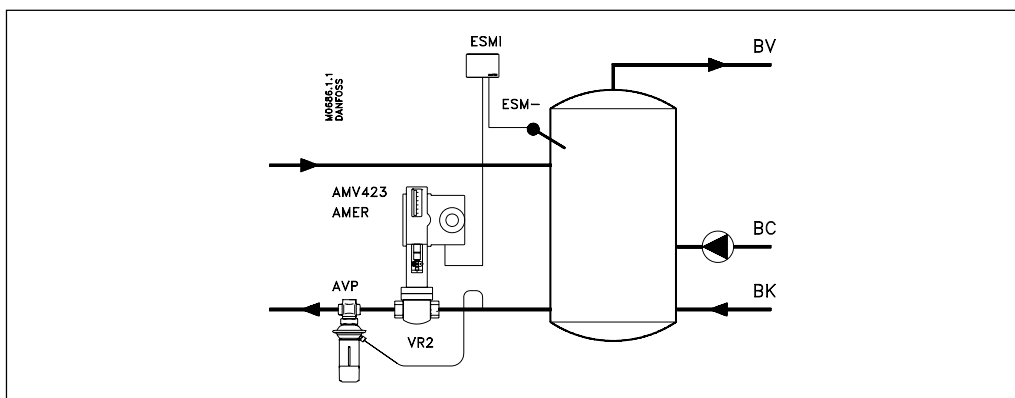
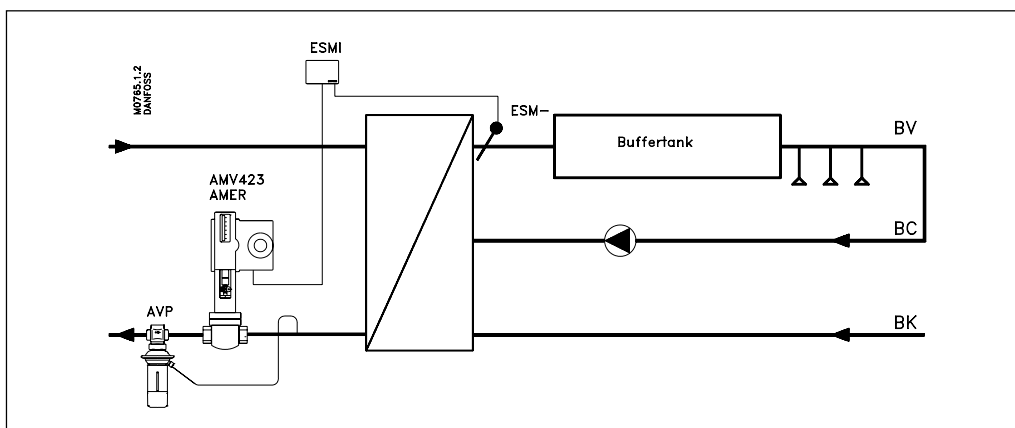

Ordering

Motor modules

Type	Supply voltage	Code no.
AMER	24 V ~	082B3318
AMER	230 V ~	082B3319

Pt 1000 Ω sensor

Type	Description	Code no.
ESMA	Surface sensor	084N1004
ESMU	Immersion sensor, 100 mm pocket	084N1008
ESMU	Immersion sensor, 250 mm pocket	084N1009
ESMR	Room sensor	084N1016
ESMB	Universal sensor	087N0010
ESMI	Remote control	084N1018

Wiring

ESMI (40 - 60°C)

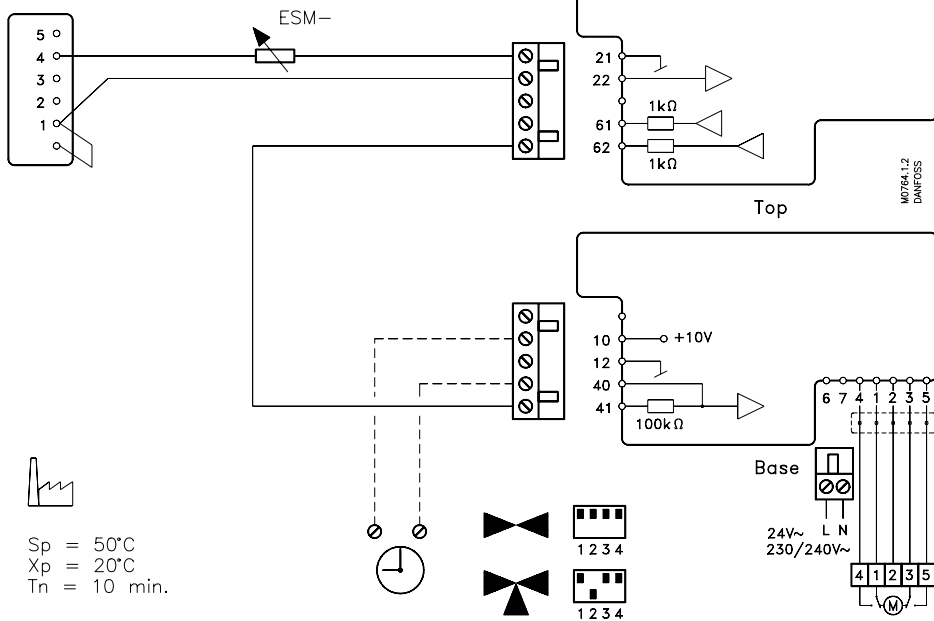

Sp = 50°C
Xp = 20°C
Tn = 10 min.

PI control

ESMI (40 - 60°C)

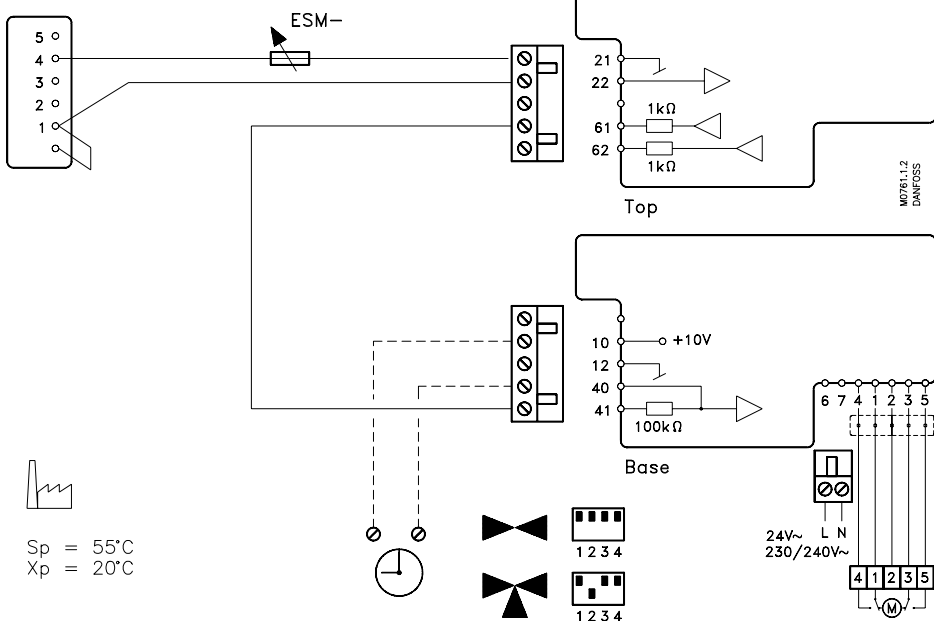

Sp = 55°C
Xp = 20°C

P control

Terminals 6 and 7:
Supply voltage

Terminals 1, 2, 3, 4 and 5:
Supply voltage from AMER to
motor terminal board.

Terminals 21, 22:
Connection for Pt 1000 Ω
sensors.

Terminal 61:
0 - 10 V output signal for
P control.

Terminal 62:
0 - 10 V output signal for
PI control.

Terminal 10:
10 V output.

Terminal 12:
Common (0 V d.c.).

Terminal 40/41:
Input for control voltage from
terminal 61 or 62 (P or PI
control).
Input 40 has higher priority
than input 41.

If override is required, control
signal must be connected to
terminal 41. Terminal 40 can
then be used to connect
motor override unit, e.g. a
frost protection thermostat.
On removing potential from
terminal 40 (using a contact)
override is cancelled.

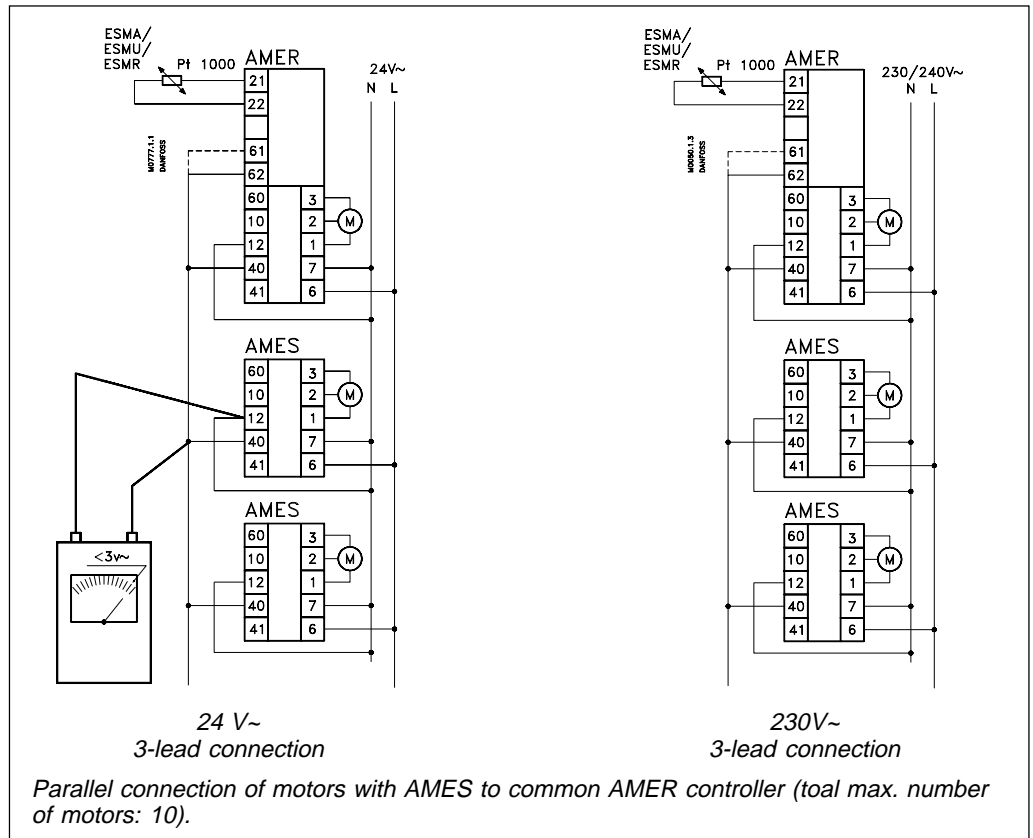

Setting

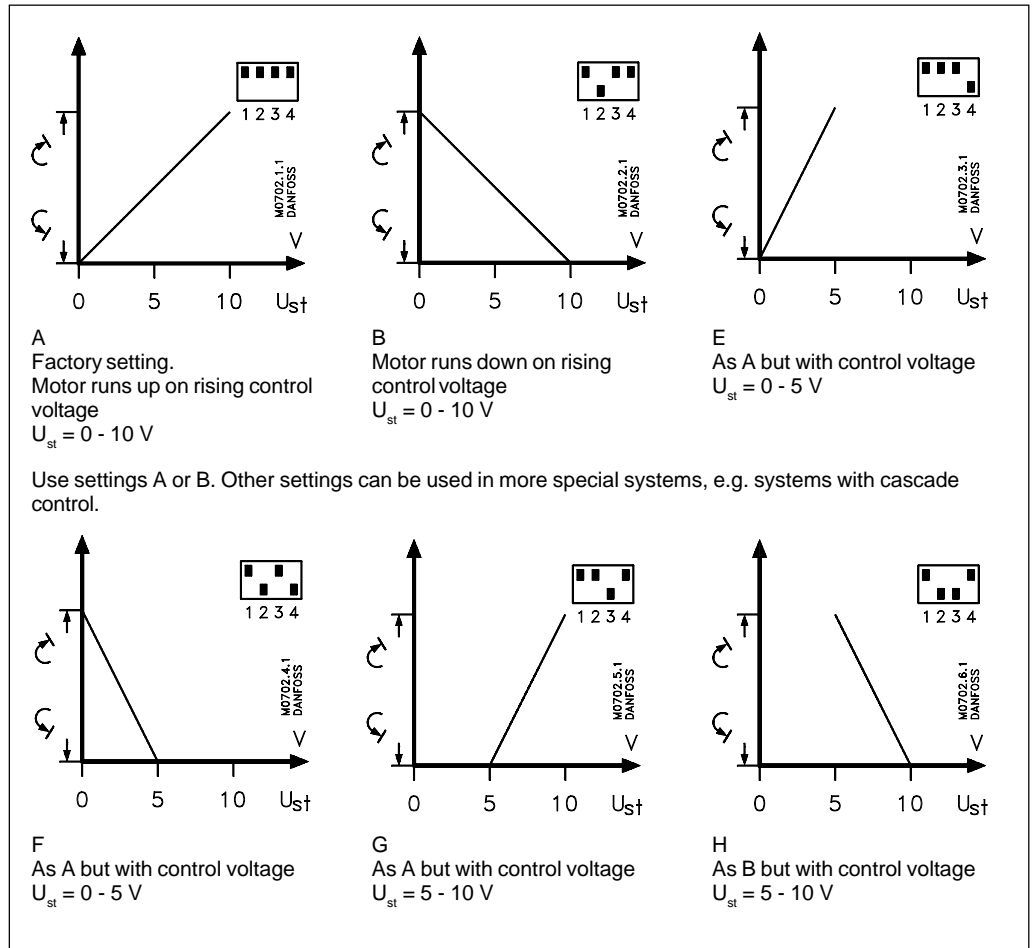

Data

AMER

Mains voltage	24 V~ ±10%, 230/240 V~ (+6% - -10%)
Frequency	50 - 60 Hz
Consumption	3 VA
Control signal input	0 - 10 V, 0 - 5 V, 5 - 10 V
Position indication	0 - 10 V
Output for position control	10 V
Input sensor	Pt 1000 (1000 Ω at 0 °C)
Control principle	P and PI
Set point S_p	15 - 95 °C
Proportional band X_p	2 - 40 °C
Time constant T_n	1 - 20 min.
Mounting	Must be installed in motor on shaft and staybolt
Ambient temperature	min. -15 °C - max. 50 °C
Transport- and storage temp.	min. -40 °C - max. 70 °C
Weight	0.3 kg

Mounting

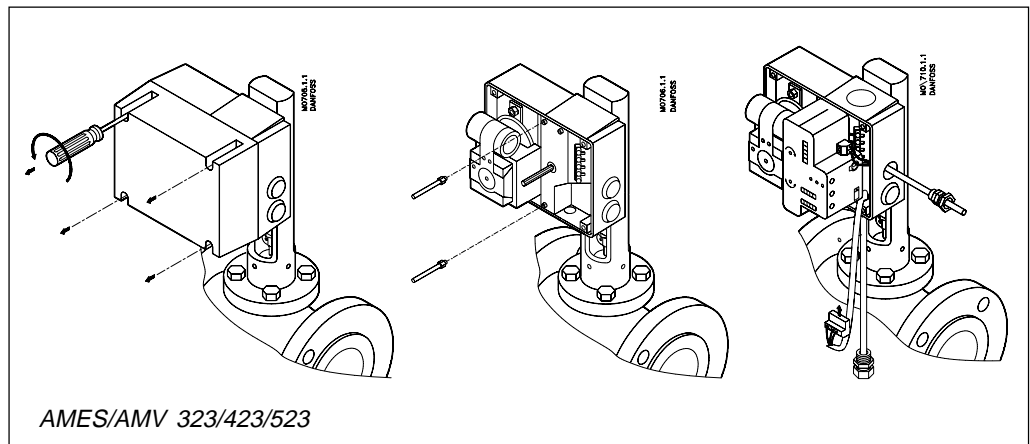

Danfoss can accept no responsibility for possible errors in catalogues, brochures and other printed material. Danfoss reserves the right to alter its products without notice. This also applies to products already on order provided that such alterations can be made without subsequential changes being necessary in specifications already agreed. All trademarks in this material are property of the respective companies. Danfoss and the Danfoss logotype are trademarks of Danfoss A/S. All rights reserved.