

Installation guide

Contactors CI 6 - CI 30

Thermal overload relays TI 16C - TI 25C - TI 30C

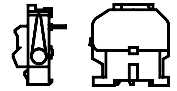

037C0615

037C0615



Before installing the contactor, make sure that the control voltage supply corresponds with the specified voltage. Wrong control voltage across the terminals (A1 and A2) can cause contactor chattering or coil overheating and damage.

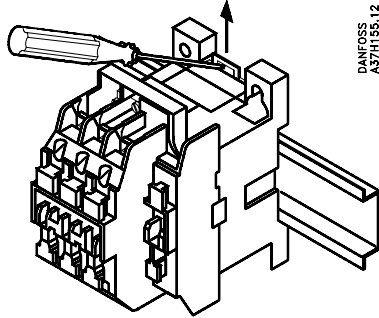

Danfoss
A37H155.12

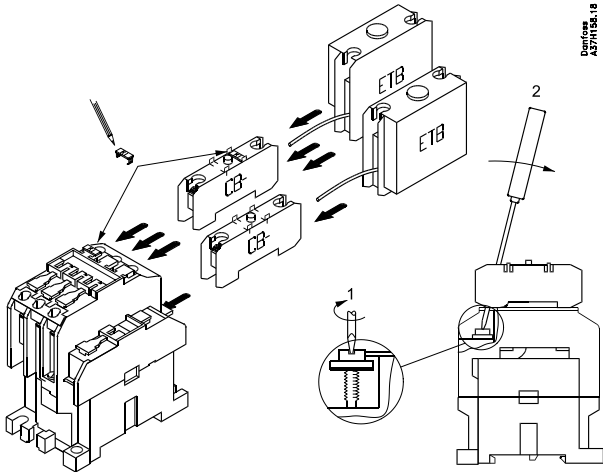

Danfoss
A37H155.16

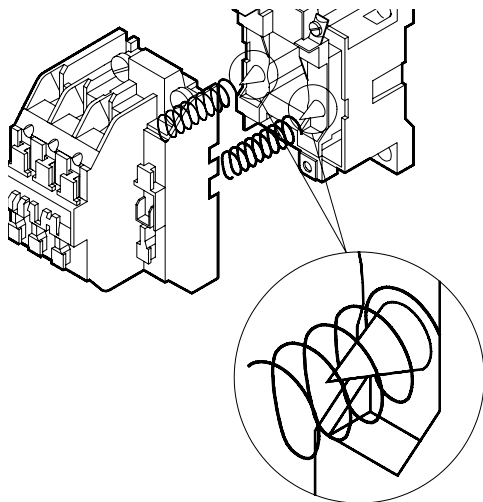

Control voltage must be applied within tolerances given below:

- Standard coil: from -15% to 10%
- Double frequency coil: $\pm 10\%$

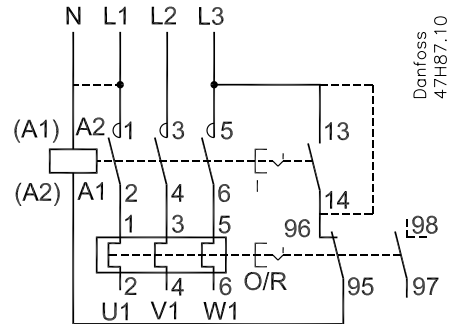

Danfoss
47H87.10

Danfoss
47H01.10

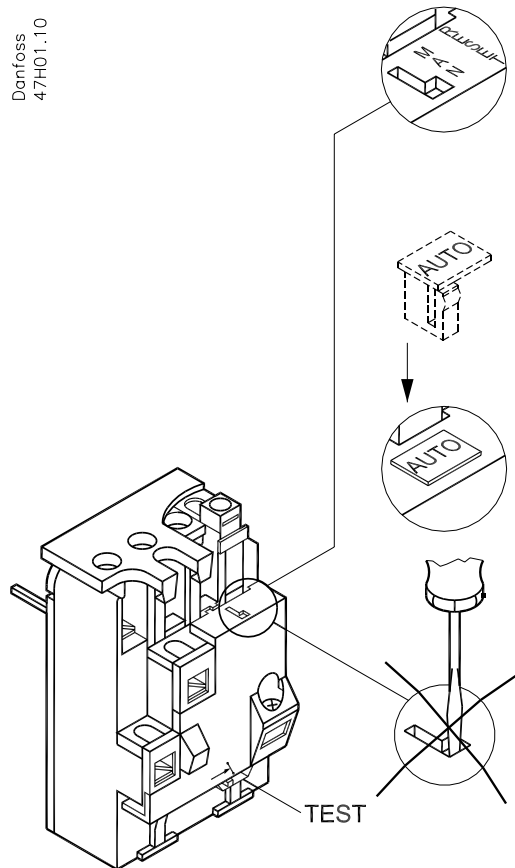

TI 16C / TI 25C / TI 30C



Conditional Short Circuit Rating - Suitable for use on circuits capable of delivering not more than 100 000 rms symmetrical amperes, 600 V maximum when protected by Class J fuses

Contactors CI 32 - CI 50

Thermal overload relay TI 80

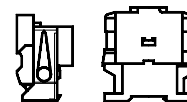

Before installing the contactor, make sure that the control voltage supply corresponds with the specified voltage. Wrong control voltage across the terminals (A1 and A2) can cause contactor chattering or coil overheating and damage.

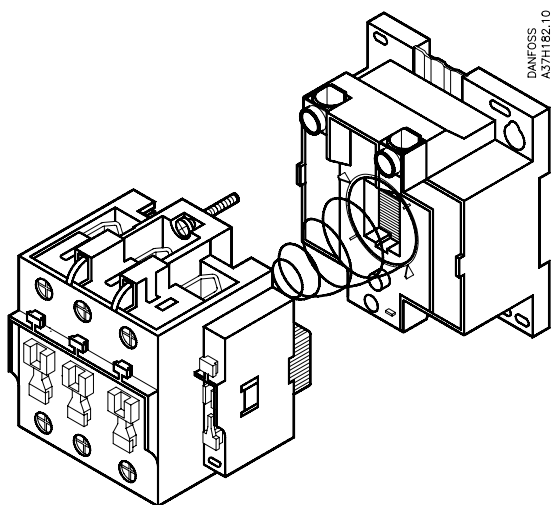
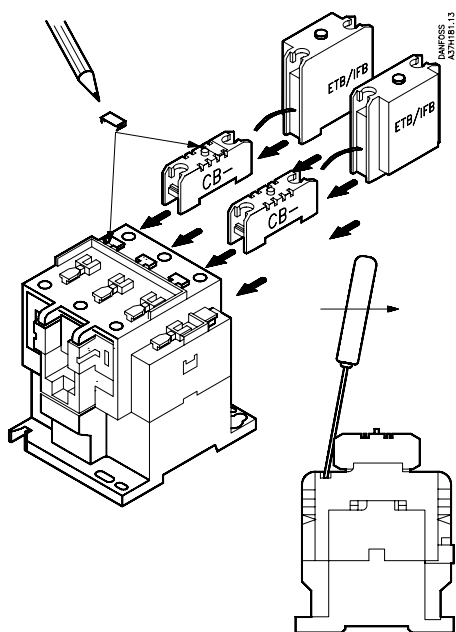
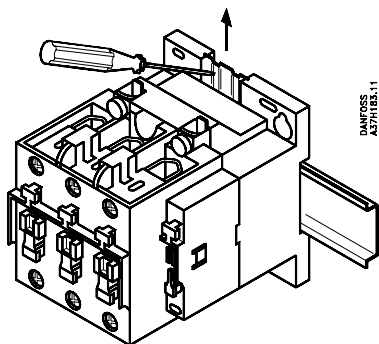

Control voltage must be applied within tolerances given below:

- Standard coil: from -15% to 10%
- Double frequency coil: $\pm 10\%$

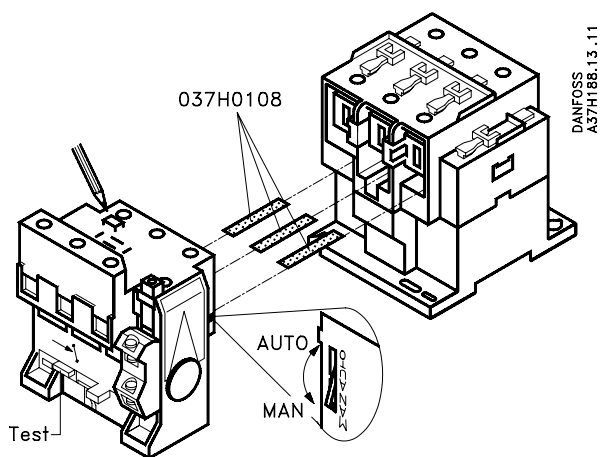
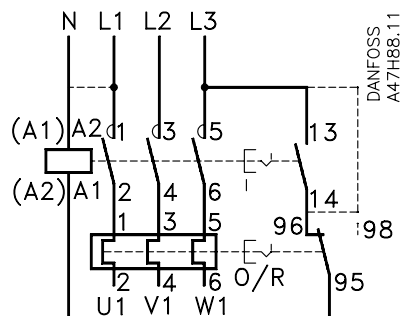

TI 80



Conditional Short Circuit Rating - Suitable for use on circuits capable of delivering not more than 100 000 rms symmetrical amperes, 600 V maximum when protected by Class J fuses