

ENGINEERING  
TOMORROW

*Danfoss*

Technical Information

# e-Wheel 100

Passive Force Feedback Electric Steering Wheel Bas



Date	Changed	Rev
January 2020	Second Edition : Corrected RPM operating speed	0102
September 2019	First Edition	0101

© 2019 Danfoss A/S. All rights reserved

All trademarks in this material are properties of their respective owners.  
PLUS+1, GUIDE aSauerDanfoss are trademarks of Danfoss A/S.

Table of Contents

Literature References .....	4
OEM responsibility .....	5
Introduction .....	6
e-Wheel 100.....	
Features of eWheel.....	
Benefits of eWheel.....	
e-Wheel Safety Functions.....	
Application Example.....	
Different steering wheel sizes.....	
e-Wheel Torque Control Algorithms .....	10....
Information Flow Block Diagram.....	
Graphical Representation of Torque featuring various control algorithms.....	
End-Stop Torque Control.....	
Base Torque Control.....	
RPM Torque Control.....	
Warning Control Torque.....	
Vehicle Speed Torque Control.....	
Technical Data.....	16....
Mechanical characteristics.....	
Electrical characteristics.....	
CAN (Controller Area Network).....	
Connector type and Pin Configuration.....	
Environmental characteristics.....	
Functional Safety.....	
Communication Protocol .....	18....
Messages from eWheel to steering controller [AUX_STW_P and A_STW_R].....	
Messages from Vehicle speed sensor to steering controller and to e-Wheel [VSP_P and VSP_R].....	20
Messages from steering controller to e-Wheel.....	
Installations .....	25....
Dimensions.....	
Instructions.....	
Variant and ordering specifications .....	26....
e-Wheel MMC.....	
Code Numbers.....	
Variants codes for eWheel MMC.....	

Technical Information  
e-Wheel 100

Literature References

Purpose of the document

This document describes the technical specifications and features' information of the e-Wheel, applied with Danfoss electrohydraulic steering valve and steering controller.

References

Literature	Type	Reference number
PVED-CLS	Communication Protocol	L1425546
PVEDCLS	User Manual	L1525062
PVED-CLS	Safety Manual	BC00000331
OSPE Steering valve, SASA Sensor	Technical Information	11068682
EHi Steering Valve	Technical Information	BC00000379

Definitions and Abbreviations

e-Wheel	Electric Steering Wheel Base
SbW	Steer-byWire
AgPL	Agricultural Performance Level
SIL	Safety Integrity Level
CAN	Controller Area Network
PL	Performance Level
PVEDCLS	Proportional Valve Digital ClosedLoop - Safety (steering valvecontroller)
OSPE	Orbital Steering Product Electrohydraulic steering valve
EHi	Electrohydraulic in-line steering valve
Fail Safe	To detect fault, indicate fault to safe state system and revert to a safe condition in the event of a breakdown or malfunction
Fail Operational	To detect fault, indicate fault to safe state system and continue full operation with enough redundancy level
PAE	Product Application Engineering

## Technical Information e-Wheel 100

### OEM responsibility

The OEM of a machine or vehicle in which Danfoss products are installed has the full responsibility for all consequences that might occur. Danfoss has no responsibility for any consequences, direct or indirect, caused by failures or malfunctions.

- The OEM shall perform a hazard and risk analysis for the target system to analyze if the relevant risks are sufficiently reduced by the safety functions. The safety functions are provided by the involved functional safety elements.
- Danfoss has no responsibility for any accidents caused by incorrectly mounted or maintained equipment.
- Danfoss does not assume any responsibility for Danfoss products if incorrectly applied or the system being programmed in a manner that jeopardizes safety.

## Technical Information e-Wheel 100

### Introduction

#### e-Wheel 100

Danfoss steering products are used in vehicles where the driver must control high steering forces, reliably, comfortably and with maximum safety.

With the introduction of electro-hydraulic steering systems and Steer-by-Wire steering systems, applying electric steering wheel advanced steering features like variable lock ratio, soft stop, anti-drift are possible as easy integration in new vehicles as well as retrofit to upgrade the existing vehicles. Primarily, the objective of electric steering wheel is to offer high quality steering feel, providing better operator comfort and reduce operator fatigue. To meet this objective, Danfoss is now offering electric steering input device 'e-Wheel 100'.

Electrohydraulic steering system

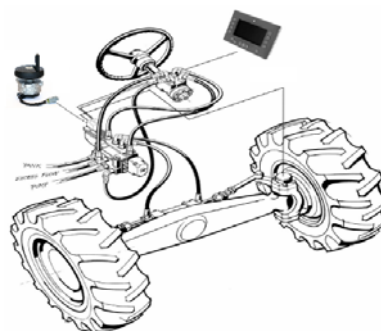

'e-Wheel 100' stands for Electric Steering Wheel Base 100. It represents first of the series of Danfoss electric steering input devices. 'e-Wheel 100' is a haptic steering input device with passive force-feedback torque. 'e-Wheel 100' is referred to as 'e-Wheel' further in this document. The measured input steering angular position and the rate of change of steering angle of the wheel are transmitted to steering valve controller, which determines the preferred steering response.

- x e-Wheel is a 'Plug and Play' solution when interfaced directly to steering valve controller (PVED-CLS for details refer PVED-CLS user Manual) together with electro-hydraulic steering units (OSP/E EHi).
- x The communication protocol between e-Wheel and steering valve controller is based on the Danfoss proprietary safety CAN protocol (refer PVED-CLS communication Protocol).
- x e-Wheel sub-system with PVED-CLS, supports realizing safe steering solutions designed to meet SIL 2 / AgPL d by designing the sub-system to a category 3 architecture (refer mini-steering wheel sub-system in PVED-CLS Safety Manual).

In applications where e-Wheel is used as a primary steering input device or auxiliary steering input device, force feedback is necessary as the steering is expected not only to replicate same functions of conventional mechanically linked steering systems (such as hydro-static enforced feedback) but also to provide advanced steering functions like:

- x Directional control and wheel synchronization
- x Variable steering ratio
- x Smooth steering feel

The absence of hydro-static enforced feedback makes operator disconnected with the vehicle steering feedback which may cause over or under steering. So, e-Wheel haptic passive force-feedback, mimics the feel of conventional steering systems, which makes it a special attribute.

#### Features of e-Wheel

- X 'Plug and Play' solution with PVED-CLS steering controller
- X SIL Claim limit : 2
- X Dual channel redundant CAN bus interface
- X High quality steering feel
  - x Smooth steering torque control
  - x Absence of traditional steering wheel backlash and drift
  - x End-Stop feeling when vehicle wheels steered to extreme locks
  - x RPM torque for better controllability during Quick Steer
  - x Warning or event signal via steering wheel vibration

Technical Information  
e-Wheel 100

Benefits of e-Wheel

- X Reduced operator fatigue due to improved ergonomics
- X Benefits for different steering solutions
  - x Electrohydraulic steering solutions
    - x e-Wheel applied as auxiliary steering input device
    - x In case of failure, reliable fallback to the primary manual steering wheel
  - x Fail-Safe SbW solutions
    - x Eliminates steering column
    - x Cabin design freedom for OEMs
    - x Better accessibility for operator flexibility in seat movements and orientation
- X Low power consumption
- X Compact and robust design
- X Easy to install

e-Wheel Safety Functions

1. Safe Steering Angular Position and Safe Steering Speed  
Two Channels of e-Wheel (each channel provides sub-system elements as the hall effect angle sensors, microprocessor logic blocks, power supply conditioning and protection, CAN transceivers) independently measure angular positions, calculate steering speeds and transmit both steering angular positions and steering speeds onto CAN bus (safety protocol as per PVED-CLC communication protocol)
2. Safe Force Feedback Brake Torque:  
Applying force-feedback torque by e-Wheel is response to the data received via CAN bus (safety protocol as per PVED-CLC communication protocol). Software in the microprocessors will run various torque algorithms in response to the system inputs, defining the required current for force feedback brake torque of e-Wheel. Both microprocessors within e-Wheel will also carry out independent monitoring of sub-systems elements to identify and react to subsystem faults.

Application Example

e-Wheel supports category 3 architecture and can be integrated in a Danfoss CAT 3 Steer Steering System with Danfoss EHi / OSPE and PVED-CLC as steering valve controller (refer to EHi / OSPE Technical Information Document). Below examples shown in figure 1, we consider a Fail-Safe steering solution with Steer-Wire (SbW) system

Components	Description
e-Wheel 100	Primary steering input device
EHi (configuration type 7)	Electrohydraulic steering unit
PVED-CLC	Steering valve Controller
WAS	Dual Analogue Wheel Angle sensor
VSP	CAN Vehicle Speed Sensor (Dual Channel)
MMI	Man-Machine Interface as well as a Gateway for primary vehicle speed message (Dual Channel)
MC012	External Controller (as a redundant controller) for secondary vehicle speed message
Vehicle ECU	OEM controller for braking function during any malfunction or events of failure

Technical Information  
e-Wheel 100

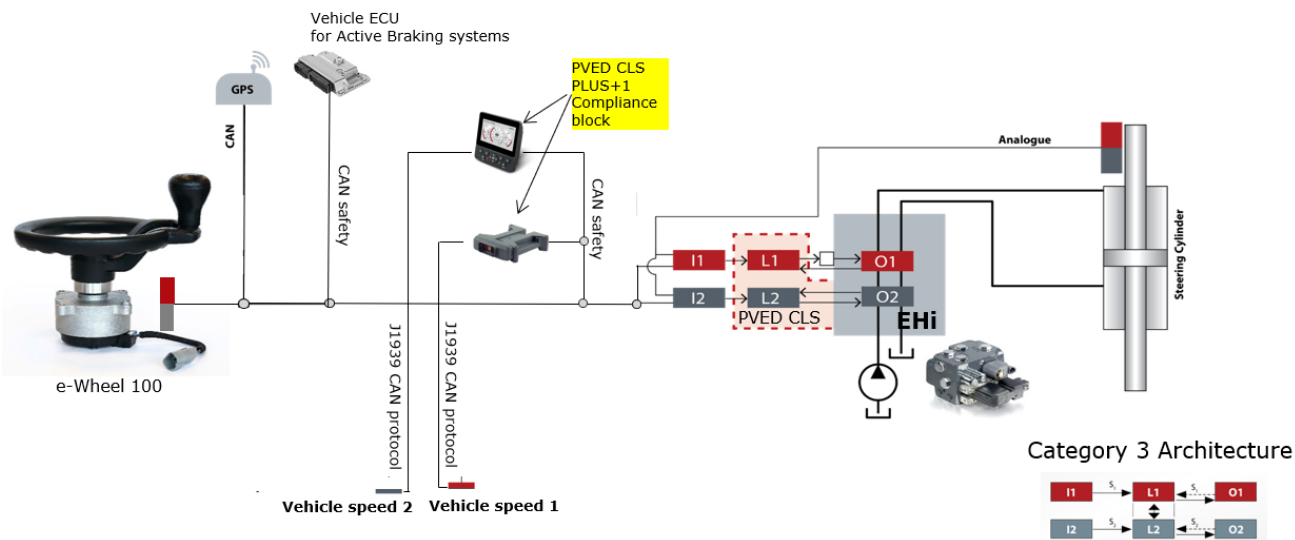

Figure 1 Fail-Safe Steer-by-Wire steering subsystem with e-Wheel

Here, e-Wheels is the primary steering input device in the vehicle with Fail-Safe steering system, which transmits the steering angular positions and the rate of change of steering angle, via CAN bus, to the steering valve controller. The steering valve controller uses the dual redundant analogue wheel angle sensor inputs, dual redundant vehicle speed messages and dual MMI (display) messages as per PVED-CLS communication protocol. In this example, vehicle speed (VSP) message per standard CAN J1939 protocol. So, the VSP messages further needs to be converted from standard CAN protocol to PVEDS communication protocol using PLUS+1 functional block in the two redundant external controllers (Danfoss Display and Danfoss MIC Controller). With above messages along with the e-Wheel inputs, steering valve controller determines the appropriate steering response.

For vehicles with Fail-Safe SbW steering systems only using EHi steering valve, manual activated emergency steering will not be possible. Such steering systems must be set up with complete redundancy and limited only for off road usage. In case of failures, vehicles must be brought to a defined safe state, for instance by stopping the vehicle or switching to a backup steering system. shown in figure 1, during the malfunction or events of failure, based on the operational status message from the steering controller and the vehicle speed CAN safety message from the two plus+1 controllers, the vehicle ECU can signal the vehicle brake systems for reduction of the speed and stopping the vehicle as a safe state response. Vehicle builder necessarily must perform hazard and risk analysis, to have a "safe vehicle brake" safety function which the steering sub-system can demand. In order to integrate with above steering system, suggested category is category 3. The steering controller will not transmit any status message from the braking system and no action is intended to steering system related to the status of the braking system.



Technical Information  
e-Wheel 100

Different steering wheel sizes

Danfoss offers e-Wheel-1 without mounting any top steering wheel, shown as per figure 2.

The shaft of e-Wheel is a 'flat D-shaped' shaft with:

- x with a maximum axial force of 1500 N
- x bending moment of 50 Nm



Figure 2

The steering wheels to be mounted on top, must be machined in a way that they accept the 'flat D-shaped' shaft of e-Wheel as shown in figure 3.

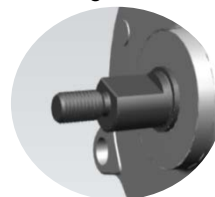





Figure 3

Below are few possibilities of different steering wheel sizes that can fit on shaft of the e-Wheel

Examples* (* Danfoss does not offer the steering wheels, below are just the possibilities with the e-Wheel)	Steering wheel sizes to fit on e-Wheel	Recommended Torque for corresponding steering wheel size	Recommended Part Numbers
	Mini-steering wheel	2 Nm	11224128 / 11198022
	Medium size steering wheel	5 Nm	11224129 / 11243182
	Larger size steering wheel	5 Nm	11224129 / 11243182

Recommendation:

- x Danfoss offers e-Wheel with 5 Nm and 2 Nm as standard variants for maximum operating torque. The choice of these variants majorly depends on the type of application and the type of steering wheel size required in respective application.

Technical Information  
e-Wheel 100

e-Wheel Torque Control Algorithms

The passive force-feedback torque is controlled by applying a proportional current, where the current is function of the below mentioned control algorithms in e-Wheel Force feedback torque will be based on, only one commanded control algorithm offering maximum torque out of all available control algorithms in the configured variant of e-Wheel at any instant applicable during steering. Below is the list of e-Wheel Torque Control Algorithms:

- x End Stop Torque
- x Base Torque
- x RRM Torque
- x Vehicle Speed Dependent Torque
- x Warning Control Torque

Information Flow Block Diagram

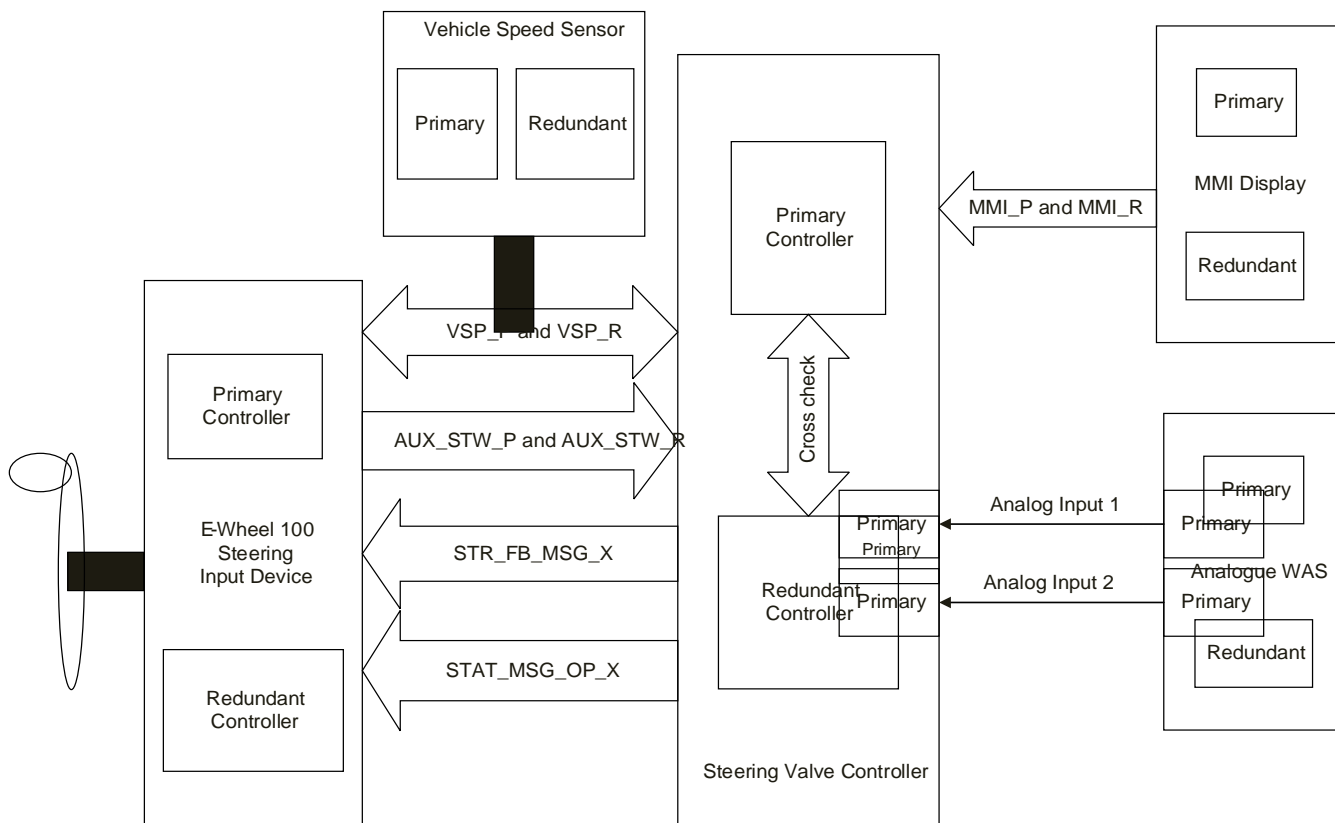

Figure 4 Block diagram for e-Wheel with steering valve controller

The operation between e-Wheel and steering controller in the steering system with relevant messages from each component is simplified in figure 4. In terms of the primary purpose of e-Wheel is giving steering inputs (steering angle and steering speed); whereas the steering controller is defining the steering response based on the data available from all components in steering subsystem. The messages from each component in figure 4, are as per the PVED-CLS communication protocol, specified with the respective annotations.

Recommendation:

- x e-Wheel being a 'Plug and Play solution' with PVED-CLS, it is recommended to use PVED-CLS steering valve controller
- x The Steering Primary and Redundant Controller must perform the cross checks to use e-Wheel as a safe way, refer PVED-CLS Safety Manual.
- x In Off Road Reaction/Non reaction mode, the controller detects an open loop device (e-Wheel 100) when, the steering wheel velocity and the steering wheel angular position is above the threshold set in steering controller, along with the pre-condition that AUX device is set present and is allowed to steer (see flags in MMI message as per PVED-CLS communication protocol).

Graphical Representation of Torque featuring various control algorithms

The control algorithms in e-Wheel, are offered as standard variants with the torque values shown as per figure 5 and figure 6.

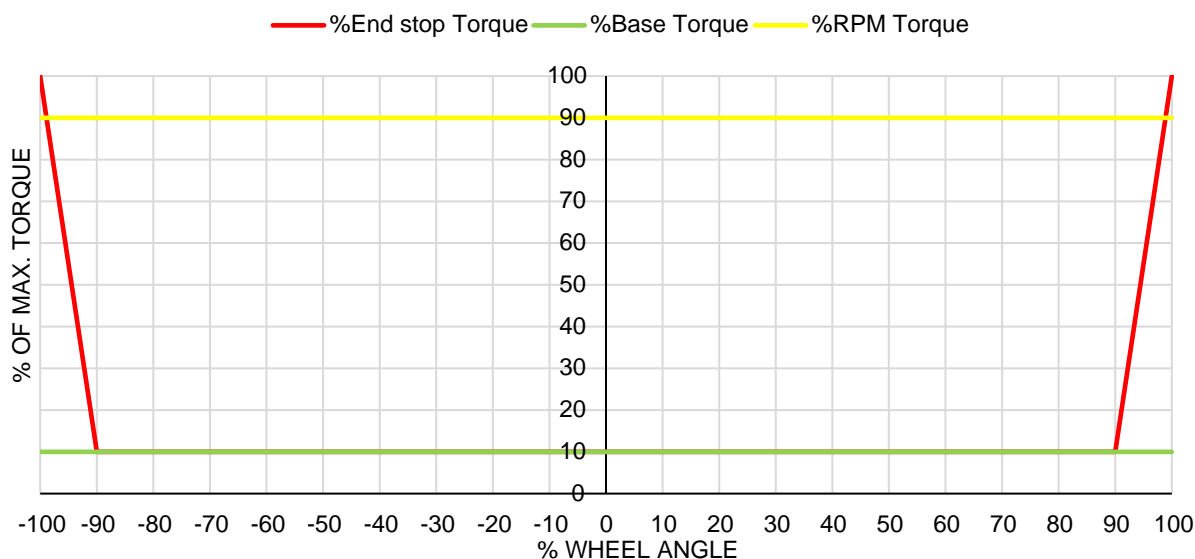

Figure 5 Torque Control Algorithms for 5 Nm

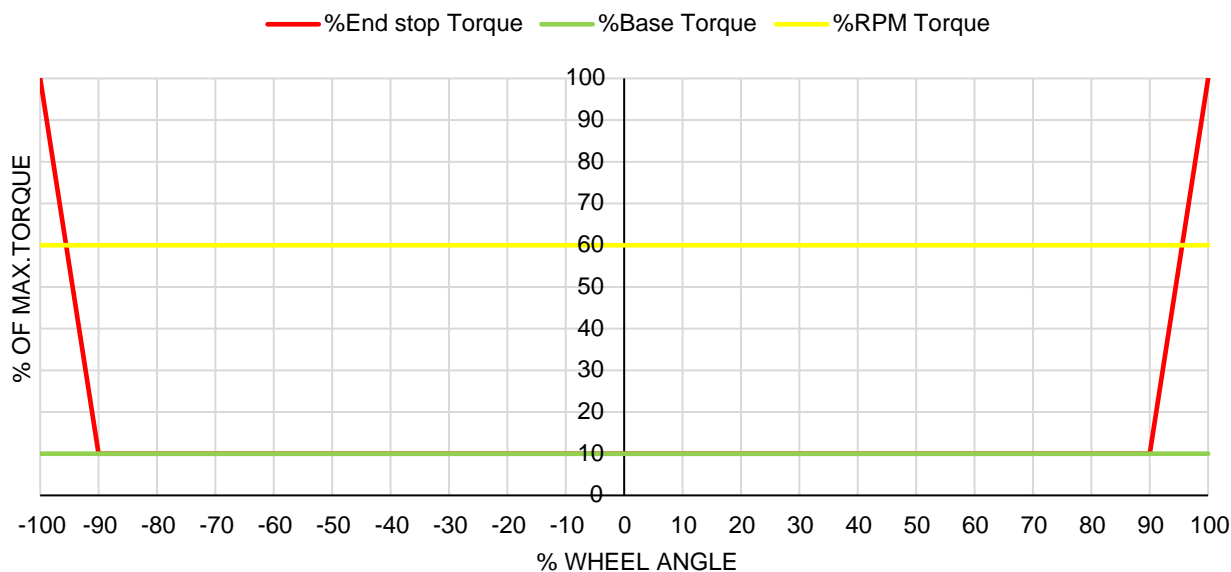

Figure 6 Torque Control Algorithms for 2 Nm

In above figures 5 and 6 respectively,

- x  $\pm 100$  % wheel angle shall correspond to maximum wheel angles on right and left end stop.
- x Figure 5 represents for e-Wheel with 5 Nm as 100 % of the maximum operating torque and figure 6 represents for e-Wheel with 2 Nm as 100 % of the maximum operating torque.
- x RPM torque in both the above graph depicts that it can be experienced irrespective of the wheel angle position,

## Technical Information e-Wheel 100

depending upon the allowable RPM at corresponding steering lock to lock ratio from steering controller. Figure 5 shows, the maximum RPM torque for 5Nm is defined for 90 % of the maximum operating torque; whereas figure 6 shows RPM torque for 2Nm is defined for 60 % of the maximum operating torque.

### End-Stop Torque Control

Wheel angle sensors close the feedback loop with the steering controller, ensuring the vehicle's wheels match steering commands. During the operation, steering controller transmits the estimated wheel angle values as a feedback message over CAN bus to the e-Wheel. Based on this message, e-Wheel detects the wheel angle values and determines the torque force feedback. As shown in figure 5 and figure 6, the End-Stop control algorithm increases linearly from 90 % to 100 % wheel angles and provides maximum operating torque (torque of 5Nm or 2Nm based on the chosen e-Wheel variant) at 100% wheel angle. Thus, operator experiences the End-Stop torque feedback, on vehicle wheels reaching the maximum wheel angle. As soon as the operator steers away from the end stop towards neutral, the torque drops to the base torque control, as explained below.

### Base Torque Control

The background torque for normal steering, excluding end-stop conditions, is the base torque control. This torque is smooth and persistent through-out steering at different wheel angles, as shown in figure 5 and figure 6, as 10 % of the maximum operating torque.

### RPM Torque Control

e-Wheel offers more-precise control at low speeds. In material handling applications for instance, vehicles might require two or three steering wheel turns lock to lock, for maneuvering at low speeds. Whereas in other applications, steering wheel turns lock to lock needs to adjust the range to six or more turns for less sensitivity at high speeds. Regardless of how quickly the operator might turn the steering wheel, e-Wheel limits steering speed to not exceed the maximum allowable steering speed for a given lock to lock configuration. The lock to lock configuration is provided in the feedback message from steering valve controller to e-Wheel. This attribute of restricting higher steering speed than allowable steering speed is therefore called as RPM torque control.

Figure 7 shows the amount of torque requested (as a percentage of maximum allowable torque), as the operator approaches the maximum allowable RPM (scaled to 200 internal resolution) for the respective lock to lock ratio. The torque brake in e-Wheel is applied by the algorithm to limit the actual steering speed so that the maximum steering speed is not exceeded highly. Figure 7 shows the maximum RPM torque is limited to 90% of maximum operating torque of 5 Nm. This is applicable in case of medium to larger steering wheel size application.

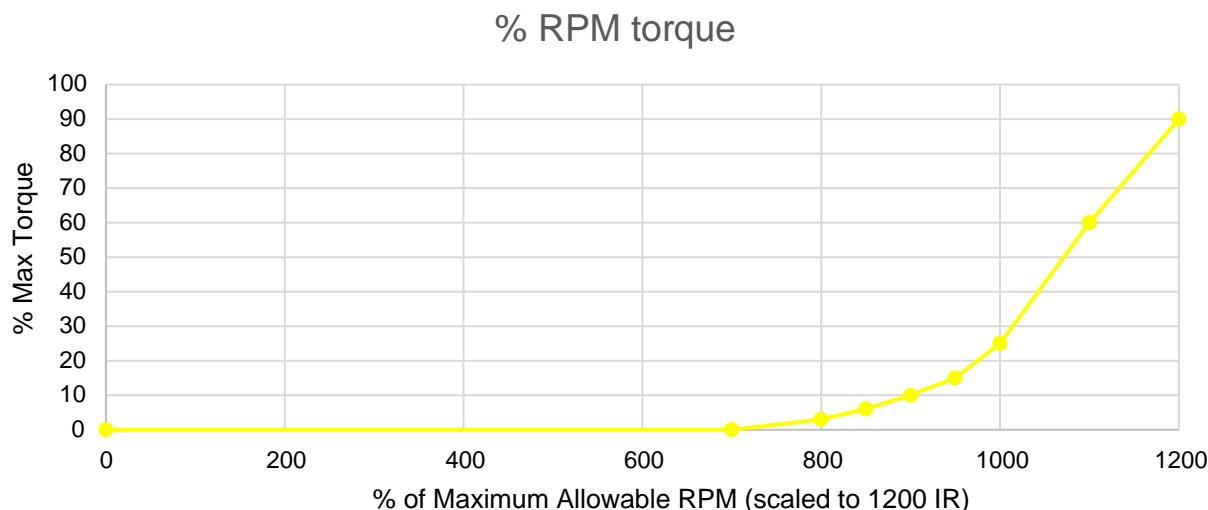

Figure 7 RPM torque for e-Wheel with 5 Nm

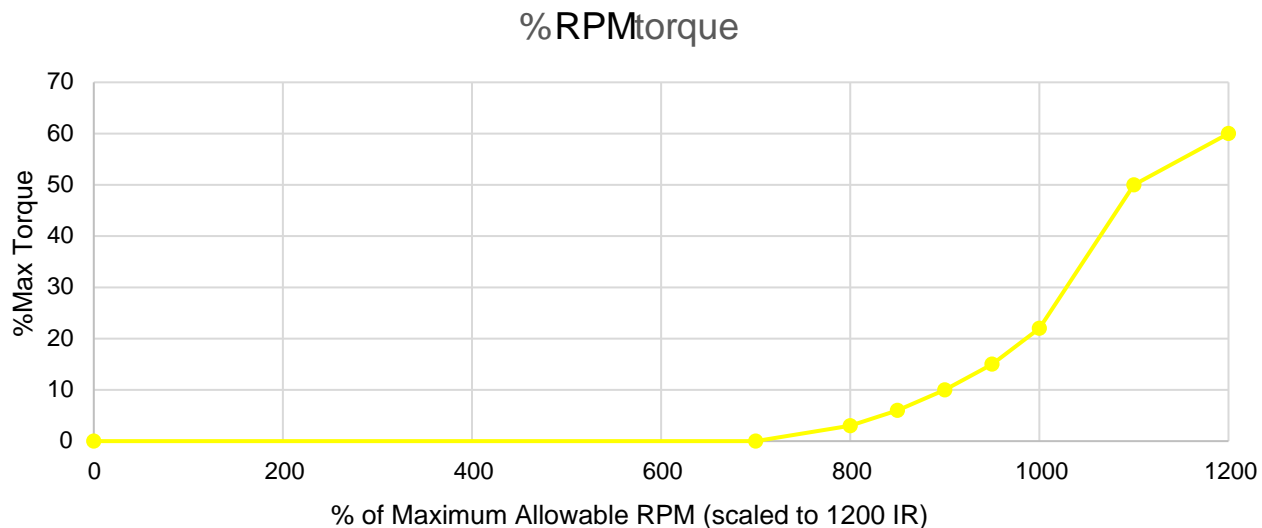

Figure 8 RPM control for Wheel with 2 Nm

Figure 8 shows maximum RPM torque is limited to 60 % of maximum operating torque of 2 Nm. This is applicable in case of mini steering wheel applications.

For different lock to lock shown in below table the Max Allowable steering speed (RPM) default in standard variants is

Lock to Lock	Maximum Allowable steering speed (RPM)
1	25
2	50
3	75
4	100
5	125
6	150
7	175
8	200

Technical Information  
e-Wheel 100

Warning Control Torque

In case of missing messages or errors in CAN messages, steering valve controller goes to safe state and thus the e-Wheel provides relevant error codes to steering valve controller which triggers the steering controller to safe state mode. This makes e-Wheel sendout warning to the operator by vibrational sensation via steering wheel. The vibrational feedback of e-Wheel is called as Warning Control Torque, signals awareness to operator about the loss of steering control. In such events of failure, vehicles must be defined with the necessary safe state conditions.

Steering Controller Outputs			e-Wheel 100 Response
Value (Dec)	Value (Hex)	Current Operation state	Warning Control Torque
0	0x00	On-Road	Active through-out operation state
16	0x10	Off-Road Reaction	Active through-out operation state
17	0x11	Off-Road Nonreaction	Active through-out operation state
32	0x20	STW Program 1	Active through-out operation state
33	0x21	STW Program 2	Active through-out operation state
34	0x22	STW Program 3	Active through-out operation state
35	0x23	STW Program 4	Active through-out operation state
36	0x24	STW Program 5	Active through-out operation state
48	0x30	AUX Program 1	Active only if error occurs
49	0x31	AUX Program 2	Active only if error occurs
50	0x32	AUX Program 3	Active only if error occurs
51	0x33	AUX Program 4	Active only if error occurs
52	0x34	AUX Program 5	Active only if error occurs
64	0x40	GPS Steering	Active only if error occurs
65	0x41	GPS 2 Steering	Active only if error occurs
208	0xD0	Off-Road Safety Check	Active through-out operation state
224	0xE0	Service mode- Direct Output Control	Active through-out operation state
225	0xE1	Service mode- Wheel angle sensor calibration	Active through-out operation state
226	0xE2	Service mode- Spool calibration	Active through-out operation state
227	0xE3	Service mode- Joystick calibration	Active through-out operation state
240	0xF0	Initialization	Active through-out operation state
255	0xFF	Safe State	Active through-out operation state
		Powering up with no controller messages	Active through-out operation state

Technical Information  
e-Wheel 100

Vehicle Speed Torque Control

This torque eliminates vehicle resonances entering e-Wheel by providing gradually increasing torque dependency on vehicle speed.

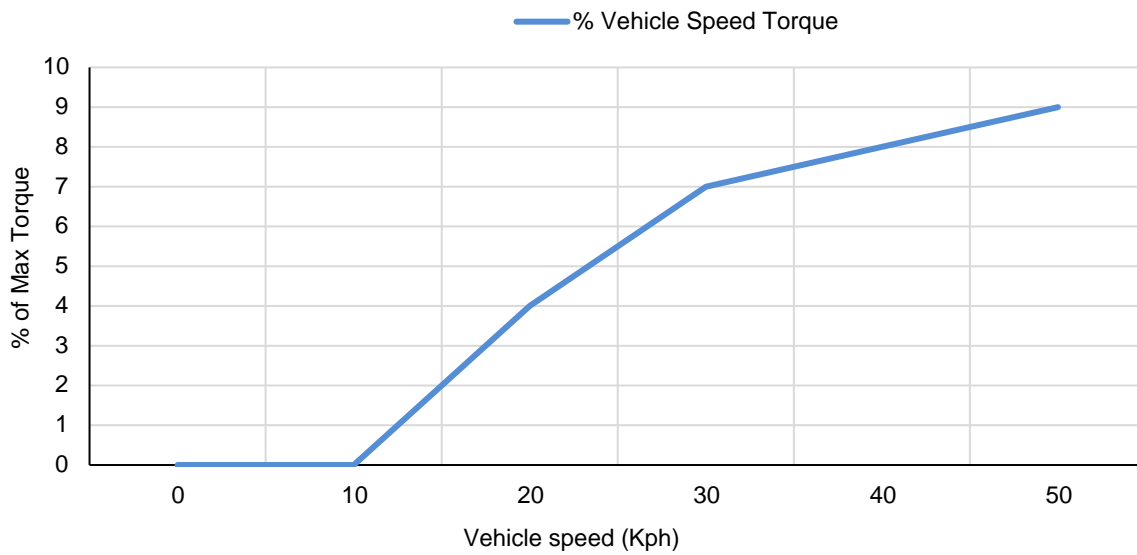

Figure 9 Vehicle Speed Torque

Technical Information  
e-Wheel 100

Technical Data

Mechanical characteristics

Description	Value
Rated Torque	5.5 Nm Nominal (100 % command)
Off-State Torque	<0.5 Nm (0% command)
Operating Speed	300 RPM maximum
MaxAxial Force	1500 N
Max Bending Moment	50 Nm
Shaft Type	D shaped
Rotating Angle	360°, without mechanical stop
Weight	1.5kg

Electrical characteristics

Description	Value
Supply Voltage	12 VDC or 24 VDC- <del>36</del> V), single common power
Coil Resistance	10 nominal
Maximum Power Dissipated	15 Watts
Cable	20 AWG x 4 conductors (Sealed cable with single connector withstandable pull load maximum 100 N)

CAN (Controller Area Network)

Description	Value
Standard	CAN 2.0B
Channels	Two
Baud Rate	250k Baud

Connector type and Pin Configuration

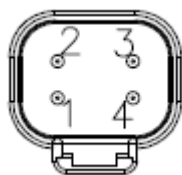

Connector	DEUTSCH DT <del>04P</del> *
-----------	-----------------------------

\*Mating part to be bought externally

PIN	Wire Color	Function
1	White	CANH
2	Blue	CANL
3	Red	V+
4	Black	V-



Technical Information  
e-Wheel 100

Environmental characteristics

Description	Value
Operating Temperature	-40 °C to 85°C
Storage Temperature	-40 °C to 95 °C
Ingress Protection (IP) rating	IP66
Environmental Testing Std.	ISO 16750 §5.1 per IEC 60068

Functional Safety

Description	e-Wheel Sensor Safety Specification	e-Wheel Brake Safety Specification
Performance Level (EN 13849-2:2015)	PLd	PLd
Hardware Fault Tolerance (HFT)	1 <sup>(1)</sup>	1
System	Fail Safe	Fail Safe
Safety Element Classification (IEC 62061)	Type B	Type B
Probability of Dangerous Failures (PFHSD) (IEC 62061 : 2005)	1.597 x 10 <sup>-9</sup>	5.289 x 10 <sup>-9</sup>
Safe Failure Fraction (SFF)	98.72%	99.25%
SIL Claim Limit (IEC 62061:2005)	2	2
Architecture (ISO 13849)	Category 3	Category 3
DC	High <sup>(2)</sup>	High
Proof Test Interval / Mission Time	20 years	20 Years
MTTFd per channel (ISO 13849 Table 1)	150 years	180 years
CCF factor (IEC 62061)	5 %	5 %

Notes:

- (1) The sensor system is redundant. If one channel fails, the other channel continues transmitting data. However, the steering controller can no longer perform diagnostics and a system safe state shall be reached. The system integrator must ensure sufficient diagnostics, please refer Block Diagram
- (2) Reaching a DC= High, depends on a correctly working diagnostic function in the steering controller (Refer to the PVED-CLSSafety Manual.)

Technical Information  
e-Wheel 100  
Communication Protocol

The below table shows how the steering controller shall be parameterized in order to correctly send main and redundant sensor CAN messages. The auxiliary steering device will be used for fail-safe applications. (Refer PVEDCLS Communication protocol for further details)

Messages from e-Wheel to Steering Controller			
Sensor message	Default Message ID	Main Controller Parameter	Safety Controller Parameter
Auxiliary Steering Device (Mini STW) – e-WheelPrimary	0x0CFF144F	P3299 =0x4F P3321 =0x14	
e-Wheel =Auxiliary Steering Device (Mini STW) e-WheelRedundant	0x0CFF154F		P3299 =0x4F P3321 = 0x15
Messages from PVEDCLS Steering Controller to e-Wheel			
Steering Feedback	0xCFF1813	P3297 = 0x13	P3297= 0x5A
Operation Status	0x18FF2013	P3297 =0x13	P3297= 0x5A
Messages from Vehicle Speed Sensor to e-Wheel and to Steering Controller			
Vehicle Speed Primary	0xCFF40FB	P3294 =0xFB P3318 =0x40	
Vehicle Speed Redundant	0xCFF41FB		P3294 = 0xFB P3318 = 0x41
Sensor CAN Messages to Steering Controller			
Wheel Angle Sensor Primary	0x0CFF12FA	P3298 = 0xFA P3320 = 0x12	
Wheel Angle Sensor Redundant	0x0CFF13FA		P3298 = 0xFA P3320 = 0x13
Man Machine Interface– Primary	0x0CEF13FC	P3295 =0xFC P3297 =0x13	
ManMachine Interface – Secondary	0x0CEF5AFC		P3295 = 0xFC P3297 = 0x5A

Technical Information  
e-Wheel 100

Messages from eWheel to steering controller [AUX\_STW\_P and AUX\_STW\_R]

This message transmits angle, current, and fault information from the e-Wheel

Priority: 3

Nominal Transmission: 50 ms

Sent by: eWheel

Send to: PVED-CSI Steering controller

Bytes	Encoding	Value/Range	Description
1..2	U16	0..4095  4096..65535	Steering angle 1 relative to the 0-index point [AUX_STW_pos_P] Steering angle in [360/ 4096 degree] steps, where: 0 corresponds to 0 degrees, 4095 corresponds to 359.912 degrees Note: the steering angle rolls over from 4095 to 0 for clockwise activation and from 0 to 4095 for counter clockwise activation  Information not available
3..4	U16	0..40960  40961..65535	Steering angle velocity [AUX_STW_velocity_P]: Steering angle velocity (offset -20480) in [30 / 20480 RPM] steps, where 0 corresponds to -300 RPM (300 RPM counter clockwise) 20480 corresponds to 0 RPM 40960 corresponds to 300 RPM (300 RPM clockwise)  Information not available
5	-	All 1	Reserved
6	Bits 8..5	0 1 2 3 4 5 6 7 8..13 14 15	Error codes [AUX_STW_error_code_P]: Reserved Sensor chip error Steering angle failure CAN input message failure Power failure CPU failure Memory failure Force feedback failure Reserved Temperature warning No Error
	Bits 4..1	0..15	Sequence number [AUX_STW_Seq_P], incremented by 1 in each AUX primary message Rolls over from 15 to 0
7..8	U16	0..65535	CRC16 for data bytes 1..6 [AUX_STW_CRC_P]: Polynomial: 0 x C86C

Note:

- x The above messages should be dual messages for both Primary and Redundant controllers.

## Technical Information

### e-Wheel 100

Messages from Vehicle speed sensor to steering controller and to e-Wheel [VSP\_P and VSP\_R]

This message contains information from the steering controller to the e-wheel

Nominal Transmission: 10ms

Priority: 3

Sent by: Vehicle Speed

Sensor Send to: e-Wheel

Bytes	Encoding	Value/Range	Description
1	U8	All 1	Reserved
2	Bits 8..7	00 01 10 11	Direction Indication [ VSP_Dir_R]: Forward Reverse Error Condition Information not available
	Bits 6..1	All 1	Reserved
3..4	U16	0..64255 64256..65535	Vehicle speed [VSP_Speed_P]: Measured vehicle speed in [1/256 kmph] Information not available
5	-	All 1	Reserved
6	Bits 8..5	All 1	Reserved
	Bits 4..1	0..15	Sequence number [VSP_Seq_P] incremented by 1 in each VSP primary message Rolls over from 15 to 0
7..8	U16	0..65535	CRC16 for data bytes 1..6 [VSP_CRC_P]: Polynomial: 0x C86C

#### Vehicle Speed

This parameter specifies the vehicle speed, measured in (1/256 kph).

#### Sequence number

This parameter is an internal counter that runs from 0-15 and then loops back. It could be used by the e-Wheel to check for validity of the incoming message.

#### Note:

- x The above messages should be dual messages for both Primary and Redundant controllers.

Technical Information  
e-Wheel 100

Messages from steering controller to e-Wheel

Feedback Message[STR\_FB\_MSG\_X]

This message contains information from the steering controller to the eWheel, including control commands and relevant system level information.

Priority: 3

Nominal Transmission: 50 ms

Sent by: Steering controller

Send to: eWheel

Note:

- x The above messages are dual messages from both Primary and Redundant controller.

Technical Information  
 e-Wheel 100  
 Operation message [STAT\_MSG\_OP\_X]

This message contains information from the steering controller to the eWheel

Priority: 6

Nominal Transmission: 100 ms

Sent by: Steering controller

Send to: eWheel

Bytes	Encoding	Value/Range	Description
1	U8		Current Operation state [OperationState_X]:
		0x00	On-Road
		0x10	Off-Road Reaction
		0x11	Off-Road Nonreaction
		0x20	STW Program 1
		0x21	STW Program 2
		0x22	STW Program 3
		0x23	STW Program 4
		0x24	STW Program 5
		0x30	AUX Program 1
		0x31	AUX Program 2
		0x32	AUX Program 3
		0x33	AUX Program 4
		0x34	AUX Program 5
		0x40	GPS Steering
		0x41	GPS 2 Steering
		0xD0	Off-Road Safety Check
		0xE0	Service mode - Direct Output Control
		0xE1	Service mode - Wheel angle sensor calibration
		0xE2	Service mode - Spool calibration
0xE3	Service mode - Joystick calibration		
0xF0	Initialization		
0xFF	Safe State		
2	Bits 8..7		Lock-out status for steering device changes [Lockout_device_change_X]:
		00	Steering device changes allowed
		01	Steering device changes prohibited
		10	Error condition
		11	Information not available
	Bits 6..5		Lock-out status for STW/AUX program changes [Lockout_program_change_X]:
		00	Program changes allowed
		01	Program changes prohibited
		10	Error condition
		11	Information not available

	Bits 4..3		Lock-out status for EH steering functionality [Lockout_EH_steering_X]:
		00	EHSteering functionality allowed
		01	EH-Steering functionality prohibited by an external switch
		10	Errorcondition
	Bits 2..1	11	Information not available
			AUX Steering device lockout status [Lockout_AUX_X]:
		00	AUX device steering allowed
		01	AUX device steering prohibited
3	Bits 8..7	10	Error condition
		11	Information not available
			GPS receiver selection and lockout status [Lockout_GPS_X]:
		00	No GPS receiver selected (GPS steering prohibited)
	01	GPS Steering selected	
	10	GPS 2 Steering selected	
	Bits 6..1	11	Reserved
4	U8	All 1	Reserved
			Service mode state [Service_mode_state_X]:
		0x00	Direct output control reset
		0x01	Direct output control active
		0x02..0x0F	Reserved
		0x10	WAS calibration Reset
		0x11	WAS calibration in progress
		0x12..0x1C	Reserved
		0x1D	WAS calibration counter update
		0x1E	WAS calibration failure
		0x1F	WAS calibration complete
		0x20	Spool calibration reset
		0x21	Spool calibration inactive
		0x22	Spool calibration getting armed
		0x23	Spool calibration armed
		0x24	Spool calibration in progress
		0x25	Spool parameters plausibility check
		0x26	Spool parameters ready to update
		0x27	Spool parameters update
		0x28..0x2C	Reserved
		0x2D	Spool calibration counter update
		0x2E	Spool calibration failure
		0x2F	Spool calibration complete
		0x30	Joystick calibration Reset
		0x31	Joystick calibration in progress

Technical Information  
e-Wheel 100

		0x32..0x3C	Reserved
		0x3D	Joystick calibration counter update
		0x3E	Joystick calibration failure
		0x3F	Joystick calibration complete
		0x40..0xFC	Reserved
		0xFD	No analog joystick configured
		0xFE	No wheel angle sensor configured
		0xFF	Information not available (Operation state other than service mode)
5	-	All 1	Reserved
6	Bits 8..5	All 1	Reserved
	Bits 4..1	0..15	Sequence number [OperationState_Seq_X]: Incremented by 1 in each Operation status message. Rolls over from 15 to 0
7..8	U16	0..65535	CRC16 for data bytes 1..6 [OperationState_CRC_X]: Polynomial: 0x86C

Note

- x The above messages are also messages from both Primary and Redundant controllers
- x In Off Road Reaction/Non reaction mode, the controller detects AUX open loop device (e-Wheel 100) when, the steering wheel velocity and the steering wheel angular position is above the threshold set in steering controller, along with the pre-condition that AUX device is set present and is allowed to steer (see flags in MMI message as per PVED CLS communication protocol).



Technical Information  
e-Wheel 100  
Installations  
Dimensions

#### Instructions

- To be installed such that shaft is between vertical axis and  $-10^{\circ}$  from horizontal axis
- Avoid misalignment that causes excessive load

Technical Information  
e-Wheel 100

Variant and ordering specifications

e-Wheel MMC

Determine Master Model Code (MMC). Fill in with code for eWheel and variant codes for eWheel to specify eWheel100. MMC values for eWheel

e-Wheel 100										
-------------	--	--	--	--	--	--	--	--	--	--

Example only

e-Wheel 100 <sup>1</sup>	CAN <sup>2</sup>	5 <sup>3</sup>	ES <sup>4</sup>	BS <sup>5</sup>	RPM <sup>6</sup>	Reserved <sup>7</sup>	VSP <sup>8</sup>	D <sup>9</sup>	Package <sup>10</sup>
--------------------------	------------------	----------------	-----------------	-----------------	------------------	-----------------------	------------------	----------------	-----------------------

<sup>1</sup> e-Wheel 100 base

<sup>2</sup> Communication channel

<sup>3</sup> Maximum Operating Torque (Nm)

<sup>4</sup> End Stop Torque (Nm)

<sup>5</sup> Base Torque (Nm)

<sup>6</sup> RPM Torque (Nm)

<sup>7</sup> Reserved

<sup>8</sup> Vehicle Speed Torque (Nm)

<sup>9</sup> Connector Type

<sup>10</sup> Package

Code Numbers

Configuration Numbers, in the following table, are referring to matrix description for eWheel standard configurations. Code numbers for catalog versions with specifications

Code No.	Configuration No.	MMC Specifications according to above description format								
11224128	Type 1	CAN	2	ES	BS	N	-	VSP	D	S
11224129	Type 2	CAN	5	ES	BS	RPM	-	VSP	D	S
11198022	Type 3	CAN	2	ES	BS	N	-	VSP	D	M
11243182	Type 4	CAN	5	ES	BS	RPM	-	VSP	D	M

Technical Information  
e-Wheel 100

Variants codes for e-Wheel MMC

1) e-Wheel100base

e-Wheel	Electric Steering Wheel Base
Code	e-Wheel 100

2) CommunicationChannel

Type	Digital
Code	CAN

3) Maximum Operating Torque (Nm)

Maximum Operating Torque	5 Nm	2 Nm
Code	5	2

4) End StopTorque(Nm)

EndStop Torque	Included	Not Included
Code	ES	N

5) BaseTorque(Nm)

Base Torque	Included	Not Included
Code	BS	N

6) RPM(Nm)

RPM Torque	Included	Not Included
Code	RPM	N

7) Reserved

8) VehicleSpeed Torque(Nm)

VSP Torque	Included	Not Included
Code	VSP	N

Technical Information  
e-Wheel 100

9) ConnectorType

Type, Connector	Deutsch DT, one 4 pin
Code	D

10) Package

Package	Single	Multiple
Code	S	M

Technical Information  
e-Wheel 100

Products we offer:

- f DCV directional control valves
- f Electric converters
- f Electric machines
- f Electric motors
- f Gear motors
- f Gear pumps
- f Hydrostatic motors
- f Hydrostatic pumps
- f Orbital motors
- f PLUS+1 controllers
- f PLUS+1 displays
- f PLUS+1 joysticks and pedals
- f PLUS+1 operator interfaces
- f PLUS+1 sensors
- f PLUS+1 software
- f PLUS+1 software services, support and training
- f Position controls and sensors
- f PVG proportional valves
- f Steering components and systems
- f Telematics

Danfoss Power Solutions is a global manufacturer and supplier of high-quality hydraulic and electric components. We specialize in providing state-of-the-art technology and solutions that excel in the harsh operating conditions of the mobile off-highway market as well as the marine sector. Building on our extensive applications expertise, we work closely with you to ensure exceptional performance for a broad range of applications. We help you and other customers around the world speed up system development, reduce costs and bring vehicles and vessels to market faster.

Danfoss Power Solutions ... your strongest partner in mobile hydraulics and mobile electrification.

Go to [www.danfoss.com](http://www.danfoss.com) for further product information.

We offer you expert worldwide support for ensuring the best possible solutions for outstanding performance. And with an extensive network of Global Service Partners, we also provide you with comprehensive global service for all of our components.

Hydro-Gear

[www.hydro-gear.com](http://www.hydro-gear.com)

Daikin-Sauer-Danfoss

[www.daikin-sauer-danfoss.co](http://www.daikin-sauer-danfoss.co)

Local address:

Danfoss  
Power Solutions (US) Company  
2800 East 13th Street  
Ames, IA 50010, USA  
Phone: +1 515 239 6000

Danfoss  
Power Solutions GmbH & Co. OHG  
Krokamp 35  
D-24539 Neumünster, Germany  
Phone: +49 4321 871 0

Danfoss  
Power Solutions ApS  
Nordborgvej 81  
DK-6430 Nordborg, Denmark  
Phone: +45 7488 2222

Danfoss  
Power Solutions Trading  
(Shanghai) Co., Ltd.  
Building #22, No. 1000 Jin Hai  
Jin Qiao, Pudong New District  
Shanghai, China 201206  
Phone: +86 21 2080 6201

Danfoss can accept no responsibility for possible errors in catalogues, brochures and other printed material. Danfoss reserves the right to alter its products without notice. This also applies to products already on order provided that such alterations can be made without subsequent changes being necessary in specifications already agreed. All trademarks in this material are property of the respective companies. Danfoss and the Danfoss logotype are trademarks of Danfoss A/S. All rights reserved.