

Data sheet

Rotary position sensor without shaft

DST X520



The Danfoss DST X520 rotary position sensors without shaft are designed for use in mobile hydraulic applications.

Danfoss DST X520 series uses contactless Hall technology with measurement ranges up to 360°. The Sensors designed for off-highway applications and resistant to shock and vibrations and with high electromagnetic compatibility. They are E1 approved for on-highway applications. They come with either analogue, CANopen or SAE J1939 output.

Single and redundant sensor types are available, making the complete portfolio suitable for safety-critical applications.

Features

- Contactless Hall technology for almost infinite sensor life time
- Single or Redundant ranges up to 360° ($\pm 180^\circ$)
- Output: Analogue, CANopen or SAE J1939
- Linearity: $< \pm 0.5\%$ FS
- Resolution:
 - 12 bit (analog)
 - 14 bit (CANopen/SAE J1939)
- IP protection level IP67 - IP69K with female mating connector
- High quality 10 mm SmCo Magnet

Approvals and Conformity

- CE
- RoHS
- E1 approval

Technical data
Performance

Measuring range	CAN	±180° (360 °C)
	Analogue	Programmable ± 15 °C
Linearity		≤ ± 0,5% FS
Resolution and speed of rotation	12 bit (analog output)	120 rpm max.
	14 bit (CANopen/SAE J1939 output)	
Durability		No wear through the use of permanent external magnet

Electrical specifications

Electrical connections	AMP Superseal 6p 282108, Cable or cable + M12
Output signal	CANopen / SAE J1939, Ratiometric 10-90% of Vs, 0,5-4,5 Vdc, 0-10 Vdc or 4-20 mA
Supply voltage	CANopen/J1939, 0,5-4,5 Vdc, 4-20 mA: 9-36 Vdc 0-10 Vdc, 11-36 Vdc Ratiometric: 10-90% of Vs: 5 Vdc
Current consumption	Analogue: < 10 mA/ pr. channel (no load) CANopen/J1939: < 15 mA (no load)
MTTFd [Years]	CANopen/J1939: 336 Analogue: 406 (Single Channel)

Environmental conditions

Operating temperature range		-40 – 85 °C
Thermal drift temperature		< 50 ppm/°C
EMC	Emission	EN 55011 and CISPR 25
	Immunity	EN 61236-3-2 and ISO 11452-2
	Transient on supply lines	ISO 7637-2
	Bulk current injection	ISO 11452-4
Vibration stability	Sinusoidal	20 g, 10 Hz – 2,000 kHz IEC 60068-2-6
Shock resistance	Impulsive on 3 axes	50 g, 11 ms IEC 60068-2-27
IP protection		AMP Superseal: IP67 - IP69K with female mating connect Cable: IP69K Cable + M12: IP67

Mechanical characteristics

Materials	Enclosure	PBT (Polybutylene terephthalate)
Net weight		0.036 kg

Sensor output graph

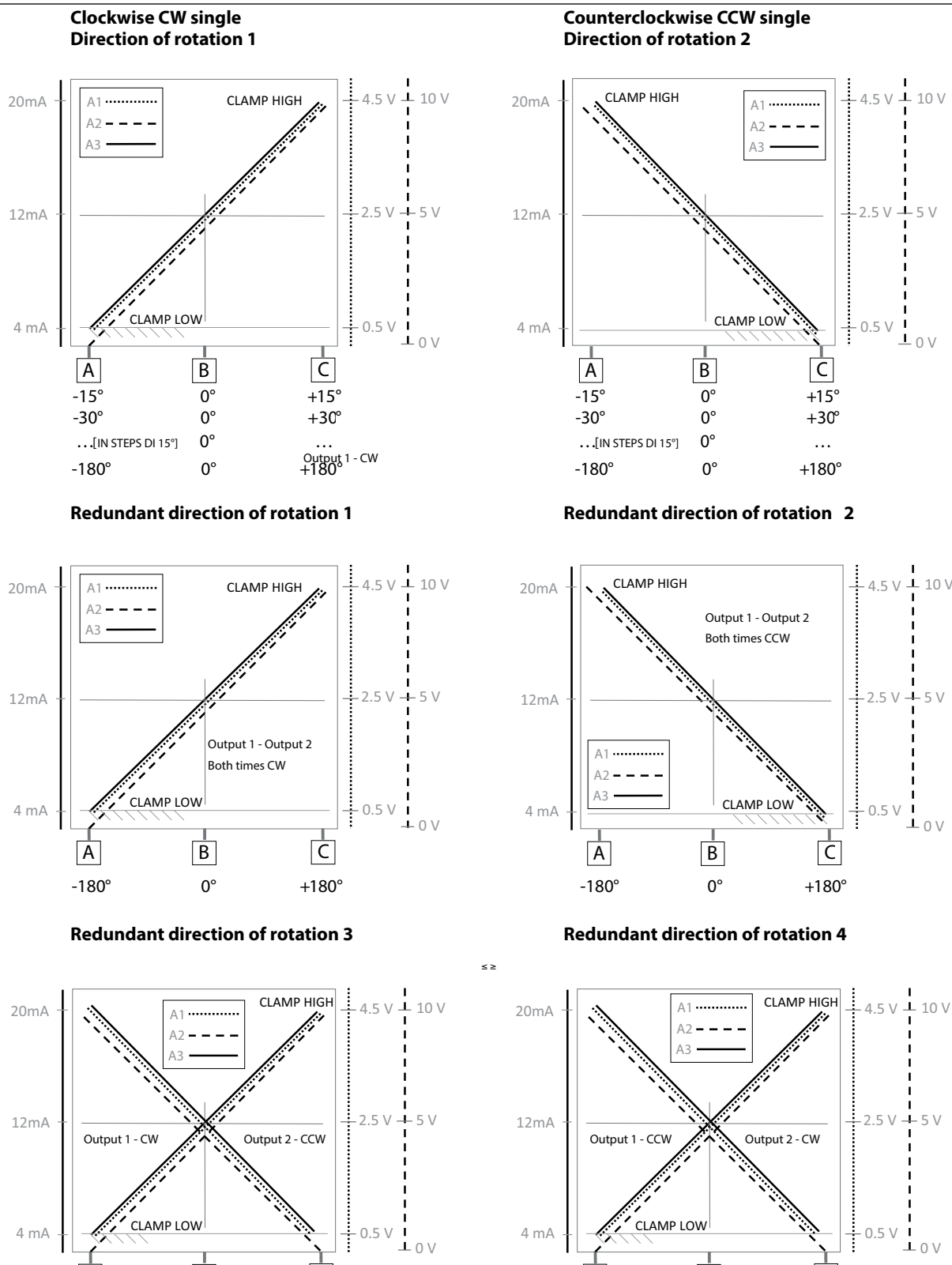

Load conditions

- +0.5V DC – +4.5 VDC output with power +9 – +36V DC and +0 – 10V DC output with power +11– 36V DC: it is recommended a load resistance > 100 K Ω
- +0.5V DC – 4.5 V DC output with power +5 V DC: it is recommended a load resistance > 10 K Ω
- +4 – 20 mA output with power +9-15 V DC: maximum load resistance is 200 Ω
- +4 – 20 mA output with power + 15 – 36V DC: maximum load resistance is 500 Ω

Data sheet | Rotary position sensor without shaft DST X 520
Ordering

Type	Output signal	Configurations	Code no.
DST X 520 incl. PKIT magnet	5V Ratiometric	±180° Clockwise CW	098G1500
	5V Ratiometric	±180° Counterclockwise CCW/CH2 clockwise CW	098G1501
	36 V CANopen	±180° Clockwise CW	098G1502
	36 V SAE J1939	±180° Clockwise CW	098G1503

Others on request

**Ordering code -
on request**

Electrical connections		Cable																											
AMP Superseal 6P connector	A	Single cable without connector (always "0" in case of DST X520 A version)	0																										
Cable (specify cable length)	F	Cable + M12, 5-pin male overprinted connector	1																										
Circuit type		Reserved																											
Single Analog and half redundant CANopen/J1939	S		00																										
Redundant Analog	R	Linearity curve																											
Angle/Channel 1 (output for single channel)		No linearity curve attached																											
(Analog output A1-A2-A3 programmable in steps of ±15°) (CAN/J 1939 = 180)	xxx	Linearity curve to be attached																											
Angle/Channel 2 (redundant/half redundant)		Standard																											
Analog output = same as Channel 1 and (CAN/J 1939 = 000)	xxx		033																										
Supply voltage		Accessories																											
+5Vdc (only for A1 output)	L	No accessories	X																										
+9...+36Vdc (see output signal for right supply voltage)	H	Shaft kit + magnet D 15 M10 hexagonal (PKIT 384) (Standard)	A																										
Output type		Shaft kit to insert + magnet D 15 (PKIT 389)	B																										
+0.5...+4.5V DC output (available with supply L = ratiometric output and with supply H = 0.5...4.5V output)	A1	Kit magnet Ø15 (PKIT 418)	C																										
0...+10Vdc output (powered at +11...36V DC)	A2	Cable length																											
4...20mA output (powered at +9...36V DC)	A3	100 mm	01																										
CANopen output (powered at +9...36V DC) (available in single version with +/-180° measurement range)	C1	200 mm	02																										
SAE J1939 (powered at +9...36V DC) (available in single version with +/-180° measurement range)	C2	500 mm	05																										
Rotation direction		1 m	10																										
Clockwise CW (single) Both clockwise CW (redundant or CAN/J1939)	1	2 m	20																										
Counterclockwise CCW (single) Both counterclockwise CCW (redundant or CAN/J1939)	2	Other length on request																										
CHANNEL 1 clockwise CW and CHANNEL 2 counterclockwise CCW (redundant version or CAN/J1939)	3	Example of ordering: DST X520-AS180000HC14000 0033A00																											
CHANNEL 1 counterclockwise CCW and CHANNEL 2 clockwise CW (redundant version or CAN/J1939)	4	<table border="1"> <tbody> <tr> <td>A</td> <td>AMP Superseal 6p</td> </tr> <tr> <td>S</td> <td>Half redundant CAN/J 1939</td> </tr> <tr> <td>180</td> <td>±180°</td> </tr> <tr> <td>000</td> <td>000</td> </tr> <tr> <td>H</td> <td>+9 - +36 Vdc</td> </tr> <tr> <td>C1</td> <td>CANopen</td> </tr> <tr> <td>4</td> <td>Channel 1: Counterclockwise CCW Channel 2: Clockwise CW</td> </tr> <tr> <td>0</td> <td>No cable</td> </tr> <tr> <td>00</td> <td>Reserved</td> </tr> <tr> <td>0</td> <td>No linearity curve</td> </tr> <tr> <td>033</td> <td>Standard</td> </tr> <tr> <td>A</td> <td>Magnet PKIT384</td> </tr> <tr> <td>00</td> <td>Not defined (only cable version)</td> </tr> </tbody> </table>		A	AMP Superseal 6p	S	Half redundant CAN/J 1939	180	±180°	000	000	H	+9 - +36 Vdc	C1	CANopen	4	Channel 1: Counterclockwise CCW Channel 2: Clockwise CW	0	No cable	00	Reserved	0	No linearity curve	033	Standard	A	Magnet PKIT384	00	Not defined (only cable version)
A	AMP Superseal 6p																												
S	Half redundant CAN/J 1939																												
180	±180°																												
000	000																												
H	+9 - +36 Vdc																												
C1	CANopen																												
4	Channel 1: Counterclockwise CCW Channel 2: Clockwise CW																												
0	No cable																												
00	Reserved																												
0	No linearity curve																												
033	Standard																												
A	Magnet PKIT384																												
00	Not defined (only cable version)																												

Dimensions

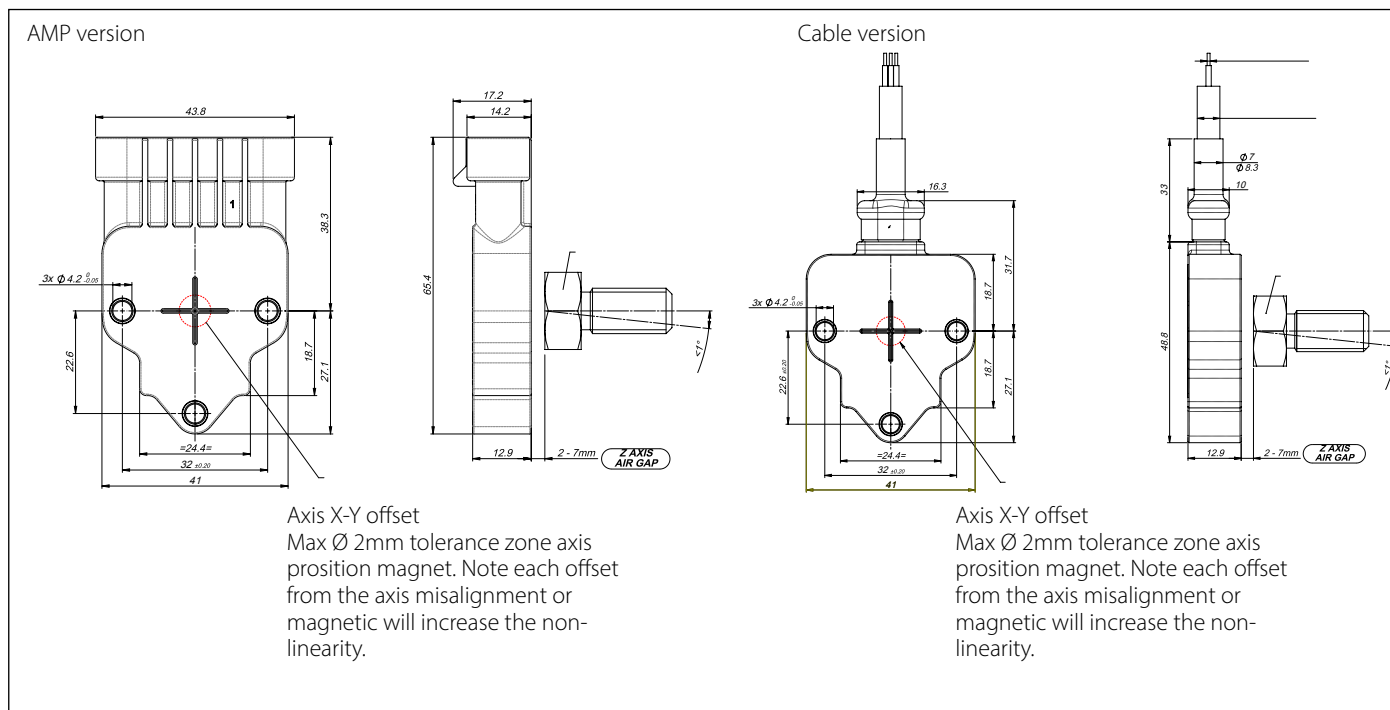

Magnets models

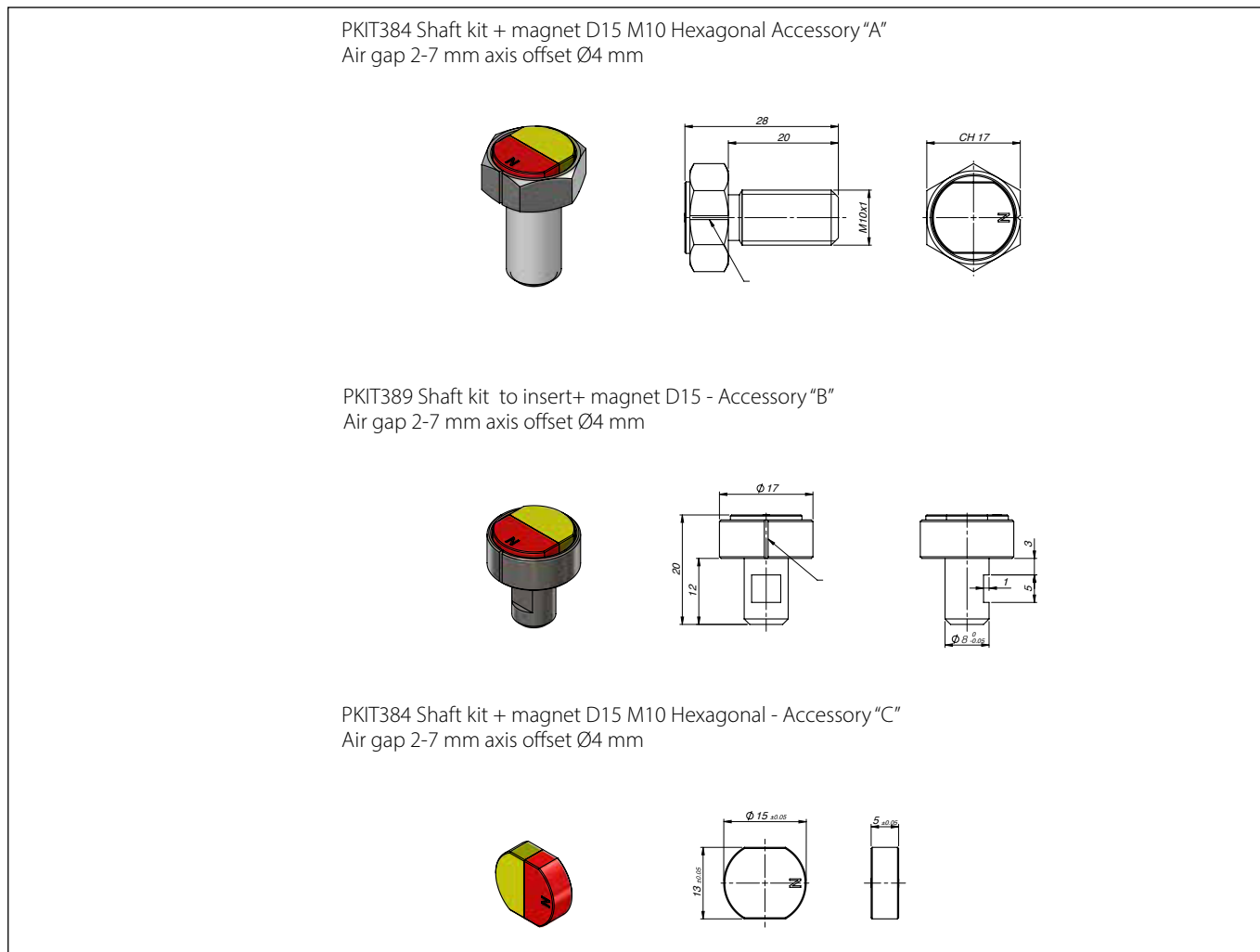

Electrical connections

AMP version

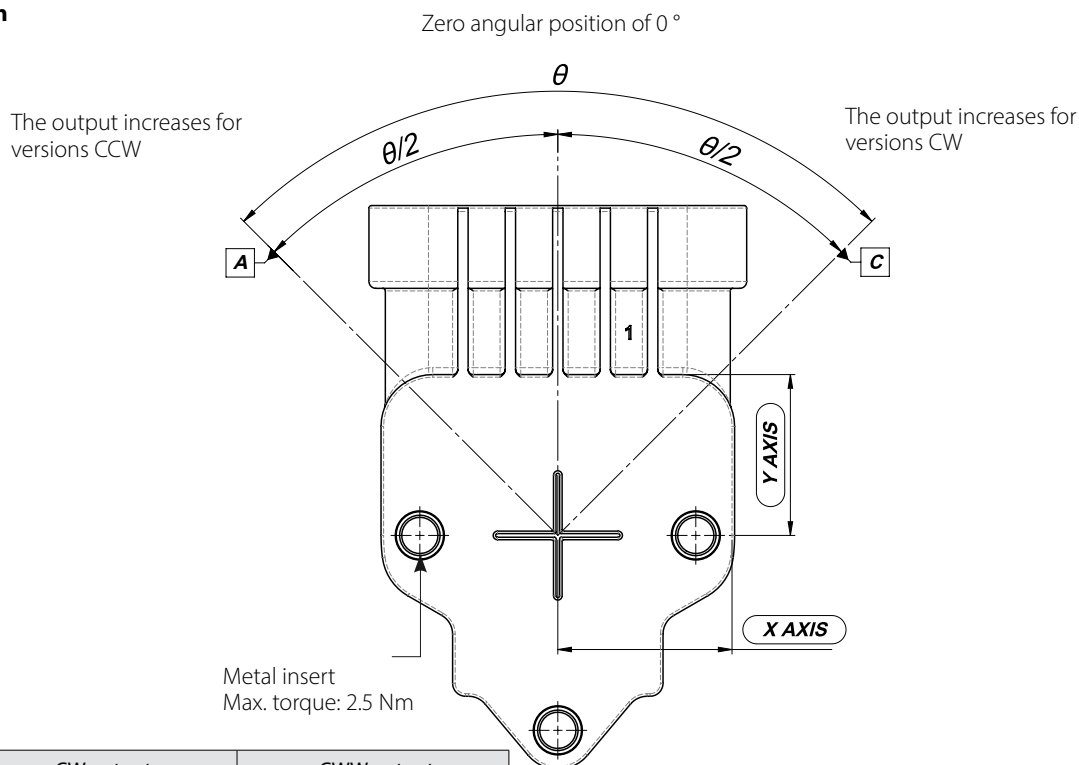

Ref.	CW output	CWW output
A	0.5 V DC	4.5 V DC
B	Zero angular position of 0°	Zero angular position of 0°
C	4.5 V DC	0.5 V DC

Cable version

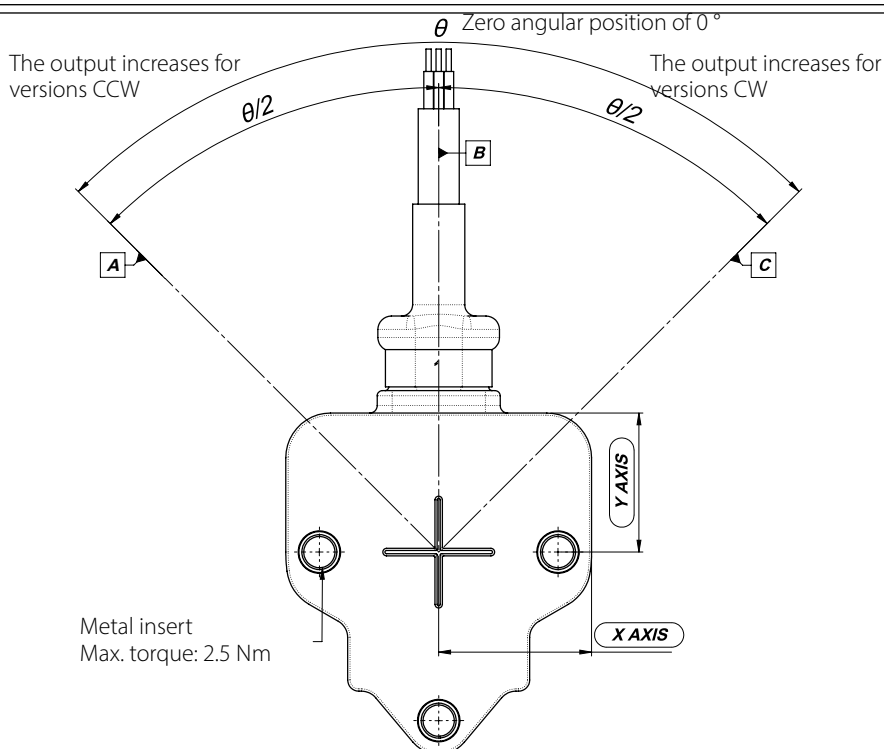

Ref.	CW output	CWW output
A	0.5 V DC	4.5 V DC
B	Zero angular position of 0°	Zero angular position of 0°
C	4.5 V DC	0.5 V DC

AMP version

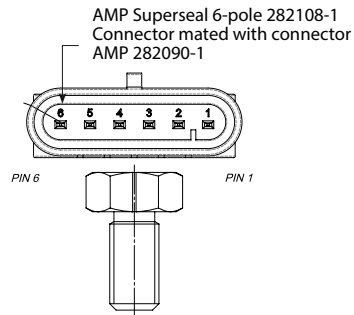

Connections

1. Ground 1
2. + Supply 1
3. Output 1
4. Ground 2
5. + Supply 2
6. Output 2

Connections - CAN/J 1939

1. OV (GND)
2. + Vs (+9 - 36 V DC)
3. GND
4. GND
5. CAN-L
6. CAN-H

Cable version

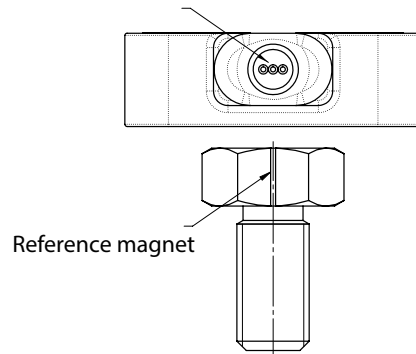

Connections

- Black: Ground 1
- Red: + Supply 1
- Yellow: Output 1
- Green: Ground 2
- Blue: + Supply 2
- White: Output 2

Connections - CAN/J 1939

- Black: Ground 1
- Red: + Supply 1
- Yellow: NC
- Green: NC
- Blue: CAN-L
- White: CAN-H

Cable + M12 version

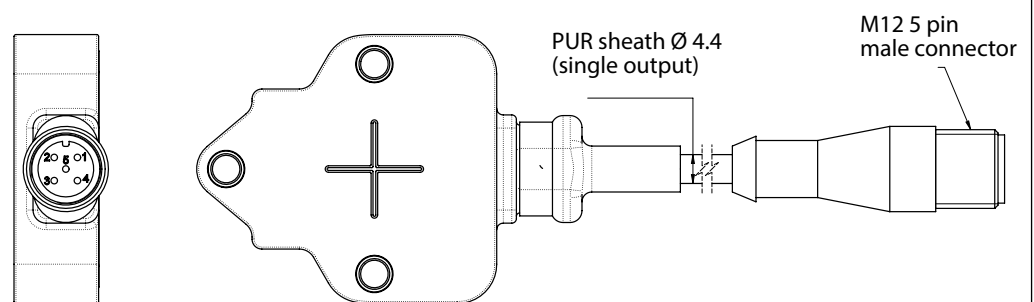

Connections

1. Ground 1
2. + Supply 1
3. Output 1
4. NC
5. NC