

Data sheet

# Low pressure transmitter for marine applications

## MBS 9300



Compact pressure transmitter programme, MBS 9300 gauge version is designed for use in marine applications e.g. crankcase and turbocharger filters monitoring as well as applications within level measurement.

The programme covers 4 – 20 mA and ratiometric 10-90% of supply output signals, pressure span from 40 – 400 mbar as well as bidirectional ranges.

Excellent vibration stability, robust construction, and a high degree of EMC/EMI protection equip the pressure transmitter to meet the most stringent industrial requirements.

### Features

- Compact design
- Full scale span from 40 – 400 mbar
  - bidirectional ranges available, e.g. -40 – 70 mbar etc.
  - lowest zero point –150 mbar
  - max full scale 250 mbar
- Digital temperature compensated
- Output signals 4-20 mA and Ratiometric 10-90% of supply
- Excellent shock and vibration robustness
- Reverse polarity protection
- With build-in clipping function and self-diagnostic features on request
- Enclosure and wetted parts of stainless steel (AISI 316L)
- EU RO Mutual Recognition
- Customer specific versions on request
- For use in Zone 2 explosive atmosphere

### Approvals

DNV GL EU RO Mutual Recognition.  
Lloyds Register of Shipping, LR  
Registro Italiano Navale, RINA  
Bureau Veritas, BV  
American Bureau of Shipping, ABS  
Korean Register of Shipping, KR

**Technical data**
**Performance (EN 60770)**

						Units
Full-scale span (FSS)	40	60	100/140	150	250/400	mbar
Accuracy @ 25 °C (incl. non-linearity, hysteresis and repeatability)	≤ ± 2	≤ ± 1.5	≤ ± 1	≤ ± 0.5	≤ ± 0.5	% FSS typ.
Non-linearity (BFSL)	≤ ± 0.2	≤ ± 0.2	≤ ± 0.2	≤ ± 0.2	≤ ± 0.2	% FSS
Hysteresis and repeatability	≤ ± 0.1	≤ ± 0.1	≤ ± 0.1	≤ ± 0.1	≤ ± 0.1	% FSS
Total error band (TEB) within compensated temperature range	≤ ± 5	≤ ± 3	≤ ± 2	≤ ± 1.5	≤ ± 1.5	% FSS
Mounting position error for 180° rotation	≤ ± 1.25	≤ ± 0.8	≤ ± 0.5	≤ ± 0.35	≤ ± 0.2	% FSS
Overload pressure (static)	3.5	3.5	3.5	3.5	3.5	bar
Burst pressure	50	50	50	50	50	bar
Response time						< 2 ms
Resolution						Infinite
Durability P: 10 – 90% FS						10 × 10 <sup>6</sup> pressure cycles

Full-Scale Span (FSS) is the difference between the upper limit and the lower limit of the pressure range.  
(e.g. for pressure range -30 – 30 mbar, FSS = 60 mbar.)

**Electrical specifications**

Nom. output signal (short circuit protected)	4 – 20 mA	Ratiometric 10-90% supply
Supply voltage [U <sub>B</sub> ], reverse polarity protected	9 – 32 V DC	5 V DC +/- 10%
Supply voltage dependency	< ± 0.05% FSS / 10 V	-
Load [R <sub>L</sub> ] (load connected to 0V)	R <sub>L</sub> ≤ (U <sub>B</sub> - 8 V) / 0.02 A	R <sub>L</sub> ≥ 1.5 kΩ
Supply current consumption	-	≤ 6 mA
Sink / Source	-	3.3 mA
Output impedance	-	≤ 25 Ω

**Environmental specifications**

Media temperature range	FPM gasket	-20 – 100°C
	NBR gasket	-25 – 85 °C
Ambient temperature range	See page 3	
Compensated temperature range	0 – 80 °C	
Transport / storage temperature range	-40 – 125 °C	
EMC - Emission	EN 61000-6-3 and EN61236-1	
EMC Immunity	EN 61000-6-2 and EN61236-1	
Vibration stability	Sinusoidal	15.9 mm-pp, 2 Hz – 25 Hz 20 g, 25 Hz – 2 kHz
	Random	7.5 g <sub>rms</sub> , 5 Hz – 1 kHz
Shock resistance	Shock	500 g / 1 ms
	Free fall	1 m
Enclosure (depending on electrical connection)	See page 3	

**Explosive atmospheres**

Zone 2 applications <sup>1)</sup>	<b>II 3G</b> <b>Ex nA IIA T3 Gc</b> <b>-10 °C &lt; Ta &lt; +85 °C</b>	EN60079-0; EN60079-15
-----------------------------------	---	-----------------------

<sup>1)</sup> When used in ATEX Zone 2 areas at low temperatures the cable and plug must be protected against impact.

**Mechanical specifications**

Net weight	0.2 – 0.3 kg
Electrical connector	See page 3
Pressure connection	see page 3
Materials, wetted parts	EN 10088; 1.4404 (AISI 316 L)

**Dimensions / Combinations**

Type code: Electrical connection	A1	A6	A9
	EN 175301-803-A, Pg 9	EN 175301-803-A, Pg 11	EN 175301-803-A, Pg 13.5
Type code: Pressure connection	FA09 DIN 3852-E-M 14x1.5, Gasket: DIN 3869-14	GB08 DIN 3852-E-G½ Gasket: DIN 3869-21	GB04 DIN 3852-E-G1/4 Gasket: DIN 3869-14
Recommended torque:	20 – 25 Nm		

**Electrical connection**

Type code:	A0, A1, A6 and A9
	EN 175301-803-A
Ambient temperature	-25 – 100 °C (ATEX zone 2 = -10 – 85 °C)
Enclosure	IP65
Materials	Glass filled polyamid, PA 6.6
Electrical connection 4 –20 mA (2 wire)	Pin 1: + supply Pin 2: - supply Pin 3: Not used Earth: Connected to transmitter enclosure
Electrical connection Ratiometric 10 - 90% of supply	Pin 1: + supply Pin 2: - common Pin 3: Output Earth: Connected to transmitter enclosure

For proper ventilation of atmospheric reference pressure a vented cable is recommended.

**Recommended mounting position**

*Error due to different mounting than recommended can be eliminated by zeroing in user hardware*

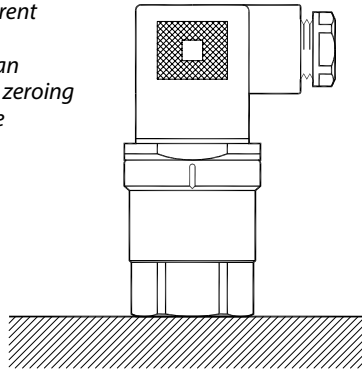

*See mounting position error for 180° rotation on page 2*

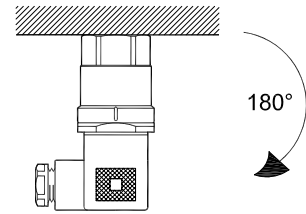

Danfoss  
60C476.10

**Ordering**

Type 9300		Gasket	
<b>Pressure range</b>		1	Gasket, FPM
-20 – 20 mbar	A 1	2	Gasket, NBR
-30 – 30 mbar	A 2		
-70 – 70 mbar	A 3		
0 – 40 mbar	B 1		
0 – 60 mbar	B 2		
0 – 100 mbar	B 3		
0 – 150 mbar	B 4		
0 – 250 mbar	B 5		
<b>Pressure reference</b>			<b>Pressure connection</b>
Gauge (relative)	1	G B 0 8	DIN 3852-E-G1/2, gasket DIN 3869-21
<b>Output signal</b>		G B 0 4	DIN 3852-E-G1/4, gasket DIN 3869-14
4 - 20 mA	1	F A 0 9	DIN 3852-E-M14 x1.5, gasket DIN 3869-14
Ratiometric 10 - 90% of supply	6		
			<b>Electrical connection</b>
		A 0	No plug (EN175301-803-A)
		A 1	Plug Pg 9 (EN 175301-803-A)
		A 6	Plug Pg 11 (EN175301-803-A)
		A 9	Plug Pg 13.5 (EN175301-803-A)

Non-standard build-up codes on request. However, minimum order quantities may apply. Please contact your local Danfoss office for further information.