

MCI 15BP Soft Start Motor Controller

DK
UK

Montering - Mounting - Montage

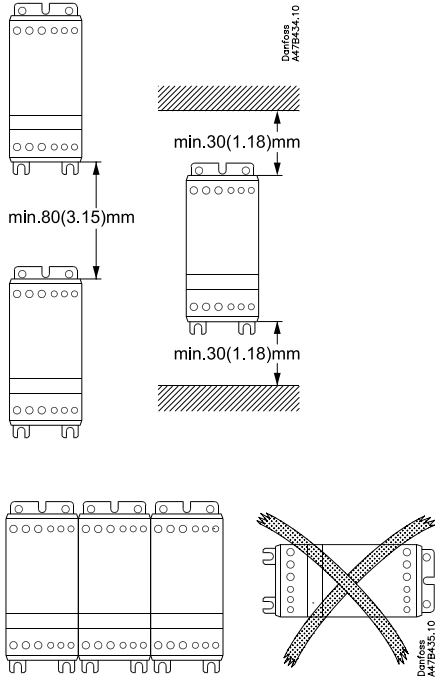

Mål - Dimensions - Abmessungen

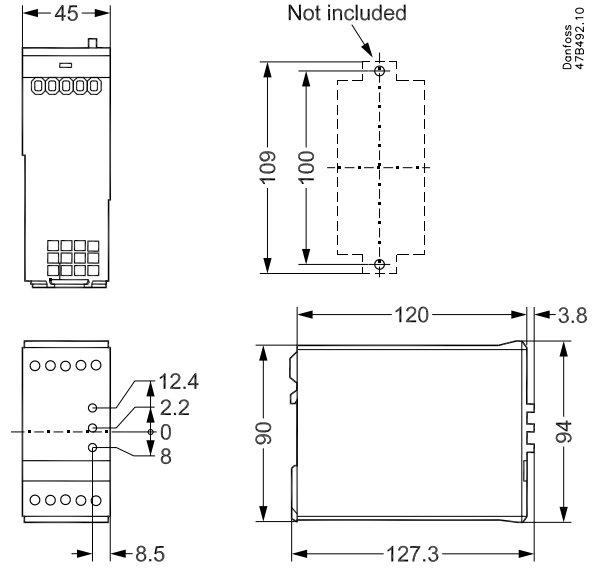

- ! DK Luftstrøm må ikke blokeres
 UK Airflow should not be blocked
 D Luftstrom muß ungehindert fließen

Forbindelse - Wiring - Verdrahtung

75°C		
Kabel/Wire	mm ² (AWG)	mm ² (AWG)
	0.75 - 4 (18 - 12)	0.5 - 1.5 (20 - 16)
	2 x 1 (2 x 18)	2 x 0.5 - 0.75 (2 x 20 - 18)
	0.75 - 6 (18 - 10)	0.5 - 1.5 (20 - 16)
	2 x 0.75 - 2.5 (2 x 18 - 14)	2 x 0.5 - 1.5 (2 x 20 - 16)
	0.75 - 6 (18 - 10)	0.5 - 1.5 (20 - 16)
	2 x 0.75 - 1.5 (2 x 18 - 16)	2 x 0.5 - 1.5 (2 x 20 - 16)
	Pozidrive 1 0.5 Nm max. 4.4 lb-in max.	N.A.
	4 mm 0.5 Nm max. 4.4 lb-in max.	3 mm 0.4 Nm max. 3.5 lb-in max.

- **Vigtigt:** (Overhold max. skruedrejningsmomenter)
 - **Important:** (Observe the maximum screw torque limits)
 - **Wichtig:** (Max. Drehmoment beachten)

Info for UK customers only: Danfoss Ltd. Oxford Road, UB9 4LH Denham, UK

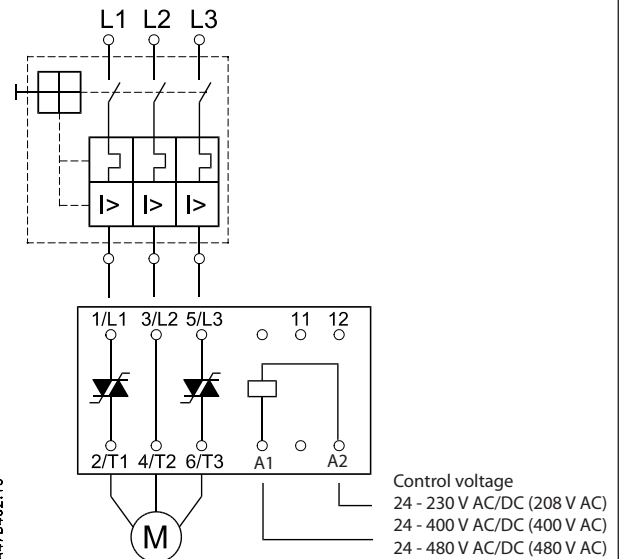

Do not connect power factor correction capacitors to the output.

PS: This product has been designed for class A equipment. Use of the product in domestic environment may cause radio interference, in which case the user may be required to employ additional mitigation methods.

MCI 15BP Soft Start Motor Controller

Indstilling - Settings - Einstellungen

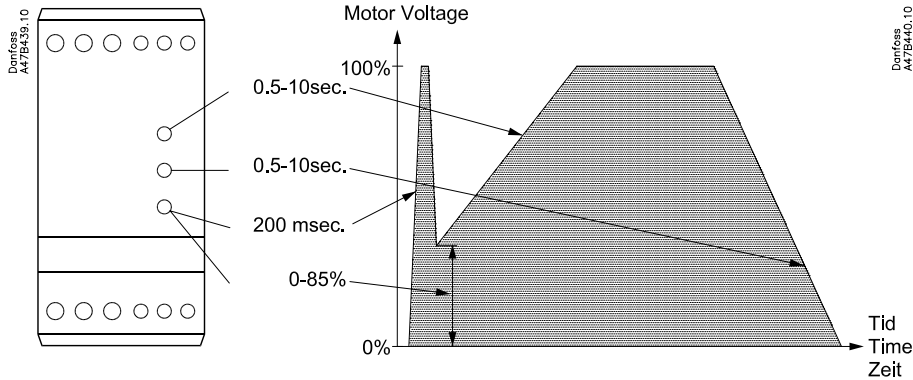

Bemærkninger - Remarks - Bemerkungen

	Dansk	English	Deutsch
NB!	<ul style="list-style-type: none"> Anvend 2 mm x 0.5 mm skruetrækker. Vær forsigtig ikke at indstille drejekontakterne imellem klik. Motor Controlleren aflæser tid og moment justeringen i stop tilstand. 	<ul style="list-style-type: none"> Use 2 mm x 0.5 mm screwdriver. Make sure that the switches click into position, otherwise time and torque settings will not be correct. The motor controller will read time and torque settings in the off state. Repeated starts may trip motor protection relay. 	<ul style="list-style-type: none"> Schraubenzieher 2 mm x 0.5 mm verwenden. Schalter müssen einrasten, um korrekte Funktion zu gewährleisten. Eingestellte Werte werden im ausgeschalteten Zustand abgelesen. Mehrfache Starts können Motorschutzrelais auslösen.

Startmoment indstilling - Initial torque setting - Einstellung der Startleistung

	<ol style="list-style-type: none"> Indstil Ramp-up kontakt til max. indstil Ramp-down kontakt til min. Indstil Initial Torque kontakt til min. Påtryk signalspænding i et par sekunder, hvis ikke motoraksel roterer øjeblikkelig efter start juster Initial torque en deling op. Gentag indtil motoraksel roterer øjeblikkelig efter start. 	<ol style="list-style-type: none"> Set Ramp-up switch to max. Set Ramp-down switch to min. Set Initial torque switch to min. Apply control signal for a few seconds. If the load does not rotate immediately increase the Initial torque for one step and try again. Repeat until the load starts to rotate immediately on start up. 	<ol style="list-style-type: none"> Ramp-up Schalter auf max. stellen Ramp-down Schalter auf min. stellen Initial torque Schalter auf min. stellen Steuersignal einige Sekunden betätigen. Falls der Motor nicht sofort anläuft Initial torque schrittweise erhöhen, bis der Motor anläuft.
	<p>Hvis Initial torque justeringen ikke er tilstrækkeligt til at starte motoren, er det nødvendigt at anvende Kick-start.</p> <ol style="list-style-type: none"> Indstil Ramp-up tiden til max. Indstil Ramp-down tiden til min. Indstil Initial torque til minimum kick-start moment. Påtryk signalspænding i et par sekunder. Hvis belastningen stopper umiddelbart efter Kick-start perioden juster Initial torque en deling op. Gentag indtil motoraksel fortsætter med at rotere efter Kick-start perioden. 	<p>If the maximum Initial torque setting is not sufficient to start the motor, it is necessary to use Kick-start</p> <ol style="list-style-type: none"> Set Ramp-up switch to max. Set Ramp-down switch to min. Set Initial torque switch to min. kick start torque. Apply control signal for a few seconds. If the load stops right after the kick start increase the Initial torque for one step and try again. Repeat until the load continues to rotate after the "kick". 	<p>Falls Initial torque max. Einstellung nicht ausreicht um den Motor zu starten, muß Kick-start verwendet werden.</p> <ol style="list-style-type: none"> Ramp-up Schalter auf max. stellen Ramp-down Schalter auf min. stellen Initial torque Schalter auf min. Kick-start stellen. Steuersignal einige Sekunden betätigen. Falls der Motor sofort wieder stoppt, Initial torque schrittweise erhöhen, bis der Motor sofort nach dem "Kick" anläuft.

Start rampe indstilling - Ramp up settings - Einstellung der Startanstiegszeit

	<ol style="list-style-type: none"> Indstil Ramp-up tiden til max. og start motor. Gradvis nedsæt Ramp-up tiden indtil motor og belastning netop overbelastes. Juster Ramp-up tiden en deling op. 	<ol style="list-style-type: none"> Set Ramp-up switch to max. and start motor. Decrease the Ramp-up time until mechanical surge is observed. Increase Ramp-up time one step. 	<ol style="list-style-type: none"> Ramp-up Schalter auf max. stellen. Ramp-up Zeit solange verkürzen bis Überbelastung beobachtet wird. Ramp-up Zeit um einen Schritt erhöhen.
--	--	--	--

Stop rampe indstilling - Ramp down settings - Einstellung der Startanstiegszeit

	<ol style="list-style-type: none"> Indstil Ramp-down tiden til max. og afbryd signalspændingen. Gradvis nedsæt Ramp-down tiden indtil motor og belastning netop overbelastes. Juster Ramp-down tiden en deling op. 	<ol style="list-style-type: none"> Set Ramp-down switch to max. and switch off the control voltage. Decrease the Ramp-down time until mechanical surge is observed. Increase Ramp-up time one step. 	<ol style="list-style-type: none"> Ramp-down Schalter auf max. stellen und Steuersignal ausschalten. Ramp-down Zeit solange verkürzen bis Überbelastung beobachtet wird. Ramp-down Zeit um einen Schritt erhöhen.
--	--	---	---