



Solenoid Valves Technical Information

2 Way, 2 Position Spool

SV15-22-01



OPERATION

Solenoid Valve, Spool Type, 2-Position, 2-Way, Normally Open, Pull-Type, High Flow (15-Size). When de-energized, the SV15-22-01 allows flow in both directions. When energized, flow is blocked in both directions. Follow the "Operating Envelope" limits to ensure shifting of the valve during operation. This valve is a direct replacement for EDH 12/NA and uses a metric M33x2 cavity (NCS 12/2) for high flow capability.



Shown with Standard Coil,
DIN Connector

APPLICATIONS

These spool-type valves are primarily used in mobile and industrial applications for blocking the flow of a 2-way function, pump unloading or cylinder regeneration. Solenoid spool-type valves are direct acting and respond quickly to coil voltage input. Spool valves will have some leakage due to spool clearance, so if your application requires no leakage at the working port(s), apply a low leakage poppet valve(s), like PO check valve, counterbalance valve, etc., in addition to this solenoid valve. This valve can operate with an inlet pressure of 315 bar for 100,000 cycles. In case of inlet from port 2 this value can be increased to 300,000 cycles.

SPECIFICATIONS

Rated Pressure*	210 bar [3000 psi]**
Maximum Rated Flow at 7 bar [100 psi]	60 l/min [16 US gal/min]
Weight including coil	0.65 kg [1.65 lbs]
Cavity	NCS 12/2
Coil	M19 33 Watt
Diode (Optional)	Unidirectional

* Rated Pressure based on NFPA fatigue test standards (at 1 Million Cycles).

** See 315 bar pressure rating note on page 10.

SCHEMATIC

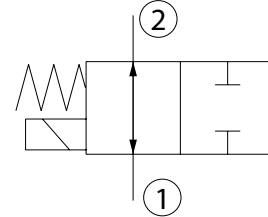

PERFORMANCE CURVES

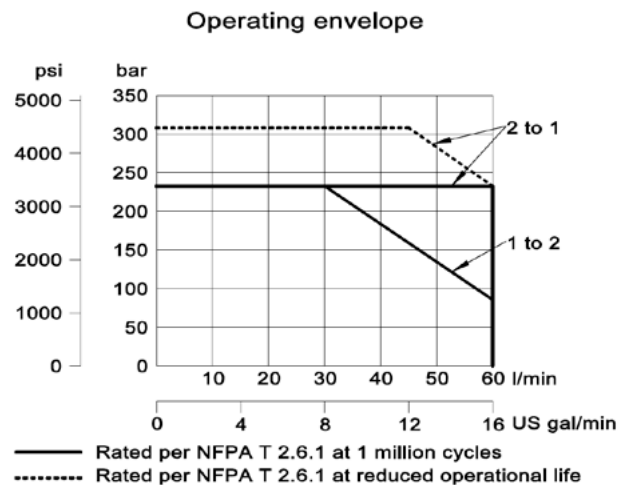
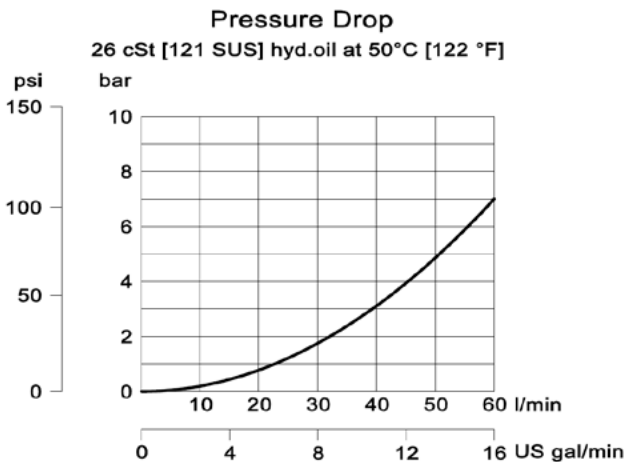

DIMENSIONS

mm [in]

Cross-sectional view

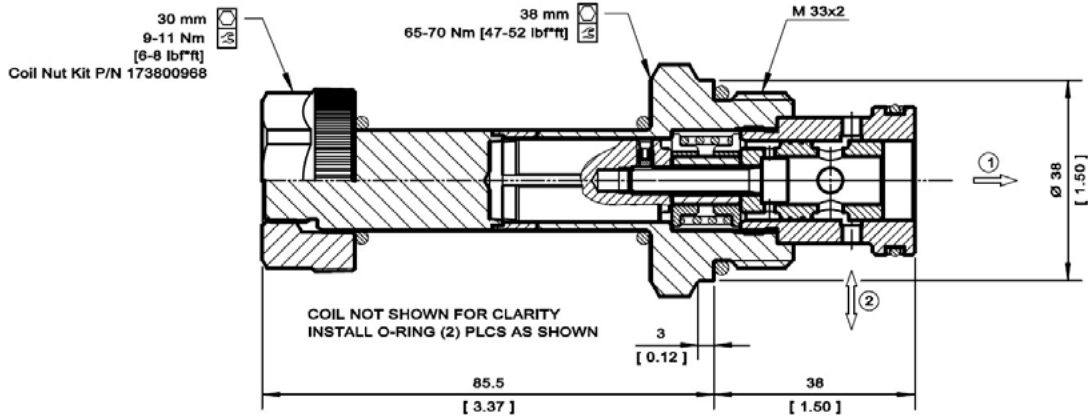

EXAMPLE CIRCUITS

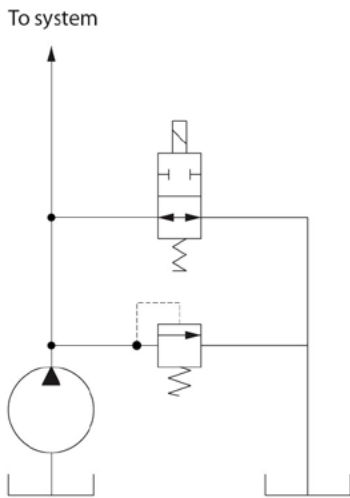

Cylinder regeneration circuit

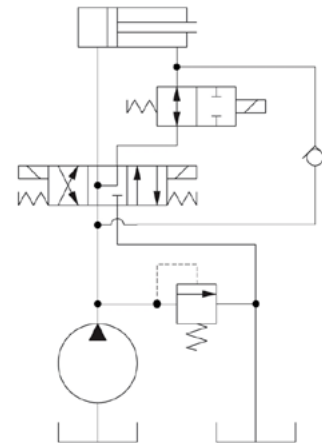

Energize 2-way spool valve for faster extension

ORDERING INFORMATION

SV15 - 22 - 01 - 12D - DE - B - 00

Solenoid Valve, Spool
Type, 15 Size Cavity

22:
2 Position, 2 Way

01:
Schematic type –
Normally Open

Coil Voltage	Standard Coil Code
No Coil, with nut*	00
10 VDC	10D
12 VDC	12D
20 VDC	20D
24 VDC	24D
110 VAC**	110A
220 VAC**	220A

* Standard coil – plastic nut and O-rings
** External Rectifier Needed – DN termination only

Code	Body and Ports	Body Nomenclature
00	Cartridge Only	No Body
8S	#8 SAE, AL	NCS 12/2-DG-8S
12S	#12 SAE, AL	NCS 12/2-DG-12S
4B	1/2 BSP, AL	NCS 12/2-DG-1/2
6B	3/4 BSP, AL	NCS 12/2-DG-3/4

Seal Code	Material	Seal Kits
B	Buna-N	11115411
V	Viton	11115413

Coil Termination	Standard Coil Code	IP Rating
No Coil	00	-
Amp Junior	AJ	IP67
Amp Junior with Diode	AJD	IP67
Deutsch	DE	IP67
Deutsch with Diode	DED	IP67
Flying Leads	FL	IP65
DIN 46650	DN	IP65