

Data Sheet

Solenoid valve

Type **EV210B** and **EV210BW**

Direct-operated 2/2-way solenoid valves for universal use.

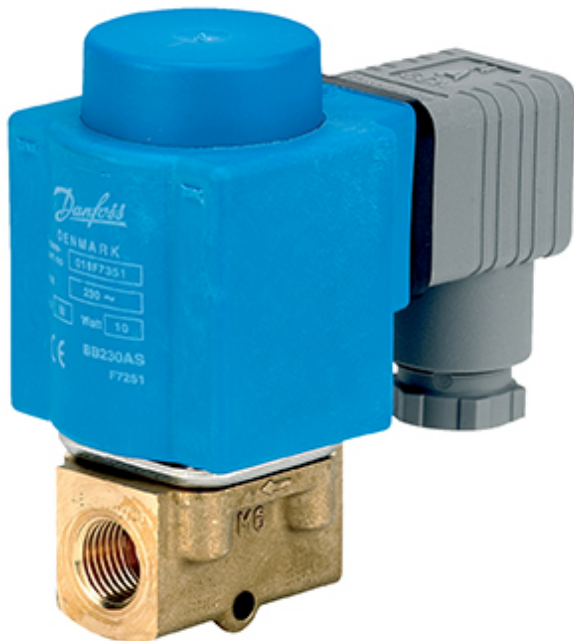

EV210B and EV210BW covers a wide range of direct-operated 2/2-way solenoid valves for universal use.

EV210B and EV210BW are a very robust valves program with high performance and can be used in all kind of tough working conditions in demanding industrial applications such as control and closure.

Features and versions:

- For water, oil, compressed air and similar neutral media
- Clip on coil
- Ambient temperature: up to 80 °C
- Coil enclosure : up to IP67
- The valves can be used for vacuum
- EV210B brass version for water, oil, compressed air and similar neutral media
- EV210B stainless steel version for neutral and aggressive liquids and gasses
- EV210BW brass and Stainless steel versions, EPDM seal and WRAS approved for drinking water

1 Portfolio overview

Table 1: Portfolio overview

Features	EV210B	EV210BW	EV210B	EV210BW
				
Body material	Brass	Brass	Stainless steel	Stainless steel
DN [mm]	1.5 – 25	1.5-4.5	2-3	1.5-4.5
Connection	G 1/8 – G 1	G 1/8-G 3/8	G 1/8-G 1/4	G 1/4
Sealing material	EPDM, FKM	EPDM	EPDM	EPDM
Function	NC, NO	NC	NC	NC
Kv [m³/h]	0.08-8.00	0.08-0.55	0.15-0.30	0.08-0.55
Differential pressure range [bar]	0 – 30	0-16	0-30	0-16
Temperature range [°C]	-30 – 120	-30-90	-30-120	-30-90

2 Functions

2.1 Function NC

Coil voltage disconnected (closed):

When the voltage to the coil (5) is disconnected, the armature (2) with the valve plate (3) is pressed down against the valve orifice (4) by the closing spring (1) and the medium,s pressure.

The valve will be closed for as long as the voltage to the coil is disconnected.

Coil voltage connected (open):

When voltage is applied to the coil(5), the armature (2) with the valve plate (3) is lifted clear of the valve orifice (4).

The valve is now open for unimpeded flow and will be open for as long as there is voltage to the coil.

Figure 1: Function NC

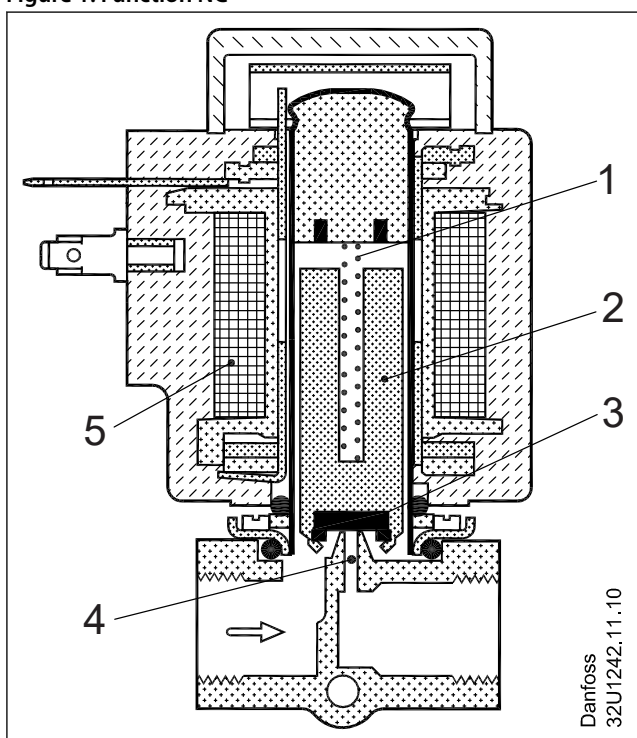

1	Closing spring
2	Armature
3	Valve plate
4	Valve orifice
5	Coil

2.2 Function NO

Coil voltage connected (open):

When the voltage to the coil(8) is disconnected, the valve orifice (5) is open, the opening spring (2) lifting the spindle (3) with the valve plate (4) clear of the orifice.

The valve will be open for as long as the supply voltage to the coil is disconnected.

Coil voltage disconnected (closed):

When voltage is applied to the coil (8), the magnetic field draws the valve,s armature (1) down to touch the fixed base(7). The spindle (3) with the valve plate (4) is now pressed down against the valve orifice (5) by the closing spring (6).

The valve will be closed for as long as there is voltage to the coil.

Figure 2: Function NO

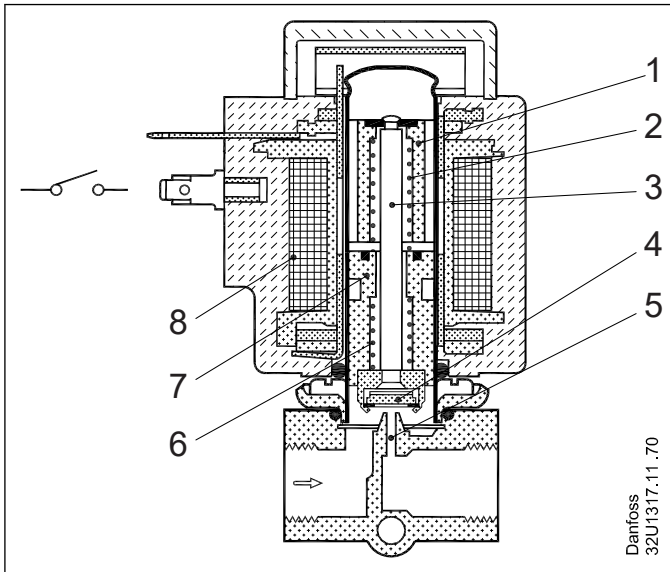

1	Armature
2	Opening spring
3	Spindle
4	Valve plate
5	Valve orifice
6	Closing spring
7	Fixed base
8	Coil

3 Applications

It is recommended to use a filter in front of the valve. Recommended filter 50 mesh (297 microns).

Figure 3: Filter

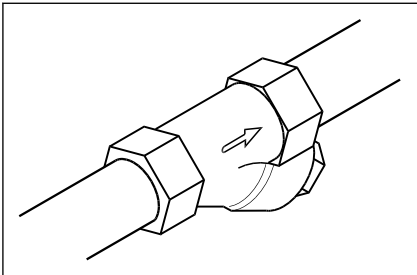

In water applications, exercise the valves at least once every 24 hours, meaning change the state of the valve. The valve exercise will minimize the risk of the valve sticking due to calcium carbonate, zinc or iron oxide build-up.

Figure 4: Exercise: Valve on/off

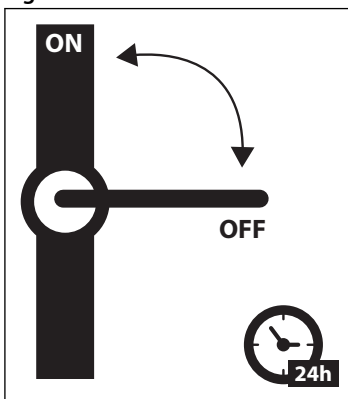

To minimize scaling, and corrosion attack it is recommended that the water passing the valve have the following values:

- Hardness 6 - 18 °dH to avoid scaling (chalk / lime stone build up)
- Conductivity 50 – 800 µS/cm to avoid brass dezincification and corrosion
- Above 25 °C media temperature avoid stagnant water inside the valve to avoid dezincification and corrosion attack

4 Product specification

4.1 Technical data

Table 2: Technical data

Media	EV210B brass	FKM	For oil, compressed air
		EPDM	For water
	EV210B stainless	EPDM	For neutral and aggressive liquids and gasses for neutral and aggressive liquids and gasses
	EV210BW	WRAS approved EPDM	Drinking water
Media temperature [°C]	EPDM		-30 - 120 °C
	FKM		-10 - 100 °C
	EV210BW EPDM		-30 - 90 °C (WRAS approved to 23 °C)
Ambient temperature [°C]	Up to 80 °C		
Kv value [m³/h]	DN1.5		0.08 m ³ /h
	DN2		0.15 m ³ /h
	DN3		0.30 m ³ /h
	DN4.5		0.55 m ³ /h
	DN6		0.70 m ³ /h
	DN8		1 m ³ /h
	DN10		1.50 m ³ /h
	DN15 (G ³ / ₈)		2.50 m ³ /h
	DN15 (G ¹ / ₂)		2.85 m ³ /h
	DN20		4.50 m ³ /h
DN25		8.00 m ³ /h	
Min. Opening differential pressure [bar]	0 bar		
Max. Opening differential pressure [bar]	Up to 30 bar		
Max. working pressure [bar]	Up to 30 bar (Equal to max. differential pressure)		
Max. test pressure [bar]	DN1.5 - 4.5		52.5 bar
	DN6 - 10		37.5 bar
	DN15 - 25		24 bar
Pressure	Pressure range can be extended to use in rough vacuum, typically up to 99% vacuum (10 mbar), depending on the application		
Low pressure steam	140 °C / 3.6 bar low pressure steam, orifice DN 1.5 – 4.5. • Low pressure steam: DN 1.5 – 3 Use coil type BB or BG, DN 4.5 Use coil type BG		
Viscosity [cSt]	Max. 50 cSt		

Capacity diagrams

Example, water at low pressure: Capacity for EV210B 1.5B at differential pressure of 10 mbar. Approx. 0.08 l / min

Figure 5: Water at low pressure

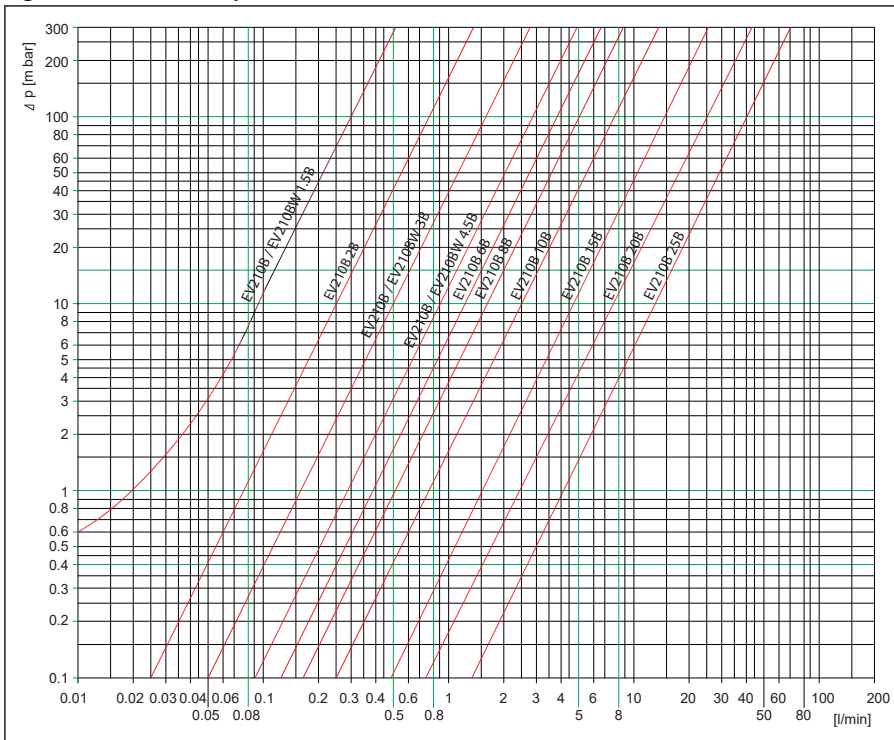

Example, water at higher pressure: Capacity for EV210B 3B at differential pressure of 0.5 bar. Approx. 0.21 m³ / h

Figure 6: Water at higher pressure

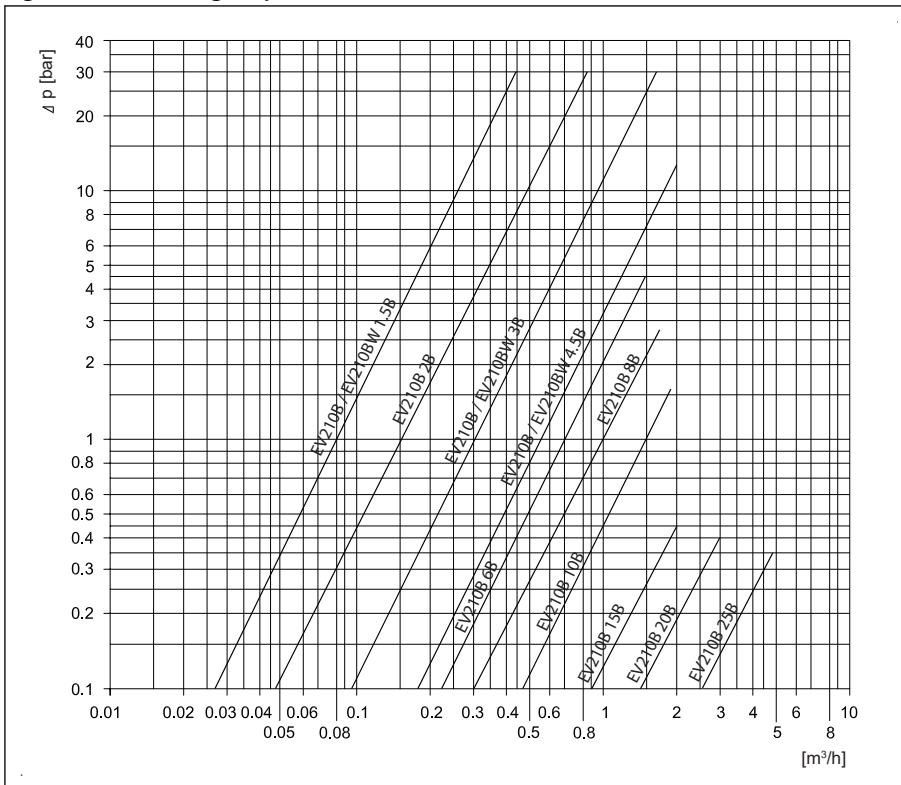

Example, air at lower pressure: Capacity for EV210B 15B at differential pressure of 17 mbar. Approx. 10 Nm³ / h

Solenoid valve, type EV210B and EV210BW

Figure 7: Air at lower pressure

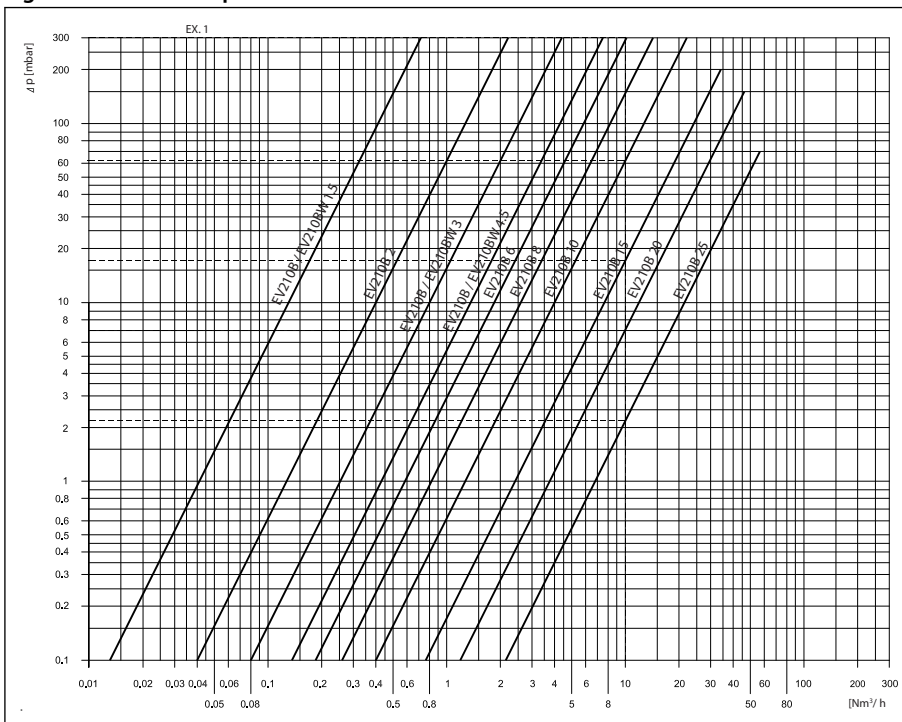

Example, air at higher pressure : Capacity for EV210B 2B at inlet pressure (p_1) of 5 bar and outlet pressure (p_2) of 3.25 bar. Approx. 9 Nm³ / h

Figure 8: Air at higher pressure

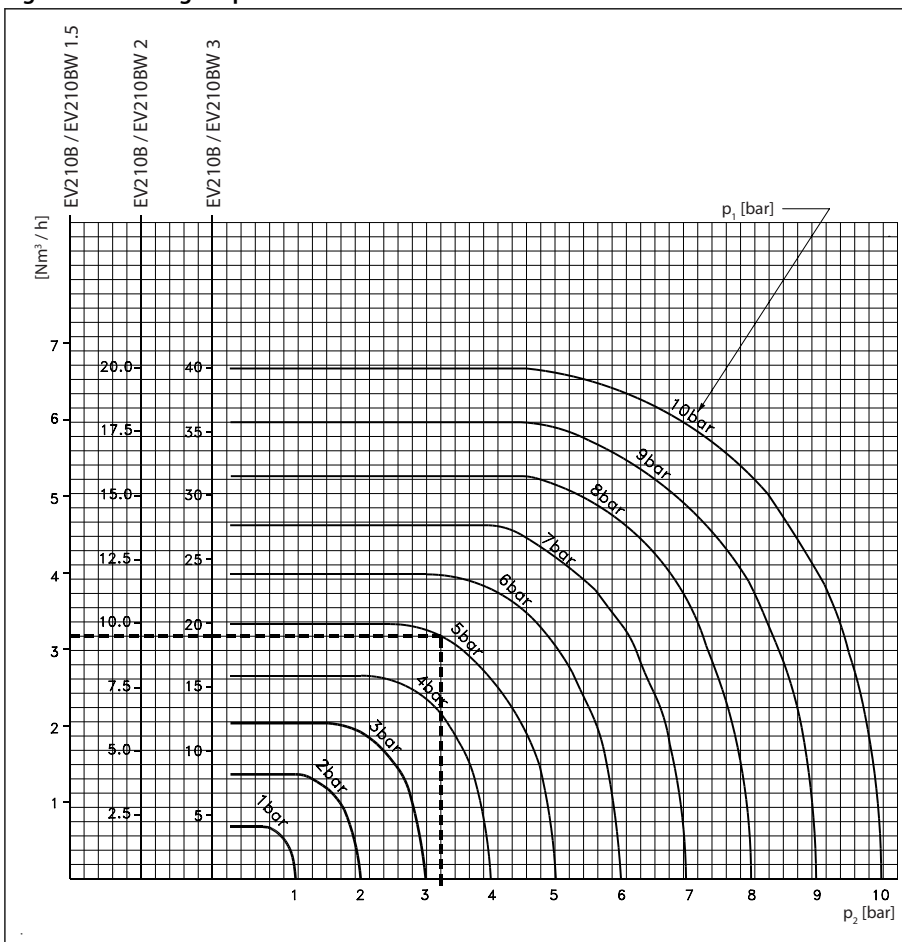

Differential pressure range

Table 3: Differential pressure range, NC

Connection ISO228-1	Orifice size	Approval	Differential pressure min. to max. [bar]							
			NC							
			Suitable coil type							
			BA		BD	BB/BE/BR/BY		BG		
AC	DC	AC	AC	DC	AC	DC				
G $\frac{1}{8}$, G $\frac{1}{4}$	1.5		0-30	0-30	0-30	0-30	0-30	0-30	0-30	
G $\frac{1}{8}$			0-16	0-16	0-16	0-16	0-16	0-16	0-16	
G $\frac{1}{8}$, G $\frac{1}{4}$	2.0		0-30	0-20	0-30	0-30	0-30	0-30	0-30	
G $\frac{1}{8}$, G $\frac{1}{4}$, G $\frac{3}{8}$	3.0		0-15	0-9	0-24	0-20	0-13	0-30	0-25	
G $\frac{1}{4}$, G $\frac{3}{8}$			0-15	0-9	0-16	0-16	0-13	0-16	0-16	
G $\frac{1}{4}$, G $\frac{3}{8}$	4.5		0-8	0-3.5	0-12	0-10	0-4.5	0-13	0-9	
G $\frac{1}{4}$, G $\frac{3}{8}$			0-8	0-3.5	0-12	0-10	0-4.5	0-13	0-9	
G $\frac{1}{4}$, G $\frac{3}{8}$	6.0		0-2.5	0-1	0-3.3	0-4	0-2	0-6	0-4.5	
G $\frac{3}{8}$, G $\frac{1}{2}$	8.0		0-1.5	0-0.5	0-2	0-2	0-1.2	0-3	0-2.5	
G $\frac{3}{8}$, G $\frac{1}{2}$	10.0		0-0.8	0-0.3	0-1.1	0-1.2	0-0.6	0-1.6	0-1.3	
G $\frac{3}{8}$, G $\frac{1}{2}$	15.0		0-2.5		0-0.4	0-0.3	0-0.15	0-0.45	0-0.4	
G $\frac{3}{4}$	20.0					0-0.28	0-0.12	0-0.4	0-0.35	
G1	25.0					0-0.25	0-0.9	0-0.35	0-0.2	

Table 4: Differential pressure range, NO

Connection ISO228-1	Orifice size	Differential pressure min. to max. [bar]							
		NO							
		Suitable coil type							
		BA		BD	BB/BE/BR/BY		BG		
AC	DC	AC	AC	DC	AC	DC			
G $\frac{1}{8}$	1.5	0-30	0-30	0-30	0-30	0-30	0-30	0-30	
G $\frac{1}{8}$, G $\frac{1}{4}$	2.0	0-12	0-12	0-12	0-12	0-12	0-12	0-12	
G $\frac{1}{4}$	3.0	0-5	0-5	0-5	0-5	0-5	0-5	0-5	
G $\frac{1}{4}$	4.5	0-2	0-2	0-2	0-2	0-2	0-2	0-2	

Time to open/close

Table 5: EV210B/BW Brass valve body, NC time to open/close

Type	EV210B/BW 1.5 - 2	EV210B/BW 3-4.5	EV210B 6	EV210B 8 - 10	EV210B 15	EV210B 20	EV210B 25
Time to open [ms] ⁽¹⁾	10	20	20	20	30	40	40
Time to close [ms] ⁽¹⁾	20	20	20	30	50	50	70

⁽¹⁾ The times are indicative and apply to water. The exact times will depend on the pressure conditions.

Table 6: EV210B Brass valve body, NO time to open/close

Type	EV210B 1.5 - EV210B 4.5
Time to open [ms] ⁽¹⁾	20
Time to close [ms] ⁽¹⁾	20

⁽¹⁾ The times are indicative and apply to water. The exact times will depend on the pressure conditions.

Materials

Table 7: Materials

Components	Materials	Specifications
Valve body	Brass/Stainless steel	W.no. 2.0402/W.no. 1.4404 / AISI 316L
Armature	Stainless steel	W.no. 1.4105 / AISI 430 FR
Armature tube	Stainless steel	W.no. 1.4306 / AISI 304 L
Armature stop	Stainless steel	W.no. 1.4105 / AISI 430 FR

Solenoid valve, type EV210B and EV210BW

Components	Materials	Specifications
Springs	Stainless steel	W.no. 1.4310 / AISI 301
Valve plate	EPDM/FKM	
O-ring	EPDM/FKM	

4.2 Dimensions and Weights

Table 8: Dimensions and weight

Type	Weight gross valve body without coil	L	B	B ₁ [mm]			H ₁	H
	[kg]	[mm]	[mm]	Coil type BA / BD	Coil type BB / BE BR / BY	Coil type BG	[mm]	[mm]
EV210B 1.5 / EV210B 2B, NC	0.15	35	34	32	46	67	12	70
EV210B 3 / EV210B 4.5, NC	0.20	38	34	32	46	67	11	70
EV210B 6B, NC	0.22	46	34	32	46	67	16	73
EV210B 8 / EV210B 10B, NC	0.29	49	34	32	46	67	16	73
EV210B 15B, NC	0.45	58	53	32	46	67	13	93
EV210B 20B, NC	1.10	90	58	32	46	67	18	92
EV210B 25B, NC	1.10	90	58	32	46	67	23	96
EV210BW 1.5	0.15	35	34	32	46	67	12	70
EV210BW 3 – 4.5	0.20	38	34	32	46	67	11	70
EV210BW 1.5 / 3 / 4.5	0.25	35	35	32	46	67	11.5	75
EV210B 2 / 3 / 4.5	0.25	35	35	32	46	67	11.5	75

Figure 9: Dimensions, brass body

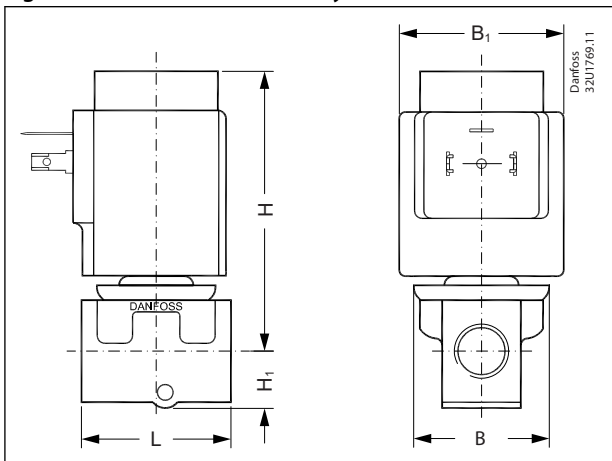
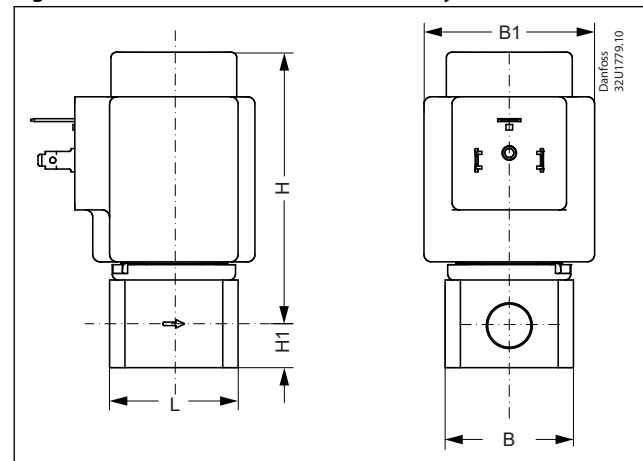
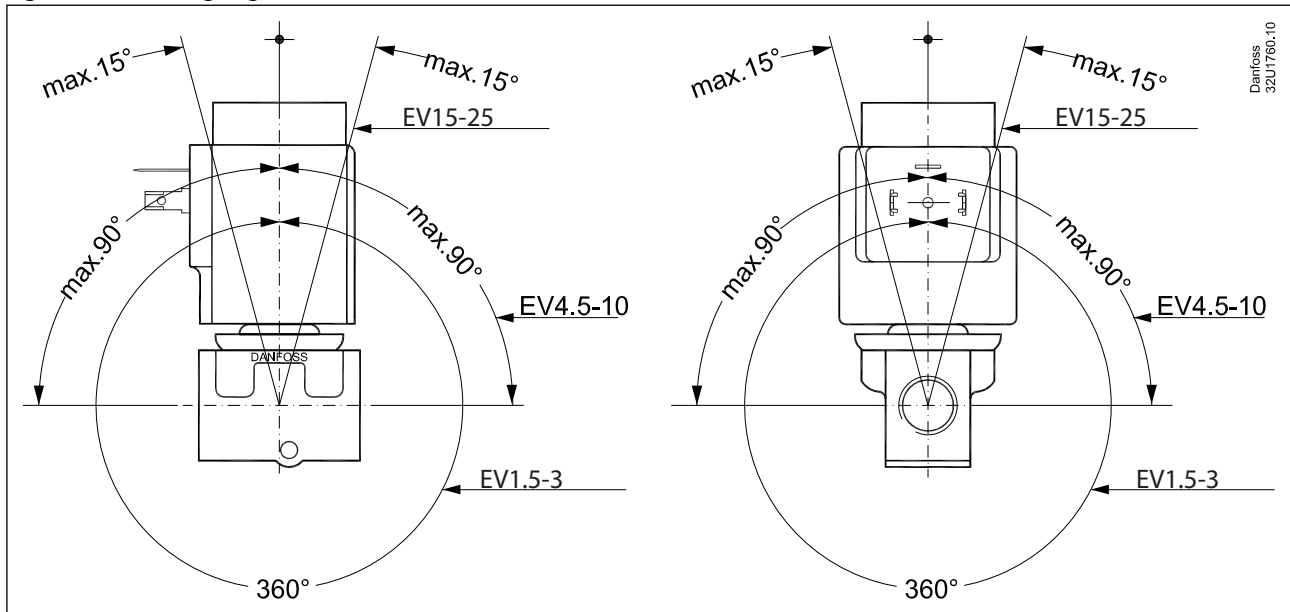

Figure 10: Dimensions, stainless steel body



4.3 Mounting

Figure 11: Mounting angle



5 Ordering

5.1 Parts program





Table 9: Brass/SS, valve body NC and NO

Connection ISO228/1	Orifice	Kv value	Sealing	Function				
				EV210B			EV210BW brass 	
				Brass		SS	Brass	SS
				[mm]	[m³/h]	EPDM/FKM	NC	NO
G ¼	1.5	0.08	EPDM	032U5701	032U3630		132U2102	
			FKM	032U5702	032U3631			
	2.0	0.15	FKM	032U5704	032U3633			
			EPDM		032U3632	032U3647		
	3	0.30	EPDM	032U5705		032U3649		
			FKM	032U5706				
4.5	0.55	EPDM			032U3655			
G ¼	1.5	0.08	FKM	032U3629				
			EPDM					132U2154
	2	0.15	EPDM	032U5707	032U3636	032U3651		
			FKM	032U5708	032U3637			
	3	0.30	EPDM	032U5709	032U3638	032U3653	132U3004	132U3054
			FKM	032U5710	032U3639			
	4.5	0.55	EPDM	032U3600	032U3640		132U4408	132U4452
			FKM	032U3601	032U3641			
6	0.70	EPDM	032U3602					
FKM	032U3603							
G ¾	3	0.30	EPDM	032U3642			132U3006	
			FKM	032U3643				
	4.5	0.55	EPDM	032U3605			132U4404	
			FKM	032U3606				
	6	0.70	EPDM	032U3607				
			FKM	032U3608				
	8.0	1.00	EPDM	032U3609				
			FKM	032U3610				
	10	1.50	EPDM	032U3611				
			FKM	032U3612				
15	2.50	EPDM	032U3613					
		FKM	032U3614					
G ½	8	1.00	EPDM	032U3615				
			FKM	032U3616				
	10	1.50	EPDM	032U3617				
			FKM	032U3618				
	15	2.85	EPDM	032U3619				
			FKM	032U3620				
G ¾	20	4.50	EPDM	032U3621				
			FKM	032U3622				
G 1	25	8	EPDM	032U3623				
			FKM	032U3624				

5.2 Accessories

Coils

Table 10: Below coils can be used for EV210B and EV210BW

Coil	Type	Power consumption	Enclosure	Features
	BA / BD, screw on	8.5 - 15 W AC 14 W DC	IP00 with spade connector	IP20 with protective cap IP65 with cable plug
	BB/BY, clip on	11 - 16 W AC 14 - 16 W DC	IP00 with spade connector	IP20 with protective cap IP65 with cable plug
	BR, clip on	12 - 14 W AC 16 W DC	IP00 with spade connector	IP20 with protective cap, IP65 with cable plug Design for marine application
	BE, clip on	11 - 17 W AC 15 - 16 W DC	IP67	With terminal box
	BG, clip on	11 - 16 W AC 16 - 20 W DC	IP67	With terminal box

Cable plug

Figure 12: Cable plug



Type, Form A	Code number
GDM 2011 (grey) cable plug according to DIN 43650-A PG11	042N0156

Timer

Universal electronic multi-timer, Type ET20M

Figure 13: ET20M



Table 11: Timer

Type	Voltage [V]	Suitable for coil types	Code no.
BA024A	24 – 240	AL, AM, AS, AZ, BA, BD, BB	042N0185

Mounting bracket

For EV210B/BW 1.5 – 4.5B in connection with synthetic tubes, pipes and similar.

Figure 14: Mounting bracket

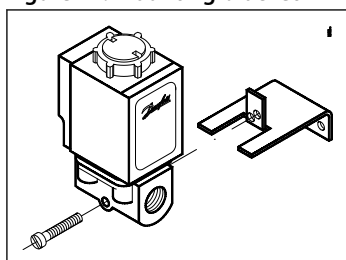

Table 12: Bracket

Description	Code no.
Brackets	032U1040

Isolating diaphragm kit for EV210B 1.5 – 4.5 NC

Avoids build-up of contaminants that can block movement of the armature. Permits use of more aggressive media that would normally attack the armature. Gel filled; guarantees operation after long periods of inactivity. The kit is suitable for orifice sizes up to DN 4.5 mm.

Table 13: Isolating diaphragm kit

Seal material	Media temperature [C°]	Code no.
EPDM	-20 - 50	042U1009
FKM	0 - 50	042U1010

The kit consist of:

- Assembled isolating unit
- O-ring
- 4 screws
- Locking button Nut for coil

Figure 15: Isolating diaphragm kit



Spare parts kit, NC

Table 14: Spare parts

Valve type	Seal material	Code no.
EV210B 1.5, 2, 3, 4.5	FKM	032U2003
EV210B 6, 8, 10	FKM	032U2011
	EPDM	032U2006
EV210B 15	FKM	032U2012
	EPDM	032U2013
EV210B 20	FKM	032U2014
	EPDM	032U2017
EV210B 25	FKM	032U2018
	EPDM	032U2019

The spare parts kit consists of:

- Locking button
- Nut for the coil
- Armature with valve plate and spring
- O-ring

Figure 16: Spare part kit



Spare parts kit, NO

Table 15: Spare parts

Valve type	Seal material	Code no.
EV210B 1.5, 2, 3, 4.5	FKM	032U2004
	EPDM	032U2005

The spare parts kit consists of: Armature tube 2 O-rings

Figure 17: Spare part kit



6 Online support

Danfoss offers a wide range of support along with our products, including digital product information, software, mobile apps, and expert guidance. See the possibilities below.

The Danfoss Product Store



The Danfoss Product Store is your one-stop shop for everything product related—no matter where you are in the world or what area of the cooling industry you work in. Get quick access to essential information like product specs, code numbers, technical documentation, certifications, accessories, and more.

Start browsing at store.danfoss.com.

Find technical documentation



Find the technical documentation you need to get your project up and running. Get direct access to our official collection of data sheets, certificates and declarations, manuals and guides, 3D models and drawings, case stories, brochures, and much more.

Start searching now at www.danfoss.com/en/service-and-support/documentation.

Danfoss Learning



Danfoss Learning is a free online learning platform. It features courses and materials specifically designed to help engineers, installers, service technicians, and wholesalers better understand the products, applications, industry topics, and trends that will help you do your job better.

Create your Danfoss Learning account for free at www.danfoss.com/en/service-and-support/learning.

Get local information and support



Local Danfoss websites are the main sources for help and information about our company and products. Find product availability, get the latest regional news, or connect with a nearby expert—all in your own language.

Find your local Danfoss website here: www.danfoss.com/en/choose-region.

Spare Parts



Get access to the Danfoss spare parts and service kit catalog right from your smartphone. The app contains a wide range of components for air conditioning and refrigeration applications, such as valves, strainers, pressure switches, and sensors.

Download the Spare Parts app for free at www.danfoss.com/en/service-and-support/downloads.