

Data Sheet

Gas detection unit

Accessory

Expansion module

Detecting and warning of hazardous gas concentrations in industrial refrigeration systems

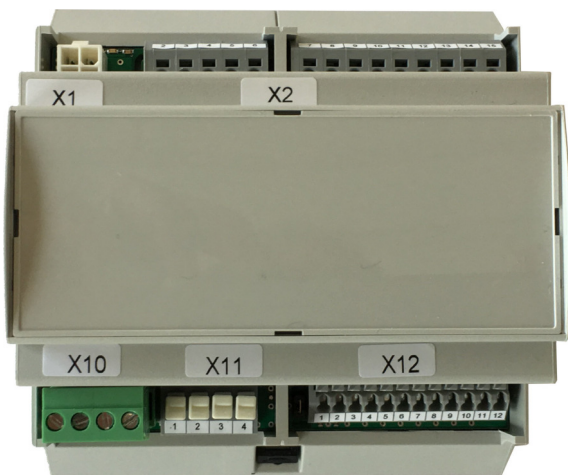

The gas detection Controller Expansion module is used for expansion of the cable coverage in terms of number of fieldbus loops and the total wire length. Each Controller Unit can handle up to 7 Expansion modules allowing 7 additional loops of 900 meters (2953 ft) length available for local Gas Detection Units. Communication between the Controller, the Expansion modules and the Gas Detection Units is done via Analog or RS485 fieldbus.

Additional 4 relays for external looped alarm devices is made available for each Expansion module.

Expansion modules can be installed close to the Controller (Controller Solution) or alternatively in the field.

Features:

- For extension of the covered site area for gas detection sensors
- 4 relays for external alarm device circuits per Expansion module
- Up to 7 Expansion modules per Controller possible; allows additional 7 segments with a total of 7200 meters (23622 ft.) wiring and a total of 32 relays for alarm device circuits
- Flexible connection to local gas detection units by either Analog or RS485 fieldbus communications
- Located in Controller Solution or in the field
- Easy configuration via intuitive user-interface; helps simplify operator handling and minimize risk of operational setting errors
- Simple commissioning by standard parameter configuration
- Enables regulatory compliance with EN 378:2016, ISO 5149:2014,

Product specification

Electrical

Table 1: Electrical

Power supply	24 V DC \pm 20 %
Power consumption	3 W, 120 mA
Analog input (4)	4 – 20 mA, overload and short-circuit protected, input resistance 200 Ω
Tension for external analog transmitter	24 V DC (same as power supply), max. 100 mA / per sensor
Analog output (2) configurable for each input	Proportional, overload and short-circuit- protected, charge \leq 500 Ω 4 – 20 mA = measuring range 3.0 < 4 mA = underrange >20 – 21.2 mA = overrange 2.0 mA = fault
Alarm relay (4)	250 V AC, 5 A, potential-free, change-over (SPDT)

Interface fieldbus

Table 2: Interface fieldbus

Transceiver	RS 485 / 19200 Baud
--------------------	---------------------

Environmental

Table 3: Environmental

Humidity	15 – 95 % RH non-condensing
Working temperature	-10 °C to +40 °C (14 °F to 104 °F)
Storage temperature	0 °C – +40 °C (32 °F to 104 °F)

Physical

Table 4: Physical

Enclosure	Plastic housing ABS
Colour	Black
Protection class	IP40
Weight	0.2 kg (0.5 lb.)
Packaging volumes	Ca. 4.4 l
Mounting	Top hat DIN rail mounting
Dimensions	(W x H x D) 104 x 86 x 56 mm (4.1 x 3.4 x 2.2 in.)
Wire connection:	
Power supply	Screw type terminal: 2.5 mm ² (14 AWG)
Output	2 x spring type terminal: min. 0.5 mm ² , max. 1.5 mm ² (22 to 16 AWG)
Input	Spring type: min. 0.5 mm ² , max. 1.5 mm ² (22 to 16 AWG)

Options - control of external warning devices

Table 5: Options - control of external warning devices

Power supply of the external warning devices	24 V DC
Measuring resistance at the warning device	12 k Ω , 0.5 W, 5 %

i NOTE:

If expansion modules are distributed along the communication bus it is recommended that each be powered by a separate DC power supply with only the ground connected to the bus.

Installation

Figure 1: Expansion modules installation in Controller Solution. Resistor R (560 Ohm)

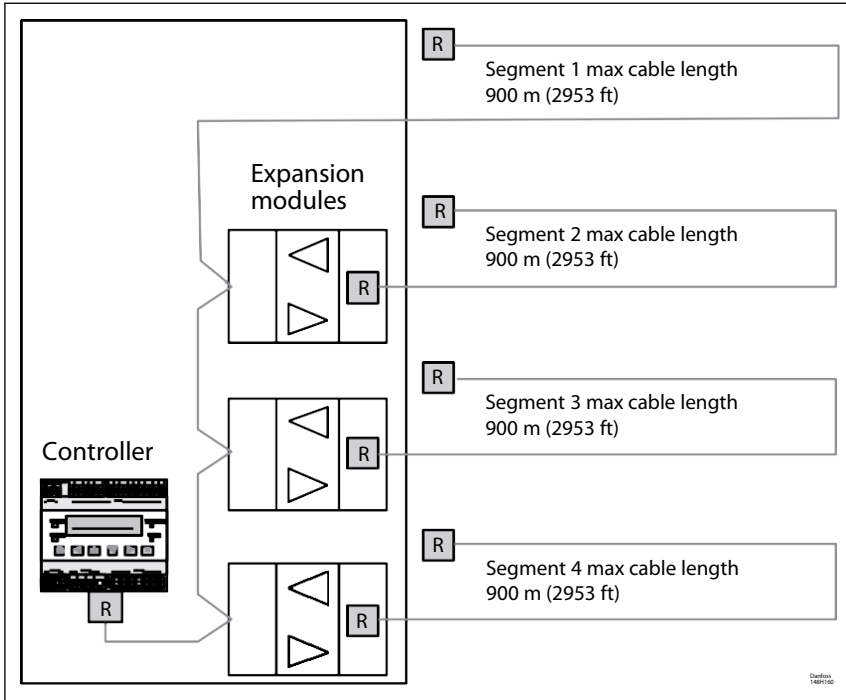

Expansion modules are installed close to the Controller (Controller Solution) or in the field (Examples shown above).

Each cable end must be applied a Resistor of 560 Ohm.

Figure 2: Expansion modules installation in the field. Resistor R (560 Ohm)

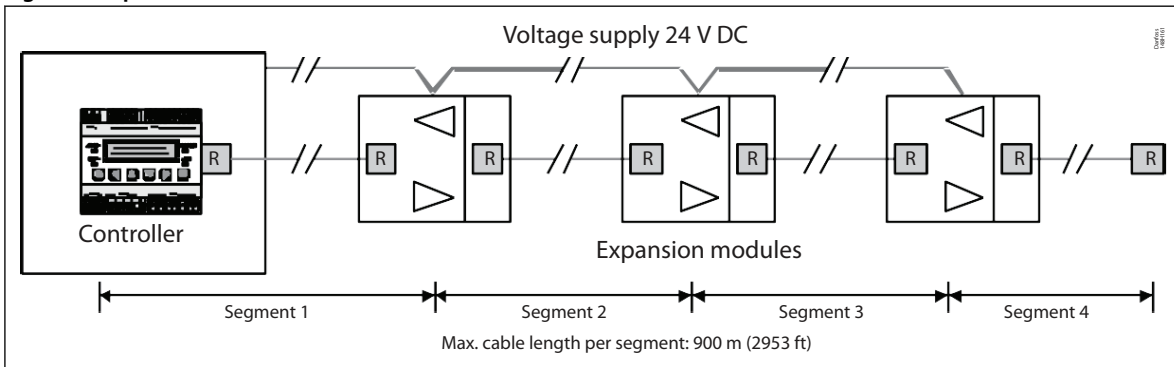
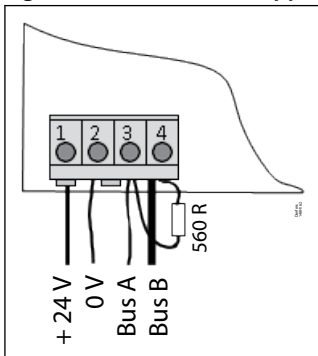
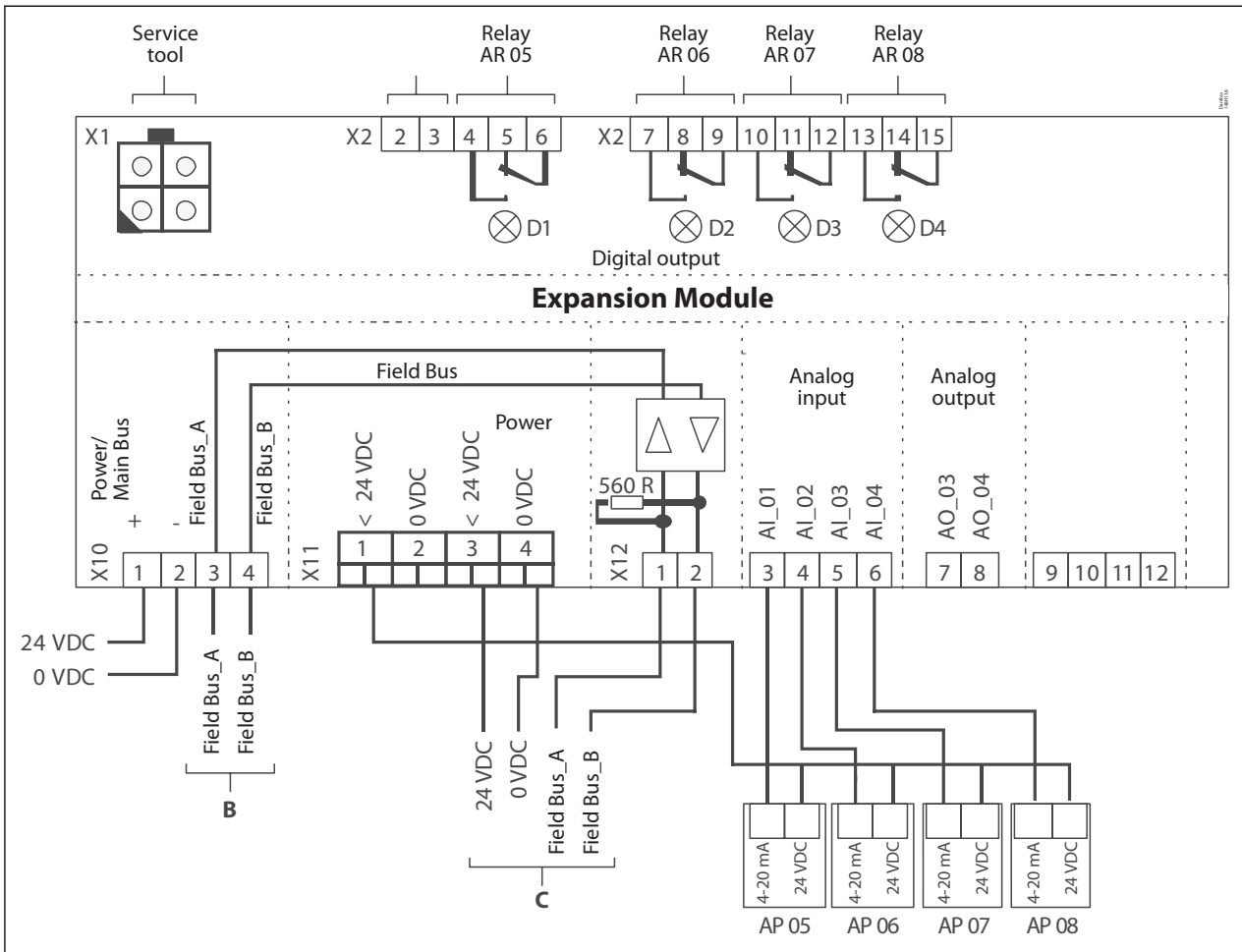

Figure 3: Each Cable end applied 560 Ohm



Wiring configuration



Ordering

Table 6: Ordering

Description	Code number
Expansion module	148H6222

Certificates, declarations, and approvals

The list contains all certificates, declarations, and approvals for this product type. Individual code number may have some or all of these approvals, and certain local approvals may not appear on the list.

Some approvals may change over time. You can check the most current status at danfoss.com or contact your local Danfoss representative if you have any questions.

Table 7: Compliance

EMC Directive 2014/30/EU
Low voltage directive 2014/35/EU
Conformity to: EN 50 545-1, EN 50271, EN 61010-1:2010, ANSI/UL 61010-1, CAN/CSA-C22.2 No. 61010-1

Online support

Danfoss offers a wide range of support along with our products, including digital product information, software, mobile apps, and expert guidance. See the possibilities below.

The Danfoss Product Store



The Danfoss Product Store is your one-stop shop for everything product related—no matter where you are in the world or what area of the cooling industry you work in. Get quick access to essential information like product specs, code numbers, technical documentation, certifications, accessories, and more.

Start browsing at store.danfoss.com.

Find technical documentation



Find the technical documentation you need to get your project up and running. Get direct access to our official collection of data sheets, certificates and declarations, manuals and guides, 3D models and drawings, case stories, brochures, and much more.

Start searching now at www.danfoss.com/en/service-and-support/documentation.

Danfoss Learning



Danfoss Learning is a free online learning platform. It features courses and materials specifically designed to help engineers, installers, service technicians, and wholesalers better understand the products, applications, industry topics, and trends that will help you do your job better.

Create your Danfoss Learning account for free at www.danfoss.com/en/service-and-support/learning.

Get local information and support



Local Danfoss websites are the main sources for help and information about our company and products. Find product availability, get the latest regional news, or connect with a nearby expert—all in your own language.

Find your local Danfoss website here: www.danfoss.com/en/choose-region.

Spare Parts



Get access to the Danfoss spare parts and service kit catalog right from your smartphone. The app contains a wide range of components for air conditioning and refrigeration applications, such as valves, strainers, pressure switches, and sensors.

Download the Spare Parts app for free at www.danfoss.com/en/service-and-support/downloads.