

Data Sheet

Solenoid valve
Type **EV260B**

Proportional servo operated for water, brine and oil regulation



EV260B is a proportional (modulating) servo-operated 2-way solenoid valve with connections from 1/4" to 3/4". Through stepless regulation of the coil current, the armature can be placed in any position in the armature tube, thus setting the valve to any position between fully closed and fully open. The valve is fully open when the coil current has reached its maximum value.

Features and versions

- For water, oil and similar neutral liquids
- Linear characteristic throughout the regulation range
- Closes on power failure (fail-safe function)
- Clip on coil
- Ambient temperature: Up to 50 °C
- Coil enclosure: Up to IP67
- Standard 4 – 20 mA or 0 – 10 V DC pilot signal

1 Portfolio overview

Table 1: Portfolio overview

Features	EV260B
	
Body material	Brass
DN [mm]	6-20
DN [inch]	1/4-3/4
Connection G	G3/8" - G1"
Connection NPT	NPT 1/4-3/4
Sealing material	PTFE
Function	NC
K_v [m³/h]	0.8-5
C_v [Gal/min]	0.9-5.8
Differential pressure range [bar]	0.5-10
Differential pressure range [psi]	7-156
Temperature range [°C]	-10-80
Temperature range [°F]	14-176

2 Functions

Proportional regulation of the opening and closing of the EV260B valves is achieved through stepless regulation of the coil current and thus of the pulling force of the solenoid coil.

PWM (Pulse width Regulation) is recommended, to have the best regulation and avoid hysteresis.

When the coil current is increased, the pulling force of the coil (1) will at a certain point exceed the counteracting spring force of the closing spring (2). The armature (3) moves up, opening the pilot orifice (4) in the diaphragm (5), which due to the servo effect follows the armature's movement.

The valve is fully open when the coil current has reached its maximum value.

Through stepless regulation of the coil current the armature can be placed in any position in the armature tube, and the valve thus set to any position between closed and open.

The effective coil current range for EV260B proportional valves without signal converter is approx. 300 – 600 mA.

The EV260B valves are also available with a signal converter built in the coil's terminal box (6). The signal converter's output terminals are connected to the solenoid coil.

The signal converter regulates the coil current so that it is proportional to the input signal (pilot signal).

- The pilot signal may be a
 - 0 – 10 V DC voltage signal or a
 - 4 – 20 mA current signal

NOTE:

The EV260B is not optimal as shut of valve at low differential pressures and when PTFE seal can be damaged by small particles.

Figure 1: Function NC

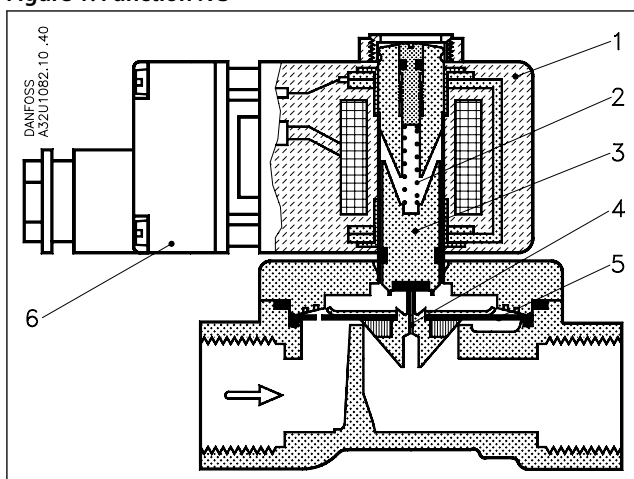

1.	Coil
2.	Closing spring
3.	Closing spring
4.	Pilot orifice
5.	Diaphragm
6.	Terminal box

3 Applications

It is recommended to use a filter in front of the valve. Recommended filter 50 mesh (297 microns).

Figure 2: Filter

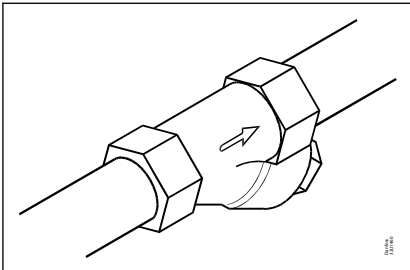

In water applications, exercise the valves at least once every 24 hours, meaning change the state of the valve. The valve exercise will minimize the risk of the valve sticking due to calcium carbonate, zinc or iron oxide build-up.

Figure 3: Exercise: Valve on/off

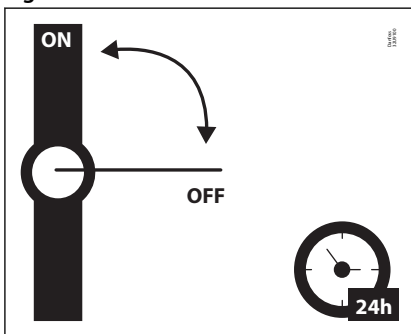

To minimize scaling, and corrosion attack it is recommended that the water passing the valve have the following values:

- Hardness 6-18 °dH to avoid scaling (chalk / lime stone build up).
- Conductivity 50 – 800 $\mu\text{S}/\text{cm}$ to avoid brass dezincification and corrosion.
- Above 25°C media temperature avoid stagnant water inside the valve to avoid dezincification and corrosion attack.

4 Product specification

4.1 Technical data

Table 2: Technical data

Media	PTFE	For water, oil, compressed air and similar neutral media
Media temperature [°C] [°F]	PTFE	-10-80°C / 14-176°F
Ambient temperature [°C] [°F]	Up to 55°C / 122°F	
K_v value [m³/h]	DN6	0.8 m³/h
	DN10	1.3 m³/h
	DN15	2.1 m³/h
	DN20	5 m³/h
C_v value [US gal/min]	1/4 inch	0.9 US gal/min
	3/8 inch	1.5 US gal/min
	9/16 inch	2.4 US gal/min
	3/4 inch	5.8 US gal/min
Min. Opening differential pressure [bar] [psi]	0.5 bar / 7 psi	
Max. Opening differential pressure [bar] [psi]	10 bar / 145 psi	
Max. working pressure [bar] [psi]	10 bar / 145 psi	
Max. test pressure [bar] [psi]	15 bar / 217 psi	
Viscosity [cSt]	Max. 50 cSt	
Rangeability and selection (DN6-DN20)	Since a proportional regulation valve it is recommended that operation differential pressure is higher than 1 bar and that average (middle) flow by size (DN 6, 10, 15, 20) is selected to be about 50% of full flow at given differential pressure. This will give the best regulation. Regulation in the range 0 – 5% of full flow may shorten the life time or create noise.	

Capacity diagram

Example: Capacity for EV260B 6 at differential pressure of 3 bar: Approx. 1.4 m³/h

Figure 4: Capacity diagram

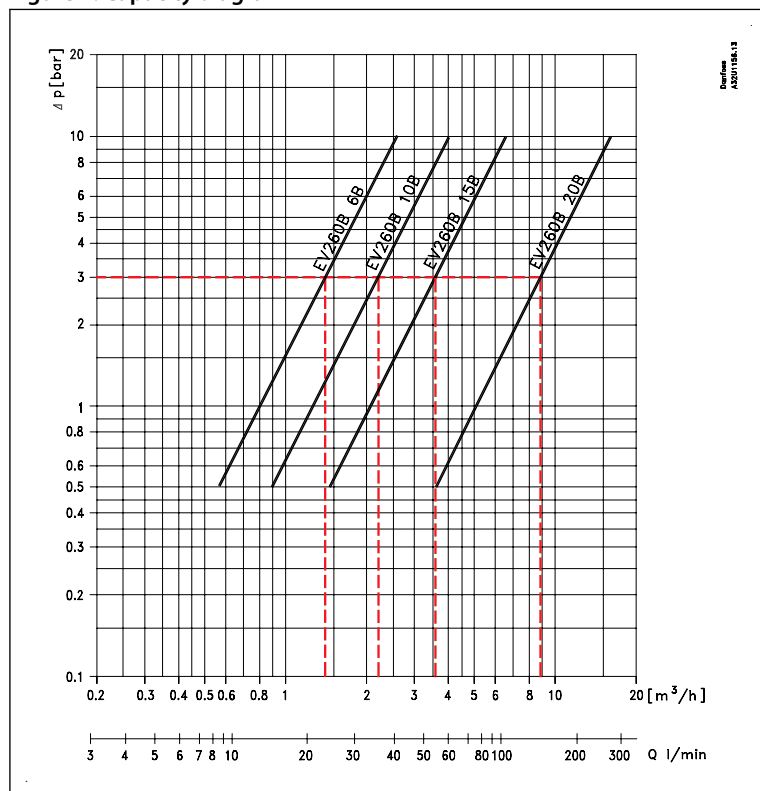

Signal flow characteristics

Figure 5: Coil type BK without signal converter

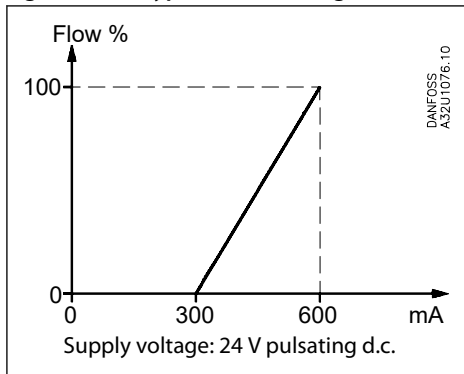

Coil type BK without signal converter

The basic version consists of a valve with a coil for pulsating direct current. The supply voltage of 24 V DC can be established with full-wave rectified alternating current. The valve begins to open at a coil current of approx. 300 mA and is fully open at a coil current of approx. 600 mA. The ratio between coil current and flow between the two outer points is directly proportional.

Figure 6: Coil type BM with signal converter and 0 – 10 V pilot signal

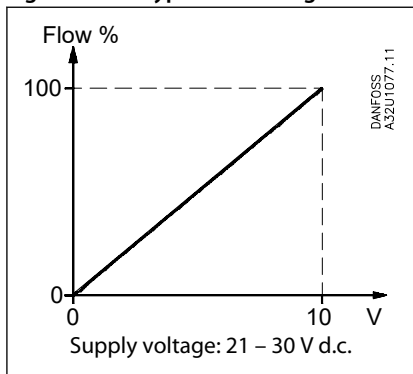

Coil type BM with signal converter and 0 – 10 V pilot signal

The ratio between pilot signal and flow is directly proportional throughout the regulation range.

Figure 7: Coil type BL with signal converter and 4 – 20 mA pilot signal

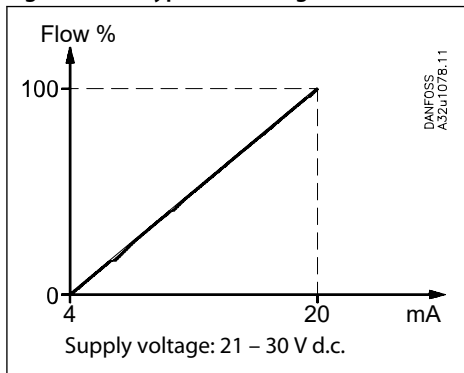

Coil type BL with signal converter and 4 – 20 mA pilot signal

The ratio between pilot signal and flow is directly proportional throughout the regulation range.

Materials

Table 3: Materials

Components	Materials	Specifications
Valve body	Brass	W.no. 2.0402
Armature	Stainless steel	W. no. 1.4105 / AISI 430FR
Armature tube	Stainless steel	W. no. 1.4306 / AISI 304L
Spindle	Stainless steel	W.no. 1.4105/AISI 430FR
Spring	Stainless steel	W.no. 1.4568
O-rings	NBR/ CR	
Valve plate	FKM	
Diaphragm	PTFE	
Seat and guide ring	PTFE	

4.2 Dimensions and weights

Table 4: Dimensions and weight

Type	Weight gross valve body without signal converter	Weight gross valve body with signal converter	L	L ₁ with terminal box	L ₁ with signal converter	L ₂	H ₁	H ₂	B
	[kg]								
EV260B 6	1.02	1.22	62	112	128	30	13	71	68
EV260B 10	1.02	1.22	62	112	128	30	13	71	68
EV260B 15	1.17	1.37	81	112	128	30	13	71	68
EV260B 20	1.71	1.91	98	112	128	30	13	71	68

Figure 8: Dimensions

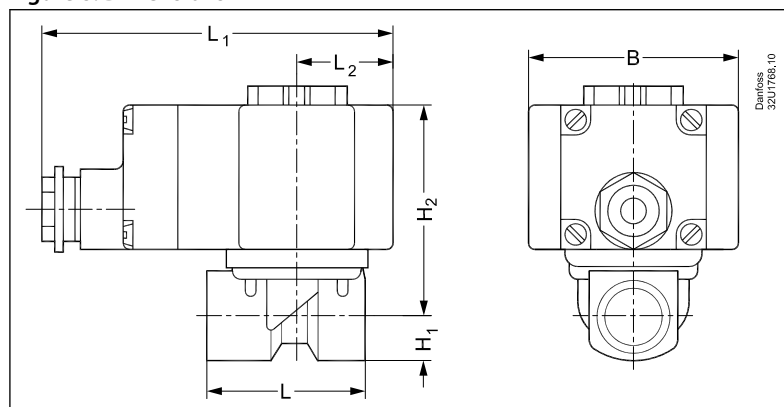

4.3 Mounting

Figure 9: Mounting angle

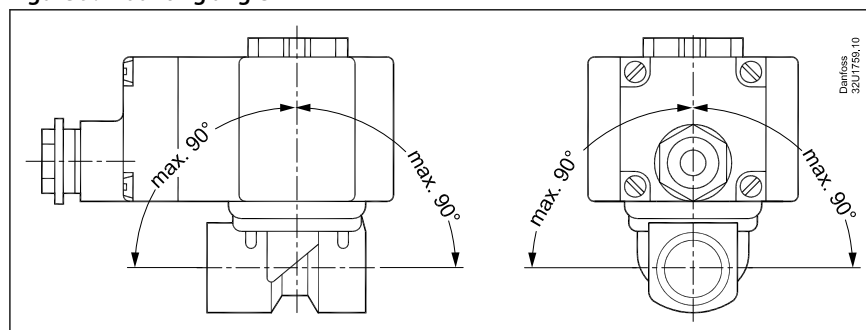

5 Ordering

5.1 Parts program

Table 5: Brass, valve body NC with G thread

ISO228/1 connection	Orifice	K _v value	Function
	[mm]	[m ³ /h]	NC
G1/4	6	0.8	032U8052
G3/8	6	0.8	032U8053
G3/8	10	1.3	032U8054
G1/2	10	1.3	032U8055
G1/2	15	2.1	032U8056
G3/4	20	5	032U8057

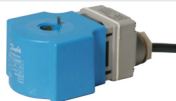

Table 6: Brass, valve body NC with NPT thread

ISO228/1 connection	Orifice	K _v value	Function
	[inch]	[US Gal/min]	NC
NPT 1/4	1/4	0.9	032U8062
NPT 3/8	1/4	0.9	032U8063
NPT 1/2	9/16	2.4	032U8066
NPT 3/4	3/4	5.8	032U8067

5.2 Accessories

Coil

Table 7: Below coils can be used with EV260B

Coil	Power consumption	Supply voltage	Enclosure	Features	Code no.
	20 W DC	24 V full wave rectified	"IP67 only including seal kit 018Z0090"	Terminal box	018Z6987
	20 W DC	21 – 30 V	"IP65 only including seal kit 018Z0090"	"With signal converter Pilot signal: 0 – 10 V 2 metre cable"	018Z0290
	20 W DC	21 – 30 V	"IP65 only including seal kit 018Z0090"	"With signal converter Pilot signal: 4 – 20 mA 2 metre cable"	018Z0291

Cable plug

Figure 10: Cable plug



Table 8: Cable plug

Type, Form A	Code no.
GDM 2011 (grey) cable plug according to DIN 43650-A PG11	042N0156

Universal electronic multi-timer, Type ET 20 M

Figure 11: Type ET 20 M



Table 9: Type ET 20 M

Type	Voltage	Suitable for coil types	Code no.
	[V]		
BA024A	24 - 240	AL, AM, AS, AZ, BA, BD, BB	042N0185

Spare parts kit

Table 10: Spare parts kit

Type EV260B 6-20	Spare part kit
	Sealing
	PTFE
EV260B 6	032U8039
EV260B 10	032U8040
EV260B 15	032U8041
EV260B 20	032U8042
	<ol style="list-style-type: none"> 1. Locking button 2. Locking nut 3. Adjustment screw including o-ring 4. Complete armature with spring 5. O-ring 6. Diaphragm 7. O-ring

6 Online support

Danfoss offers a wide range of support along with our products, including digital product information, software, mobile apps, and expert guidance. See the possibilities below.

The Danfoss Product Store



The Danfoss Product Store is your one-stop shop for everything product related—no matter where you are in the world or what area of the cooling industry you work in. Get quick access to essential information like product specs, code numbers, technical documentation, certifications, accessories, and more.

Start browsing at store.danfoss.com.

Find technical documentation



Find the technical documentation you need to get your project up and running. Get direct access to our official collection of data sheets, certificates and declarations, manuals and guides, 3D models and drawings, case stories, brochures, and much more.

Start searching now at www.danfoss.com/en/service-and-support/documentation.

Danfoss Learning



Danfoss Learning is a free online learning platform. It features courses and materials specifically designed to help engineers, installers, service technicians, and wholesalers better understand the products, applications, industry topics, and trends that will help you do your job better.

Create your Danfoss Learning account for free at www.danfoss.com/en/service-and-support/learning.

Get local information and support



Local Danfoss websites are the main sources for help and information about our company and products. Find product availability, get the latest regional news, or connect with a nearby expert—all in your own language.

Find your local Danfoss website here: www.danfoss.com/en/choose-region.

Spare Parts



Get access to the Danfoss spare parts and service kit catalog right from your smartphone. The app contains a wide range of components for air conditioning and refrigeration applications, such as valves, strainers, pressure switches, and sensors.

Download the Spare Parts app for free at www.danfoss.com/en/service-and-support/downloads.