

Installation guide

Piston kit \varnothing 35.1 (N)

VDHT 3/4 / 1 / ED (N) / EA (N) / BL (N) / BL (M)

180R9433

Indholdet i stempel reservedelssæt:
The Piston Spare Parts Kit consists of:
Der Ventilkolben Ersatzteilbausatz besteht aus:
Le kit de pièces de rechange pour piston comprend:

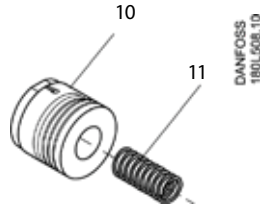

- Et komplet stempel "10"
- En fjeder "11"
- Complete piston "10" and
- Spring "11".
- Kolben "10", komplett und
- Feder "11".
- Piston complet "10" et
- Ressort "11".

180R9433

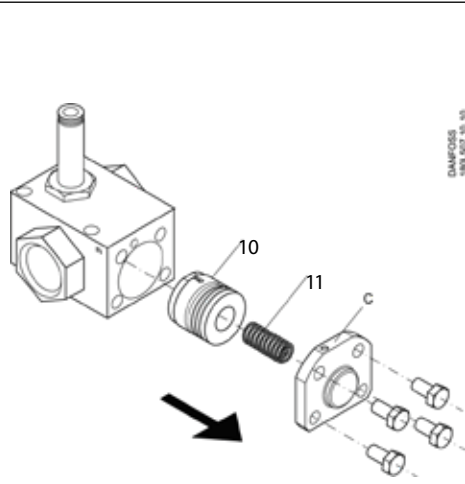

1. Udtagning af stempel

- a) Skru dæksel "C" af med en 13 mm 6-kant nøgle eller 6 mm unbrako nøgle
- b) Udtag fjeder "11"
- c) Udtag stempel "10" (sæt en finger i midten af stemplet og træk det ud).

1. Extracting piston

- a) Screw out the plug "C" with an 13 mm hexagon key or 6 mm allen key
- b) Take out spring "11"
- c) Take out piston "10" (place a finger into the center of the piston and pull it out).

1. Ventilkolben Ausbauen

- a) Pfropfen "C" mittels Sechskantschlüssels 13 mm abschrauben oder Inbusschlüssel 6 mm
- b) Feder "11" entnehmen
- c) Kolben "10" entnehmen (ein Finger im Mitten des Kolbens setzen und Kolben ausziehen).

1. Retirer le piston

- a) Dévisser le bouchon «C» avec une clé hexagonale de 13 mm ou une clé Allen de 6 mm.
- b) Retirer le ressort "11"
- c) Retirer le piston "10" (placer un doigt derrière le piston et le tirer).

2. Indføring af stempel

- a) Nyt stempel "10" skubbes ind i ventilen
 - b) Ny fjeder "11" placeres bag stemplet
 - c) Monter dæksel "C" så fjederen passer ind i fordybningen i dækslet.
 - d) Skru de 4 skruer i dækslet (moment 30 Nm)
- Hvis mod forventning at den lille O-ring i dækslet "C" falder ud ved afmonteringen af dækslet, skal O-ringen genplaceres i dækslet inden det påmonteres igen.

2. Insertion of piston

- a) Push new piston "10" into the valve
 - b) Place new spring "11" behind the piston
 - c) Mount cover "C" to make the spring fit into the groove in the cover.
 - d) Screw the 4 screws into the cover (torque 30 Nm)
- If – contrary to expectation – the O-ring in the cover "C" falls out during demounting of the cover, the O-ring must be replaced in the cover before remounting.

2. Einführung des Kolbens

- a) Neuer Kolben "10" in das Ventil hineinschieben
 - b) Neue Feder "11" hinter dem Kolben plazieren
 - c) Deckel "C" so anbringen, damit die Feder in der Vertiefung im Deckel passt
 - d) Die 4 Schrauben in den Deckel einschrauben (Moment 30 Nm)
- Falls – wider Erwarten – der O-Ring im Deckel "C" während der Demontage herausfällt, muss der O-Ring wieder im Deckel vor Neumontage plaziert werden.

2. Insertion du piston

- a) Pousser le nouveau piston "10" dans la vanne
 - b) Placer le nouveau ressort "11" à l'arrière du piston
 - c) Monter le couvercle "C" afin d'ajuster le ressort dans la rainure du couvercle
 - d) Introduire et serrer les 4 vis dans le couvercle (couple 30 Nm)
- Si, contre toute attente, le joint (O-ring) placé dans le couvercle devait tomber lors du démontage, il sera remis en place avant de remonter l'ensemble.

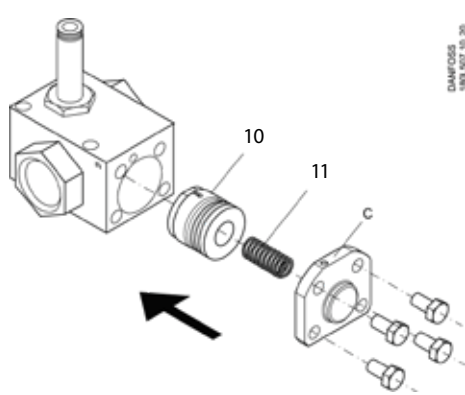

Danfoss A/S

High Pressure Pumps • danfoss.com • +45 7488 2222 • E-mail: highpressurepumps@danfoss.com

Any information, including, but not limited to information on selection of product, its application or use, product design, weight, dimensions, capacity or any other technical data in product manuals, catalogues descriptions, advertisements, etc. and whether made available in writing, orally, electronically, online or via download, shall be considered informative, and is only binding if and to the extent, explicit reference is made in a quotation or order confirmation. Danfoss cannot accept any responsibility for possible errors in catalogues, brochures, videos and other material. Danfoss reserves the right to alter its products without notice. This also applies to products ordered but not delivered provided that such alterations can be made without changes to form, fit or function of the product. All trademarks in this material are property of Danfoss A/S or Danfoss group companies. Danfoss and the Danfoss logo are trademarks of Danfoss A/S. All rights reserved.