

Data Sheet

Filter drier, shell Types **DCR** and **DCRE**

Danfoss **ELIMINATOR**® filter drier **with replaceable solid core**.
Designed for applications requiring high moisture capacity and acid adsorption capacity.



Danfoss ELIMINATOR® filter driers with replaceable solid core, type DCR, are for use in liquid and / or suction lines in refrigeration, freezing and air-conditioning systems.

Besides being able to meet the demanding requirements of high working pressure levels when operating with R410A thanks to replaceable solid cores the DCR programme offers flexibility with respect to different applications.

Available with copper connections. DCRE programme offers to be used with flammable refrigerants A2L, Group .

Features

DCR / DCRE housing:

- PED approved for PS up to 46 bar for the DCR and up to 50 bar for DCRE
- DCR / DCRE housing (including core holder) are made entirely of steel and are thus compatible with all refrigerants
- DCR / DCRE housings have undergone phosphate pre-treatment and have a corrosion-resistant powder-paint finish
- DCR / DCRE housings are helium leak tested

Top covers for DCR / DCRE housings:

- Zinc-chromated steel top covers with or without external access connection

Inserts for DCR housings - strainer 48 - F strainer - compatible with all refrigerants:

- Retains dirt particles larger than 15 µm
- For use direct in DCR housings
- Utilised in the suction or liquid line

Inserts for DCR housings - solid cores

48 - DM - 100% molecular sieve solid core suitable for HFC refrigerants:

- Provides high moisture adsorption at low and high condensing temperatures
- Effective protection against impurities

48 - DC - 80% molecular sieve and 20% activated alumina solid core suitable for HCFC refrigerants and compatible with HFC refrigerants:

- Adsorbs moisture and acid in the system throughout the entire temperature range

48 - DA - 30% molecular sieve and 70% activated alumina solid core suitable after compressor burnout and compatible with HCFC / HFC refrigerants:

Inserts for DCRE housings - solid cores:

- 48 - DM
- 48 - DC

All solid cores have an optimised uniform grain size ensuring effective dirt removal and low pressure drop. The robust solid cores withstand pressure surge and vibration.

Functions

Figure 1: DCR

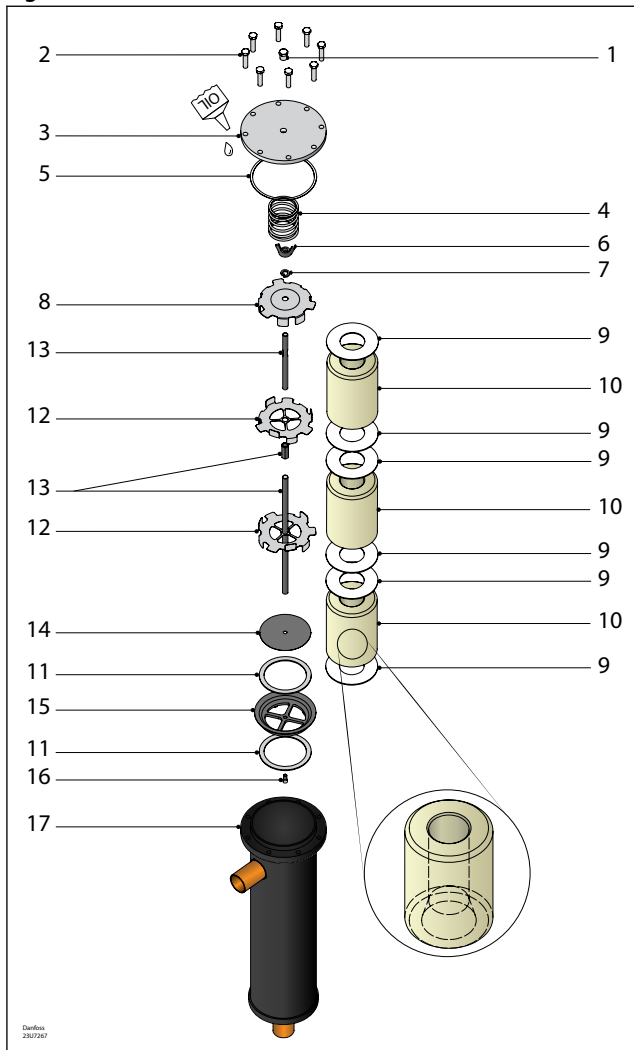
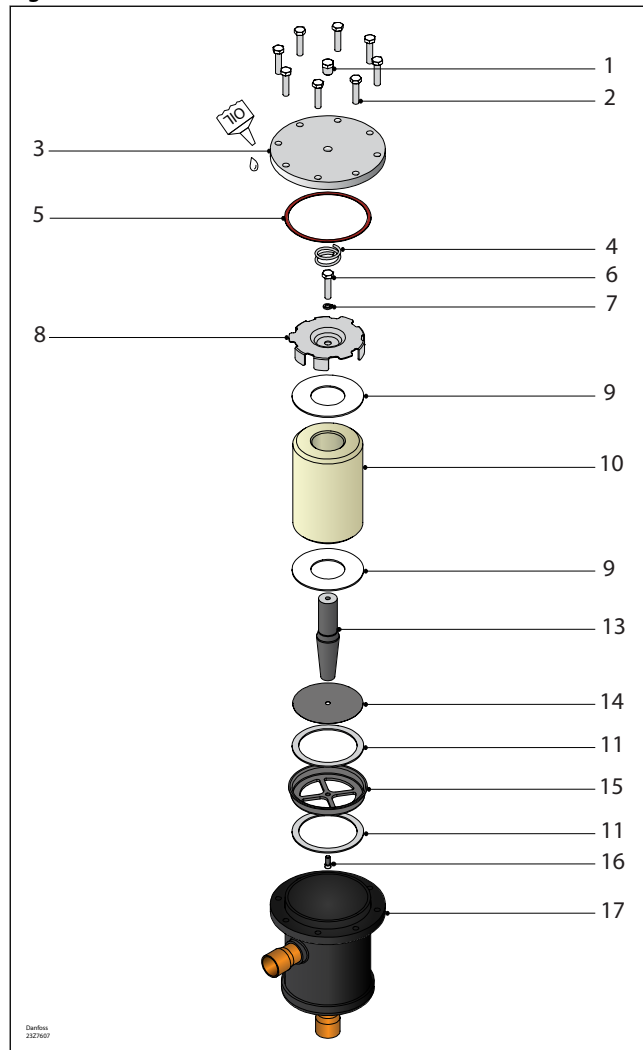

Figure 2: DCRE



1	Plug for cover	10	Solid core
2	Bolts for cover	11	Core holder felt gasket
3	Top cover	12	Core plate
4	Spring	13	Distance rod
5	Top cover gasket	14	Wire mesh
6	Wing nut (DCR) / Bolt (DCRE)	15	Core holder
7	Lock washer	16	Hex socket head screw
8	Top plate	17	Shell
9	Core felt gasket		

Inner taper of core should always face towards filter outlet. This apply for DCR and DCRE components.

NOTE:

The DCRE can only be use for A2L when the solid core is placed. DCRE is not allowed to be used as receiver.

Applications

Danfoss ELIMINATOR® filter driers with replaceable solid core, type DCR / DCRE, protect refrigeration, freezing and air-conditioning systems from moisture, acids, and solid particles.

With these contaminants eliminated, systems are safer from harmful chemical reactions and from abrasive impurities.

Figure 3: Applications

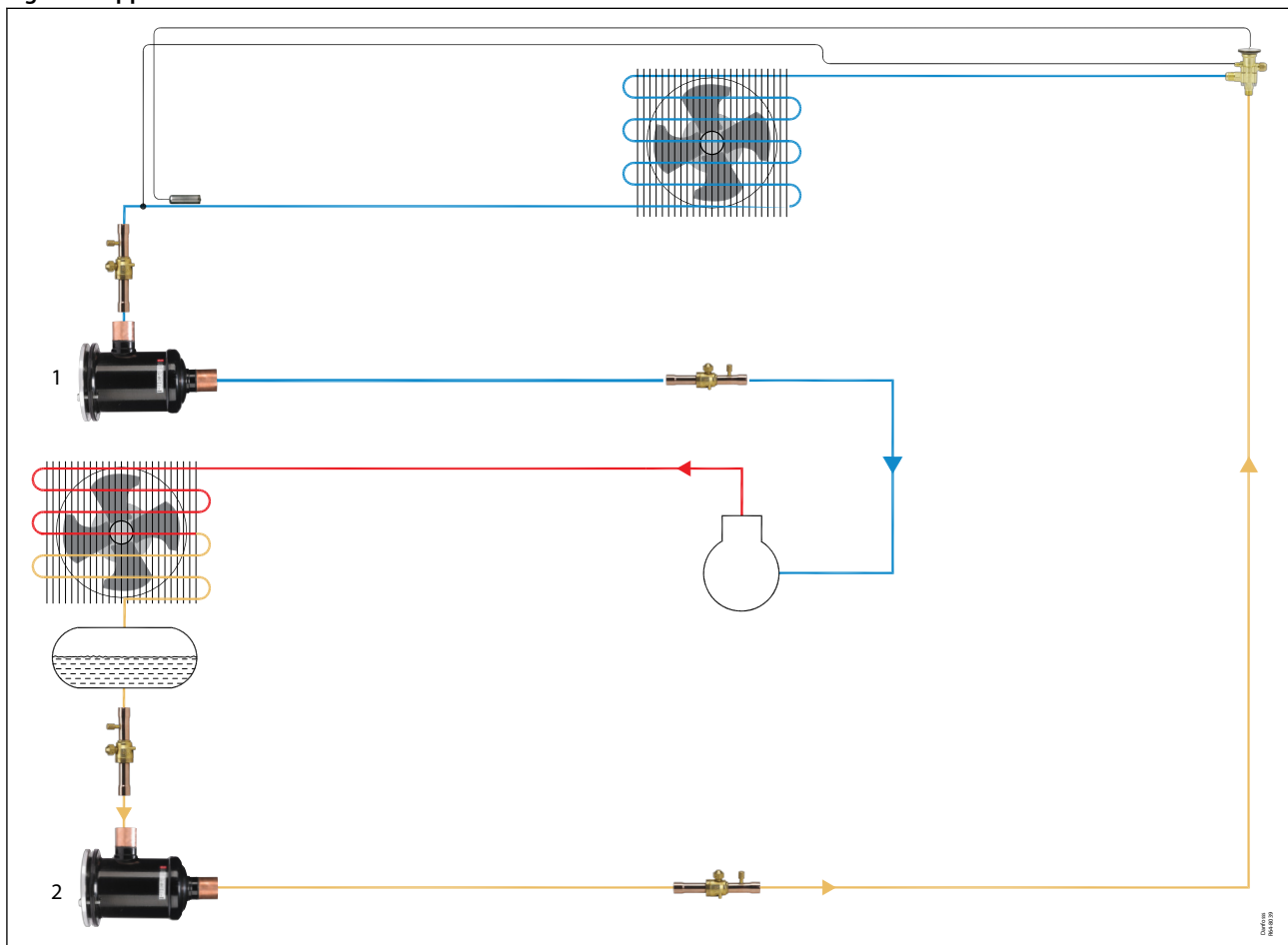

- | | |
|---|--------------------------------------|
| 1 | DCR, suction line filter drier |
| 2 | DCR / DCRE, liquid line filter drier |

Product specification

Technical data

Table 1: Technical data

Type	Maximum working pressure PS	Temperature range
	[bar]	
DCR 048	46	- 40 – 70 °C
DCR 096	46	- 40 – 70 °C
DCR 144	35 ⁽¹⁾ / 46 ⁽²⁾	- 40 – 70 °C
DCR 192	28 ⁽¹⁾ / 40 ⁽²⁾	- 40 – 70 °C
DCRE 048	50	- 40 – 70 °C

⁽¹⁾ For usage with strainer or as a receiver application

⁽²⁾ For “drier” application using all the permissible cores

Connections

Table 2: Type of connector

Connector	Connector type
	Copper ODF solder connector Copper pipe
	Steel ODF solder connector Copper pipe
	Steel butt weld connector Steel pipe

Table 3: Type of connector and recommended soldering material

Solder connector	Recommended soldering material
Copper	Min. 5% Ag
Steel	Silver-flo 55 + Easy-flow flux

Identification

Table 4: Type codes

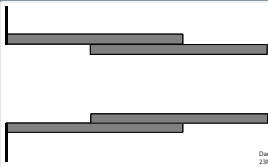
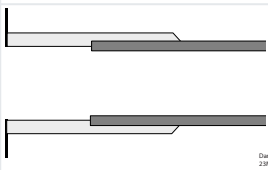
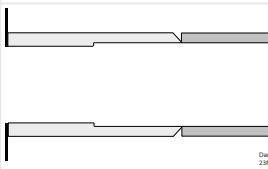
Type	Code	Description
Filter drier	D	Drier
	C	Solid core
	R	Replaceable
Solid core	E	Flammable refrigerants
	048	48 in ³
	096	96 in ³
Size (volume)	144	144 in ³
	192	192 in ³

Filter drier, shell, types DCR and DCRE

Type	Code	Description
Connection (filter connection in 1/8 of an inch increments)	5	5/8 in. / 16 mm
	7	7/8 in. / 22 mm
	9	1 1/8 in. / 28 mm
	11	1 3/8 in. / 35 mm
	13	1 5/8 in. / 42 mm
	17	2 1/8 in. / 54 mm
	21	2 5/8 in.
Connection type	(blank)	Steel connectors
	s	Copper connectors

Capacity

Table 5: DCR Drying and liquid capacity, type 48-DM

Type	No. of cores	Drying capacity [kg refrigerant] ⁽¹⁾										Liquid capacity [kW] ⁽²⁾					Max. working pressure PS [bar]
		R134a		R404A		R507		R407C		R410A		R134a	R404A	R507	R407C	R410A	
		[°C]															
		24	52	24	52	24	52	24	52	24	52						
DCR 0485	1	83.4	76.4	86.9	82.3	91.0	81.9	81.0	74.7	75.5	67.2	67.0	47.1	45.7	68.7	69.7	46
DCR 0487	1	83.4	76.4	86.9	82.3	91.0	81.9	81.0	74.7	75.5	67.2	127.0	89.3	86.6	130.1	132.1	46
DCR 0489	1	83.4	76.4	86.9	82.3	91.0	81.9	81.0	74.7	75.5	67.2	165.0	116.0	112.6	169.1	171.7	46
DCR 04811	1	83.4	76.4	88.7	82.3	91.0	81.9	81.0	74.7	75.5	67.2	205.0	144.2	139.8	210.1	213.3	46
DCR 04813	1	83.4	76.4	86.9	82.3	91.0	81.9	81.0	74.7	75.5	67.2	230.3	162.0	157.1	236.0	239.6	46
DCR 04817	1	83.4	76.4	86.9	82.3	91.0	81.9	81.0	74.7	75.5	67.2	250.1	175.9	170.6	256.3	260.2	46
DCR 04821	1	83.4	76.4	86.9	82.3	91.0	81.9	81.0	74.7	75.5	67.2	255.0	179.3	174.0	261.3	265.4	46
DCR 0967	2	166.8	152.8	173.8	164.6	182.0	163.8	162.0	149.4	151.0	134.4	134	94.3	91.4	137.4	139.5	46
DCR 0969	2	166.8	152.8	173.8	164.6	182.0	163.8	162.0	149.4	151.0	134.4	212.3	149.3	144.8	217.6	220.9	46
DCR 09611	2	166.8	152.8	173.8	164.6	182.0	163.8	162.0	149.4	151.0	134.4	216.9	152.6	148.0	222.3	225.7	46
DCR 09613	2	166.8	152.8	173.8	164.6	182.0	163.8	162.0	149.4	151.0	134.4	294.9	207.4	201.1	302.2	306.8	46
DCR 09617	2	166.8	152.8	173.8	164.6	182.0	163.8	162.0	149.4	151.0	134.4	358	251.8	244.2	366.9	372.5	46
DCR 1449	3	250.2	229.2	260.7	246.9	273.0	245.7	243.0	224.1	226.5	201.6	222.2	156.3	151.6	227.7	231.2	35 ⁽³⁾ / 46 ⁽⁴⁾
DCR 14411	3	250.2	229.2	260.7	246.9	273.0	245.7	243.0	224.1	226.5	201.6	225.7	158.8	154.0	231.3	234.9	35 ⁽³⁾ / 46 ⁽⁴⁾
DCR 14413	3	250.2	229.2	260.7	246.9	273.0	245.7	243.0	224.1	226.5	201.6	355.9	250.3	242.8	364.7	370.3	35 ⁽³⁾ / 46 ⁽⁴⁾
DCR 14417	3	250.2	229.2	260.7	246.9	273.0	245.7	243.0	224.1	226.5	201.6	355.9	250.3	242.8	364.7	370.3	35 ⁽³⁾ / 46 ⁽⁴⁾
DCR 19211	4	333.6	305.6	347.6	329.2	364.0	327.6	324.0	298.8	302.0	268.8	371.7	261.4	253.6	381	386.8	28 ⁽³⁾ / 40 ⁽⁴⁾
DCR 19213	4	333.6	305.6	347.6	329.2	364.0	327.6	324.0	298.8	302.0	268.8	459.9	323.5	313.7	471.4	478.6	28 ⁽³⁾ / 40 ⁽⁴⁾
DCR 19217	4	333.6	305.6	347.6	329.2	364.0	327.6	324.0	298.8	302.0	268.8	459.9	323.5	313.7	471.4	478.6	28 ⁽³⁾ / 40 ⁽⁴⁾
DCR 19221	4	333.6	305.6	347.6	329.2	364.0	327.6	324.0	298.8	302.0	268.8	459.9	323.5	313.7	471.4	478.6	28 ⁽³⁾ / 40 ⁽⁴⁾

⁽¹⁾ Drying capacity is based on following moisture content test standards before and after drying:

- R134a: 1050 – 50 ppm W
 - R404A, R507: 1020 – 50 ppm W
 - R407C: 1020 – 50 ppm W
 - R410A: 1050 – 50 ppm W
 - R22: 1050 – 60 ppm.
- In accordance with ARI 710-2004

⁽²⁾ Given in accordance with ARI 710-2004 for:

- $t_e = -15\text{ °C}$
- $t_c = 30\text{ °C}$
- $\Delta p = 0.07\text{ bar}$

⁽³⁾ For usage with strainer or as a receiver application

⁽⁴⁾ Refrigerants other than specified in the table please contact Danfoss for the approval.

Table 6: DCR Drying and liquid capacity , type 48-DC

Type	No. of cores	Drying capacity [kg refrigerant] ⁽¹⁾										Liquid capacity [kW] ⁽²⁾					Max. working pressure
		R134a		R404A		R507		R407C		R410A		R134a	R404A	R507	R407C	R410A	
		[°C]															PS
		24	52	24	52	24	52	24	52	24	52	24	52	[bar]			
DCR 0485	1	65.5	59.9	68.2	64.6	71.4	64.3	63.6	58.6	59.3	52.7	67.0	47.1	45.7	68.7	69.7	46
DCR 0487	1	65.5	59.9	68.2	64.6	71.4	64.3	63.6	58.6	59.3	52.7	127.0	89.3	86.6	130.1	132.1	46
DCR 0489	1	65.5	59.9	68.2	64.6	71.4	64.3	63.6	58.6	59.3	52.7	165.0	116.0	112.6	169.1	171.7	46
DCR 04811	1	65.5	59.9	68.2	64.6	71.4	64.3	63.6	58.6	59.3	52.7	205.0	144.2	139.8	210.1	213.3	46
DCR 04813	1	65.5	59.9	68.2	64.6	71.4	64.3	63.6	58.6	59.3	52.7	230.3	162.0	157.1	236.0	239.6	46
DCR 04817	1	65.5	59.9	68.2	64.6	71.4	64.3	63.6	58.6	59.3	52.7	250.1	175.9	170.6	256.3	260.2	46
DCR 04821	1	65.5	59.9	68.2	64.6	71.4	64.3	63.6	58.6	59.3	52.7	255.0	179.3	174.0	261.3	265.4	46
DCR 0967	2	131.0	119.8	136.4	129.2	142.8	128.6	126.6	117.2	118.6	105.4	134.0	94.3	91.4	137.4	139.5	46
DCR 0969	2	131.0	119.8	136.4	129.2	142.8	128.6	126.6	117.2	118.6	105.4	212.3	149.3	144.8	217.6	220.9	46
DCR 09611	2	131.0	119.8	136.4	129.2	142.8	128.6	126.6	117.2	118.6	105.4	216.9	152.6	148.0	222.3	225.7	46
DCR 09613	2	131.0	119.8	136.4	129.2	142.8	128.6	126.6	117.2	118.6	105.4	294.9	207.4	201.1	302.2	306.8	46
DCR 09617	2	131.0	119.8	136.4	129.2	142.8	128.6	126.6	117.2	118.6	105.4	358.0	251.8	244.2	366.9	372.5	46
DCR 1449	3	196.5	179.7	204.6	193.8	214.2	192.9	189.9	175.8	177.9	158.1	222.2	156.3	151.6	227.7	231.2	35 ⁽³⁾ / 46 ⁽⁴⁾
DCR 14411	3	196.5	179.7	204.6	193.8	214.2	192.9	189.9	175.8	177.9	158.1	225.7	158.8	154.0	231.3	234.9	35 ⁽³⁾ / 46 ⁽⁴⁾
DCR 14413	3	196.5	179.7	204.6	193.8	214.2	192.9	189.9	175.8	177.9	158.1	355.9	250.3	242.8	364.7	370.3	35 ⁽³⁾ / 46 ⁽⁴⁾
DCR 14417	3	196.5	179.7	204.6	193.8	214.2	192.9	189.9	175.8	177.9	158.1	355.9	250.3	242.8	364.7	370.3	35 ⁽³⁾ / 46 ⁽⁴⁾
DCR 19211	4	262.0	239.6	272.8	258.4	285.6	257.2	253.2	234.4	237.2	210.8	371.7	261.4	253.6	381.0	386.8	28 ⁽³⁾ / 40 ⁽⁴⁾
DCR 19213	4	262.0	239.6	272.8	258.4	285.6	257.2	253.2	234.4	237.2	210.8	459.9	323.5	313.7	471.4	478.6	28 ⁽³⁾ / 40 ⁽⁴⁾
DCR 19217	4	262.0	239.6	272.8	258.4	285.6	257.2	253.2	234.4	237.2	210.8	459.9	323.5	313.7	471.4	478.6	28 ⁽³⁾ / 40 ⁽⁴⁾
DCR 19221	4	262.0	239.6	272.8	258.4	285.6	257.2	253.2	234.4	237.2	210.8	459.9	323.5	313.7	471.4	478.6	28 ⁽³⁾ / 40 ⁽⁴⁾

⁽¹⁾ Drying capacity is based on following moisture content test standards before and after drying:

- R134a: 1050 – 50 ppm W
 - R404A, R507: 1020 – 50 ppm W
 - R407C: 1020 – 50 ppm W
 - R410A: 1050 – 50 ppm W
 - R22: 1050 – 60 ppm
- In accordance with ARI 710-2004

⁽²⁾ Given in accordance with ARI 710-2004 for:

- t_e = -15 °C
- t_c = 30 °C
- Δp = 0.07 bar

⁽³⁾ For usage with strainer or as a receiver application

⁽⁴⁾ Refrigerants other than specified in the table please contact Danfoss for the approval.

Table 7: Recommended plant capacity in suction line - burn-out, type 48-DA

Type	Recommended plant capacity [kW]											
	Evaporating temperature t _e [°C]											
	-40	-20	4.4	-30	-20	4.4	-40	-20	4.4	-40	-20	4.4
	Pressure drop Δp [bar]											
	0.04	0.1	0.21	0.04	0.07	0.14	0.04	0.1	0.21	0.04	0.1	0.21
R22 / R407C			R134a			R404A / R507			R410A			
DCR 0485	3.1	8.9	21	3	5.4	13	2.4	7.1	17.5	3.1	8.9	21
DCR 0487	5.8	16.1	37.8	5.6	9.9	23.4	4.5	12.9	31.2	5.8	16.1	37.8
DCR 0489	7.8	21.6	50.7	7.5	13.3	31.5	6	17.2	41.8	7.8	21.6	50.7
DCR 04811	10	27.3	63.3	9.6	16.8	39.5	7.7	21.8	51.9	10	27.3	63.3
DCR 04813	10	27.3	63.3	9.6	16.8	39.5	7.7	21.8	51.9	10	27.3	63.3
DCR 04817	10	27.3	63.3	9.6	16.8	39.5	7.7	21.8	51.9	10	27.3	63.3
DCR 04821	10	27.3	63.3	9.6	16.8	39.5	7.7	21.8	51.9	10	27.3	63.3
DCR 0965	3.3	9.1	21.4	3.2	5.7	13.4	2.5	7.4	18	3.3	9.2	21.6
DCR 0967	5.8	16.2	38.1	5.6	9.9	23.6	4.5	12.9	31.4	5.8	16.2	38.1
DCR 0969	8.7	24.6	58.3	8.4	15	35.9	6.8	19.7	48.1	8.7	24.6	58.3
DCR 09611	11.9	33.4	79.3	11.4	20.4	48.9	9.3	26.8	65.4	11.9	33.4	79.3
DCR 09613	14.1	39.9	95.2	13.6	24.3	58.5	11	32	78.7	14.1	39.9	95.2
DCR 09617	14.1	39.9	95.2	13.6	24.3	58.5	11	32	78.7	14.1	39.9	95.2

Filter drier, shell, types DCR and DCRE

Type	Recommended plant capacity [kW]											
	Evaporating temperature t_e [°C]											
	-40	-20	4.4	-30	-20	4.4	-40	-20	4.4	-40	-20	4.4
	Pressure drop Δp [bar]											
	0.04	0.1	0.21	0.04	0.07	0.14	0.04	0.1	0.21	0.04	0.1	0.21
R22 / R407C			R134a			R404A / R507			R410A			
DCR 09621	14.1	39.9	95.2	13.6	24.3	58.5	11	32	78.7	14.1	39.9	95.2
DCR 1445	3.5	10	22.8	3.4	6	14	2.7	7.7	18.9	3.5	10	22.8
DCR 1447	6.6	18.9	42.9	6.3	11.2	26.4	5.1	14.5	35.6	6.6	18.9	42.9
DCR 1449	8.8	25.1	57.2	8.4	15	35.2	6.8	19.4	47.5	8.8	25.1	57.2
DCR 14411	13.2	38.1	92.2	12.7	23	56.2	10.3	30.7	76.6	13.2	38.1	92.2
DCR 14413	13.2	38.1	92.2	12.7	23	56.2	10.3	30.7	76.6	13.2	38.1	92.2
DCR 14417	13.2	38.1	92.2	12.7	23	56.2	10.3	30.7	76.6	13.2	38.1	92.2
DCR 14421	13.2	38.1	92.2	12.7	23	56.2	10.3	30.7	76.6	13.2	38.1	92.2
DCR 1925	4.2	11.5	27.3	4	7.1	16.8	3.2	9.2	22.7	4.2	11.5	27.3
DCR 1927	7.9	21.6	51.4	7.6	13.4	31.6	6.1	17.4	42.7	7.9	21.6	51.4
DCR 1929	10.6	28.9	68.9	10.2	18	42.1	8.2	23.3	57.2	10.6	28.9	68.9
DCR 19211	14.8	41.8	99.4	14.3	25.5	61.2	11.6	33.6	82.2	14.8	41.8	99.4
DCR 19213	18	51.1	122.1	17.4	31.1	75	14.1	41.1	101	18	51.1	122.1
DCR 19217	18	51.1	122.1	17.4	31.1	75	14.1	41.1	101	18	51.1	122.1
DCR 19221	18	51.1	122.1	17.4	31.1	75	14.1	41.1	101	18	51.1	122.1

NOTE:

Data given in accordance with ARI-Standard 710-2004 for $t_e = 4.4$ °C and $t_c = 32.2$ °C

Table 8: DCR Drying and acid capacity , type 48-DA

Type	No. of cores	Drying capacity [g of water] ⁽¹⁾												Acid capacity ⁽²⁾ [g]
		Evaporating temperature t_e [°C]												
		-40	-20	4.4	-30	-20	4.4	-40	-20	4.4	-40	-20	4.4	
		R22 / R407C			R134a			R404A / R507			R410A			
DCR 048	1	28	19	12	45	38	27	47	30	19	42	35	25	26.6
DCR 096	2	56	37	24	90	77	54	94	60	37	84	70	50	53.3
DCR 144	3	84	56	36	135	115	81	142	90	56	126	105	75	79.9
DCR 192	4	112	74	48	180	153	108	189	120	75	168	140	100	106.5

⁽¹⁾ Drying capacity is expressed during drying in:

- R22: EPD = 10 ppm W, corresponding to a dew point temperature = -50 °C
- R134a: EPD = 50 ppm W, corresponding to a dew point temperature = -37 °C
- R404A: EPD = 10 ppm W, corresponding to a dew point temperature = -40 °C
- R407C: EPD = 10 ppm W, corresponding to a dew point temperature = -40 °C

⁽²⁾ Adsorption capacity of oleic acid at 0.05 TAN (Total Acid Number)

Figure 4: Strainer

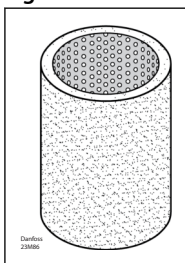

Table 9: Strainer mounted in suction line, type 48-F

Refrigerant	R22 / R407C			R134a			R404A / R507			R410A	
Evaporating temperature [°C]	-40	-20	4.4	-30	-20	4.4	-40	-20	4.4	-40	4.4
Pressure drop Δp [bar]	0.04	0.1	0.21	0.04	0.07	0.14	0.04	0.1	0.21	0.04	0.21
Recommended system capacity [kW]	15	47	113	15	28	69	12	38	93	15	113

Filter drier, shell, types DCR and DCRE

Table 10: Strainer mounted in liquid line

Refrigerant	R22 / R407C	R134a	R404A / R507	R410A
Recommended system capacity [kW] ⁽¹⁾	390	350	260	390

⁽¹⁾ The data given apply to DCR 04811 with 48-F core.

Liquid capacity is given in accordance with ARI 710-2004 for: $t_e = -15\text{ °C}$, $t_c = 30\text{ °C}$, $\Delta p = 0.07\text{ bar}$

Table 11: DCRE Drying and liquid capacity, type 48-DM

Type	No of cores	Drying capacity [kg refrigerant]										Liquid capacity [kW]					Max. working pressure p _S [bar]
		R32		R444B		R452B		R454B		R1234yf		R32	R444B	R452B	R454B	R1234yf	
		[°C]															
		24	52	24	52	24	52	24	52	24	52	24	52				
DCRE 0485s	1	70.2	64.6	83.0	74.3	80.4	71.6	82.6	76.5	155.9	143.9	102.1	77.9	85.1	69.0	48.5	50
DCRE 0487s	1	70.2	64.6	83.0	74.3	80.4	71.6	82.6	76.5	155.9	143.9	221.4	138.9	184.5	149.5	105.2	50
DCRE 0489s	1	70.2	64.6	83.0	74.3	80.4	71.6	82.6	76.5	155.9	143.9	245.9	154.3	204.9	166.0	116.9	50
DCRE 04811s	1	70.2	64.6	83.0	74.3	80.4	71.6	82.6	76.5	155.9	143.9	312.4	196.0	260.4	266.6	148.5	50
DCRE 04813s	1	70.2	64.6	83.0	74.3	80.4	71.6	82.6	76.5	155.9	143.9	351.0	267.5	292.5	299.5	166.8	50

Table 12: DCRE Drying and liquid capacity, type 48-DC

Type	No of cores	Drying capacity [kg refrigerant]										Liquid capacity [kW]					Max. working pressure p _S [bar]
		R32		R444B		R452B		R454B		R1234yf		R32	R444B	R452B	R454B	R1234yf	
		[°C]															
		24	52	24	52	24	52	24	52	24	52	24	52				
DCRE 0485s	1	55.1	50.7	65.1	58.3	63.1	56.2	64.8	60.0	122.3	112.9	102.1	77.9	85.1	69.0	48.5	50
DCRE 0487s	1	55.1	50.7	65.1	58.3	63.1	56.2	64.8	60.0	122.3	112.9	221.4	138.9	184.5	149.5	105.2	50
DCRE 0489s	1	55.1	50.7	65.1	58.3	63.1	56.2	64.8	60.0	122.3	112.9	245.9	154.3	204.9	166.0	116.9	50
DCRE 04811s	1	55.1	50.7	65.1	58.3	63.1	56.2	64.8	60.0	122.3	112.9	312.4	196.0	260.4	266.6	148.5	50
DCRE 04813s	1	55.1	50.7	65.1	58.3	63.1	56.2	64.8	60.0	122.3	112.9	351.0	267.5	292.5	299.5	166.8	50

Core selection

Table 13: Core selection

Refrigerant and oil types		DC	DM	DA
Refrigerant	HFC (R134a, R404A, R507, R407C and R410A)	Recommended	Recommended	Recommended
	HFO (R1234ze, R407F, R407A, R454C)	Recommended	Recommended	Recommended
	HCFC (R22)	Recommended	Recommended	Recommended
	R32, R444A, R444B, R445A, R446A, R447A, R451A, R452B, R454B, R455A, R1234yf	Recommended	Recommended	NA
Oil	Mineral or AB	Recommended	Recommended	Recommended
	POE or PAG, pure	Recommended	Recommended	Recommended
	POE or PAG, with additives	Not recommended ⁽¹⁾	Recommended	Recommended

⁽¹⁾ DC filter driers cores contain activated alumina, which is a polar material used for acid adsorption. Many oil additives are also polar substances and can be adsorbed by the activated alumina, rendering them useless, and reducing the drier's acid capacity, though this is not harmful to the system.

Dimensions and weights

Figure 5: DCR housing

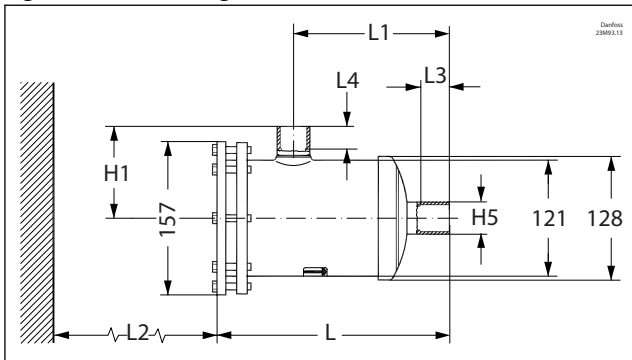
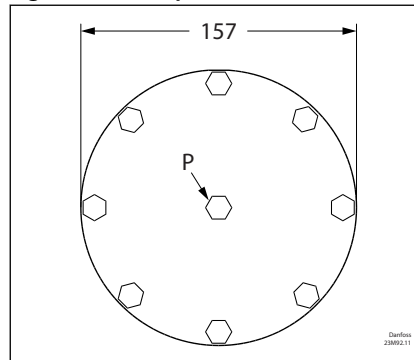

Figure 6: DCR top cover



P Plug 1/4 in. NPT

Figure 7: DCR solid core

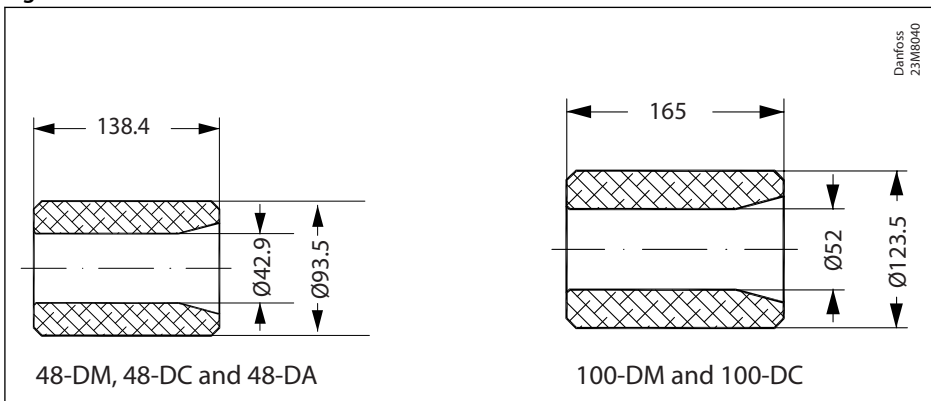

Table 14: Dimensions and weights for DCR

Type	No. of cores	DCR with steel connectors							DCR with copper connectors							Net weight ⁽¹⁾ [Kg]
		L	L1	L2	L3	L4	H1	H5	L	L1	L2	L3	L4	H1	H5	
		[mm]	[mm]	[mm]	[mm]	[mm]	[mm]	[mm]	[mm]	[mm]	[mm]	[mm]	[mm]	[mm]	[mm]	
DCR 0485(s)	1	242.9	162.7	170	12	12	96.8	21	259.9	179.7	170	12	12	112.8	19	5.2
DCR 0487(s)	1	237	156.8	170	17	17	90.3	27	259.5	179.3	170	17	17	112.8	25	5.2
DCR 0489(s)	1	240.4	160.2	170	22	22	94.3	34	261.9	181.7	170	20	20	115.8	32	5.2
DCR 0489(s)	1	240.4	160.2	170	22	22	94.3	34	261.9	181.7	170	20	20	115.8	32	5.2
DCR 04811(s)	1	242.8	162.6	170	25	25	97.3	42	264.3	184.1	170	25	25	118.8	39	5.2
DCR 04813(s)	1	248	167.8	170	29	29	103.3	48	265.5	185.3	170	29	29	120.8	46	5.2
DCR 04813(s)	1	248	167.8	170	29	29	103.3	48	265.5	185.3	170	29	29	120.8	46	5.2
DCR 04817(s)	1	253.7	173.5	170	33	33	110.8	60	267.7	187.5	170	34	34	124.8	58	5.2
DCR 04821(s)	1	256.5	176.3	170	38	38	115.8	73	269.5	189.3	170	34	34	128.8	71	5.2
DCR 0965(s)	2	381.9	301.7	310	12	12	96.8	21	398.9	318.7	310	12	12	112.8	19	6.6
DCR 0967(s)	2	376	295.8	310	17	17	90.3	27	398.5	318.3	310	17	17	112.8	25	6.6
DCR 0969(s)	2	379.4	299.2	310	22	22	94.3	34	400.9	320.7	310	20	20	115.8	32	6.6
DCR 0969(s)	2	379.4	299.2	310	22	22	94.3	34	400.9	320.7	310	20	20	115.8	32	6.6
DCR 09611(s)	2	381.8	301.6	310	25	25	97.3	42	403.3	323.1	310	25	25	118.8	39	6.6
DCR 09613(s)	2	387	306.8	310	29	29	103.3	48	404.5	324.3	310	29	29	120.8	46	6.6
DCR 09613(s)	2	387	306.8	310	29	29	103.3	48	404.5	324.3	310	29	29	120.8	46	6.6
DCR 09617(s)	2	392.7	312.5	310	33	33	110.8	60	406.7	326.5	310	34	34	124.8	58	6.6
DCR 09621(s)	2	395.5	315.3	310	38	38	115.8	73	408.5	328.3	310	34	34	128.8	71	6.6
DCR 1445(s)	3	523.9	443.7	310	12	12	96.8	21	540.9	460.7	310	12	12	112.8	19	7.8
DCR 1447(s)	3	518	437.8	310	17	17	90.3	27	540.5	460.3	310	17	17	112.8	25	7.8
DCR 1449(s)	3	521.4	441.2	310	22	22	94.3	34	542.9	462.7	310	20	20	115.8	32	7.8
DCR 1449(s)	3	521.4	441.2	310	22	22	94.3	34	542.9	462.7	310	20	20	115.8	32	7.8
DCR 14411(s)	3	523.8	443.6	310	25	25	97.3	42	545.3	465.1	310	25	25	118.8	39	7.8

Filter drier, shell, types DCR and DCRE

Type	No. of cores	DCR with steel connectors							DCR with copper connectors							Net weight ⁽¹⁾ [Kg]
		L	L1	L2	L3	L4	H1	H5	L	L1	L2	L3	L4	H1	H5	
		[mm]	[mm]	[mm]	[mm]	[mm]	[mm]	[mm]	[mm]	[mm]	[mm]	[mm]	[mm]	[mm]	[mm]	
DCR 14413(s)	3	529	448.8	310	29	29	103.3	48	546.5	466.3	310	29	29	120.8	46	7.8
DCR 14413(s)	3	529	448.8	310	29	29	103.3	48	546.5	466.3	310	29	29	120.8	46	7.8
DCR 14417(s)	3	534.7	454.5	310	33	33	110.8	60	548.7	468.5	310	34	34	124.8	58	7.8
DCR 14421(s)	3	537.5	457.3	310	38	38	115.8	73	550.5	470.3	310	34	34	128.8	71	7.8
DCR 1925(s)	4	663.9	583.7	310	12	12	96.8	21	680.9	600.7	310	12	12	112.8	19	9.1
DCR 1927(s)	4	658	577.8	310	17	17	90.3	27	680.5	600.3	310	17	17	112.8	25	9.1
DCR 1929(s)	4	661.4	581.2	310	22	22	94.3	34	682.9	602.7	310	20	20	115.8	32	9.1
DCR 1929(s)	4	661.4	581.2	310	22	22	94.3	34	682.9	602.7	310	20	20	115.8	32	9.1
DCR 19211(s)	4	663.8	583.6	310	25	25	97.3	42	685.3	605.1	310	25	25	118.8	39	9.1
DCR 19213(s)	4	669	588.8	310	29	29	103.3	48	686.5	606.3	310	29	29	120.8	46	9.1
DCR 19213(s)	4	669	588.8	310	29	29	103.3	48	686.5	606.3	310	29	29	120.8	46	9.1
DCR 19217(s)	4	674.7	594.5	310	33	33	110.8	60	688.7	608.5	310	34	34	124.8	58	9.1
DCR 19221(s)	4	677.5	597.3	310	38	38	115.8	73	690.5	610.3	310	34	34	128.8	71	9.1

⁽¹⁾ Without core. For total weight add 0.7 kg per core for 48-DM and 48-DC, 0.8 kg per core for 48-DA or 0.4 kg per strainer 48-F

Figure 8: DCRE housing

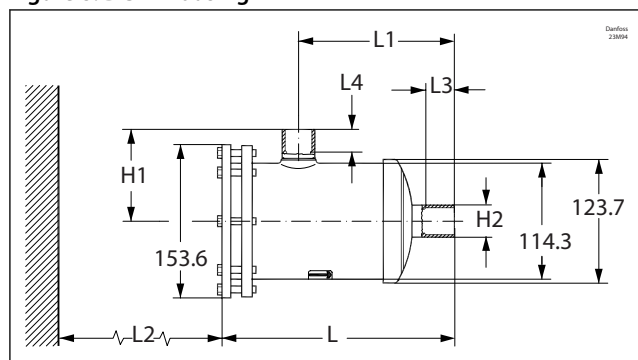
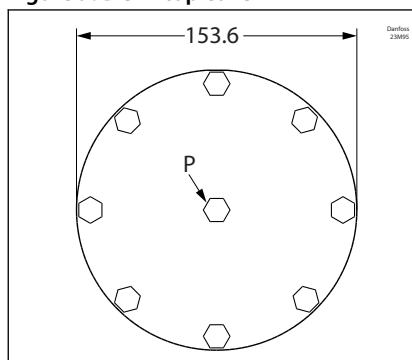

Figure 9: DCRE top cover



P Plug 1/4 in. NPT

Table 15: Dimensions and weights for DCRE

Type	No. of cores	DCRE with copper connectors							Net weight ⁽²⁾ [Kg]
		L	L1	L2	L3	L4	H1	H2	
		[mm]	[mm]	[mm]	[mm]	[mm]	[mm]	[mm]	
DCRE 0485(s)	1	219.93	152.13	170	18	18	99.85	16	4.4
DCRE 0487(s)	1	221.42	153.62	170	19	19	101.85	22.22	4.6
DCRE 0489(s)	1	228.15	160.35	170	22.5	22.5	108.85	28	4.8
DCRE 04811(s)	1	233.15	165.35	170	23.5	23.5	113.85	35	5.0
DCRE 04813(s)	1	236.15	168.35	170	27.5	27.5	116.85	41.28	5.2

⁽²⁾ Without core. For total weight add 0.7 kg per core for 48-DM and 48-DC, 0.8 kg per core for 48-DA or 0.4 kg per strainer 48-F

Ordering

DCR/DCRE housing and insert are ordered separately. Select housing and top cover with all internal parts assembled from table 1,2 or 3 and required number of inserts from table 4.

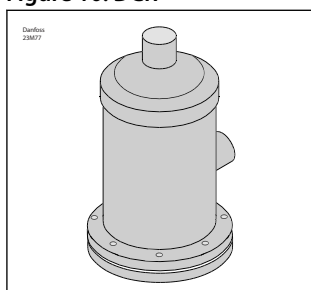
Figure 10: DCR

Table 16: DCR Housing with copper connectors + top cover

Type	Number of cores	Copper connectors		Cover type	Max. working pressure PS	Code number
		Solder ODF				
		[in.]	[mm]		[bar]	
DCR 0485s	1	5/8	16	Plug	46	023U7250
DCR 0487s	1	7/8	22	Plug	46	023U7251
DCR 0487s	1	7/8	22	-	46	023U7571
DCR 0489s	1	-	28	Plug	46	023U7252
DCR 0489s	1	1 1/8	-	Plug	46	023U7253
DCR 0489s	1	-	28	-	46	023U7268
DCR 04811s	1	1 3/8	35	Plug	46	023U7254
DCR 04813s	1	1 5/8	-	Plug	46	023U7255
DCR 04813s	1	-	42	Plug	46	023U7256
DCR 04813s	1	-	42	-	46	023U7303
DCR 04817s	1	2 1/8	54	Plug	46	023U7257
DCR 04821s	1	2 5/8	-	Plug	46	023U7276
DCR 0967s	2	7/8	22	Plug	46	023U7258
DCR 0969s	2	-	28	Plug	46	023U7259
DCR 0969s	2	1 1/8	-	Plug	46	023U7260
DCR 0969s	2	1 1/8	-	-	46	023U7278
DCR 09611s	2	1 3/8	35	Plug	46	023U7261
DCR 09613s	2	1 5/8	-	Plug	46	023U7262
DCR 09613s	2	-	42	Plug	46	023U7263
DCR 09613s	2	-	42	-	46	023U7463
DCR 09617s	2	2 1/8	54	Plug	46	023U7264
DCR 09617s	2	2 1/8	54	-	46	023U7290
DCR 09621s	2	2 5/8	-	Plug	46	023U7281
DCR 1449s	3	-	28	Plug	35 ⁽¹⁾ / 46 ⁽²⁾	023U7265
DCR 14411s	3	1 3/8	35	Plug	35 ⁽¹⁾ / 46 ⁽²⁾	023U7267
DCR 14411s	3	1 3/8	-	-	35 ⁽¹⁾ / 46 ⁽²⁾	023U7275
DCR 14413s	3	1 5/8	-	Plug	35 ⁽¹⁾ / 46 ⁽²⁾	023U7282
DCR 14413s	3	-	42	Plug	35 ⁽¹⁾ / 46 ⁽²⁾	023U7269
DCR 14413s	3	1 5/8	42	-	35 ⁽¹⁾ / 46 ⁽²⁾	023U7297
DCR 14417s	3	2 1/8	54	Plug	35 ⁽¹⁾ / 46 ⁽²⁾	023U7270
DCR 19211s	4	1 3/8	-	-	28 ⁽¹⁾ / 40 ⁽²⁾	023U7083
DCR 19213s	4	1 5/8	-	Plug	28 ⁽¹⁾ / 40 ⁽²⁾	023U7272
DCR 19213s	4	-	42	Plug	28 ⁽¹⁾ / 40 ⁽²⁾	023U7273
DCR 19213s	4	1 5/8	-	-	28 ⁽¹⁾ / 40 ⁽²⁾	023U7082
DCR 19217s	4	2 1/8	54	Plug	28 ⁽¹⁾ / 40 ⁽²⁾	023U7274

⁽¹⁾ For usage with strainer or as a receiver application

⁽²⁾ For "drier" application using all the permissible cores

Filter drier, shell, types DCR and DCRE

Figure 11: DCR

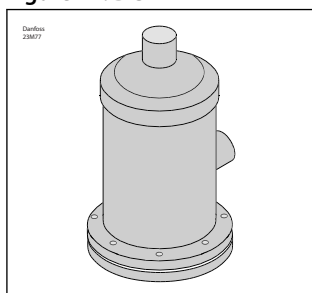

Table 17: DCR Housing with steel connectors + top cover

Type	Number of cores	Steel connectors			Cover type	Max. working pressure PS	Code number
		Solder ODF		Butt weld			
		[in.]	[mm]	[in.]		[bar]	
DCR 0485	1	5/8	16	1/2	Plug	46	023U7050
DCR 0487	1	7/8	22	3/4	Plug	46	023U7051
DCR 0487	1	7/8	22	3/4	–	46	023U7151
DCR 0489	1	–	28	1	Plug	46	023U7052
DCR 0489	1	1 1/8	–	1	Plug	46	023U7053
DCR 04811	1	1 3/8	35	1 1/4	Plug	46	023U7054
DCR 04813	1	1 5/8	–	1 1/2	Plug	46	023U7055
DCR 04813	1	–	42	1 1/2	Plug	46	023U7056
DCR 04817	1	2 1/8	54	2	Plug	46	023U7057
DCR 04821	1	2 5/8	–	2 1/2	Plug	46	023U7076
DCR 0967	2	7/8	22	3/4	Plug	46	023U7058
DCR 0969	2	–	28	1	Plug	46	023U7059
DCR 0969	2	1 1/8	–	1	Plug	46	023U7060
DCR 09611	2	1 3/8	35	1 1/4	Plug	46	023U7061
DCR 09611	2	1 3/8	35	1 1/4	–	46	023U7161
DCR 09613	2	1 5/8	–	1 1/2	Plug	46	023U7062
DCR 09613	2	–	42	1 1/2	Plug	46	023U7063
DCR 09617	2	2 1/8	54	2	Plug	46	023U7064
DCR 1449	3	–	28	1	Plug	35 ⁽¹⁾ / 46 ⁽²⁾	023U7065
DCR 1449	3	1 1/8	–	1	Plug	35 ⁽¹⁾ / 46 ⁽²⁾	023U7066
DCR 14411	3	1 3/8	35	1 1/4	Plug	35 ⁽¹⁾ / 46 ⁽²⁾	023U7067
DCR 14413	3	1 5/8	–	1 1/2	Plug	35 ⁽¹⁾ / 46 ⁽²⁾	023U7068
DCR 14413	3	–	42	1 1/2	Plug	35 ⁽¹⁾ / 46 ⁽²⁾	023U7069
DCR 14417	3	2 1/8	54	2	Plug	35 ⁽¹⁾ / 46 ⁽²⁾	023U7070
DCR 19211	4	1 3/8	35	1 1/4	Plug	28 ⁽¹⁾ / 40 ⁽²⁾	023U7071
DCR 19213	4	1 5/8	–	1 1/2	Plug	28 ⁽¹⁾ / 40 ⁽²⁾	023U7072
DCR 19213	4	–	42	1 1/2	Plug	28 ⁽¹⁾ / 40 ⁽²⁾	023U7073
DCR 19217	4	2 1/8	54	2	Plug	28 ⁽¹⁾ / 40 ⁽²⁾	023U7074
DCR 19221	4	2 5/8	–	2 1/2	Plug	28 ⁽¹⁾ / 40 ⁽²⁾	023U7086

⁽¹⁾ For usage with strainer or as a receiver application

⁽²⁾ For "drier" application using all the permissible cores

Filter drier, shell, types DCR and DCRE

Figure 12: DCRE

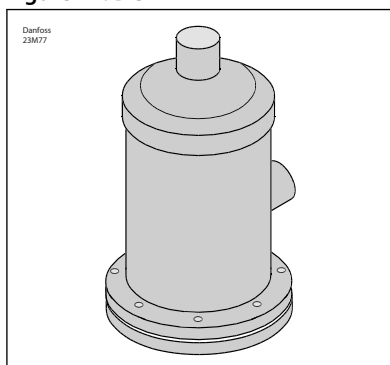

Table 18: DCRE Housing with copper connectors + top cover

Type	Number of cores	Copper connectors solder		Cover	Maximum working pressure PS	Code number
		[in]	[mm]		[bar]	
DCRE 0485s	1	5/8	16	plug	50	023U7608
DCRE 0487s	1	7/8	22	plug	50	023U7606
DCRE 0489s	1	1 1/8	–	plug	50	023U7607
DCRE 0489s	1	–	28	plug	50	023U7609
DCRE 04811s	1	1 3/8	35	plug	50	023U7610
DCRE 04813s	1	1 5/8	41	plug	50	023U7611

Figure 13: DCR insert Figure 14: DCRE insert

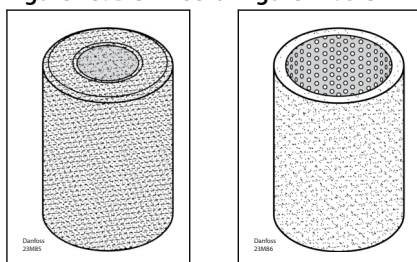

Table 19: Type DCR/DCRE, inserts

Type	Material	Code number for DCR			Code number for DCRE
		Industrial pack		Multi pack	Multi pack
		(8 pcs.)		(3 pcs.)	(3 pcs.)
		with gasket ⁽²⁾	without gasket	with gasket ⁽²⁾	with gasket ⁽²⁾
48-DM solid core ⁽¹⁾	100% molecular sieve	023U1392	023U1393	023U1391	023U1399
48-DC solid core ⁽¹⁾	80% molecular sieve & 20% Al ₃ O ₂	023U4381	023U4382	023U4380	023U4388
48-DA solid core ⁽¹⁾	30% molecular sieve & 70% Al ₃ O ₂	023U5381	023U5382	023U5380	–
48-F strainer ⁽¹⁾	Felt-gasket, 15 µm	023U1921	–	–	–
100-DM solid core ⁽¹⁾	100% molecular sieve	023U7562	–	–	–
100-DC solid core ⁽¹⁾	80% molecular sieve & 20% Al ₃ O ₂	023U7563	–	–	–

⁽¹⁾ Only use for DCR 048 - 192 housing

⁽²⁾ Top cover gasket

Table 20: Core surface and volume

Core	surface	volume
	[cm ²]	[cm ³]
DM 048, DC 048 and DA 048	612	727
DM 096, DC 096 and DA 096	1225	1454
DM 144, DC 144 and DA 144	1837	2181
DM 192, DC 192 and DA 192	2450	2908
48-F	405	-

Certificates, declarations, and approvals

The list contains all certificates, declarations, and approvals for this product type. Individual code number may have some or all of these approvals, and certain local approvals may not appear on the list.

Some approvals may change over time. You can check the most current status at danfoss.com or contact your local Danfoss representative if you have any questions.

Table 21: Certificates, declarations, and approvals

Document name	Document type	Document topic	Approval authority
PV 6-238699.19	Pressure - Safety Certificate		NSW
PV 6-238700.19	Pressure - Safety Certificate		NSW
PV 6-238701.19	Pressure - Safety Certificate		NSW
PV 6-238702.19	Pressure - Safety Certificate		NSW
SA6398	Mechanical - Safety Certificate	cULuslisting	UL
023U9601	Manufacturers Declaration	China RoHS	Danfoss
023U9611	Manufacturers Declaration	RoHS	Danfoss
023U9612	EU Declaration	PED	Danfoss
023U9613	Manufacturers Declaration	ATEX/PED/RoHS	Danfoss
023U9631	Manufacturers Declaration	PED/RoHS	Danfoss
RU Д-DK.PA01.B.32851_20	EAC Declaration	PED	EAC
RU Д-DK.БЛ08.B.00828_19	EAC Declaration	Machinery & Equipment	EAC

Online support

Danfoss offers a wide range of support along with our products, including digital product information, software, mobile apps, and expert guidance. See the possibilities below.

The Danfoss Product Store



The Danfoss Product Store is your one-stop shop for everything product related—no matter where you are in the world or what area of the cooling industry you work in. Get quick access to essential information like product specs, code numbers, technical documentation, certifications, accessories, and more.

Start browsing at store.danfoss.com.

Find technical documentation



Find the technical documentation you need to get your project up and running. Get direct access to our official collection of data sheets, certificates and declarations, manuals and guides, 3D models and drawings, case stories, brochures, and much more.

Start searching now at www.danfoss.com/en/service-and-support/documentation.

Danfoss Learning



Danfoss Learning is a free online learning platform. It features courses and materials specifically designed to help engineers, installers, service technicians, and wholesalers better understand the products, applications, industry topics, and trends that will help you do your job better.

Create your Danfoss Learning account for free at www.danfoss.com/en/service-and-support/learning.

Get local information and support



Local Danfoss websites are the main sources for help and information about our company and products. Find product availability, get the latest regional news, or connect with a nearby expert—all in your own language.

Find your local Danfoss website here: www.danfoss.com/en/choose-region.

Coolselector®2 - find the best components for you HVAC/R system



Coolselector®2 makes it easy for engineers, consultants, and designers to find and order the best components for refrigeration and air conditioning systems. Run calculations based on your operating conditions and then choose the best setup for your system design.

Download Coolselector®2 for free at coolselector.danfoss.com.

Any information, including, but not limited to information on selection of product, its application or use, product design, weight, dimensions, capacity or any other technical data in product manuals, catalogues descriptions, advertisements, etc. and whether made available in writing, orally, electronically, online or via download, shall be considered informative, and is only binding if and to the extent, explicit reference is made in a quotation or order confirmation. Danfoss cannot accept any responsibility for possible errors in catalogues, brochures, videos and other material. Danfoss reserves the right to alter its products without notice. This also applies to products ordered but not delivered provided that such alterations can be made without changes to form, fit or function of the product. All trademarks in this material are property of Danfoss A/S or Danfoss group companies. Danfoss and the Danfoss logo are trademarks of Danfoss A/S. All rights reserved.