

ENGINEERING
TOMORROW

Danfoss

Danfoss Waltech® Tube Fitting Series and Assembly Machines



Tube Fitting **Trilogy**



Reliable and leak free performance, supported by:

- The quality of the tube fitting, as well as its behavior in an assembly – such as its reliability in tough conditions, pressure resistance, strength and safety.
- Repeatable accuracy of assembly, even with untrained personnel, and leak free assembly behavior.
- High corrosion resistance that ensures reliability of assembly.



A broad range of market applications and certifications that prove reliability in different conditions.



Access to a complete tube fitting portfolio from one supplier that can meet any tube fitting needs, while also ensuring consistent performance and superior reliability.



Walpro®
METALLIC
SEAL CUTTING
RING

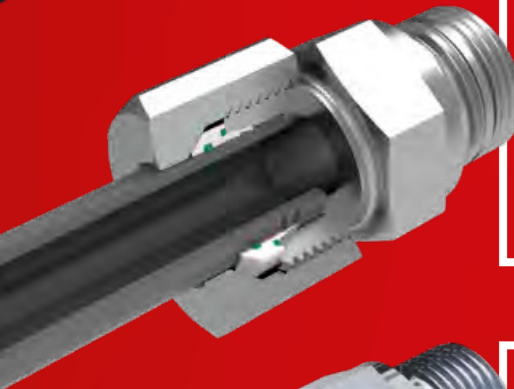

WalringPlus®
SOFT SEAL
CUTTING RING

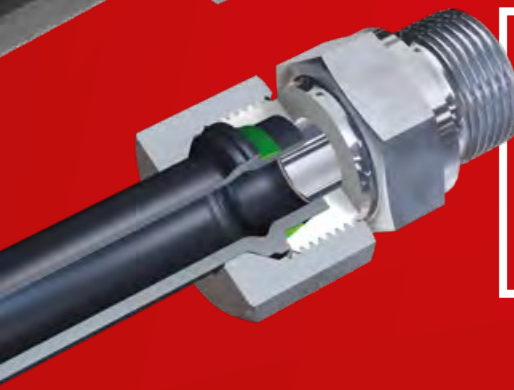

Walform®
RESHAPING
SYSTEM

Welcome to **Waltech** tube fitting system

For any tube fitting system, your top priority has to be reliability. That's why our Waltech series ensures excellent performance by combining robust, leak-free design with high bending and impulse resistance.

Our Walpro, WalringPlus, Walform tube fitting systems offer a complete solution for any needs. With three different ways to create a connection, our systems can meet a wide range of application challenges.

Waltech's design features enable simple, safe, and repeatable manual assembly—but our bespoke assembly machines also reduce errors and make assembly quicker and easier. Meanwhile, our unique Guardian Seal surface plating enables high corrosion resistance without affecting assembly strength.

To help ensure ease-of-use and outstanding results, we also support our Waltech series with an array of end-to-end services—including machine rental, maintenance and operator training.



Waltech tube fittings at a glance

- A complete solution for any tube fitting needs in carbon steel and stainless steel (1.4571)
- Highest operating pressures up to 800 bar
- Available in 6-42 mm tube diameters
- All parts built to DIN EN ISO 8434-1 for 24° fittings
- Manual or machine assembly
- Exceptional durability and stability
- 4:1 safety factor
- Broad supporting services

Walpro
METALLIC
SEAL CUTTING
RING

WalringPlus
SOFT SEAL
CUTTING
RING

Walform
RESHAPING
SYSTEM



TECHNOLOGY

Two-edge cutting ring (profile ring), controlled final assembly

Two-edge cutting ring with captive seal, machine assembly

Cold reshaping of the tube end with captive seal

SYSTEM FEATURES

Force closure, combined sealing and retaining functions

Force closure, separate sealing and retaining functions

Form closure, separate sealing and retaining functions

SEALING PRINCIPLE

Metal-on-metal

Elastomeric + Metal-on-metal

Elastomeric + Metal-on-metal

PREFABRICATION

Assembly machine

Assembly machine

Reshaping machine

TIGHTENING TRAVEL FOR FINAL IN SERVICE ASSEMBLY

30°–60° after controlled final assembly

30°–60° after machine assembly

Up to the point of resistance

TORQUE REDUCTION

≈ 25% compared to manual assembly

≈ 25% compared to manual assembly of a cutting ring

> 25% compared to manual assembly of a cutting ring

RISK OF ASSEMBLY RELATED FAILURES

Minimal with controlled final assembly machine

Minimal with machine assembly

Minimal

Find the right fit for your needs

All three Waltech tube fitting systems can meet the most demanding application requirements—including those in the Agriculture, Alternative Energy, Construction, Manufacturing, Mobile Material Handling, Offshore & Marine, Oil & Gas, and Transportation industry segments.

Walpro



Choose Walpro tube fittings if you need a cost-efficient and easy solution that also allows manual assembly.

Featuring a unique design with a two-edge cutting ring, the Walpro system has improved dynamic load resistance and ensures leak-free operations. It enables exceptional performance and short bending lengths for greater application flexibility. Ease of assembly and re-assembly is guaranteed thanks to Walpro's special design, which creates an unmistakable pressure point that clearly indicates the end of the assembly travel—making excessive or insufficient tightening very unlikely.

WalringPlus



Choose Walring tube fittings if soft sealing and short bending lengths are required.

The Waltech WalringPlus tube fitting features a two-edge cutting ring with additional soft sealing for both possible leak paths. Specifically optimized for thin wall tubing, it's designed to enable easy, repeatable assembly and to prevent the possible causes of leaks for dependable in-application performance.

Walform



Choose Walform tube fittings for the most demanding, high pressure and high vibration applications where safety is crucial.

Walform tube connector ensures leak free performance through double sealing (soft-seal and metal-to-metal) and is specifically engineered to ensure lasting reliability even under loads with high dynamic pressure and vibration.

Walpro and WalringPlus tube fittings feature

- Elastomeric and metal-on-metal sealing
- Prefabrication by hand or with a machine
- Controlled final assembly with the M-R7 machine
- Suited for short bending lengths
- Approved for use with Benteler ZISTA SEAL® and ZISTAPLEX® tubes

Additional Walform Tube fittings feature:

- Proprietary Danfoss forming machine for tube end
- Qualified for wide range of steel and stainless steel tube materials

Waltech Tube Fitting Series

Designed to deliver

As an innovator in tube connectors, our Waltech series offers superior design—enabling exceptional performance in a wide range of applications. Our design features go well beyond simple metallic sealing cutting ring systems to deliver the best possible performance and leak-free operations.

WalringPlus design benefits

- Some cutting rings with inner soft seals can be difficult and slower to assemble due to friction between the inner O-ring and the tube's outer surface. The unique inner design of WalringPlus means a significantly lower force is needed to pull the cutting ring over the tube – enabling easier assembly and a reduced risk of damage to the soft seal.
- Where many tube fitting systems require time-consuming and messy lubrication for all components, this is not necessary for Waltech components in carbon steel. This dry assembly process makes tube fitting assembly easier, faster, and cleaner.
- The O-ring groove design of WalringPlus enables an improved stress curve in the material, which increases its mechanical resistance compared to other soft seal cutting rings on the market. This eliminates the risk of the cutting ring cracking during assembly.
- With the bulk of material in front of the first cutting edge, WalringPlus allows for visible control over assembly to reduce the risk of leaks.
- By automating the process of cutting ring assembly and tube forming, Danfoss bespoke WALTRECH M-R7 machine reduces the assembly time and effort required for WalringPlus, as well as the risk of leaks.

Walpro design benefits

- Operators 'feel' when assembly is complete and overtightening is unmistakable, thanks to steadily rising tightening torque with a limit stop feature.
- Increased resistance to high dynamic loads through axial ribs, inner area clamping along the complete tube length, and cutting edges that equally share the holding force.
- Optimized sealing efficiency due to a complete connection between the cutting ring and tube surface. High sealing stress also results in a lower likelihood of leakage.
- Superior assembly characteristics due to cutting edge angles and two cutting edges.
- Safe connections even after repeated assembly. The metallic sealing cutting ring can be assembled and disassembled as often as necessary.
- Lower expenditure, thanks to a reduced need to replace nuts and bodies.

Walform design benefits

- Patented nose design provides secondary metallic sealing to eliminate any risk of leakage in the only possible path.
- Positive locking between the stud and tube ensures absolute reliability under extreme dynamic loads.
- Locked-in retaining tube removes any risk of disconnection and enables Walform to be used in safety-critical applications.
- No turning of the tube during the assembly process eradicates the risk of assembly failure.

Ensuring **exceptional performance**

All our Waltech fittings are designed to meet the toughest application demands for strength, pressure resistance and reliability. OEMs with very stringent requirements choose Waltech, given our extensive safety and hazardous environment approvals. We also offer a two-year warranty for all components.

Reliable raw materials

To support the most demanding tube fitting needs, the Waltech series uses for critical components high-quality raw materials that ensure in-application reliability:

- High tensile steel grades are used that reduce the variance of material properties.
- Purity analysis to EN 50602 and ISO 10247 standards is undertaken with every batch of materials to ensure its properties meet requirements.
- Ultrasonic crack detection is done for barstock material, according to DIN EN 10277 standards, to prevent the occurrence of microcracks in the material.

Pressure resistance

All three Waltech systems can withstand the highest pressures.

- Waltech was the first tube fitting system to support operating pressures of up to 800 bar, and all three systems have the same high pressure resistance.
- Waltech systems are available in L Series fittings, rated up to 500 bar, or S Series fittings, rated up to 800 bar.
- Our carbon steel fittings are calibrated for the highest working pressures.

Vibration and bending resistance

Our tube connector series is designed and tested for excellent resistance to vibration and bending stress.

- Walpro: The tube is clamped over its complete length to compensate for vibration and is held in place by a stable bulk of material in front of the first edge.
- WalringPlus: Two cutting edges share the holding force equally, enabling greater resistance against high dynamic loads and are optimized for thin wall tubing.
- Walform: Cold forming of materials increases stress resistance at the most crucial points of the tube. Combined with no sharp ending, this creates outstanding vibration resistance.
- Walformplus-SR: Extends Walform's advantages to thin wall tubing, with an additional support ring behind the formed tube which increases vibration and bending stress resistance.
- Walformplus-M: Enables metallic sealing without a soft seal, for applications with aggressive media or very high temperatures.

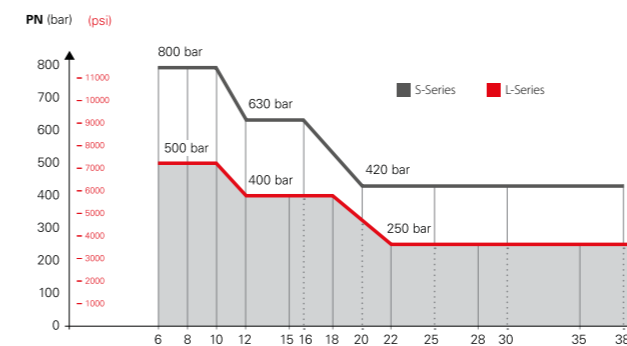

Engineered for easy assembly

Correct assembly is crucial to tube fitting performance. That's why our Waltech systems make assembly simple, fast, and safe.

By offering the same assembly behavior for all systems, our Waltech tube fittings make correct assembly easy for operators. This includes short assembly travel, lower tightening torque, an unmistakable pressure point to prevent over or under-assembly, and unlimited reassembly with no performance impact.

Waltech's assembly advantages

- All three Waltech systems can be assembled with the similar short 30-60° turn in all sizes, requiring less manual effort or machine time to assemble.
- Considerably lower tightening torque and an unmistakable torque increase at the end of assembly prevents overtightening and aids precision.
- After cutting ring system assembly, the visible bulk of removed material makes it easy to check everything is correct.
- Assembly can be repeated any number of times with no impact on performance.
- Dry assembly (no lubrication required) for carbon steel fittings.

Final in service assembly after prefabrication
(All Waltech systems)

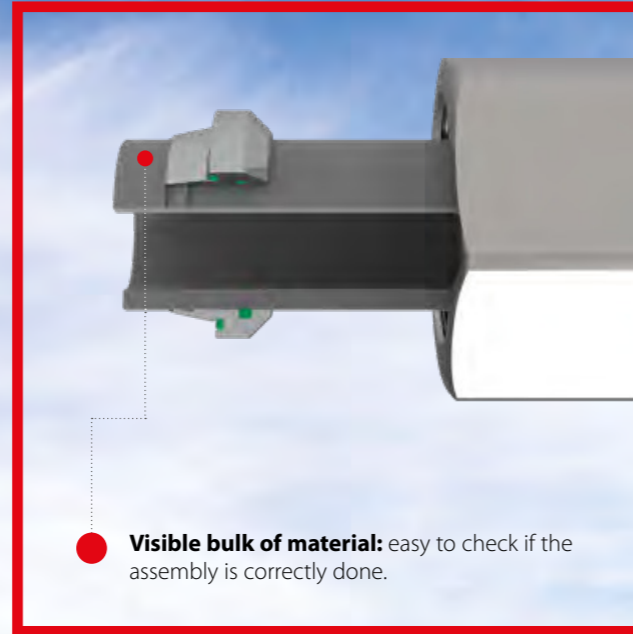
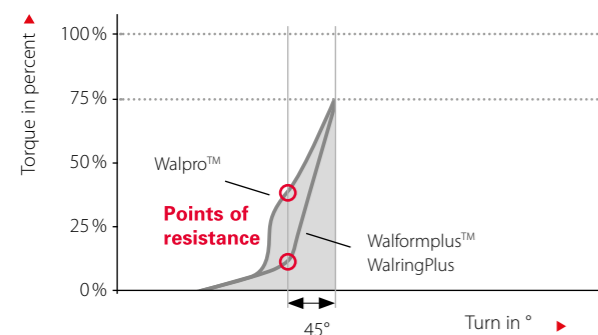

High performance assembly machines

To further reduce the assembly time and effort required and help ensure optimum performance, we've also developed our own Waltech machines to automate the process of cutting ring assembly and tube forming.

- Our innovative M-R7 machine is designed for final assembly of our Walpro and WalringPlus systems. It offers optimized performance and installation advantages, resulting in a short tightening movement and reduced force required at the final stage of the service assembly.
- Our reliable M-WF385Xplus machine is designed for the most demanding applications, enabling tube forming for the Walform system in steel and stainless steel (1.4571). It enables additional sealing, easy machine assembly, and robust performance.

M-R7 features and benefits

- Final assembly of Walpro and WalringPlus tube fittings from 6-42mm
- Fast cycle times allow efficient and economical production
- Able to process extremely tight bent tubes and short straight tube ends
- Automatic pressure point detection and way control ensures accurate and reliable assembly
- RFID-technology for tool detection and setting of process values
- Optimized error detection with self-programmed limits based on statistical process control
- Unmissable error messages that require acknowledgment
- Automatic assembly by pushing the tube through the tool
- Export assembly parameters via a USB port for integration into quality systems

M-WF385Xplus features and benefits

- Final assembly of Walform tube connectors from 6-42 mm
- Fast cycle times allow efficient and economical production
- Reduced set-up time thanks to easy tool changes
- Compact, low-weight design for easy transportation on the shop floor
- Robust design reduces downtime and enables a longer machine lifetime
- Forming pressure control reduces energy consumption and extends machine lifetime
- Quieter performance for reduced noise level in the shop floor
- Color-coded tools to avoid mistakes in the forming process



Guardian Seal plating

Guardian Seal is our exceptional, zinc-based surface treatment applied by electroplating. It guarantees excellent, durable protection from corrosion and meets DIN EN ISO 9227 standards—while also being easy to assemble, and better for health and the environment.

The 11-15 µm zinc layer is passivated through a specialized process, resulting in an open-pored structure. Organic micro-particles are then impregnated into this structure in an optimized emersion process. Finally, the cross-linked polymerization of the top layer is completed via a unique curing procedure.

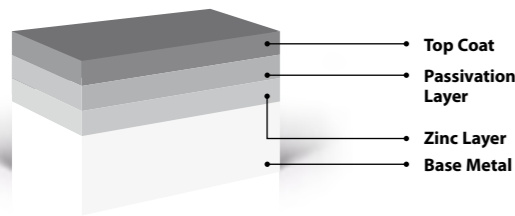

Guardian Seal coating in salt spray test according to DIN EN ISO 9227



Key features

- Lower assembly and disassembly torque and reduced torque variance
- >360 hours resistance to white corrosion and >1000 hours to red corrosion
- Nickel and chromium-6 free
- Torque value is the same as Chromium-3
- High quality shiny silver appearance
- Resistant to commonly used hydraulic fluids
- Paintable with commercially available coatings

Key benefits

- Guarantees excellent, durable corrosion protection
- Safer and easier assembly and disassembly
- No risk of nickel dust during assembly and handling
- No risk of contact allergies
- Wastewater from the plating process requires less treatment

Our supporting services

Our Waltech series relies on the proven capabilities at our major manufacturing and distribution facility in Lohmar, Germany—where we produce all our Walpro, WalingPlus and Walform tube connector lines.

With in-house expertise spanning design, testing and production, we can deliver much greater lifecycle value to customers. We offer customers a wide range of support services—including high-end test capabilities, inspection, maintenance, repairs, backfitting, rentals and operator training.

Testing to the extremes

- Our Waltech development and testing programs go to extremes to ensure exceptional performance. We have all the expertise and test equipment needed to validate new products and tubing materials in-house.
- We can design components for specific customer applications and test them in a simulated environment to ensure they offer the best possible solution.
- The Waltech development and testing programs were designed to ensure top-notch performance, as well as help our customers meet specific application needs. They include:
 - A combined pressure/impulse and reversed bending test
 - A tensile test to failure, with confirmation of the fitting's stripping resistance
 - A fire resistance test to DIN EN ISO 19921 with exposure to flame
 - The Walpro test program helium test for leakage resistance
 - The Walformplus test program shock and gas pressure tests for military and marine applications

Training for success

- As well as increasing time and cost requirements, insufficient knowledge or a lack of training can cause errors in assembly, leakages, and even safety issues.
- We offer customers expert training for both our tube fitting systems and assembly machines.
- Training can be held at either our Lohmar facility or at customer locations.

Troubleshooting any issues

- Our service team regularly checks both rented or purchased tools and machines at customer sites.
- Our engineering team can visit customers to understand their applications, measure performance, and optimize routing and connections to resolve issues.
- We have a large rental pool of machines available to support customer projects or offer replacements in case maintenance is needed.
- Our machine warranty can be extended up to three years and, if a rental machine breaks down, a substitute can be issued subject to the terms of the rental contract.
- We have various options available for the maintenance and backfitting of older assembly machines.



Six reasons to choose Waltech

- Excellent performance: no leaks and high bending, impulse and corrosion resistance
- A complete solution for any tube fitting needs
- Manual assembly that's straightforward, safe and repeatable
- Machine assembly that's quicker, easier and can reduce errors
- In-house supporting services spanning application testing, maintenance, training and more
- Danfoss's global footprint, excellent application references and customer success stories

Go to www.danfoss.com for further product information.

Danfoss Power Solutions (US) Company

2800 East 13th Street
Ames, IA 50010, USA
Phone: +1 515 239 6000

Danfoss Power Solutions II GmbH

Hauptstrasse 150
53797 Lohmar, Germany
Phone: +49 2246 1009101

Danfoss Power Solutions ApS

Nordborgvej 81
DK-6430 Nordborg, Denmark
Phone: +45 7488 2222

Danfoss Power Solutions Trading (Shanghai) Co. Ltd.

Building #22, No. 1000 Jin Hai Rd
Jin Qiao, Pudong New District
Shanghai, China 201206
Phone: +86 21 3418 5200