

Data sheet

Actuators for modulating control AME 85, AME 86

Description



The actuators AME 85 and AME 86 are used with VFM 2 (DN 150-250), VFS 2 (DN 65-100), VF2/3 (DN 125, 150) and AFQM (DN150-250) valves.

Features:

- “Self stroking” function
- Load related “Switch off” function that prevents overloading
- Manual operation
- Diagnostic LED

Main data:

- Nominal voltage:
 - 24 VAC , 50 Hz/60 Hz
- Control input signal:
 - 0(4)-20 mA
 - 0(2)-10 V
- Force: 5000 N
- Stroke: 40 mm
- Speed: 8 s/mm (AME 85), 3 s/mm (AME 86)
- Max. medium temperature: 200 °C
- Manual operation

Ordering

Actuator

Type	Power supply	Speed	Code No.
AME 85	24 V~	8 s/mm	082G1452
AME 86	24 V~	3 s/mm	082G1462

Accessories

Type	Code No.
Stem heater	065Z7021
AM-PBU 25 - Power backup unit	082H7090

Technical data

Type		AME 85	AME 86
Power supply	V	24 AC +10 to -15%	
Power consumption	VA	12.5	25
Frequency	Hz	50 / 60	
Control input Y	V	0 to 10 (2 to 10) Ri = 50 Ω,	
	mA	0 to 20 (4 to 20) Ri = 500 Ω	
Output signal X	V	0 to 10 (2 to 10)	
EMC		IEC 801/2 - 5	
Closing force	N	5000	
Max. stroke	mm	40	
Speed	s/mm	8	3
Max. medium temperature	°C	200	
Ambient temperature		0 to 55	
Storage and transport temperature		-40 to +70	
Protection Class		III (24 V)	
Grade of enclosure		IP 54	
Weight	kg	9.8	10.0
 - marking in accordance with the standards		Low Voltage Directive 73/23/EEC and 93/68/EEC, EN 60730/2/14	
		EMC Directive 89/336/EEC, 92/31/EEC, 93/68/EEC, EN 50081-1 and EN 50082-1	

Installation

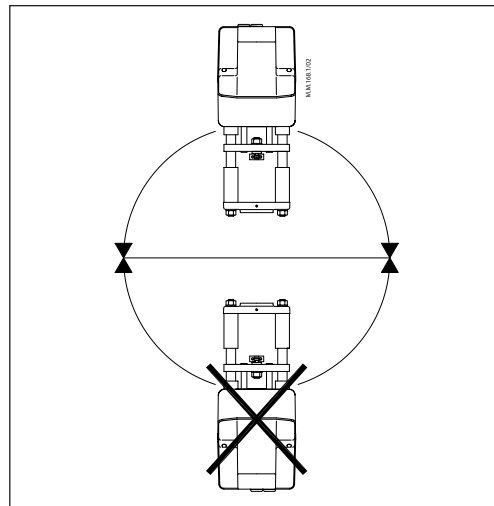

Mechanical

The actuator should be mounted with the valve stem in either horizontal position or pointing upwards. Use the 57 mm castellated nut (supplied) to fit the actuator to the valve body. While the actuator is being fitted, a 8 mm Allen key can be used to tighten the pinch screw in the valve body ring to stop the valve turning.

Allow for necessary clearance for maintenance purposes.

Electrical

Electrical connections can be accessed by removing the cover. Two M16 x 1.5 cable entries are provided. Both entries are provided with a rubber grommet for use with flexible cable. Note that in order to maintain the enclosure IP rating, appropriate cable glands must be used.

DIP switch setting

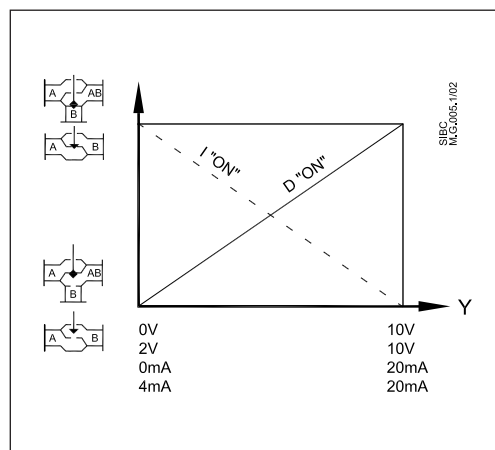
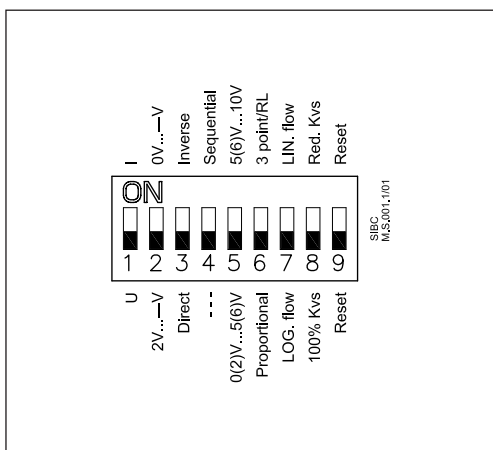

The actuator has a function selection DIP switch under the removable cover. In particular, if SW6 is set to ON, the actuator will perform as 3-point actuator.

The switch provides the following functions:

• **SW1: U/I - Input signal type selector:**

If set to OFF position, voltage input is selected. If set to ON position, current input is selected.

• **SW2: 0/2 - Input signal range selector:**

If set to OFF position, the input signal is in the range from 2 V to 10 V (voltage input) or from 4 mA to 20 mA (current input). If set to ON position, the input signal is in the range from 0 V to 10 V (voltage input) or from 0 mA to 20 mA (current input).

• **SW3: D/I - Direct or inverse acting selector:**

If set to OFF position, the actuator is direct acting (stem lowers as voltage increases). If actuator is set to ON position the actuator is inverse acting (stem raises as voltage increases).

• **SW4: —/Seq - Normal or sequential mode selector:**

If set to OFF position, the actuator is working in range 0(2)..10V or 0(4)..20mA. If set to ON position, the actuator is working in sequential range: 0(2)..5 (6)V or 0(4)..10 (12)mA or 5(6)..10V or 10(12)..20mA).

• **SW5: 0..5V/5...10V - Input signal range in sequential mode:**

If set to OFF position, the actuator is working in sequential range 0(2)..5 (6)V or 0(4)..10 (12)mA. If set to ON position, the actuator is working in sequential range; 5(6)..10V or 10(12)..20mA.

• **SW6: Prop./3-pnt - Modulating or 3-point mode selector:**

If set to OFF position, the actuator is working normally according to control signal. If set to ON position, the actuator is working as 3-point actuator.

• **SW7: LOG/LIN - Equal percentage or linear flow through valve selector¹:**

If set to OFF position, the flow through valve is equal percentage. If set to ON position, the flow through valve is linear according to control signal.

• **SW8: 100% K_{vs}/Reduced K_{vs} - Flow reduction through valve selector¹:**

If set to OFF position, the flow through valve is not reduced. If set to ON position, the flow through valve reduced by half of increment standard K_{vs} values (example: valve with K_{vs} 16 and SW8 set to ON – maximum flow through the valve is K_{vs} 13 (middle between standard K_{vs} 16 and K_{vs} 10)).

¹ NOTE: To be used only in combination with valves with equal percentage characteristic.

• **SW9: Reset:**

Changing this switch position will cause the actuator to go through a self stroking cycle.

Wiring



24 Vac only.

Wiring length	Recommended square of the wiring
0 - 50 m	0.75 mm ²
> 50 m	1.5 mm ²

Automatic self stroking feature

When power is first applied, the actuator will automatically adjust to the length of the valve stroke. Subsequently, the self stroking feature can be re-initialised by changing position of SW9.

Diagnostic LED

The red diagnostic LED is located on the pcb under the cover. It provides indication of three operational states:

- Actuator Healthy (Permanently ON),
- Self Stroking (Flashes once per second),
- Error (Flashes 3 times per second - seek technical assistance).

DIP 6 = OFF

SN	0 V	Neutral
SP	24 VAC	Power supply
Y	0(2)-10 VAC	Input
	0(4)-20 mA	
1	24 VAC	Input
3		Input
X	0(2)-10 V	Output

Controller with relay output

DIP 6 = ON

SN	0 V	Neutral
SP	24 VAC	Power supply
1	24 VAC	Input
3		Input
X	0(2)-10 VDC	Output

Controller with triacs output

DIP 6 = ON

SN	24 V	Power supply
SP	0 V	Neutral
1	24 VAC	Input
3		Input

Commissioning

Complete the mechanical and electrical installation and perform the necessary checks and tests:

- Isolate control medium. (e.g. self stroking in a steam application without suitable mechanical isolation could cause a hazard).
- Apply the power. Note that the actuator will now perform the self stroking function.
- Apply the appropriate control signal and check the valve stem direction is correct for the application.
- Ensure that the actuator drives the valve over its full stroke, by applying the appropriate control signal. This action will set the valve stroke length.

The unit is now fully commissioned.

Commissioning / testing feature

The actuator can be driven to the fully open or closed positions (depending on valve type) by connecting SN to terminals 1 or 3.

Manual override

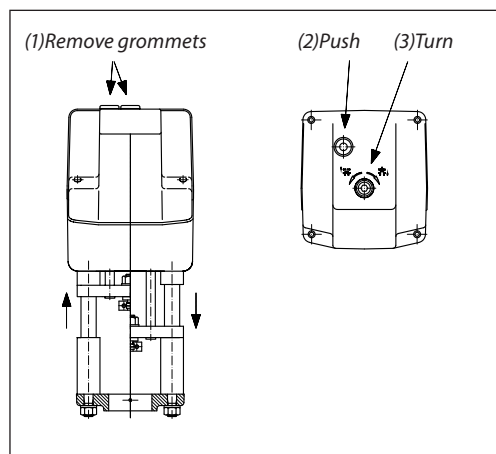

The manual override is applied by rotating the 8 mm Allen key (not supplied) to the required position. Observe the direction of rotation symbol.

- Disconnect power
- Remove grommets and push the button
- Adjust valve position using an 8 mm Allen key
- Set valve to closed position
- Restore power

Note:
Actuator will restore position required by Y signal.

Dimensions

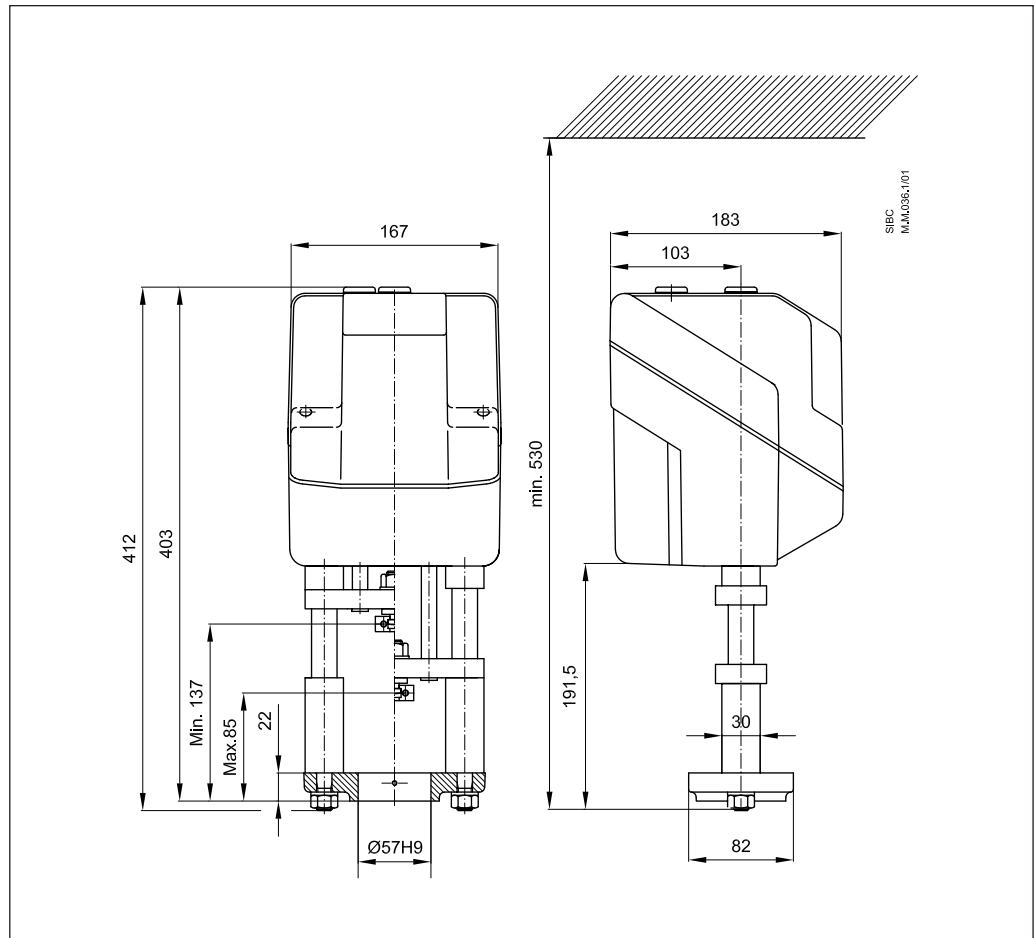

Actuator - valve combinations

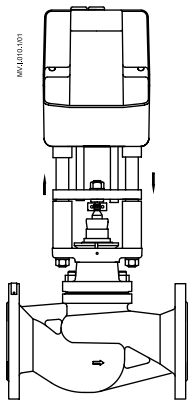

AME 85/86 + VFS 2 (DN 65 - 100)

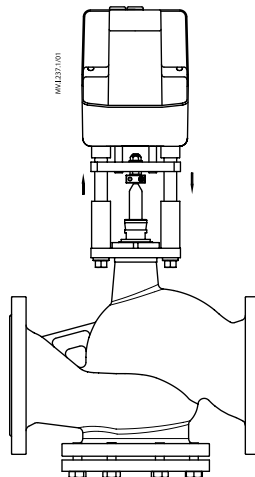

AME 85/86 + VF 2 (DN 125 - 150)
AME 85/86 + VF 3 (DN 125 - 150)

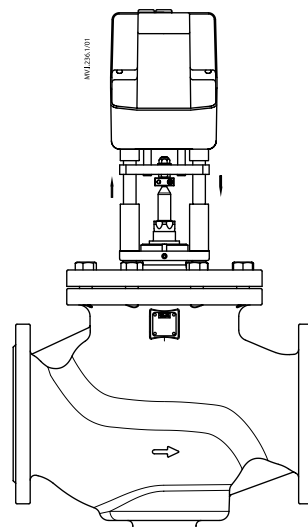

AME 85/86 + VFM 2 (DN 150-250)

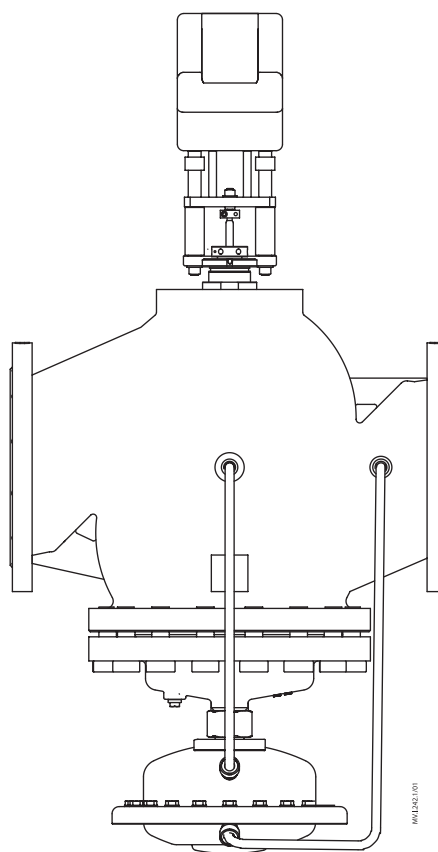

AME 85/86 + AFQM (DN 150 - 250)



Danfoss A/S

Climate Solutions • danfoss.com • +45 7488 2222

Any information, including, but not limited to information on selection of product, its application or use, product design, weight, dimensions, capacity or any other technical data in product manuals, catalogues descriptions, advertisements, etc. and whether made available in writing, orally, electronically, online or via download, shall be considered informative, and is only binding if and to the extent, explicit reference is made in a quotation or order confirmation. Danfoss cannot accept any responsibility for possible errors in catalogues, brochures, videos and other material. Danfoss reserves the right to alter its products without notice. This also applies to products ordered but not delivered provided that such alterations can be made without changes to form, fit or function of the product.

All trademarks in this material are property of Danfoss A/S or Danfoss group companies. Danfoss and the Danfoss logo are trademarks of Danfoss A/S. All rights reserved.