

Fact sheet

Danfoss Digital Hydronics™

Modular hydronic HVAC 4.0 design solution
with AB-QM, NovoCon® and Flow sensor

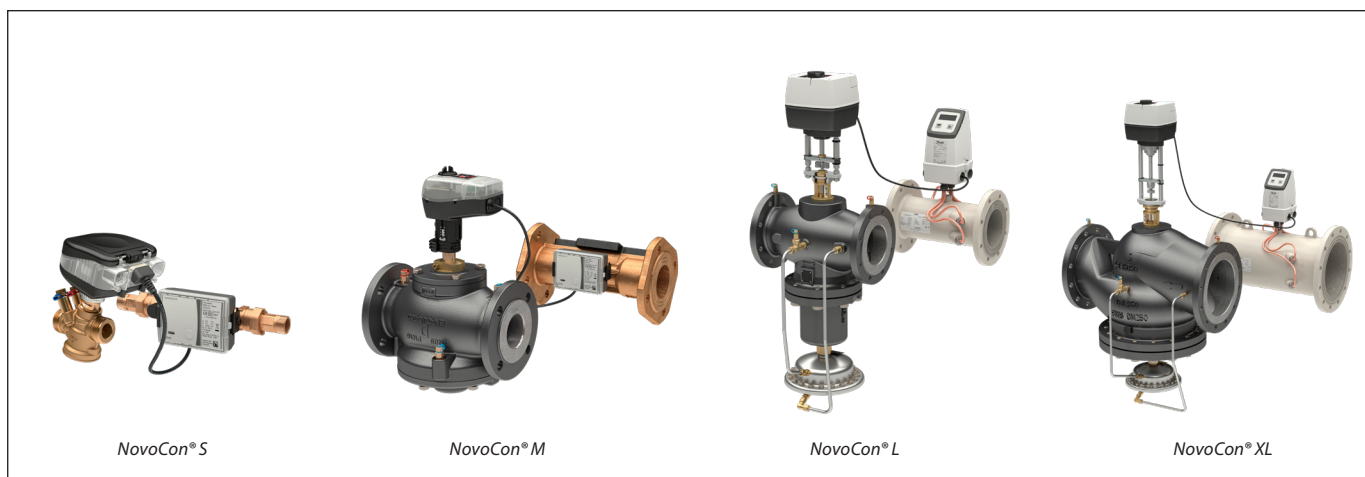



Introduction

Danfoss Digital Hydraulics™ offers you a highly flexible, modular solution for hydronic HVAC 4.0 designs. The digitalization of HVAC systems opens a world of possibilities to increase energy efficiency and user comfort to new levels. To achieve this, it is highly important to establish a dynamic hydronic balance throughout the building. BMS connected digital actuators not only provide highly accurate temperature control, but their data inputs are also essential. Optional temperature and flow data expand the insights and allow continuous energy optimization. Danfoss Digital Hydraulics™ covers all what is needed to establish a fully digital hydronic HVAC system. In this factsheet we describe how the different components in the solution are best combined. This is split into different application needs, based on required design flows.

For e.g. Terminal units up to DN 32, the combination consists of AB-QM (4.0) + NovoCon S + SonoSensor 30
For e.g. Air Handling Units up to DN 100, the combination exists of AB-QM + NovoCon M + SonoSensor 30
For e.g. Chillers and District cooling up to DN 250, the combination exists of AB-QM + NovoCon L/XL + SONO 3500 CT

Table of contents

1. NovoCon® S	3	3. NovoCon® L, XL	17
1.1 Description.....	3	3.1 Description	17
1.2 Ordering.....	3	3.2 Ordering.....	17
1.3 Technical data.....	4	3.3 Technical data.....	18
1.4 I/O points on NovoCon S.....	4	3.4 I/O connections on NovoCon® L, XL.....	18
1.4.1 I/O cables.....	4	3.5 Immersed sensor.....	19
1.5 Temperature sensors.....	5	3.6 SONO 3500 CT.....	19
1.5.1 Immersed sensor.....	5	3.6.1 Description.....	19
1.6 SonoSensor 30.....	6	3.6.2 Technical specifications.....	20
1.6.1 Description.....	6	3.7 Cross reference table.....	20
1.6.2 Technical specifications.....	6	3.8 Commissioning/connection of flow sensor to.....	21
1.7 Cross reference table.....	7	3.9 BACnet and Modbus.....	22
1.8 Commissioning/connection of flow sensor to.....	8	3.9.1 Modbus registers.....	22
1.9 BACnet and Modbus.....	9	3.9.2 BACnet objects.....	23
1.9.1 Modbus registers.....	9		
1.9.2 BACnet objects.....	9		
2. NovoCon® M	11		
2.1 Description	11		
2.2 Ordering.....	11		
2.3 Technical data.....	12		
2.4 I/O connections on NovoCon® M.....	12		
2.5 Immersed sensor.....	12		
2.6 SonoSensor 30.....	13		
2.6.1 Description.....	13		
2.6.2 Technical specifications.....	13		
2.7 Cross reference table	14		
2.8 Commissioning/connection of flow sensor to.....	14		
2.9 BACnet and Modbus.....	15		
2.9.1 Modbus registers.....	15		
2.9.2 BACnet objects.....	16		

1. NovoCon® S
1.1 Description

With latest update on firmware for NovoCon®, flow sensor can be connected to NovoCon® actuator, for precise measurement of flow. NovoCon® S actuator can be used for solutions with sizes from DN15 to DN32.

Flow sensor can be connected on any input on NovoCon®. Danfoss recommends using AI input, so energy features can stay functional.

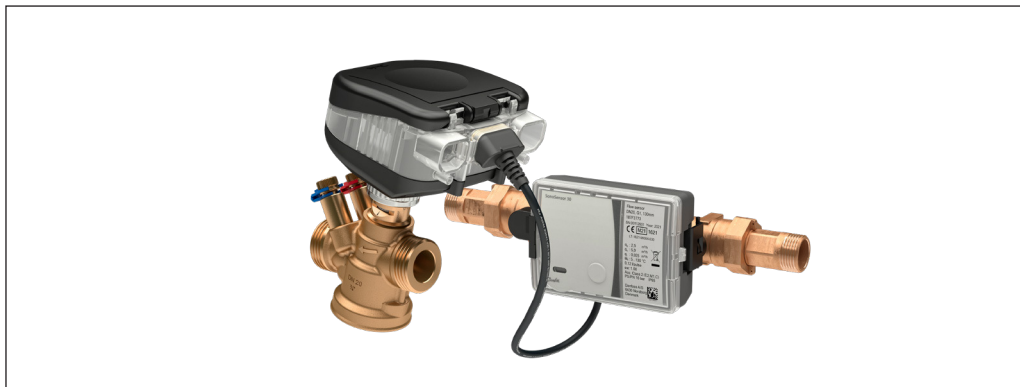
1.2 Ordering
 DN15 - DN32

AB-QM 4.0 threaded version (with test plugs and without test plugs) - External thread

Type				With test plugs	Without test plugs
Picture	DN	Q _{nom.} (l/h)	Ext. thread (ISO 228/1)	Code No.	Code No.
	15 LF	200	G 3/4A	003Z8200	003Z8220
	15	650		003Z8201	003Z8221
	15 HF	1,200		003Z8202	003Z8222
	20	1,100	G 1A	003Z8203	003Z8223
	20 HF	1,900		003Z8204	003Z8224

AB-QM threaded version (with test plugs and without test plugs) - External thread

Type				With test plugs	Without test plugs
Picture	DN	Q _{nom.} (l/h)	Ext. thread (ISO 228/1)	Code No.	Code No.
	25	2,200	G 1 1/4A	003Z8205	-
	25HF	3,800		003Z8206	-
	32	3,600	G 1 1/2A	003Z8207	-
	32 HF	5,000		003Z8208	-

AB-QM 4.0 threaded version (with test plugs and without test plugs) - Internal thread

Type				With test plugs	Without test plugs
Picture	DN	Q _{nom.} (l/h)	Int. thread (ISO 7/1)	Code No.	Code No.
	15 LF	200	Rp 1/2	003Z8300	003Z8320
	15	650		003Z8301	003Z8321
	15 HF	1,200		003Z8302	003Z8322
	20	1,100	Rp 3/4	003Z8303	003Z8323
	20 HF	1,900		003Z8304	003Z8324
	25	2,300	-	003Z8205	-
	25 HF	3,800	-	003Z8206	-
	32	3,600	-	003Z8207	-
	32 HF	5,000	-	003Z8208	-

Temperature sensors

Type	Code No.
Immersed Pt 1000 / Ø 5.2 mm / 1.5 m cable, MID	187F3418
Immersed Pt 1000 / Ø 5.2 mm / 3.0 m cable, MID	187F3419

Accessories

Designation	Code No.
Immersion brass-pockets, 35 mm, Ø 5.2 pair, MID. For pipes DN15-32	087G6053

1.3 Technical data
DN15 - DN32

Power supply range	24 V AC/DC, 50 / 60 Hz *
Power consumption	Operating: 2.7 VA@24VAC / 1.2 W@24VDC Standby: 1.8 VA@24VAC / 0.7 W@24VDC
Protection class	III safety extra-low voltage
Control signal NovoCon® S	BACnet MS/TP, Modbus RTU 0-10 VDC, 0-5 VDC, 2-10 VDC, 5-10 VDC, 2-6 VDC, 6-10 VDC, 0-20 mA, 4-20 mA
Impedance	R_{in} AI:0 >100 k Ω (V); 500 Ω (mA)
	R_{out} AO: 1500 Ω
Actuator speed selections (open to close)	3 sec/mm, 6 sec/mm, 12 sec/mm, 24 sec/mm, Constant Time
Stroke	7 mm
Force	90 N
Position accuracy	\pm 0.05 mm
Ambient temp. range	-10° C to 50° C
Ambient humidity	98% r.h., non-condensing (according to EN 60730-1)
Max. medium temp.	120° C
Storage temp. range	-40 to 70 °C
Grade of enclosure	IP 54 (IP 40 upside down)
Weight	0.4 kg

* NovoCon® S is designed to operate at power deviations up to \pm 25%.

BACnet data

Type	Description
BACnet device profile	BACnet Application Specific Controller (B-ASC)
BACnet protocol	BACnet Master Slave / Token Passing (MS/TP)
BACnet baud rates supported	Auto baud rate detection* / 9600 bps / 19200 bps / 38400 bps / 56700 bps / 76800 bps / 115200bps

Modbus RTU data

Supported baud rates	Auto baud rate detection* / 9600 bps / 19200 bps / 38400 bps / 56700 bps / 76800 bps / 115200bps
Supported transmission modes	Parity: None (1-8-N-2) / Odd (1-8-O-1) / Even (1-8-E-1) / None (1-8-N-1) / Auto parity* Data format: Parity (Start bit - Data bits - Parity - Stop bits)

* Default

1.4 I/O points on NovoCon S

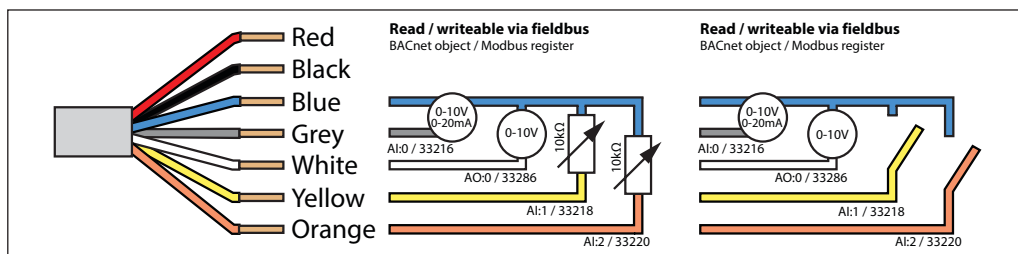

1.4.1 I/O cable (003Z8612) or temperature cable (003Z8613)

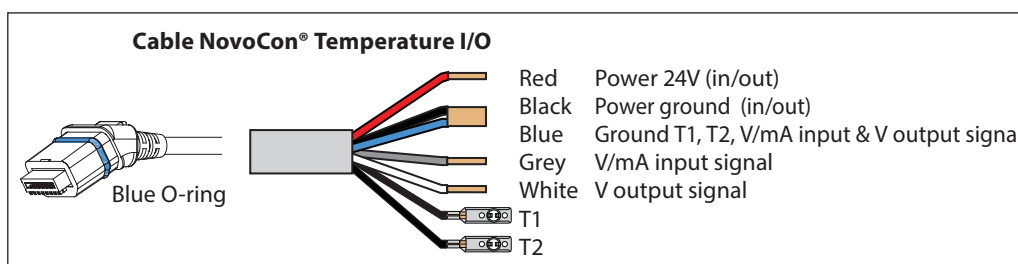
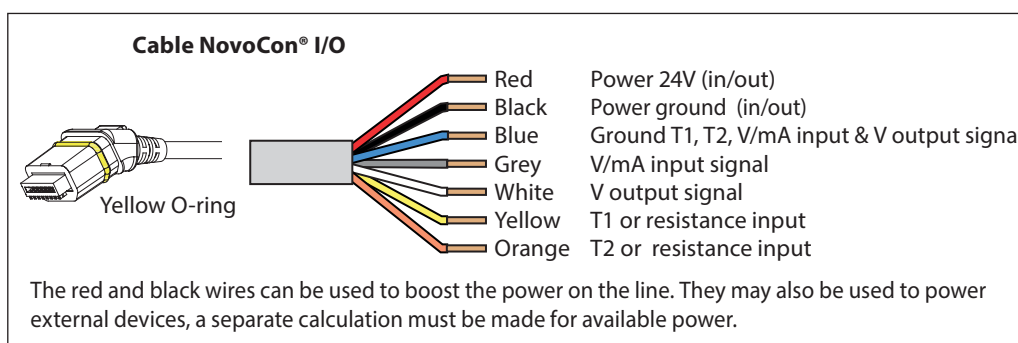

1.5 Temperature sensors

Functional description

The sensor unit consists of a platinum element, the resistance value of which, changes proportionally with the temperature.

Pt 1000 ohm sensor (1000 ohm at 0°C).

The sensor is adjusted and meets the tolerance requirements of EN 60751 Class B.

The accuracy of temperature measurement is approximately 0.5° in typical operating range. It is unlikely, that during calculation of ΔT , deviation of both sensors would be summed up. Therefore, it is estimated that ΔT measurement accuracy is 0.5° when the sensors are mounted correctly.

It is not recommended to use longer wires on temperature sensors than 2m due to risk of electromagnetic interference. If long or thin wires are used it may be necessary to make an offset of the temperature reading in the BMS system.

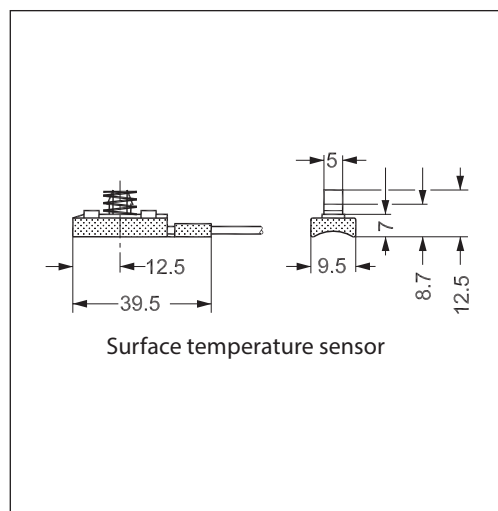

1.5.1 Immersed sensor

Temperature sensors	Installation	Type	Diameter D (mm)	Length L (mm)	Code no.
	Immersed (direct) or in pocket (indirect)	Pt 1000	Ø5.2	45	187F3418

Sensors pockets	Type	Brass	Code no.	
	Sensor diameter	(mm)	087G6053	
	Length	L1 (mm)		47
		L (mm)		35

1.6 SonoSensor 30

1.6.1 Description

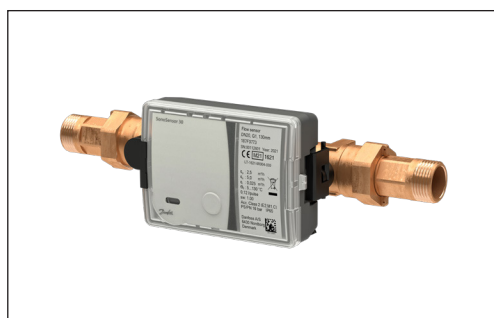

MID examination certificate no.:
LT-1621-MI004-030

SonoSensor 30 is an ultrasonic flow sensor especially designed for heating, cooling or combined heating/cooling application in local and district energy systems. It can be used in conjunction with the type approved heating/cooling energy calculator (e.g. Infocal 9) to form combined heating/cooling energy meter. SonoSensor 30 has been approved according to MID in accuracy class 2. The flow sensor can be mounted in both flow and return pipe.

Features

- Available in nominal flow rates qp 0.6, 1.0, 1.5, 2.5, 3.5, 6.0, 10.0, 15.0, 25.0, 40.0, and 60.0 m³/h
- Housings with thread (G3/4 to G2) or flange (DN20 to DN100) connections
- MID approval for ultrasonic flow sensor with dynamic range of 1:100 (qi:qp) in class 2
- Optional dynamic range of 1:250 in class 2 (with the exceptions of sensors qp 0.6 m³/h, 1.0 m³/h and 3.5 m³/h)
- Temperature range: 5 - 130 °C
- Operating pressure PN 16 or PN 25 bar
- Flow sensor with IP65 protection class and IP67 for heating/cooling application.
- Battery lifetime not less than 12 years
- Low pressure loss, insensitive to dirt
- No inlet or outlet restrictions up to DN50
- Short overload temperature up to 150 °C

1.6.2 Technical specifications

Diameter	DN 15		DN 20				DN25, DN32							
Connection type	G¾		G1				G1¼							
Overall length, mm	110	110; 165	190		130		260							
Flow rate														
Nominal, m3/h	0.6	1.5	0.6	1.5	2.5	1.5	2.5	3.5	6.0					
Maximum, m3/h	1.2	3.0	1.2	3.0	5.0	3.0	5.0	7	12					
Minimum, l/h	6	6	15	6	6	15	10	25	15	10	25	35	24	60
Starting flow rate, l/h	3	3		3	5		5		17		12			
Pressure loss at qp, mbar	70	171	90	58	94	72	198	40	100					
Max. operating pressure	Thread 16 bar Flange 25 bar													
Flow sensor temp. range	5 to 130°C (short overload 150°C)													
Flow sensor to electronic box cable length	1.2m up to DN32 2.5m up to DN40 to DN100													
Medium	Water quality with pH 7 to 9.5													
Volume measuring cycles	1 second													
Supply voltage	3.6V DC Lithium battery (AA-cell)/ Mains supply 24V AC/DC Mains supply 230V AC (with external 230V to 24V AC transformer)													
Battery lifetime	Not less than 12 years													
Approval	EN1434 class 2													
Environmental class	class C													
Ambient class	E2 + M1													
Protection class	IP65 (IP67 for heating/cooling)													
Ambient operating temp.	+5°C to +55°C													
Max. ambient humidity	<93% rel. humidity													

1.7 Cross reference table AB-QM – Flow sensor - NovoCon® S:

Valve code	Valve name	Valve connection	Actuator code	Actuator name	Flow sensor code	Flow sensor name	Flow sensor connection	NovoCon S cable	Temperature sensor code (PT1000)	Temperature pockets code
003Z8220	AB-QM4 DN15 LF 0.2 m3/h	thread	003Z8504	NovoCon® S	187F3771	SonoS30 DN15 Qp 0.6 m3/h	thread	003Z8613*	/	/
								003Z8612	187F3418	087G6053
003Z8221	A-BQM4 DN15 0.65 m3/h	thread	003Z8504	NovoCon® S	187F3771	SonoS30 DN15 Qp 0.6 m3/h	thread	003Z8613*	/	/
								003Z8612	187F3418	087G6053
003Z8222	AB-QM4 DN15 HF 1.2 m3/h	thread	003Z8504	NovoCon® S	187F3772	SonoS30 DN15 Qp 1.5 m3/h	thread	003Z8613*	/	/
								003Z8612	187F3418	087G6053
003Z8223	AB-QM4 DN20 1.1 m3/h	thread	003Z8504	NovoCon® S	187F3772	SonoS30 DN15 Qp 1.5 m3/h	thread	003Z8613*	/	/
								003Z8612	187F3418	087G6053
003Z8224	AB-QM4 DN20 HF 1.9 m3/h	thread	003Z8504	NovoCon® S	187F3772	SonoS30 DN15 Qp 1.5 m3/h	thread	003Z8613*	/	/
								003Z8612	187F3418	087G6053
003Z8320	AB-QM4 DN15 LF 0.2 m3/h	int. thread	003Z8504	NovoCon® S	187F3771	SonoS30 DN15 Qp 0.6 m3/h	thread	003Z8613*	/	/
								003Z8612	187F3418	087G6053
003Z8321	AB-QM4 DN15 0.65 m3/h	int. thread	003Z8504	NovoCon® S	187F3771	SonoS30 DN15 Qp 0.6 m3/h	thread	003Z8613*	/	/
								003Z8612	187F3418	087G6053
003Z8322	AB-QM4 DN15 HF 1.2 m3/h	int. thread	003Z8504	NovoCon® S	187F3772	SonoS30 DN15 Qp 1.5 m3/h	thread	003Z8613*	/	/
								003Z8612	187F3418	087G6053
003Z8323	AB-QM4 DN20 1.1 m3/h	int. thread	003Z8504	NovoCon® S	187F3772	SonoS30 DN15 Qp 1.5 m3/h	thread	003Z8613*	/	/
								003Z8612	187F3418	087G6053
003Z8324	AB-QM4 DN20 HF 1.9 m3/h	int. thread	003Z8504	NovoCon® S	187F3772	SonoS30 DN15 Qp 1.5 m3/h	thread	003Z8613*	/	/
								003Z8612	187F3418	087G6053
003Z1204	AB-QM DN25 1.7 m3/h	thread	003Z8504	NovoCon® S	187F3773	SonoS30 DN20 Qp 2.5 m3/h	thread	003Z8613*	/	/
								003Z8612	187F3418	087G6053
003Z1224	AB-QM DN25 HF 2.7 m3/h	thread	003Z8504	NovoCon® S	187F3773	SonoS30 DN20 Qp 2.5 m3/h	thread	003Z8613*	/	/
								003Z8612	187F3418	087G6053
003Z1205	AB-QM DN32 3.2 m3/h	thread	003Z8504	NovoCon® S	187F3774	SonoS30 DN25 Qp 3.5 m3/h	thread	003Z8613*	/	/
								003Z8612	187F3418	087G6053
003Z1225	AB-QM DN32 HF 4.0 m3/h	thread	003Z8504	NovoCon® S	187F3774	SonoS30 DN25 Qp 3.5 m3/h	thread	003Z8613*	/	/
								003Z8612	187F3418	087G6053

* IO cable with surface sensor (PT1000)

**1.8 Commissioning/
connection of flow sensor to:
NovoCon® S**

NovoCon® S supports connection of flow sensor directly to NovoCon® IO cable. Flow sensor must be connected to AI and AO terminal. NovoCon must be set to digital mode (MSV:9/32810 = 2), output functionality set to Inactive (BV:3/32817 = 0) and value of output (AO:0/33286 = 10) on 10 V. You also need to select AI (MSV: 41/32821) input for connecting flow sensor.

To get right flow sensor value it is very important to set right value of liters per pulse on NovoCon® (AV: 43/32864). Usually this is written on flow sensor specification sheet. If we would like to use flow sensor for calculating energy we must also change register MSV12/32814*.

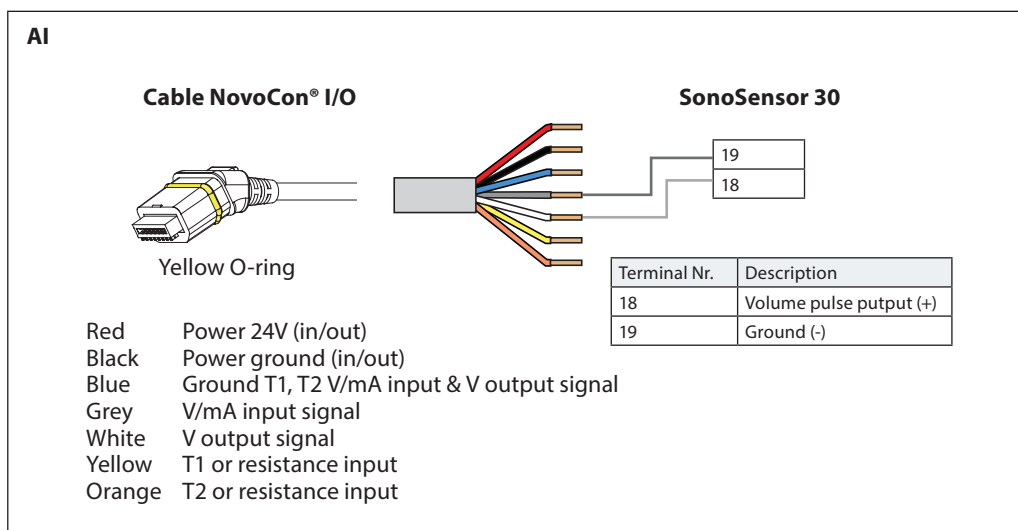

Object/Register	Write/read value	Description
MSV:9 / 32810	2: Digital mode	Application mode
BV:3 / 32817	0: Inactive	Output feedback
AO:0 / 33286	10	Value on output
MSV:41 / 32821	3: Flow sensor	AI input
AV:43 / 32864	0,04 (depends on flow sensor)	Pulse volume (liter/pulse)
MSV:12 / 32814	3: ON, flow sensor on return pipe	Energy counting method*

*Energy counting method

MSV: 12 / 32814

State 1: Off

NovoCon® S is not calculating energy.

State 2: On, indicated flow

NovoCon® S is calculating energy based on temperature difference between T1 and T2 and using indicated flow.

State 3: On, flow sensor on return pipe

NovoCon® S is calculating energy based on temperature difference between T1 and T2 and using flow from flow sensor installed on return pipe.

State 4: On, flow sensor on supply pipe

NovoCon® S is calculating energy based on temperature difference between T1 and T2 and using flow from flow sensor installed on supply pipe.

1.9 BACnet and Modbus

1.9.1 Modbus registers

Configuration

Modbus register	Read/Write	Modbus function	Modbus Data Type	Object / Parameter name	Description	Default State	Description of usage	Persistent Yes/No
0x802E 32814	R/W	3, 4 & 6	WORD	Energy counting method	1: Off 2: On, indicated flow 3: On, flow sensor on return pipe 4: On, flow sensor on supply pipe	1: Off	State 1: Off NovoCon® is not calculating energy. State 2: On, indicated flow NovoCon® is calculating energy based on temperature difference between T1 and T2 and using indicated flow. State 3: On, flow sensor on return pipe NovoCon® is calculating energy based on temperature difference between T1 and T2 and using flow from flow sensor installed on return pipe. State 4: On, flow sensor on supply pipe NovoCon® is calculating energy based on temperature difference between T1 and T2 and using flow from flow sensor installed on supply pipe.	Yes

Configuration #2

Modbus register	Read/Write	Modbus function	Modbus Data Type	Object / Parameter name	Description	Default State	Unit	Description of usage	Persistent Yes/No
0x8033 32819	R/W	3, 4 & 6	WORD	T1, T2 temperature sensor type	Select the type of Temperature sensor connected for T1 and T2.	3: PT1000	na	Select temperature sensor type: 1: NTC10k Type 2 2: NTC10k Type 3 3: PT1000	Yes
0x8035 32821	R/W	3, 4 & 6	WORD	AI input	Different options for analog input terminal	2: Analog input	na	1: Disabled 2: Analog input (voltage/current) 3: Flow sensor	Yes
0x8036 32822	R/W	3, 4 & 6	WORD	T1 input	Different options for T1 terminal	2: Supply temp.	na	1: Disabled 2: Supply temperature 3: Return temperature 4: Flow sensor	Yes
0x8037 32823	R/W	3, 4 & 6	WORD	T2 input	Different options for T2 terminal	3: Return temp.	na	1: Disabled 2: Supply temperature 3: Return temperature 4: Flow sensor	Yes
0x8060 32864	R/W	3, 4 & 16	FLOAT	Pulse volume	Pulse volume of connected flow sensor	0,4 l/p	Litre/pulse	Adapts automatically to the selected AB-QM valve, but can be overwritten manually. If set to 0 NovoCon only count pulses and do not perform flow measurements based on received pulses. This can be used to connect e.g. water meter or energy meter.	Yes

Operating

Modbus register	Read/Write	Modbus function	Modbus Data Type	Object / Parameter name	Description	Default State	Unit	Description of usage	Persistent Yes/No
0x8210 33296	R	3, 4	FLOAT	Volume counter	Total accumulated water volume	0	L	Total accumulated water volume passed through the valve, combined from both heating and cooling	Yes
0x8212 33298	R	3, 4	FLOAT	Pulse counter	Total accumulated number of pulses	0	pulse	Total accumulated number of pulses received from flow sensor	Yes

Alarms & warning

Modbus register	Read/Write	Modbus function	Modbus Data Type	Object / Parameter name	Description	Default State	Description of usage	Persistent Yes/No
0x8300 33536	R	3, 4	FLOAT	Warning: Flow out of expectations	Warning for lower or higher flow than expected	0: OFF	Bit 25 0: OFF 1: ON	No
				Warning: No flow detected	Flow sensor does not recognize any flow, through flow sensor	0: OFF	Bit 26 0: OFF 1: ON	No

1.9.2 BACnet Objects - Multi State Value

Ident	Object / Parameter name	Read/Write	State Text	Default State	Description	Persistent Yes/No
MSV:12	Energy counting method	R/W	1: Off 2: On, indicated flow 3: On, flow sensor on return pipe 4: On, flow sensor on supply pipe	1: Off	State 1: Off NovoCon® is not calculating energy. State 2: On, indicated flow NovoCon® is calculating energy based on temperature difference between T1 and T2 and using indicated flow. State 3: On, flow sensor on return pipe NovoCon® is calculating energy based on temperature difference between T1 and T2 and using flow from flow sensor installed on return pipe. State 4: On, flow sensor on supply pipe NovoCon® is calculating energy based on temperature difference between T1 and T2 and using flow from flow sensor installed on supply pipe.	Yes
MSV:14**	T1, T2 temperature sensor type	R/W	Select temperature sensor type: 1: NTC10k Type 2 2: NTC10k Type 3 3: PT1000 4: PT500 5: PT100	3: PT1000	Select the type of Temperature sensor connected for T1 and T2.	Yes
MSV: 41	AI input	R/W	1: Disabled 2: Analog input (voltage/current) 3: Flow sensor (pulse counter)	2: Analog input	Different options for analog input terminal	Yes
MSV: 42	T1 input	R/W	1: Disabled 2: Supply temperature 3: Return temperature 4: Flow sensor	2: Supply temp.	Different options for T1 terminal If MSV:24 or MSV:25 or MSV:26 is on value 3, then value is for resistance, not temperature.	Yes
MSV: 43	T2 input	R/W	1: Disabled 2: Supply temperature 3: Return temperature 4: Flow sensor	3: Return temp.	Different options for T2 terminal If MSV:24 or MSV:25 or MSV:26 is on value 3, then value is for resistance, not temperature.	Yes

** Only for NovoCon M, L/XL

BACnet Objects - Analog Value

Ident	Object / Parameter name	Unit	Read/ Write	Min	Max	Default State	Resolution	Description	Persistent Yes/No
AV:27	Alarm summary count	No units	R	na	na	0	na	Numerical overview about pending errors detected. Coding for AV:27 Alarm summary count is: If BV:10 is active then AV:27 is 1.0. If BV:11 is active then AV:27 is 2.0. If BV:12 is active then AV:27 is 4.0. If BV:13 is active then AV:27 is 8.0. If BV:14 is active then AV:27 is 16.0. If BV:15 is active then AV:27 is 32.0. If BV:16 is active then AV:27 is 64.0. If BV:17 is active then AV:27 is 128.0. If BV:18 is active then AV:27 is 256.0. If BV:19 is active then AV:27 is 512.0. If BV:20 is active then AV:27 is 1024.0. If BV:21 is active then AV:27 is 2048.0. If BV:22 is active then AV:27 is 4096.0. If BV:23 is active then AV:27 is 8192.0. If BV:24 is active then AV:27 is 16384.0. If BV:25 is active then AV:27 is 32768.0. If BV:26 is active then AV:27 is 65536.0. e.g. if both BV:11 & BV:12 are active then AV:27 is 6.0. This object is supported by COV	No

Ident	Object / Parameter name	Unit	Read/ Write	Min	Max	Default State	Description	Information	Persistent Yes/No
AV: 43	Pulse volume	Litre/pulse (l/p)	R/W	0	na	0	Pulse volume of connected flow sensor	Adapts automatically to the selected AB-QM valve, but can be overwritten manually. If set to 0 NovoCon only count pulses and do not perform flow measurements based on received pulses. This can be used to connect e.g. water meter or energy meter.	Yes
AV: 44	Volume counter	m ³	R	0	na	0	Total accumulated water volume	Total accumulated water volume passed through the valve, combined from both heating and cooling	Yes
AV: 45	Pulse counter	pulse	R	0	na	0	Total accumulated number of pulses	Total accumulated number of pulses received from flow sensor	Yes

BACnet Objects - Binary Value

Ident	Object / Parameter name	Read/ Write	Active Text (1)	Inactive Text (0)	Default State	Description	Persistent Yes/No
BV: 25	Warning: Flow out of expectations	R	ON	OFF	na	Warning for lower or higher flow than expected	No
BV: 26	Warning: No flow detected	R	ON	OFF	na	No flow detected with flow sensor	No

2. NovoCon® M

2.1 Description

With latest update on firmware for NovoCon®, flow sensor can be connected to NovoCon® actuator, for precise measurement of flow.

NovoCon® M actuator can be used for solutions with sizes from DN40 to DN100.

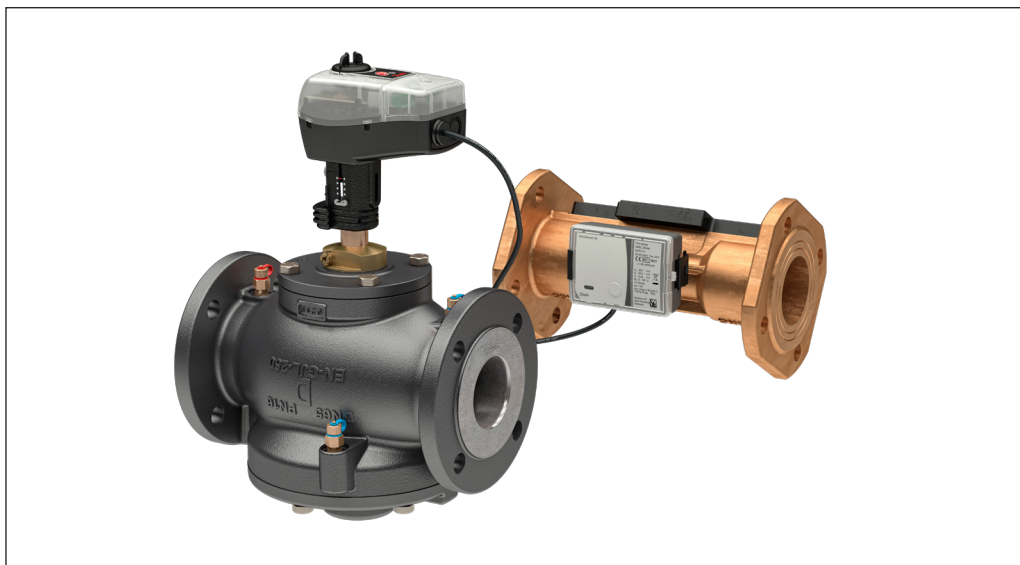

2.2 Ordering
DN40 - DN100

AB-QM threaded version (with test plugs and without test plugs) - External thread

Type				With test plugs	Without test plugs
Picture	DN	Q _{nom.} (l/h)	Ext. thread (ISO 228/1)	Code No.	Code No.
	40	7,500	G 2 A	003Z1770	*
	50	12,500	G 2 ½ A	003Z1771	

* AB-QM DN 15-32 w/o TP can not be upgraded to version with TP

AB-QM flanged version

Picture	DN	Q _{nom.} (l/h)	Flange connection (EN 1092-1)	Code No.
	50	12,500	PN 16	003Z1772
	65	20,000		003Z1773
	65 HF	25,000		003Z1793
	80	28,000		003Z1774
	80 HF	40,000		003Z1794
	100	38,000		003Z1775
	100 HF	59,000		003Z1795

Temperature sensors

Type	Code No.
Immersed Pt 1000 / Ø 5.2 mm / 1.5 m cable, MID	187F3418
Immersed Pt 1000 / Ø 5.2 mm / 3.0 m cable, MID	187F3419

Accessories

Designation	Code No.
Immersion brass-pockets, 52 mm, Ø 5.2 pair, MID. For pipes DN40-65	087G6054
Immersion brass-pockets, 85 mm, Ø 5.2 pair, MID. For pipes DN80-125	087G6055

2.3 Technical data

NovoCon® M

Power supply	V	24 ±25% ac/dc
Power consumption	running	VA <3.5@24Vac / <2.0@24Vdc
	standby	W 2.0 ac / 0.9 dc
Frequency	Hz	50/60±10%
Control signal	VDC	BACnet MS/TP, Modbus RTU, 0-10, 0-5, 2-10, 5-10, 2-6, 6-10
	mA	0-20, 4-20
Impedance		Rin 90kΩ (V), 500 Ω (mA)
		Rout 250Ω
Closing force	N	550
Max. stroke	mm	20
Position accuracy	mm	± 0.2
Actuator speed selections (open to close)	s/mm	3, 6, 12, 24, Constant Time
Max. medium temperature		120
Ambient temperature	°C	-10 ... 50
Storage and transport temperature		-40 ... 70
Ambient humidity		5-95% r.h., non-condensing (according to EN 60730-1)
Protection class		III
Grade of enclosure		IP 54
Weight	kg	0.5

**2.4 I/O connections
NovoCon® M**

With latest update on firmware for NovoCon®, flow sensor can be connected to NovoCon® actuator, for precise measurement of flow.

NovoCon® M actuator can be used for solutions with sizes from DN40 to DN100.

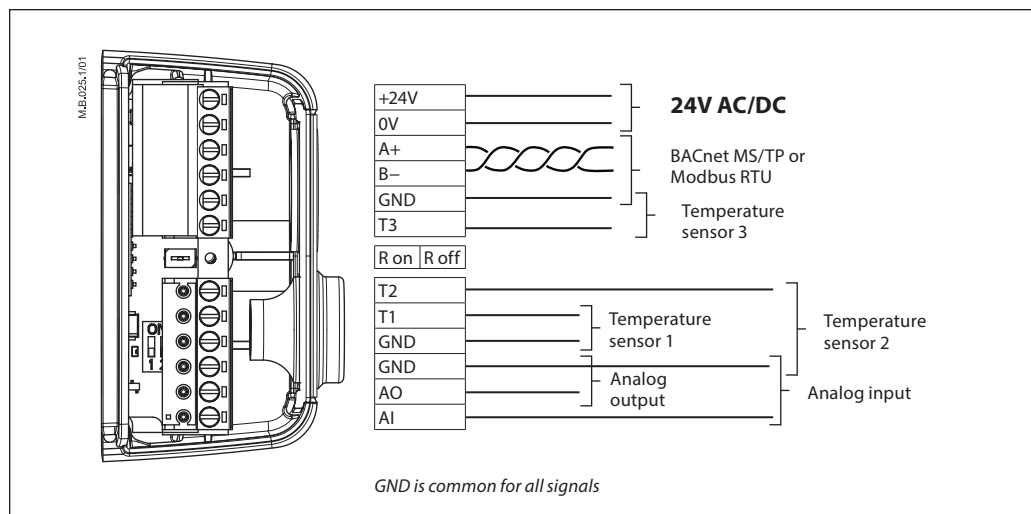

2.5 Immersed sensor

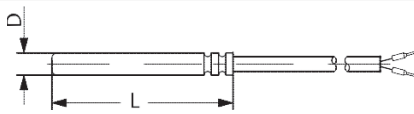
Temperature sensors	Installation	Type	Diameter D (mm)	Length L (mm)
	Immersed (direct) or in pocket (indirect)	Pt 1000	Ø5.2	45

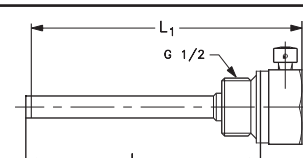
Sensors pockets	Type	Brass	
	Sensor diameter	(mm)	Ø 5.2
	Length	L1 (mm)	60
L (mm)		52	85

2.6 SonoSensor 30

2.6.1 Description

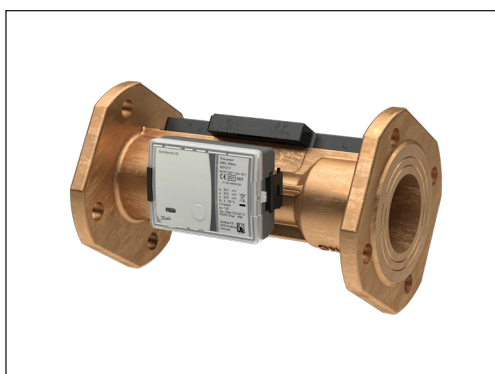

Features

- Available in nominal flow rates qp 0.6, 1.0, 1.5, 2.5, 3.5, 6.0, 10.0, 15.0, 25.0, 40.0, and 60.0 m³/h
- Housings with thread (G3/4 to G2) or flange (DN20 to DN100) connections
- MID approval for ultrasonic flow sensor with dynamic range of 1:100 (qi:qp) in class 2
- Optional dynamic range of 1:250 in class 2 (with the exceptions of sensors qp 0.6 m³/h, 1.0 m³/h and 3.5 m³/h)
- Temperature range: 5 - 130 °C
- Operating pressure PN 16 or PN 25 bar
- Flow sensor with IP65 protection class and IP67 for heating/cooling application.
- Battery lifetime not less than 12 years
- Low pressure loss, insensitive to dirt
- No inlet or outlet restrictions up to DN50
- Short overload temperature up to 150 °C

MID examination certificate no.:
LT-1621-MI004-030

SonoSensor 30 is an ultrasonic flow sensor especially designed for heating, cooling or combined heating/cooling application in local and district energy systems. It can be used in conjunction with the type approved heating/cooling energy calculator (e.g. Infocal 9) to form combined heating/cooling energy meter.

SonoSensor 30 has been approved according to MID in accuracy class 2. The flow sensor can be mounted in both flow and return pipe.

2.6.2 Technical specifications

Diameter	DN40	DN 50	DN 65	DN 80	DN 100
Connection type	G2	FL	FL	FL	FL
Overall length, mm	300	270	300	300	360
Flow rate					
Nominal, m ³ /h	10	15	25	40	60
Maximum, m ³ /h	20	30	50	80	120
Minimum, l/h	40	100	60	150	25
Starting flow rate, l/h	20	30	120	200	300
Pressure loss at qp, mbar	180	120	200	180	180
Max. operating pressure	25 bar				
Flow sensor temp. range	5 to 130°C (short overload 150°C)				
Flow sensor to electronic box cable length	1.2m up to DN32 2.5m up to DN40 to DN100				
Medium	Water quality with pH 7 to 9.5				
Volume measuring cycles	1 second				
Supply voltage	3.6V DC Lithium battery (AA-cell)/ Mains supply 24V AC/DC Mains supply 230V AC (with external 230V to 24V AC transformer)				
Battery lifetime	Not less than 12 years				
Approval	EN1434 class 2				
Environmental class	class C				
Ambient class	E2 + M1				
Protection class	65 (IP67 for heating/cooling)				
Ambient operating temp.	+5°C to +55°C				
Max. ambient humidity	<93% rel. humidity				

2.7 Cross reference table AB-QM - NovoCon®M - Flow sensor:

Valve code	Valve name	Valve connection	Actuator code	Actuator name	Flowmeter code	Flowmeter name	Flowmeter connection	NovoCon S cable	Temperature sensor code (PT1000)	Temperature pockets code
003Z1770	AB-QM NovoCon DN40 7.5 m3/h	thread	003Z8540	NovoCon M	187F3776	SonoS30 DN40 Qp 10.0 m3/h	thread	/	187F3418	087G6054
003Z1771	AB-QM NovoCon DN50 12.5 m3/h	thread	003Z8540	NovoCon M	187F3776	SonoS30 DN40 Qp 10.0 m3/h	thread	/	187F3418	087G6054
003Z1773	AB-QM NovoCon DN65 20.0 m3/h	flange	003Z8540	NovoCon M	187F3777	SonoS30 DN50 Qp 15.0 m3/h	flange	/	187F3419	087G6054
003Z1793	AB-QM NovoCon DN65 HF 25.0 m3/h	flange	003Z8540	NovoCon M	187F3778	SonoS30 DN65 Qp 25.0 m3/h	flange	/	187F3419	087G6054
003Z1774	AB-QM NovoCon DN80 28.0 m3/h	flange	003Z8540	NovoCon M	187F3778	SonoS30 DN65 Qp 25.0 m3/h	flange	/	187F3419	087G6055
003Z1794	AB-QM NovoCon DN80 HF 40.0 m3/h	flange	003Z8540	NovoCon M	187F3779	SonoS30 DN80 Qp 40.0 m3/h	flange	/	187F3419	087G6055
003Z1775	AB-QM NovoCon DN100 38.0 m3/h	flange	003Z8540	NovoCon M	187F3779	SonoS30 DN80 Qp 40.0 m3/h	flange	/	187F3419	087G6055
003Z1795	AB-QM NovoCon DN100 HF 59.0 m3/h	flange	003Z8540	NovoCon M	187F3780	SonoS30 DN100 Qp 60.0 m3/h	flange	/	187F3419	087G6055

2.8 Commissioning/wiring

NovoCon® M supports connection of flow sensor directly to NovoCon® inputs. Flow sensor must be connected to T3 and GND terminal. NovoCon must be set to digital mode (MSV:9/32810 = 2). You also need to select T3 (MSV: 44/32821) input for connecting flow sensor.

To get right flow sensor value it is very important to set right value of liters per pulse on NovoCon® (AV: 43/32864). Usually this is written on flow sensor specification sheet. If we would like to use flow sensor for calculating energy we must also change register MSV12/32814*.

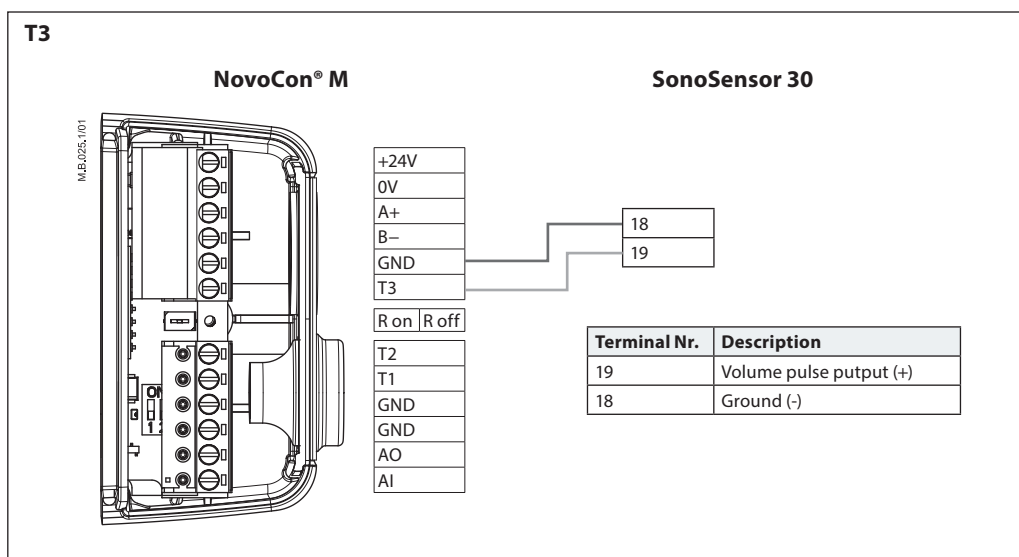

Object/Register	Write/read value	Description
MSV:44 / 32824	3: Flow sensor	T3 input
AV:43 / 32864	0,04 (depends on flow sensor)	Pulse volume (liter/pulse)
MSV:12 / 32814	3: ON, flow sensor on return pipe	Energy counting method*

*Energy counting method

MSV: 12 / 32814

State 1: Off

NovoCon® M is not calculating energy.

State 2: On, indicated flow

NovoCon® M is calculating energy based on temperature difference between T1 and T2 and using indicated flow.

State 3: On, flow sensor on return pipe

NovoCon® M is calculating energy based on temperature difference between T1 and T2 and using flow from flow sensor installed on return pipe.

State 4: On, flow sensor on supply pipe

NovoCon® M is calculating energy based on temperature difference between T1 and T2 and using flow from flow sensor installed on supply pipe.

2.9 BACnet and Modbus

2.9.1 Modbus registers

Configuration

Modbus register	Read/Write	Modbus function	Modbus Data Type	Object / Parameter name	Description	Default State	Description of usage	Persistent Yes/No
0x802E 32814	R/W	3,4 & 6	WORD	Energy counting method	1: Off 2: On, indicated flow 3: On, flow sensor on return pipe 4: On, flow sensor on supply pipe	1: Off	State 1: Off NovoCon® is not calculating energy. State 2: On, indicated flow NovoCon® is calculating energy based on temperature difference between T1 and T2 and using indicated flow. State 3: On, flow sensor on return pipe NovoCon® is calculating energy based on temperature difference between T1 and T2 and using flow from flow sensor installed on return pipe. State 4: On, flow sensor on supply pipe NovoCon® is calculating energy based on temperature difference between T1 and T2 and using flow from flow sensor installed on supply pipe.	Yes

Configuration #2

Modbus register	Read/Write	Modbus function	Modbus Data Type	Object / Parameter name	Description	Default State	Unit	Description of usage	Persistent Yes/No
0x8033 32819	R/W	3,4 & 6	WORD	T1, T2 temperature sensor type	Select the type of Temperature sensor connected for T1 and T2.	3: PT1000	na	Select temperature sensor type: 1: NTC10k Type 2 2: NTC10k Type 3 3: PT1000	Yes
0x8034 32820**	R/W	3,4 & 6	WORD	T3 temperature sensor type	Select the type of Temperature sensor connected for T3.	3: PT1000	na	Select temperature sensor type: 1: NTC10k Type 2 2: NTC10k Type 3 3: PT1000 4: PT500 5: PT100	Yes
0x8035 32821	R/W	3,4 & 6	WORD	AI input	Different options for analog input terminal	2: Analog input	na	1: Disabled 2: Analog input (voltage/current) 3: Flow sensor	Yes
0x8036 32822	R/W	3,4 & 6	WORD	T1 input	Different options for T1 terminal	2: Supply temp.	na	1: Disabled 2: Supply temperature 3: Return temperature 4: Flow sensor	Yes
0x8037 32823	R/W	3,4 & 6	WORD	T2 input	Different options for T2 terminal	3: Return temp.	na	1: Disabled 2: Supply temperature 3: Return temperature 4: Flow sensor	Yes
0x8038 32824**	R/W	3,4 & 6	WORD	T3 input	Different options for T3 terminal	2: Control temp.	na	1: Disabled 2: Control temperature sensor 3: Flow sensor	Yes
0x8060 32864	R/W	3,4 & 16	FLOAT	Pulse volume	Pulse volume of connected flow sensor	0,4 l/p	Litre/pulse	Adapts automatically to the selected AB-QM valve, but can be overwritten manually. If set to 0 NovoCon only count pulses and do not perform flow measurements based on received pulses. This can be used to connect e.g. water meter or energy meter.	Yes

** Only for NovoCon M, L/XL

Operating

Modbus register	Read/Write	Modbus function	Modbus Data Type	Object / Parameter name	Description	Default State	Unit	Description of usage	Persistent Yes/No
0x8210 33296	R	3,4	FLOAT	Volume counter	Total accumulated water volume	0	L	Total accumulated water volume passed through the valve, combined from both heating and cooling	Yes
0x8212 33298	R	3,4	FLOAT	Pulse counter	Total accumulated number of pulses	0	pulse	Total accumulated number of pulses received from flow sensor	Yes

Alarms & warning

Modbus register	Read/Write	Modbus function	Modbus Data Type	Object / Parameter name	Description	Default State	Description of usage	Persistent Yes/No
0x8300 33536	R	3,4	FLOAT	Warning: Flow out of expectations	Warning for lower or higher flow than expected	0: OFF	Bit 25 0: OFF 1: ON	No
				Warning: No flow detected	Flow sensor does not recognize any flow, through flow sensor	0: OFF	Bit 26 0: OFF 1: ON	No

2.9.2 BACnet Objects - Multi State Value

Ident	Object / Parameter name	Read/Write	State Text	Default State	Description	Persistent Yes/No
MSV:12	Energy counting method	R/W	1: Off 2: On, indicated flow 3: On, flow sensor on return pipe 4: On, flow sensor on supply pipe	1: Off	State 1: Off NovoCon® is not calculating energy. State 2: On, indicated flow NovoCon® is calculating energy based on temperature difference between T1 and T2 and using indicated flow. State 3: On, flow sensor on return pipe NovoCon® is calculating energy based on temperature difference between T1 and T2 and using flow from flow sensor installed on return pipe. State 4: On, flow sensor on supply pipe NovoCon® is calculating energy based on temperature difference between T1 and T2 and using flow from flow sensor installed on supply pipe.	Yes
MSV:14**	T1, T2 temperature sensor type	R/W	Select temperature sensor type: 1: NTC10k Type 2 2: NTC10k Type 3 3: PT1000 4: PT500 5: PT100	3: PT1000	Select the type of Temperature sensor connected for T1 and T2.	Yes
MSV:15**	T3 temperature sensor type	R/W	Select temperature sensor type: 1: NTC10k Type 2 2: NTC10k Type 3 3: PT1000 4: PT500 5: PT100	3: PT1000	Select the type of Temperature sensor connected for T3	Yes
MSV: 41	AI input	R/W	1: Disabled 2: Analog input (voltage/current) 3: Flow sensor (pulse counter)	2: Analog input	Different options for analog input terminal	Yes
MSV: 42	T1 input	R/W	1: Disabled 2: Supply temperature 3: Return temperature 4: Flow sensor	2: Supply temp.	Different options for T1 terminal If MSV:24 or MSV:25 or MSV:26 is on value 3, then value is for resistance, not temperature.	Yes
MSV: 43	T2 input	R/W	1: Disabled 2: Supply temperature 3: Return temperature 4: Flow sensor	3: Return temp.	Different options for T2 terminal If MSV:24 or MSV:25 or MSV:26 is on value 3, then value is for resistance, not temperature.	Yes
MSV: 44**	T3 input	R/W	1: Disabled 2: Control temperature 3: Flow sensor	2: Control temp.	Different options for T3 terminal If MSV:24 or MSV:25 or MSV:26 is on value 3, then value is for resistance, not temperature.	Yes

** Only for NovoCon M, L/XL

BACnet Objects - Analog Value

Ident	Object / Parameter name	Unit	Read/Write	Min	Max	Default State	Resolution	Description	Persistent Yes/No
AV:27	Alarm summary count	No units	R	na	na	0	na	Numerical overview about pending errors detected. Coding for AV:27 Alarm summary count is: If BV:10 is active then AV:27 is 1.0. If BV:11 is active then AV:27 is 2.0. If BV:12 is active then AV:27 is 4.0. If BV:13 is active then AV:27 is 8.0. If BV:14 is active then AV:27 is 16.0. If BV:15 is active then AV:27 is 32.0. If BV:16 is active then AV:27 is 64.0. If BV:17 is active then AV:27 is 128.0. If BV:18 is active then AV:27 is 256.0. If BV:19 is active then AV:27 is 512.0. If BV:20 is active then AV:27 is 1024.0. If BV:21 is active then AV:27 is 2048.0. If BV:22 is active then AV:27 is 4096.0. If BV:23 is active then AV:27 is 8192.0. If BV:24 is active then AV:27 is 16384.0. If BV:25 is active then AV:27 is 32768.0. If BV:26 is active then AV:27 is 65536.0. e.g. if both BV:11 & BV:12 are active then AV:27 is 6.0. This object is supported by COV	No

Ident	Object / Parameter name	Unit	Read/Write	Min	Max	Default State	Description	Information	Persistent Yes/No
AV: 43	Pulse volume	Litre/pulse (l/p)	R/W	0	na	0	Pulse volume of connected flow sensor	Adapts automatically to the selected AB-QM valve, but can be overwritten manually. If set to 0 NovoCon only count pulses and do not perform flow measurements based on received pulses. This can be used to connect e.g. water meter or energy meter.	Yes
AV: 44	Volume counter	m ³	R	0	na	0	Total accumulated water volume	Total accumulated water volume passed through the valve, combined from both heating and cooling	Yes
AV: 45	Pulse counter	pulse	R	0	na	0	Total accumulated number of pulses	Total accumulated number of pulses received from flow sensor	Yes

BACnet Objects - Binary Value

Ident	Object / Parameter name	Read/Write	Active Text (1)	Inactive Text (0)	Default State	Description	Persistent Yes/No
BV: 25	Warning: Flow out of expectations	R	ON	OFF	na	Warning for lower or higher flow than expected	No
BV: 26	Warning: No flow detected	R	ON	OFF	na	No flow detected with flow sensor	No

3. NovoCon® L/XL

3.1 Description

With latest update on firmware for NovoCon® L/ XL, flow sensor can be connected to NovoCon® actuator, for precise measurement of flow. NovoCon® L actuator can be used for solutions with sizes from DN125 to DN150.

NovoCon® XL actuator can be used for solutions with sizes from DN200 to DN250.

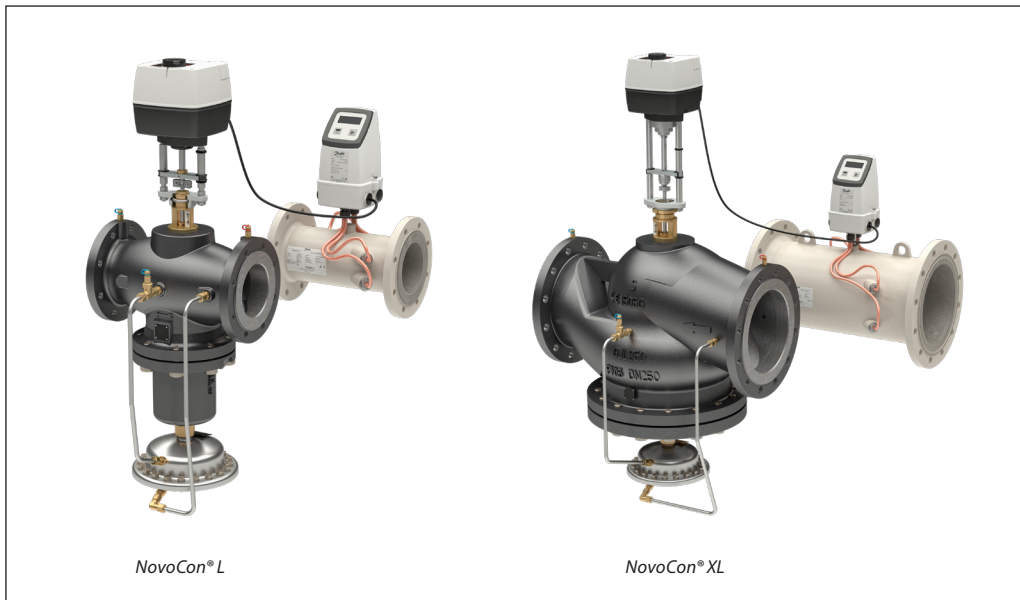

3.2 Ordering

DN125 - DN250

AB-QM flanged version

Picture	DN	Q _{nom.} (l/h)	Flange connection (EN 1092-1)	Code No.
	125	90,000	PN 16	003Z0705
	125 HF	110,000		003Z0715
	150	145,000		003Z0706
	150 HF	190,000		003Z0716
	200	200,000		003Z0707
	200 HF	270,000		003Z0717
	250	300,000		003Z0708
	250 HF	370,000		003Z0718

Temperature sensors

Type	Code No.
Immersed Pt 1000 / Ø 5.2 mm / 3.0 m cable, pair, MID	187F3419

Accessories

Designation	Code No.
Immersion brass-pockets, 85 mm, Ø 5.2 pair, MID. For pipes DN80-125	087G6055
Immersion brass-pockets, 120 mm, Ø 5.2 pair, MID. For pipes DN150-200	087G6056
Immersion stainless steel-pockets, 155mm, Ø 5.2 pair, MID. For pipes DN250	087G6059

3.3 Technical data

Nominal diameter		DN	125	125 HF	150	150 HF	200	200 HF	250	250 HF
Flow range	Q_{nom} (100 %) ¹⁾	l/h	90,000	110,000	145,000	190,000	200,000	270,000	300,000	370,000
	Q_{high} ³⁾		100,000	120,000	160,000	209,000	220,000	300,000	330,000	407,000
Setting range ²⁾		%	40-110							
Diff. pressure ^{3), 4), 5)}	Δp_{min}	kPa	40 (60)	60 (80)	40 (60)	60 (80)	45 (65)	60 (80)	45 (65)	60 (80)
	Δp_{max}		600	600	600	600	600	600	600	600
Pressure stage		PN	16							
Control range			1:1000							
Control valve's characteristic			Linear (could be converted by actuator to equal percentage)							
Leakage rate with recommended actuators			max.0.01 % of Q_{nom}							
Flow medium			Water and water mixture for closed heating and cooling systems according to plant type I for DIN EN 14868. When used in plant Type II for DIN EN 14868 appropriate protective measures are taken. The requirements of VDI 2035, part 1 + 2 are observed.							
Medium temperature		°C	-10 ... +120							
Storage and transport temp.			-40 ... 70							
Stroke		mm	30							
Connection	flange		PN 16							
	actuator		Danfoss standard							
Materials in the water										
Valve bodies			Grey iron EN-GJL-250 (GG 25)							
Membranes/ Bellow			W.Nr.1.4571	EPDM						
O-rings			EPDM							
Springs			W.Nr.1.4401	W.Nr.1.4310						
Cone (Pc)			W.Nr.1.4404NC	W.Nr.1.4021						
Seat (Pc)			W.Nr.1.4027							
Cone (Cv)			W.Nr.1.4404NC	W.Nr.1.4021						
Seat (Cv)			W.Nr.1.4027							
Screw			W.Nr.1.1181							
Flat gasket			Graphite gasket	Non asbestos						

¹⁾ Factory setting of the valve is done at nominal setting range.

²⁾ Regardless of the setting, the valve can modulate below 1 % of set flow.

³⁾ When set above 100 %, minimum starting pressure needed is higher, see figures in the ().

⁴⁾ In case AB-QM is used above 400 kPa differential pressure contact Danfoss design center to assure proper design.

⁵⁾ At min differential pressure valve reaches at least 90% of nominal flow. Declaration of performance is available upon request.

Pc - pressure controller part
Cv - Control valve part

3.4 I/O connections on NovoCon® L, XL

Flow sensor can be connected on any input on NovoCon® L/XL. Danfoss recommends using T3 input, so NovoCon® can still be controlled over AI and keep energy features.

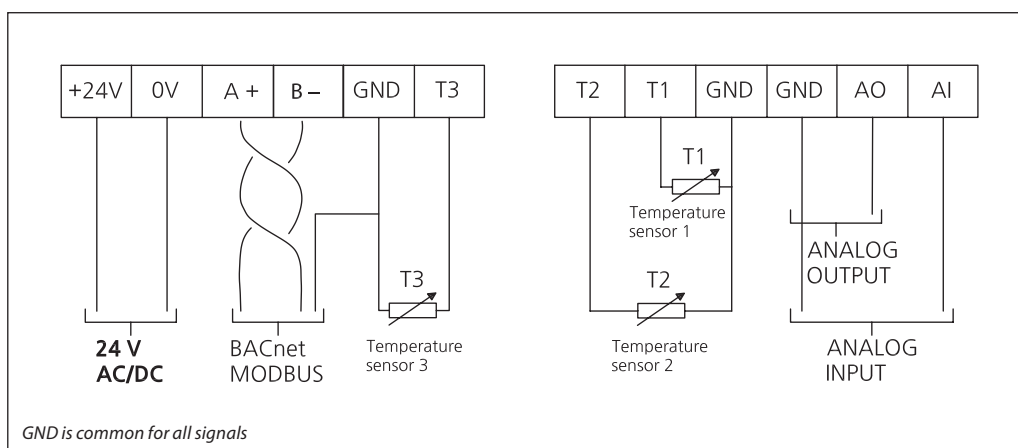

3.5 Immersed sensor

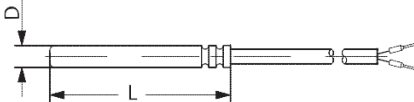
Temperature sensors	Installation	Type	Diameter D (mm)	Length L (mm)
	Immersed (direct) or in pocket (indirect)	Pt 1000	Ø 5.2	45

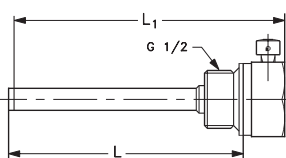
Sensors pockets	Type	Brass		Stainless steel
	Sensor diameter	(mm)		Ø 5.2
	Length	L1 (mm)	93	128
L (mm)		85	120	155

3.6 SONO 3500 CT

3.6.1 Description



The SONO 3500 CT is an ultrasonic flow sensor especially designed for heating, cooling or combined heating/cooling application in local and district energy systems. In combination with INFOCAL 9 it becomes energy meter for heating or cooling.

The SONO 3500 CT has been approved according to MID class 2. The approved flow sensor consists of a flow sensor pipe, 4 transducers with cables and a transmitter with LCD display.

Features

- Ultrasonic 2-path flow sensor secures measurement and optimum accuracy
- Galvanically isolated digital output for easy connection to energy calculator INFOCAL 9
- 115 / 230 V mains-powered with back-up battery as standard version in case of mains power failure
- Optional battery-powered version (up to 6 years lifetime)
- Fast measuring frequency 15 Hz / 0.5 Hz (230 V AC / Battery)
- Compact (standard) or remote mounting
- No pressure drop
- Long-term stability
- Easy one-button straight forward display

3.6.2 Technical specifications

Diameter	Nominal	DN (mm)	100	125	150	200	250	300	350	400	500	600	700	800	900	1000	1200
Flow rate ranges	Nominal	q _p (m³/h)	120	200	300	500	800	1120	1500	1900	2950	4300	5800	7600	10000	10000	10000
	Highest operatable	q _s (m³/h)	180	280	420	700	1120	1560	2100	2660	4130	6020	8120	10640	14000	14000	14000
	Maximum	q _{max} (m³/h)	189	294	441	735	1176	1638	2205	2793	4336.5	6321	8526	11172	14700	14700	14700
	Minimum	q _i (m³/h)	1.2	2	3	5	8	11.2	15	19	29.5	43	58	76	100	100	200
	Cut-off	m³/h	0.3	0.5	0.75	1.25	2	2.8	3.75	4.75	7.375	10.75	14.5	19	25	30	45
Operating pressure	Maximum	PN (bar)	16/40			16/25/40			16/25								16
Dynamic range		q _i : q _p	1:100														1:50
Pulse output value		l/p	2.5	2.5	2.5	10	10	10	10	50	50	100	100	100	100	100	100
Pulse width		ms	5														
Flow velocity		m/s	0.02 ... 9														
Measuring frequency		Hz	15 Hz (mains supply - standard) / 0.5 Hz (battery supply)														
Power supply	Mains supply (standard)		115 / 230V AC, including 3.6V single battery backup														
	Battery supply		3.6V battery version, incl. dual battery pack														
Medium			Heating water, according to VDI-2035 (pH 8.2 - 10.5), industrial VdTÜV 1466 and AGFW FW510														
Media/ surface temperature	Compact (standard)	°C	5 ... 120														
	Remote	°C	5 ... 200														
Basic features	Environmental class		MID class E2 + M1														
	Protection class		IP 67 according to EN 60529 and DIN 40050 (NEMA 4X/6)														
	Storage temperature	°C	-40 ... 85														
	Ambient temperature	°C	-10 ... 55														
Pipe material			Carbon Steel EN 1.0345 / P235 GH, painted in light-gray														
Remote version cable length			5 m / 10 m / 20 m / Max. 30 m between transmitter and flow sensor														

3.7 Cross reference table AB-QM - NovoCon®M - Flow sensor:

Valve code	Valve name	Valve connection	Actuator code	Actuator name	Flowmeter code	Flowmeter name	Flowmeter connection	NovoCon S cable	Temperature sensor code (PT1000)	Temperature pockets code
003Z0705	AB-QM DN125 90.0 m³/h	flange	003Z8560	NovoCon L	187F3530	SONO 3500 CT DN100 Qp 60.0 m3/h	flange	/	187F3419	087G6055
003Z0715	AB-QM DN125 HF 110.0 m³/h	flange	003Z8560	NovoCon L	187F3530	SONO 3500 CT DN100 Qp 60.0 m3/h	flange	/	187F3419	087G6055
003Z0706	AB-QM DN150 150.0 m³/h	flange	003Z8560	NovoCon L	187F3531	SONO 3500 CT DN125 Qp 100.0 m3/h	flange	/	187F3419	087G6056
003Z0716	AB-QM DN150 HF 190.0 m³/h	flange	003Z8560	NovoCon L	187F3531	SONO 3500 CT DN125 Qp 100.0 m3/h	flange	/	187F3419	087G6056
003Z0707	AB-QM DN200 220.0 m³/h	flange	003Z8563	NovoCon XL	187F3531	SONO 3500 CT DN125 Qp 100.0 m3/h	flange	/	187F3419	087G6056
003Z0717	AB-QM DN200 HF 285.0 m³/h	flange	003Z8563	NovoCon XL	187F3532	SONO 3500 CT DN150 Qp 150.0 m3/h	flange	/	187F3419	087G6056
003Z0708	AB-QM DN250 300.0 m³/h	flange	003Z8563	NovoCon XL	187F3532	SONO 3500 CT DN150 Qp 150.0 m3/h	flange	/	187F3419	087G6059
003Z0718	AB-QM DN250 HF 370.0 m³/h	flange	003Z8563	NovoCon XL	187F3532	SONO 3500 CT DN150 Qp 150.0 m3/h	flange	/	187F3419	087G6059

3.8 Commissioning/wiring

NovoCon® L/XL supports connection of flow sensor directly to NovoCon® inputs. Flow sensor must be connected to T3 and GND terminal. NovoCon must be set to digital mode (MSV:9/32810 = 2). You also need to select T3 (MSV: 44/32821) input for connecting flow sensor.

To get right flow sensor value it is very important to set right value of liters per pulse on NovoCon® (AV: 43/32864). Usually this is written on flow sensor specification sheet. If we would like to use flow sensor for calculating energy we must also change register MSV12/32814*.

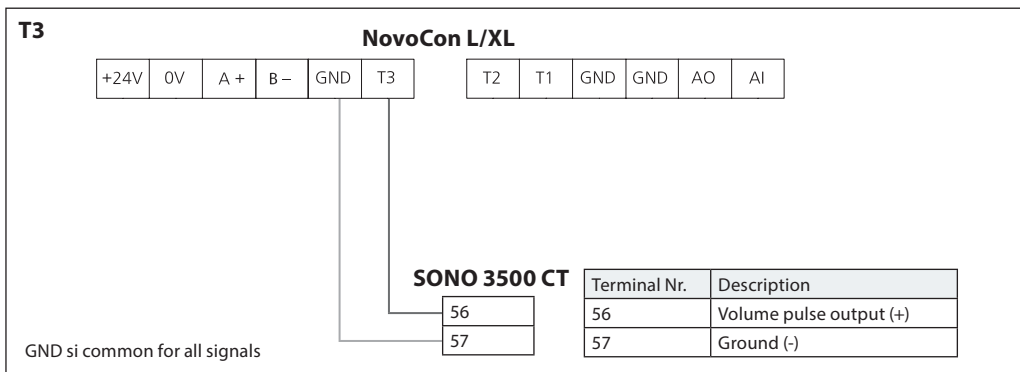

Object/Register	Write/read value	Description
MSV:44 / 32824	3: Flow sensor	T3 input
AV:43 / 32864	0,04 (depends on flow sensor)	Pulse volume (liter/pulse)
MSV:12 / 32814	3: ON, flow sensor on return pipe	Energy counting method*

*Energy counting method

MSV: 12 / 32814

State 1: Off

NovoCon® L/XL is not calculating energy.

State 2: On, indicated flow

NovoCon® L/XL is calculating energy based on temperature difference between T1 and T2 and using indicated flow.

State 3: On, flow sensor on return pipe

NovoCon® L/XL is calculating energy based on temperature difference between T1 and T2 and using flow from flow sensor installed on return pipe.

State 4: On, flow sensor on supply pipe

NovoCon® L/XL is calculating energy based on temperature difference between T1 and T2 and using flow from flow sensor installed on supply pipe.

3.9 BACnet and Modbus

3.9.1 Modbus registers

Configuration

Modbus register	Read/Write	Modbus function	Modbus Data Type	Object / Parameter name	Description	Default State	Description of usage	Persistent Yes/No
0x802E 32814	R/W	3, 4 & 6	WORD	Energy counting method	1: Off 2: On, indicated flow 3: On, flow sensor on return pipe 4: On, flow sensor on supply pipe	1: Off	State 1: Off NovoCon® is not calculating energy. State 2: On, indicated flow NovoCon® is calculating energy based on temperature difference between T1 and T2 and using indicated flow. State 3: On, flow sensor on return pipe NovoCon® is calculating energy based on temperature difference between T1 and T2 and using flow from flow sensor installed on return pipe. State 4: On, flow sensor on supply pipe NovoCon® is calculating energy based on temperature difference between T1 and T2 and using flow from flow sensor installed on supply pipe.	Yes

Configuration #2

Modbus register	Read/Write	Modbus function	Modbus Data Type	Object / Parameter name	Description	Default State	Unit	Description of usage	Persistent Yes/No
0x8033 32819	R/W	3, 4 & 6	WORD	T1, T2 temperature sensor type	Select the type of Temperature sensor connected for T1 and T2.	3: PT1000	na	Select temperature sensor type: 2: NTC10k Type 3 1: NTC10k Type 2 3: PT1000	Yes
0x8034 32820**	R/W	3, 4 & 6	WORD	T3 temperature sensor type	Select the type of Temperature sensor connected for T3.	3: PT1000	na	Select temperature sensor type: 3: PT1000 1: NTC10k Type 2 4: PT500 2: NTC10k Type 3 5: PT100	Yes
0x8035 32821	R/W	3, 4 & 6	WORD	AI input	Different options for analog input terminal	2: Analog input	na	1: Disabled 2: Analog input (voltage/current) 3: Flow sensor*	Yes
0x8036 32822	R/W	3, 4 & 6	WORD	T1 input	Different options for T1 terminal	2: Supply temp.	na	1: Disabled 3: Return temperature 2: Supply temperature 4: Flow sensor	Yes
0x8037 32823	R/W	3, 4 & 6	WORD	T2 input	Different options for T2 terminal	3: Return temp.	na	1: Disabled 3: Return temperature 2: Supply temperature 4: Flow sensor	Yes
0x8038 32824**	R/W	3, 4 & 6	WORD	T3 input	Different options for T3 terminal	2: Control temp.	na	1: Disabled 3: Flow sensor 2: Control temperature sensor	Yes
0x8060 32864	R/W	3, 4 & 16	FLOAT	Pulse volume	Pulse volume of connected flow sensor	0,4 l/p	Litre/pulse	Adapts automatically to the selected AB-QM valve, but can be overwritten manually. If set to 0 NovoCon only count pulses and do not perform flow measurements based on received pulses. This can be used to connect e.g. water meter or energy meter.	Yes

* Not suitable for SONO 3500 CT!

** Only for NovoCon M, L/XL

Operating

Modbus register	Read/Write	Modbus function	Modbus Data Type	Object / Parameter name	Description	Default State	Unit	Description of usage	Persistent Yes/No
0x8210 33296	R	3, 4	FLOAT	Volume counter	Total accumulated water volume	0	L	Total accumulated water volume passed through the valve, combined from both heating and cooling	Yes
0x8212 33298	R	3, 4	FLOAT	Pulse counter	Total accumulated number of pulses	0	pulse	Total accumulated number of pulses received from flow sensor	Yes

Alarms & warning

Modbus register	Read/Write	Modbus function	Modbus Data Type	Object / Parameter name	Description	Default State	Description of usage	Persistent Yes/No
0x8300 33536	R	3, 4	FLOAT	Warning: Flow out of expectations	Warning for lower or higher flow than expected	0: OFF	Bit 25 0:OFF 1:ON	No
				Warning: No flow detected	Flow sensor does not recognize any flow, through flow sensor	0: OFF	Bit 26 0:OFF 1:ON	No

3.9.2 BACnet Objects - Multi State Value

Ident	Object / Parameter name	Read/Write	State Text	Default State	Description	Persistent Yes/No
MSV:12	Energy counting method	R/W	1: Off 2: On, indicated flow 3: On, flow sensor on return pipe 4: On, flow sensor on supply pipe	1: Off	State 1: Off NovoCon® is not calculating energy. State 2: On, indicated flow NovoCon® is calculating energy based on temperature difference between T1 and T2 and using indicated flow. State 3: On, flow sensor on return pipe NovoCon® is calculating energy based on temperature difference between T1 and T2 and using flow from flow sensor installed on return pipe. State 4: On, flow sensor on supply pipe NovoCon® is calculating energy based on temperature difference between T1 and T2 and using flow from flow sensor installed on supply pipe.	Yes
MSV:14**	T1, T2 temperature sensor type	R/W	Select temperature sensor type: 1: NTC10k Type 2 2: NTC10k Type 3 3: PT1000 4: PT500 5: PT100	3: PT1000	Select the type of Temperature sensor connected for T1 and T2.	Yes
MSV:15**	T3 temperature sensor type	R/W	Select temperature sensor type: 1: NTC10k Type 2 2: NTC10k Type 3 3: PT1000 4: PT500 5: PT100	3: PT1000	Select the type of Temperature sensor connected for T3	Yes
MSV: 41	AI input	R/W	1: Disabled 2: Analog input (voltage/current) 3: Flow sensor*	2: Analog input	Different options for analog input terminal	Yes
MSV: 42	T1 input	R/W	1: Disabled 2: Supply temperature 3: Return temperature 4: Flow sensor	2: Supply temp.	Different options for T1 terminal If MSV:24 or MSV:25 or MSV:26 is on value 3, then value is for resistance, not temperature.	Yes
MSV: 43	T2 input	R/W	1: Disabled 2: Supply temperature 3: Return temperature 4: Flow sensor	3: Return temp.	Different options for T2 terminal If MSV:24 or MSV:25 or MSV:26 is on value 3, then value is for resistance, not temperature.	Yes
MSV:44**	T3 input	R/W	1: Disabled 2: Control temperature 3: Flow sensor	2: Control temp.	Different options for T3 terminal If MSV:24 or MSV:25 or MSV:26 is on value 3, then value is for resistance, not temperature.	Yes

* Not suitable for SONO 3500 CT!

** Only for NovoCon M, L/XL

BACnet Objects - Analog Value

Ident	Object / Parameter name	Unit	Read/Write	Min	Max	Default State	Resolution	Description	Persistent Yes/No
AV:27	Alarm summary count	No units	R	na	na	0	na	Numerical overview about pending errors detected. Coding for AV:27 Alarm summary count is: If BV:10 is active then AV:27 is 1.0. If BV:11 is active then AV:27 is 2.0. If BV:12 is active then AV:27 is 4.0. If BV:13 is active then AV:27 is 8.0. If BV:14 is active then AV:27 is 16.0. If BV:15 is active then AV:27 is 32.0. If BV:16 is active then AV:27 is 64.0. If BV:17 is active then AV:27 is 128.0. If BV:18 is active then AV:27 is 256.0. If BV:19 is active then AV:27 is 512.0. If BV:20 is active then AV:27 is 1024.0. If BV:21 is active then AV:27 is 2048.0. If BV:22 is active then AV:27 is 4096.0. If BV:23 is active then AV:27 is 8192.0. If BV:24 is active then AV:27 is 16384.0. If BV:25 is active then AV:27 is 32768.0. If BV:26 is active then AV:27 is 65536.0. e.g. if both BV:11 & BV:12 are active then AV:27 is 6.0. This object is supported by COV	No

Ident	Object / Parameter name	Unit	Read/Write	Min	Max	Default State	Description	Information	Persistent Yes/No
AV: 43	Pulse volume	Litre/pulse (l/p)	R/W	0	na	0	Pulse volume of connected flow sensor	Adapts automatically to the selected AB-QM valve, but can be overwritten manually. If set to 0 NovoCon only count pulses and do not perform flow measurements based on received pulses. This can be used to connect e.g. water meter or energy meter.	Yes
AV: 44	Volume counter	m3	R	0	na	0	Total accumulated water volume	Total accumulated water volume passed through the valve, combined from both heating and cooling	Yes
AV: 45	Pulse counter	pulse	R	0	na	0	Total accumulated number of pulses	Total accumulated number of pulses received from flow sensor	Yes

BACnet Objects - Binary Value

Ident	Object / Parameter name	Read/Write	Active Text (1)	Inactive Text (0)	Default State	Description	Persistent Yes/No
BV: 25	Warning: Flow out of expectations	R	ON	OFF	na	Warning for lower or higher flow than expected	No
BV: 26	Warning: No flow detected	R	ON	OFF	na	No flow detected with flow sensor	No

Danfoss A/S

Climate Solutions • danfoss.com • +45 7488 2222

Any information, including, but not limited to information on selection of product, its application or use, product design, weight, dimensions, capacity or any other technical data in product manuals, catalogues descriptions, advertisements, etc. and whether made available in writing, orally, electronically, online or via download, shall be considered informative, and is only binding if and to the extent, explicit reference is made in a quotation or order confirmation. Danfoss cannot accept any responsibility for possible errors in catalogues, brochures, videos and other material. Danfoss reserves the right to alter its products without notice. This also applies to products ordered but not delivered provided that such alterations can be made without changes to form, fit or function of the product.

All trademarks in this material are property of Danfoss A/S or Danfoss group companies. Danfoss and the Danfoss logo are trademarks of Danfoss A/S. All rights reserved.