

Technical Information

Medium Duty Closed Circuit Piston Motors

Variable Displacement and Fixed Displacement

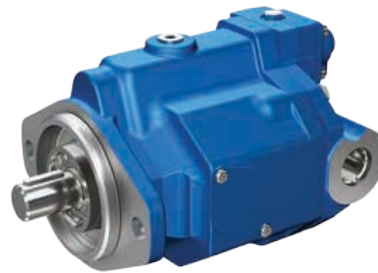

Medium Duty Closed Circuit Piston Motors

Table of Contents

Introduction and Application Information	3
Fixed Displacement Motors	4
Features and Benefits.....	4
741XX Models Specification	5
Model 74111 Performance Data, 12.3 cm ³ /r [.75 in ³ /r] Displacement	5
Model 74118 Performance Data, 20.3 cm ³ /r [1.24 in ³ /r] Displacement	5
Model Code	7
Output Shafts.....	8
Installation Drawings.....	9
743XX Models Specifications	10
Model 74315 Performance Data, 32.9 cm ³ /r [2.01 in ³ /r] Displacement.....	11
Model 74318 Performance Data, 40.6 cm ³ /r [2.48 in ³ /r] Displacement	11
Model 74328 Performance Data, 49.2 cm ³ /r [3.0 in ³ /r] Displacement.....	11
Model Code	12
Output Shafts.....	13
Installation Drawings - Model 74315, 74318, 74328.....	14
Installation Drawings - Model 74348.....	15
Anti Cavitation Check Valve	15
Shuttle Valve	16
Speed Sensor	18
746XX Models - High Torque Fixed Displacement Motor Specifications	19
Model 74624 Performance Data, 82.6 cm ³ /r [5.04 in ³ /r] Displacement	19
Model Code	21
Output Shafts.....	22
Installation Drawings.....	23
Variable Displacement Motors	24
Features and Benefits.....	24
71392 Model 40.6 cm³/r [2.48 in³/r] Displacement Specifications	25
Working Principle.....	25
Model Code	26
Installation Drawings.....	27
Controls Options.....	28
Output Shafts.....	28
72450 Models - Servo Controlled, 40.6 cm³/r [2.48 in³/r], 49.2 cm³/r [3.0 in³/r] Specifications	29
Working Principle.....	30
Performance Data, 40.6 cm ³ /r [2.48 in ³ /r], 36.7 cm ³ /r [2.24 in ³ /r] Displacement.....	30
Performance Data, 26.7 cm ³ /r [1.63 in ³ /r], 23.6 cm ³ /r [1.44 in ³ /r] Displacement.....	30
Model Code	31
Output Shafts.....	31
Installation Drawings.....	32
Shuttle Valve	33
Speed Sensor	33
Component Selection	34

General Overview

Introduction

Danfoss Medium Duty Piston Motors convert hydraulic energy supplied by the pump to mechanical energy. These motors are uniquely suited to fit any application that requires continuous rotary motion at a remote location from the power source. Axial piston motors share the design advantages of piston pumps to provide long-lasting power in a lightweight, easily serviceable package.

The table below provides an overview of features. For a complete list of options, refer to the Model Code section of a given motor displacement.

Typical Applications

Agriculture Equipment

- Harvesters
- Sprayers
- Feed Mixer

Forestry Equipment

- Log Skidders
- Bark Removers
- Limb Removers

Construction Equipment

- Mini Backhoe
- Asphalt Paver
- Fan Drives
- Sweepers

Turf Care Equipment

- Mowers
- Lawn Tractors

Industrial Equipment

- Lift Trucks
- Scissor Lifts
- Telescopic lifts

MOTORTYPE	MOUNT 2 BOLT	MOTOR MODEL	DISPLACEMENT	SHAFT KEYED	SHAFT SPLINE	SHAFT THROUGH	PORTING
Fixed Displacement							
741XX Models	SAE "A"	74111	12.3 cm ³ /r [.75 in ³ /r]	•	•		Same or Opp. or Rear side
		74115	16.6 cm ³ /r [1.01in ³ /r]	•	•		Same or Opp. or Rear side
		74118	20.3 cm ³ /r [1.24 in ³ /r]	•	•		Same or Opp. or Rear side
		74119	9.8 cm ³ /r [.60 in ³ /r]	•	•		Same or Opp. or Rear side
		74148	20.3 cm ³ /r [1.24 in ³ /r]	•	•	•	Same Side
		74149	16.6 cm ³ /r [1.01 in ³ /r]	•	•	•	Same Side
743XX Models	SAE "B"	74315	32.9 cm ³ /r [2.01 in ³ /r]	•	•		Same or Opp. or Rear side
		74318	40.6 cm ³ /r [2.48 in ³ /r]	•	•		Same or Opp. or Rear side
		74328	49 cm ³ /r [3.0 in ³ /r]	•	•		Same or Opp. or Rear side
		74348	40.6 cm ³ /r [2.48 in ³ /r]	•	•	•	Same Side
746XX Models	"B-B"	74624	82.6 cm ³ /r [5.04 in ³ /r]	•	•		Same Side or Rear
		74644	82.6 cm ³ /r [5.04 in ³ /r]	•	•	•	Same Side or Rear
Variable Displacement							
Variable Motor	SAE "B"	71392	40.6 to 21.0 cm ³ /r [2.48 to 1.28 in ³ /r]	•	•		Opposite Side or Rear
Servo Control 72450		72450	40.6 to 21.0 cm ³ /r [2.48 to 1.28 in ³ /r]	•	•	•	Same Side
	SAE "B"	72450	49.2 to 24.6 cm ³ /r [3.0 to 1.5 in ³ /r]	•	•	•	Same Side

General Overview

Features & Benefits

- Compact - Ease of Installation
- Efficient axial piston design
- Numerous Options - Shafts, Ports, Shuttle Valves, Speed Pickup
- Wide Displacement range: 9.8 cc (0.60 cid) to 82.6 cc (5.04 cid)
- Optional shuttle, back pressure valve - improved loop cooling, flushing
- Optional Speed Sensor Available (9 pulse/rev.) - 50 RPM min
- Good in reliability & performance
- Worldwide sales & services

2 Bolt SAE "A" Mount - 741XX Series

9.8 cm³/r [.60 in³/r] Displacement

20.3 cm³/r [1.24 in³/r] Displacement



2 Bolt SAE "B" Mount - 743XX Series

32.9 cm³/r [2.01 in³/r] Displacement

40.6 cm³/r [2.48 in³/r] Displacement

49.2 cm³/r [3.00 in³/r] Displacement



2 Bolt SAE "B-B" Mount - 746XX Series

82.6 cm³/r [5.04 in³/r] Displacement



Model 741XX Fixed Displacement Motor

2 Bolt SAE A Mount

9.8 cm³/r [.60 in³/r] Displacement

20.3 cm³/r [1.24 in³/r] Displacement

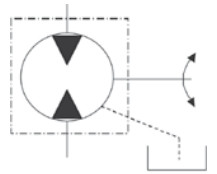

Identification numbers – Fixed Displacement Motor - Closed Circuit
Stamped on each unit.

7 4 1 X X - D A A - 0 1
 A B C D

A – Product Number Description

74111 = 12.3 cm³/r [0.75 in³/r]

74115 = 16.6 cm³/r [1.01 in³/r]

74118 = 20.3 cm³/r [1.24 in³/r]

74119 = 9.8 cm³/r [.60 in³/r]

74148 = 20.3 cm³/r [1.24 in³/r] with Thru Shaft Back-plate

74149 = 12.3 cm³/r [0.75 in³/r] with Thru Shaft Back-plate



B – Rotation

D = Dual

C – Sequential Letter

D – Design Code number

Serial Number Code

10 05 06 XXX 1 000

Last Two Digits of Year Built. (10 for 2010 etc.)

Month Built (two digits)

Day Built (two digits)

Specific Number of the Pump

Shift Number

Manufacturing Cell

TYPICAL PRODUCT NUMBER	MODEL CODE
74111-DAC-01	AAVAAAA0B000A0B
74111-DAF-01	AAVAEAA0B000A0B
74118-DAJ-01	AAVAAAA00000A0B
74118-DAS-01	AAVAAAB00000A0B

SPECIFICATIONS	MODEL 74111/74119	MODEL 74118/74148
Maximum Displacement	12.3 cm ³ /r [.75 in ³ /r]	20.3 cm ³ /r [1.24 in ³ /r]
Maximum Rated Speed	4500 RPM	3600 RPM
Nominal Pressure Rating †	350 bar [5076 lbf/in ²]	350 bar [5076 lbf/in ²]
Peak Pressure Rating ††	370 bar [5400 lbf/in ²]	370 bar [5400 lbf/in ²]
Input Flow at Rated Speed and Pressure	66.37 l/min [14.6 GPM]	87.74 l/min [19.3 GPM]
Output Power at Rated Speed and Pressure	32.30 kW [43.28 hp]	42.65 kW [57.25 hp]
Output Torque at Rated Speed and Pressure	68.55 N•m [606.21 lbf•in]	113.14 N•m [1002.27 lbf•in]
Continuous Allowable Case Pressure	1.7 bar [25 lbf/in ²]	1.7 bar [25 lbf/in ²]
Continuous Inlet Temperature	107° C [225° F]	107° C [225° F]
Weight/Single Motor (approximate)	4.9 kg [11 lbs]	4.9 kg [11 lbs]

† Nominal Pressure: Max. delta system pressure at which component fatigue does not occur (motor life estimated by bearing life).

†† Peak Pressure: Max. operation pressure which is permissible for a short duration of time (t < 1 sec).

Model 741XX Fixed Displacement Motor

Compact axial piston design with de-stroked 9.8, 12.3, 14.96, 16.6 & 20.3 cm³/r displacement options. Uses lightweight aluminum housing & end cover with same side & opposite side porting options. Numerous output shafts with through drive capabilities for brake mounting.

End cover houses main ports and gauge ports. Improved thrust load capacities.* Attached cross section view shows major components of the motor.

*Contact Danfoss representative.

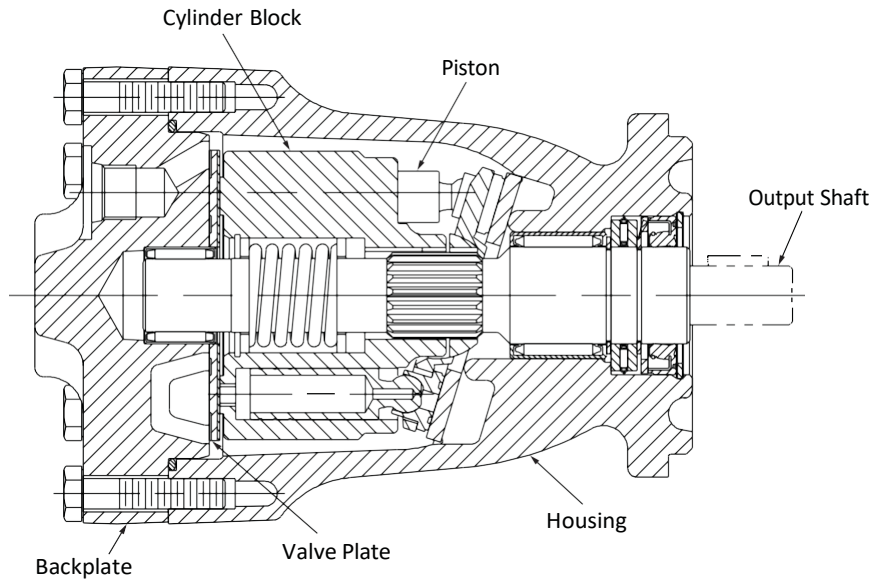

Model 741XX Fixed Displacement Motor

Model Code

12.3 cm³/r [.75 in³/r] Displacement

20.3 cm³/r [1.24 in³/r] Displacement

Fixed displacement piston motors are specified by the following model code. Once a motor is built from the model code, a product number will be assigned to that configuration.

Make sure all positions are selected within the 15 digit code for each motor.

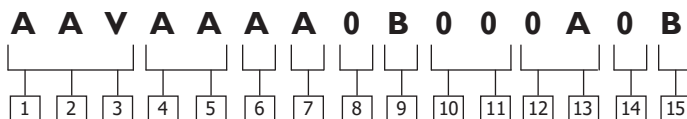

1 2 3 Code Title

AAV - 20.3 cm³/r [1.24 in³/r]
Fixed displacement piston motor frame size

4 5 Output Shaft

AA - 13 Tooth 16/32 spline with snap ring groove, min. full spline 22.1 [.87], shaft extension 41.1 [1.62], (std.)

AE - Straight shaft, dia. 22.2[.875], keyway 6.35 [.25] x 25.4[1.00], shaft extension 41.1 [1.62] (key included), (std.)

AH - Diameter 22.3 [.88] taper .125:1, keyway 6.35 X 25.4 [.25 X 1.00], .625-18 UNF-2A, shaft extension 66.5 [2.62] (key included)

6 Main Port, Size, & Location

A - 1-1/16-12 UN-2B straight thread O-ring ports opposite sides, (std.)

B - 1-1/16-12 UN-2B straight thread O-ring ports- rear, (std.)

C - 1-1/16-12 UN-2B straight thread O-ring ports- same side, only with through shaft, (opt.)

D - .875-14 UNF-2B SAE O-ring ports opposite sides

7 Drain Port, Size, & Location

A - 9/16-18 UNF-2B straight thread O-ring port - upper rear, (std.)

B - 9/16-18 UNF-2B straight thread O-ring port - lower rear, (std.)

C - 9/16-18 UNF-2B straight thread O-ring port - bottom rear, with through shaft only (pos. 8, selection 1), (std.)

8 Auxiliary Mounting Features (rear)

0 - No Auxiliary Mounting Feature

I* - Straight through shaft, dia. 19 [.75], with keyway 4.8 x 31 [.189 x 1.22], 209.3 [8.42] from mounting flange (Key included), 5/16 - 18 UNC-2B mounting holes 14.2 [.56] deep min. full thread, (opt.)

Note: Requires the selection in position 6 of same side porting. (opt.)

9 Displacement Options

0 - As given in code title. - Model 74118 or 74148, (std.)

A - 16.6 cm³/r [1.01 in³/r] destoked from 20.3 cm³/r [1.24 in³/r], (opt.)

B - 12.3 cm³/r [.75 in³/r] destoked from 20.3 cm³/r [1.24 in³/r] - Model 74111 or 74149, (std.)

C - 9.8 m³/r [.60 in³/r] destoked from 20,3 cm³/r [1.24] in³/r, (opt.)

D - 14.96 m³/r [.91 in³/r] destoked from 20.3 cm³/r [1.24] in³/r, (opt.)

10 11 Special Features

00 - No Special Features, (std.)

AF - Reduced drive shaft end play, Internal case drain with check, 2 degree valving, and no drive shaft key

AK - Rotating group and bearing for high speed application

AR - 5000 rpm speed rating and components (for 20.3 cc)

12 13 Paint

0A - Primer, (std.)

0B - Black Paint, (std.)

14 Identification

0 - Standard, (std.)

15 Design Code

B - Valve Plate

Model 74148 & 74149 Fixed Displacement Motor

Output Shafts and Installation Drawings

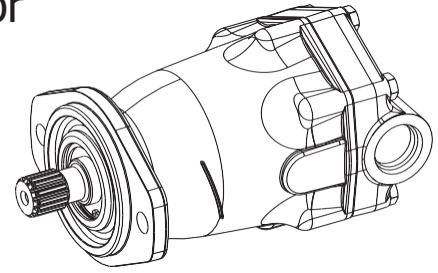

Output Shaft

Used For All 741XX Models

(Code Position 4, 5)

Splined Shaft

Selection AA

Maximum Torque on Shaft
209.3 N-m [1,852 lbf-in]

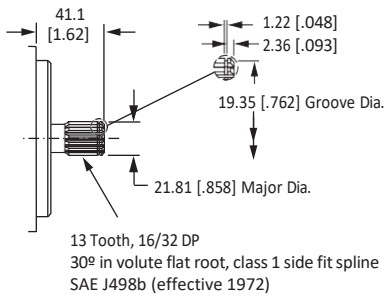

Keyed Shaft

Selection AE

Maximum Torque on Shaft
209.3 N-m [1,852 lbf-in]

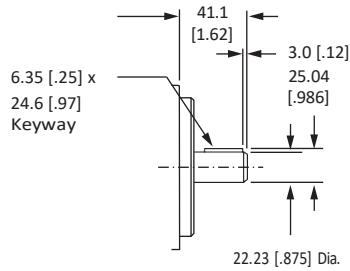

Keyed Shaft

Selection AH

Maximum Torque on Shaft
209.3 N-m [1,852 lbf-in]

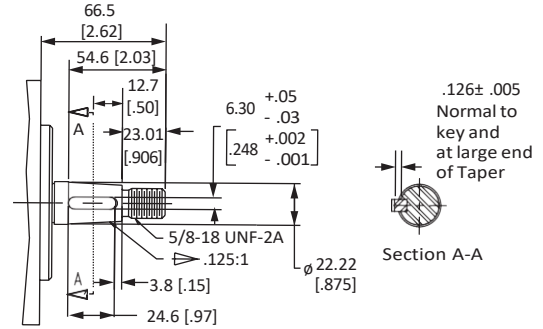

Installation Drawing

Opposite Side Porting

(Code position 6, Selection A)

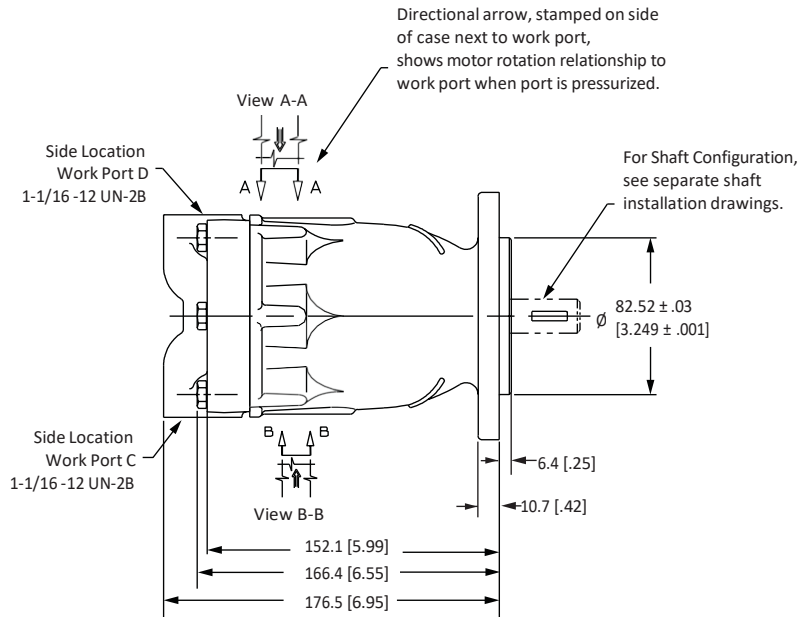
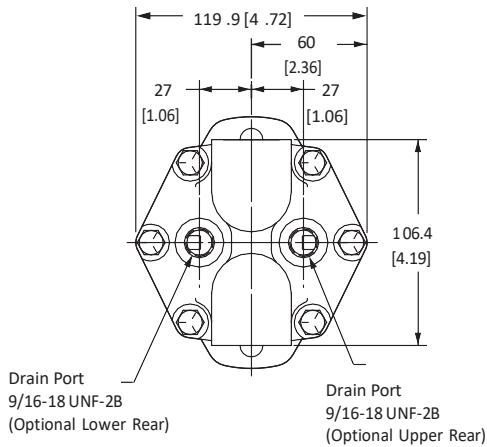

Note: All ports are SAE (J1926) O-ring ports. Dimensions are in millimeters [inches], unless otherwise specified.

Model 74148 & 74149 Fixed Displacement Motor

Installation Drawings

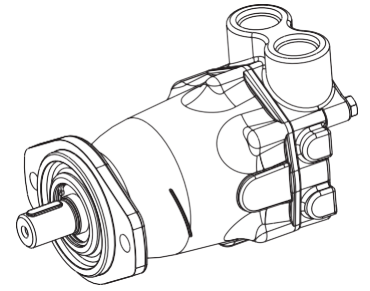

Rear Porting

(Code position 6, Selection B)

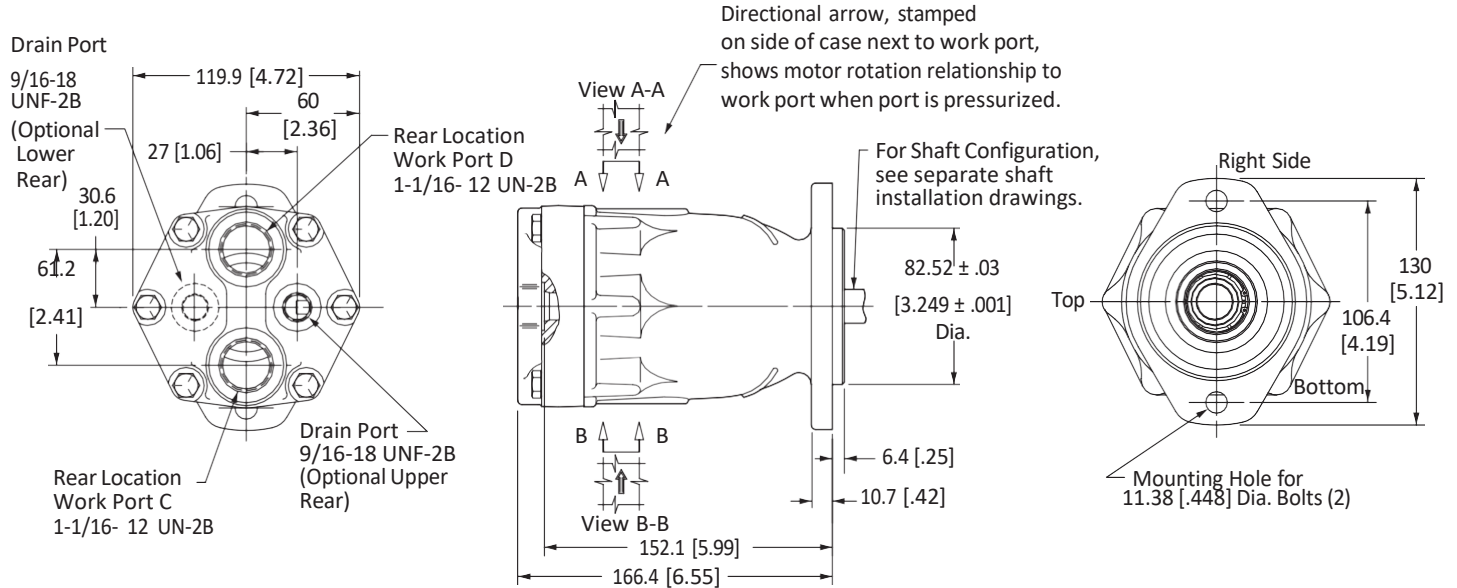

Through Shaft and Same side porting

(Code position 6, Selection C)

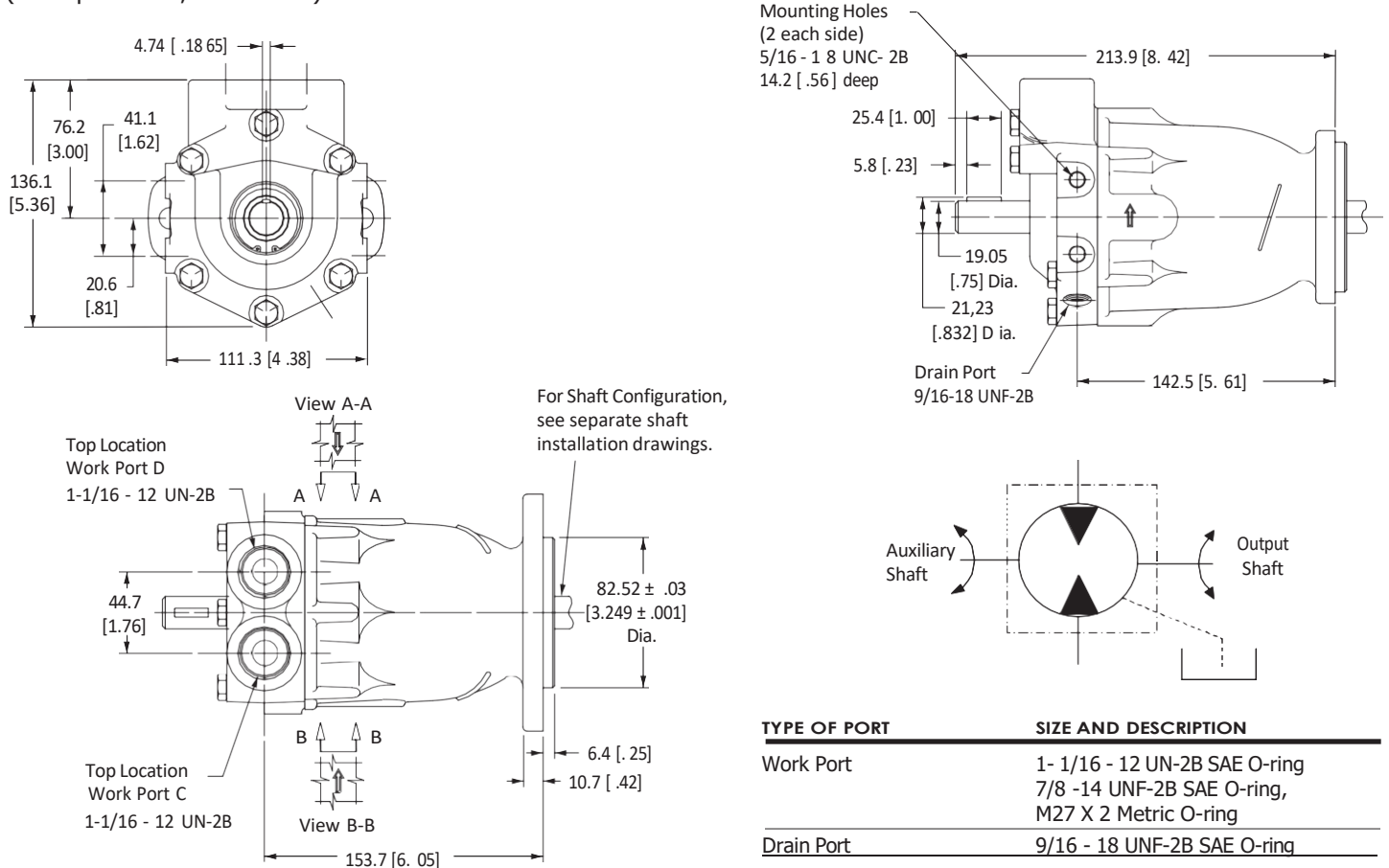

Note: All ports are SAE (J1926) O-ring ports. Dimensions are in millimeters [inches], unless otherwise specified.

Model 74315 Fixed Displacement Motor

2 Bolt SAE B Mount

24.6 cm³/r [1.50 in³/r] Displacement

40.6 cm³/r [2.48 in³/r] Displacement

49.2 cm³/r [3.00 in³/r] Displacement

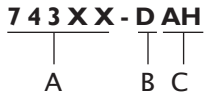

Identification numbers – Fixed Displacement Motor - Closed Circuit
Stamped on each unit.

A – Product Number Description

74315 = 32.9 cm³/r [2.01 in³/r]

74318 = 40.6 cm³/r [2.48 in³/r]

74328 = 49.2 cm³/r [3.00 in³/r]

74348 = 40.6 cm³/r [2.48 in³/r] with thru shaft backplate

B – Rotation

D = Dual

C – Sequential Letter

Serial Number Code

10 05 06 XXX I 000

Last Two Digits of Year Built.(10 for 2010 etc.)

Month Built (two digits)

Day Built (two digits)

Specific Number of the Pump

Shift Number

Manufacturing Cell

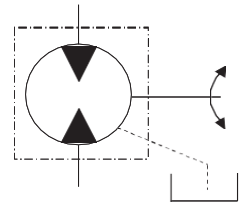

TYPICAL PRODUCT NUMBER	MODEL CODE
74315-DAL	AAJAADB0AAD0A0B
74318-DAA	AAJAADA00000A0B
74318-DAB	AAJAABA00000A0B
74328-DAA	AAKABAJ00000A0B
74328-DAB	AAKAAAB0000000B



SPECIFICATIONS	MODEL 74315	MODEL 74318/74348	MODEL 74328
Maximum Displacement	32.9 cm ³ /r [2.01 in ³ /r]	40.6 cm ³ /r [2.48 in ³ /r]	49.2 cm ³ /r [3.0 in ³ /r]
Maximum Rated Speed	3600 RPM	3600 RPM	3000 RPM
Nominal Pressure Rating †	350 bar [5000 lbf/in ²]	350 bar [5000 lbf/in ²]	315 bar [4570 lbf/in ²]
Peak Pressure Rating ††	370 bar [5400 lbf/in ²]	370 bar [5400 lbf/in ²]	345 bar [5000 lbf/in ²]
Input Flow at Rated Speed and Pressure	142.43 l/min [31.33 GPM]	175.71 l/min [38.65 GPM]	177.12 l/min [38.96 GPM]
Output Power at Rated Speed and Pressure	69.13 kW [92.80 hp]	85.30 kW [114.50 hp]	77.53 kW [104.61 hp]
Output Torque at Rated Speed and Pressure	183.36 N•m [1624.64 lbf•in]	226.27 N•m [2004.54 lbf•in]	246.78 N•m [2197.68 lbf•in]
Continuous Allowable Case Pressure	1.7 bar [25 lbf/in ²]	1.7 bar [25 lbf/in ²]	1.7 bar [25 lbf/in ²]
Continuous Inlet Temperature	107° C [225° F]	107° C [225° F]	107° C [225° F]
Weight/Single Motor (approximate)	9.1 kg [20 lbs]	9.1 kg [20 lbs]	9.1 kg [20 lbs]

† Nominal Pressure: Max delta system pressure at which component fatigue does not occur (motor life estimated by bearing life).

†† Peak Pressure: Max operation pressure which is permissible for a short duration of time (t < 1 sec).

Model 74315 Fixed Displacement Motor

Compact axial piston design with de-stroked 24.6, 29.5, 32.9, 40.6 and 49.3 cm³/r displacement options. Uses lightweight aluminum housing with speed sensor mounting option. End cover with same side, rear side & opposite side working ports. Numerous output shafts with through drive capabilities for brake mounting. End cover houses main

ports, gauge ports, shuttle valve back pressure relief valve. Improved thrust load capacities.*

Attached cross section view shows major components of the motor.

*Contact Danfoss representative.

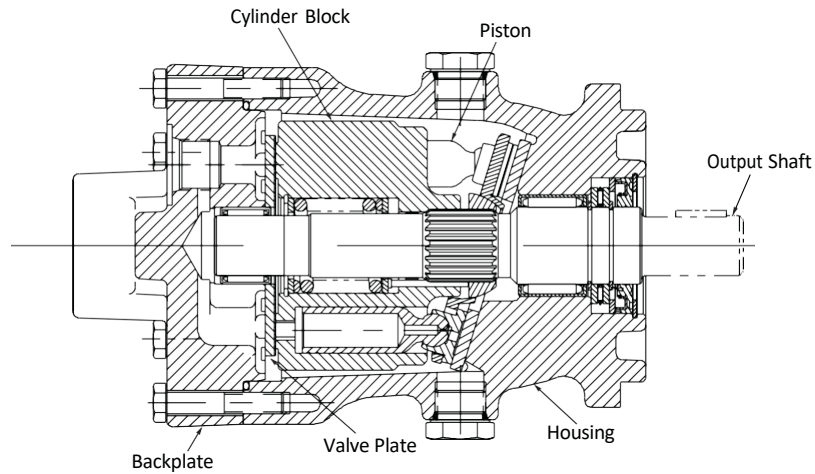

Model 74315 Fixed Displacement Motor

Model Code

2 Bolt SAE B Mount

32.9 cm³/r [2.01 in³/r] Displacement

40.6 cm³/r [2.48 in³/r] Displacement

49.2 cm³/r [3.00 in³/r] Displacement

Fixed displacement piston motors are specified by the following model code. Once a motor is built from the model code, a product number will be assigned to that configuration.

Make sure all positions are selected within the 15 digit code for each motor.

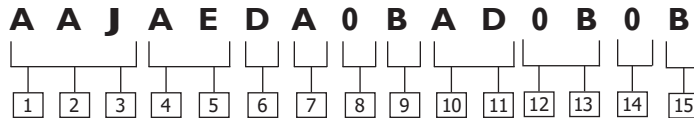

[1][2][3] Code Title

AAJ - 40.6 cm³/r [2.48 in³/r]

Fixed displacement piston motor frame size

AAK - 49.2 cm³/r [3.0 in³/r]

Fixed displacement piston motor frame size

[4][5] Output Shaft

AA - 13 Tooth 16/32 spline shaft extension 41.1 [1.62], (std.)

AB - 15 Tooth 16/32 spline, shaft extension 46 [1.81], (opt.)

AD - Straight Shaft, dia. 28.58 [1.125], keyway 7.9 [.31] x 32.5 [1.28], shaft extension 46 [1.81] (key included), (opt.)

BF - Straight shaft, dia 22.23 [.875], keyway 6.4 X 55.6 [.25 X 2.19], shaft extension 71.4 [2.81] (Key included)

[6] Main Port, Size, & Location

A - 1-1/16-12-12 UN-2B straight thread O-ring ports- opposite sides, (opt.)

B - 1-5/16-12 UN-2B straight thread O-ring ports- opposite sides, (std.)

C - 1-5/16-12 UN-2B straight thread O-ring ports- rear, (std.)

D - 1-5/16-12 UN-2B straight thread O-ring ports- same side, Top, (opt.)

E - 1-1/16-12 UN-2B straight thread O-ring ports- rear, (opt.)

J - 1-1/16-12 UN-2B straight thread O-ring ports- same side, Top, (opt.)

M - M33 X 2 Metric O-ring ports - Top

[7] Drain Port, Size, & Location

A - 3/4-16 UNF-2B straight thread O-ring port - Top of Housing, (std.)

B - 3/4-16 UNF-2B straight thread O-ring port - Top and bottom of Housing, bottom plugged, (opt.)

G - 3/4-16 UNF-2B straight thread O-ring port - upper rear of Backplate, (opt.)

J - 9/16-18 UNF-2B straight thread O-ring port-upper rear of Backplate, (opt.)

[8] Auxiliary Mounting Features (rear)

0 - No Auxiliary Mounting Feature (std.)

3* - Straight through shaft, dia. 22.23 [.875], with keyway 4.75 x 26.9 [.187 x 1.06] (key included, 19 [.75] long). Side Mounting Pad holes both sides, 4 x .3125- 18.

***Note:** Requires the selection in position 6 of same side porting. (opt.)

[9] Displacement Options

0 - As given in code title, 40.6 cm³/r [2.48 in³/r] - Model 74318 or 74348, (std.)

A - 32.9 cm³/r [2.01 in³/r] destroked from 40.6 cm³/r [2.48 in³/r] - Model 74315, (opt.)

B - 24.6 cm³/r [1.50 in³/r] destroked from 40.6 cm³/r [2.48], (opt.)

C - 29.5 cm³/r [1.80 in³/r] Modified from A 40.6 cm³/r [2.48 in³/r]

[10][11] Special Features

00 - No special feature, (std.)

AD - Shuttle Valve and Charge Pressure Valve set at 15-17 bar [220- 250 lbf/in²], (opt.)

AM - Shuttle Valve and Charge Pressure Valve set at 10-12 bar [150- 175 lbf/in²], (opt.)

AN - Speed sensor magnetic pickup (9 Pulse), 3 pin weather pack connector with 127 [5.0] lead wire

AP - Speed sensor magnetic pickup (9 Pulse), 3 pin metri-pack connector with 127 [5.0] lead wire

AY - 6.20 bar [90.0 lbf/in²] Static seal with adaptor and unidirectional RH (CW) rotation with anti-cavitation check valve

AZ - 2 Way shuttle valve with back-pressure valve set at 5.2-7.2 bar [75-105 lbf/in²]; viton drive shaft seal

BF - 6.20 bar [90.0 lbf/in²] Static seal with adapter and unidirectional LH (CCW) rotation with anti-cavitation check valve

BU - Polyacrylate drive shaft seal

CT - Cast iron housing , shuttle valve and orificed back pressure valve set at 14.8-16.2 bar [215-235 lbf/in²], 1.0-1.5 gal/min flow to case , and 2X M12 X 1.5 metric O-ring diagnostic ports (position 9 should have "0")

[12][13] Paint

0A - Primer, (std.)

0B - Black Paint, (std.)

[14] Identification

0 - Standard, (std.)

[15] Design Code

B - Valve Plate

Model 74315, 74318 and 74328 Fixed Displacement Motor

Output Shafts

Used for all 743XX Models

(Code position 4, 5)

Spline Shaft

Selection AA

Maximum Torque on Shaft
209.3 N•m [1,852 lbf•in]

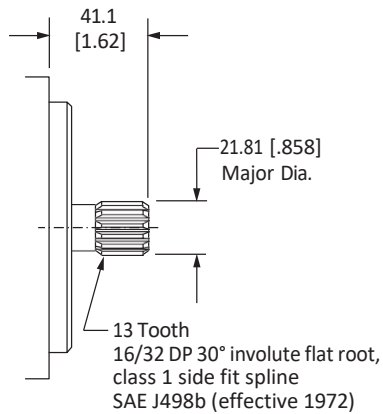

Spline Shaft

Selection AB

Maximum Torque on Shaft
337.5 N•m [2,987 lbf•in]

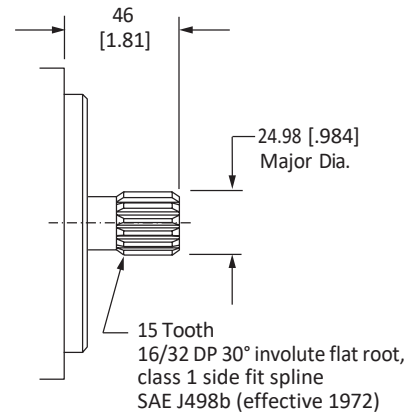

Straight Shaft

Selection AD

Maximum Torque on Shaft
337.5 N•m [2,987 lbf•in]

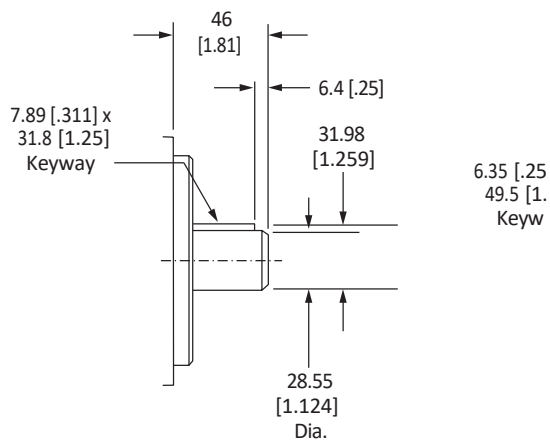

Spline Shaft

Selection BF

Maximum Torque on Shaft
209.3 N•m [1,852 lbf•in]

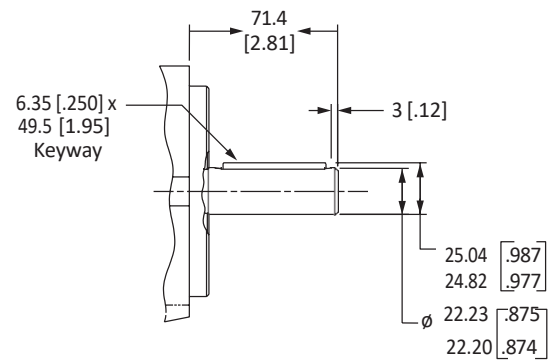

Note: Dimensions are in millimeters [inches], unless otherwise specified.

Model 74315, 74318 and 74328 Fixed Displacement Motor

Installation Drawings

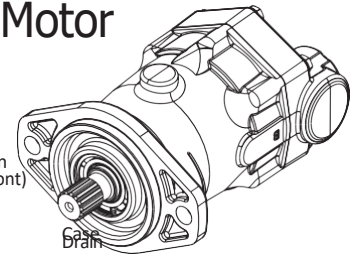

Opposite Side Porting (Code position 6, selection A or B)

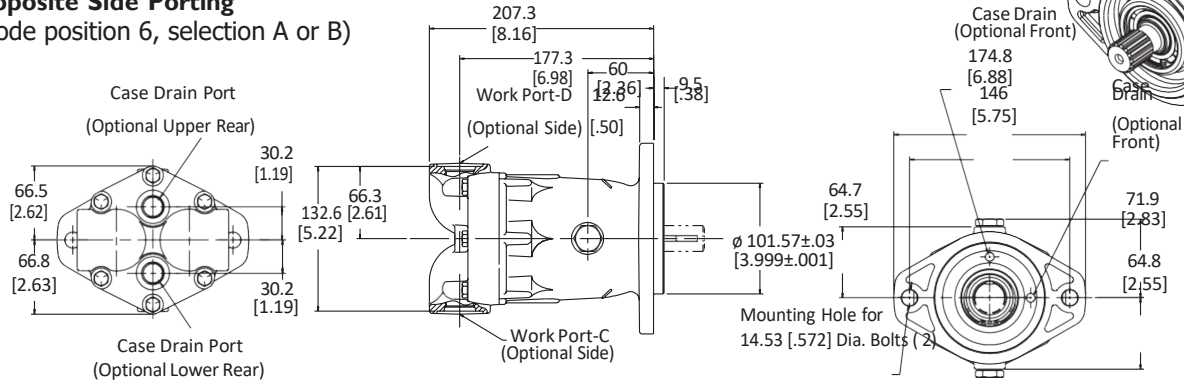

Rear Porting (Code position 6, selection C)

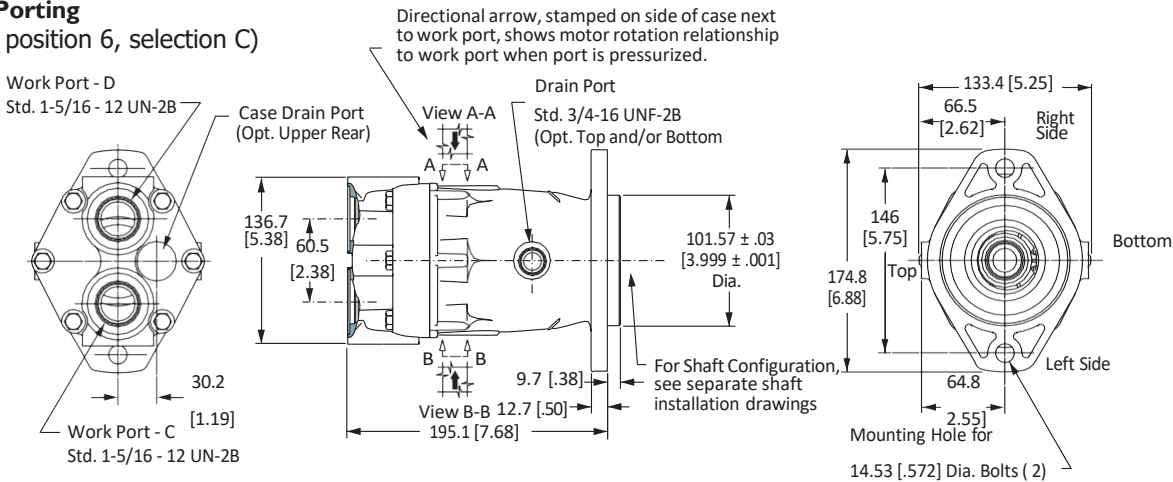

Same Side Porting (Code position 6, selection D)

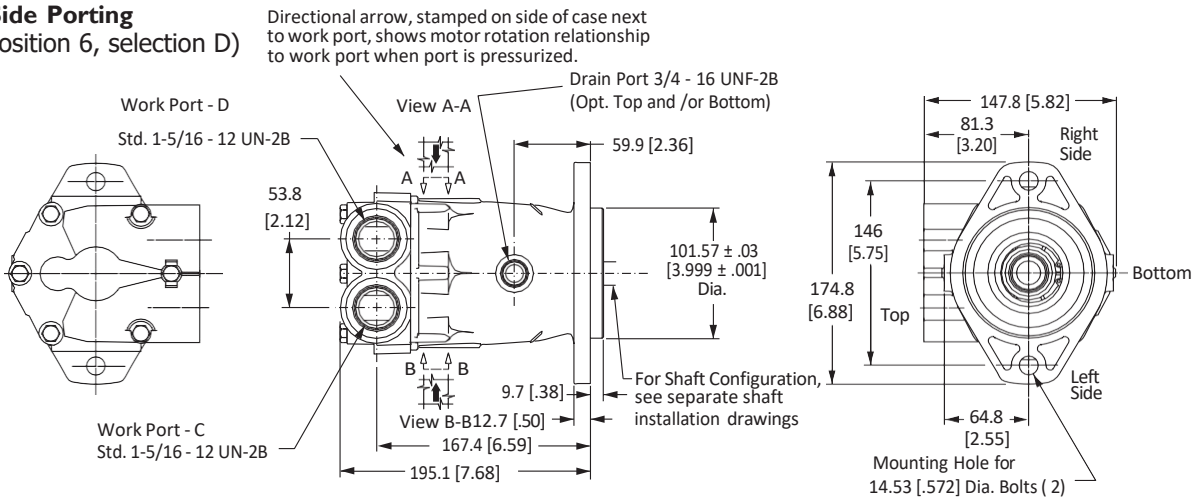

TYPE OF PORT	SIZE AND DESCRIPTION
Work Port	1- 1/16 - 12 UN-2B SAE O-ring
	1- 5/16 - 12 UN-2B SAE O-ring
	M33 X 2 Metric O-ring
	G1 BSPP Straight thread
Drain Port	3/4 - 16 UNF-2B SAE O-ring
	7/8-14 UNF-2B SAE O-ring
	9/16 -18 UNF-2B SAE O-ring
	M18 X 1.5 Metric O-ring port G 38 BSPP Straight Thread

Note: All ports are SAE (J1926) O-ring ports. Dimensions are in millimeters [inches], unless otherwise specified.

Installation Drawings

**Same Side Porting with
Through shaft for brake mounting**
(Code position 6, selection D)
(Code position 8, selection 3)

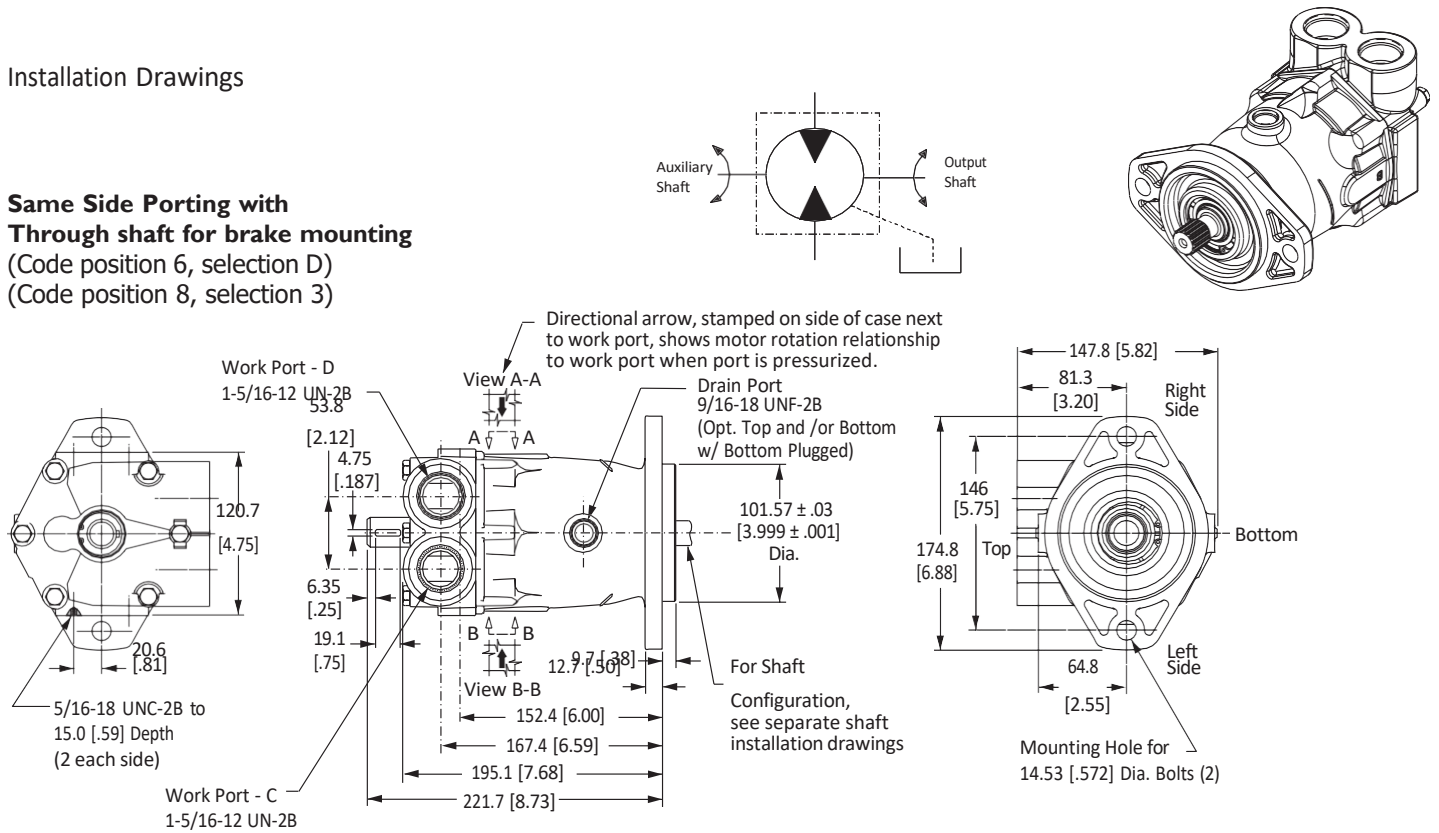

TYPE OF PORT	SIZE AND DESCRIPTION
Work Port	1- 1/16 - 12 UN-2B SAE O-ring
	1- 5/16 - 12 UN-2B SAE O-ring
Drain Port	3/4 - 16 UNF-2B SAE O-ring
	7/8-14 UNF-2B SAE O-ring
	9/16 - 18 UNF-2B SAE O-ring
	M18 X 1.5 Metric O-ring
	G 3/8 BSPP straight Thread

743XX Motor

Anti-Cavitation Check Valve

Position 10, 11

Anti-Cavitation check valve is used for application such as Fan drive control. When there is a need to reduce the motor speed during operation, the pump flow to motor is reduced, but due to the inertia of the load (Fan), the motor still runs at certain high speed. It is for a very short period of time.

This causes motor to suck more oil from pump port and may lead to cavitation in pump high pressure line.

To avoid this, oil from the low pressure side of the motor is circulated to the its high pressure side. A check valve is installed to connect the two motor ports.

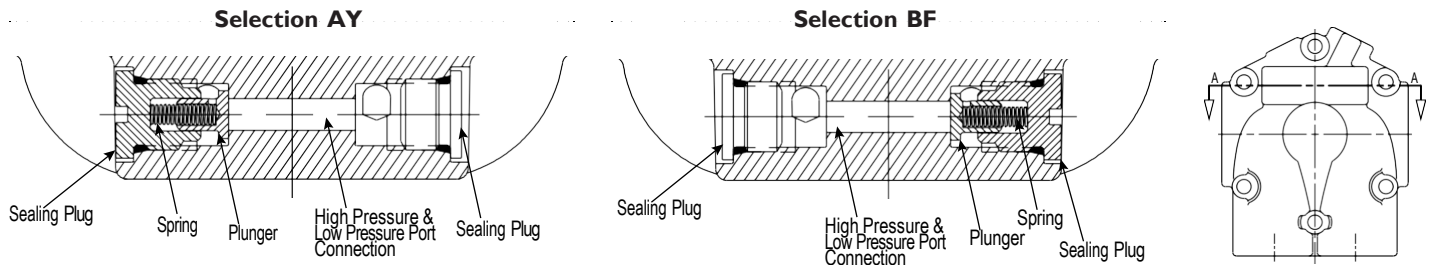

Note: All ports are SAE (J1926) O-ring ports. Dimensions are in millimeters [inches], unless otherwise specified.

Model 74315, 74318 and 74328 Fixed Displacement Motor

Installation Drawings

Same Side Porting with Shuttle Valve and Charge Pressure Relief Valve
(Code position 10, 11 selection AD or AM)

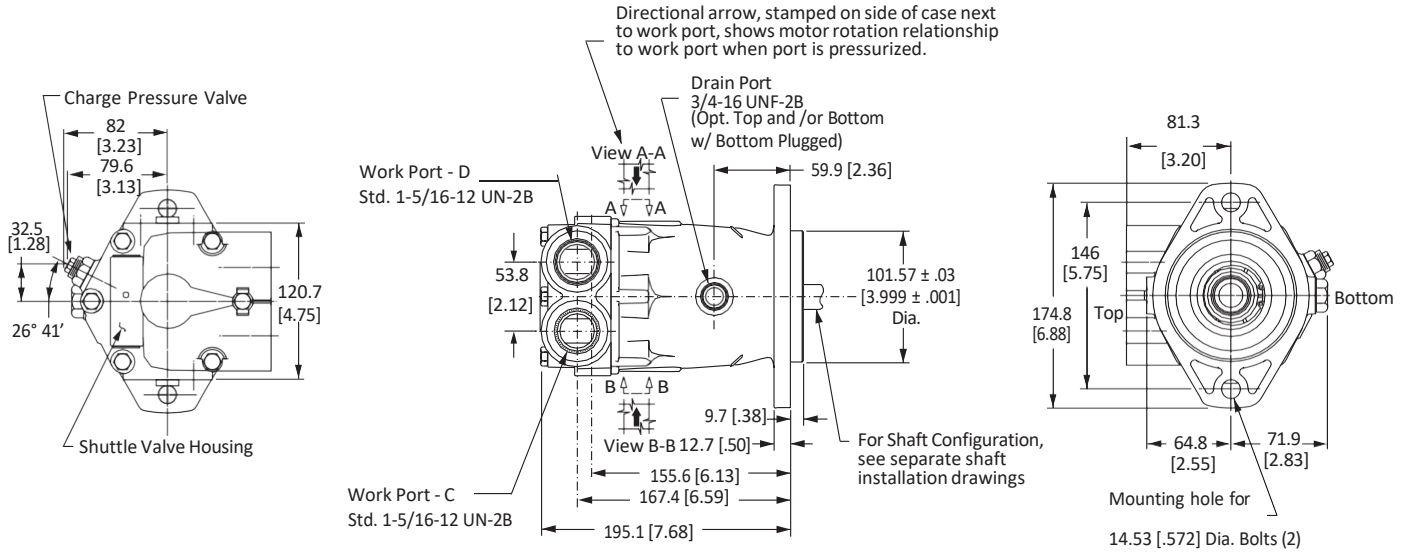
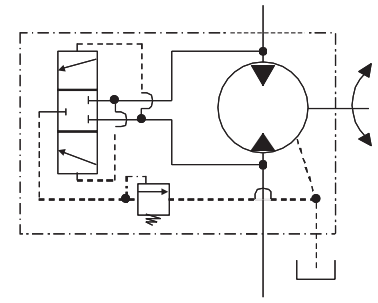

TYPE OF PORT	SIZE AND DESCRIPTION
Work Port	1- 1/16 - 12 UN-2B SAE O-ring
	1- 5/16 - 12 UN-2B SAE O-ring
	M33 X 2 Metric O-ring
Drain Port	3/4 - 16 UNF-2B SAE O-ring
	7/8-14 UNF-2B SAE O-ring
	9/16 - 18 UNF-2B SAE O-ring
	M18 X 1.5 Metric O-ring port

Model 74315, 74318 and 74328 Fixed Displacement Motor

Shuttle Valve and Charge Pressure Relief Valve:

The shuttle and charge pressure valve work together to bypass closed loop oil. This allows the oil to be cooled, filtered, and returned to tank.

The circuit shows the shuttle valve and the charge pressure relief valve. Stroking the variable displacement pump creates system pressure on one side of the closed loop. This system pressure shifts the shuttle valve, opening the low pressure side of the loop to the second charge pressure relief valve. The charge pressure relief valve will now close as it has a higher valve setting. This closed valve will now cause total charge pump flow to enter the low pressure side through the lower check valve. The charge pump flow first replenishes the lubrication fluid lost from the closed loop. The remaining charge flow will then displace an equivalent volume of hotter fluid in the low pressure side. This displaced fluid passes through the shuttle valve and second charge pressure relief valve directly into the motor case, pump case, heat exchanger and back into the reservoir. By continuously replacing the hotter loop fluid with the cool fluid, the closed loop temperature is stabilized.

The shuttle valve flow is listed below in relationship to the charge pressure valve setting.

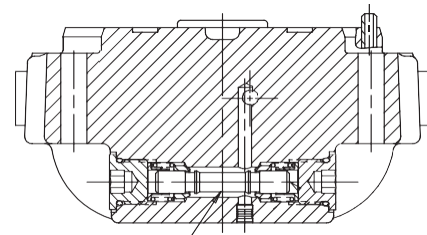

Shuttle Valve

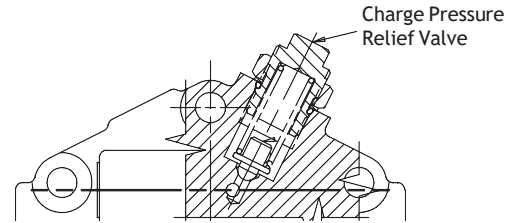

Charge Pressure Relief Valve

CHARGE PRESSURE	FLOW	CODE SELECTION
10 to 12 bar [145 to 175 lbf/in ²]	5.68 to 9.46 l/m [1.5 to 2.5 gal/min]	AM
15 to 17 bar [220 to 250 lbf/in ²]	9.46 to 13.25 l/m [2.5 to 3.5 gal/min]	AD

Note: All ports are SAE (J1926) O-ring ports.
Dimensions are in millimeters [inches], unless otherwise specified.
For other charge pressure options please contact Danfoss representative

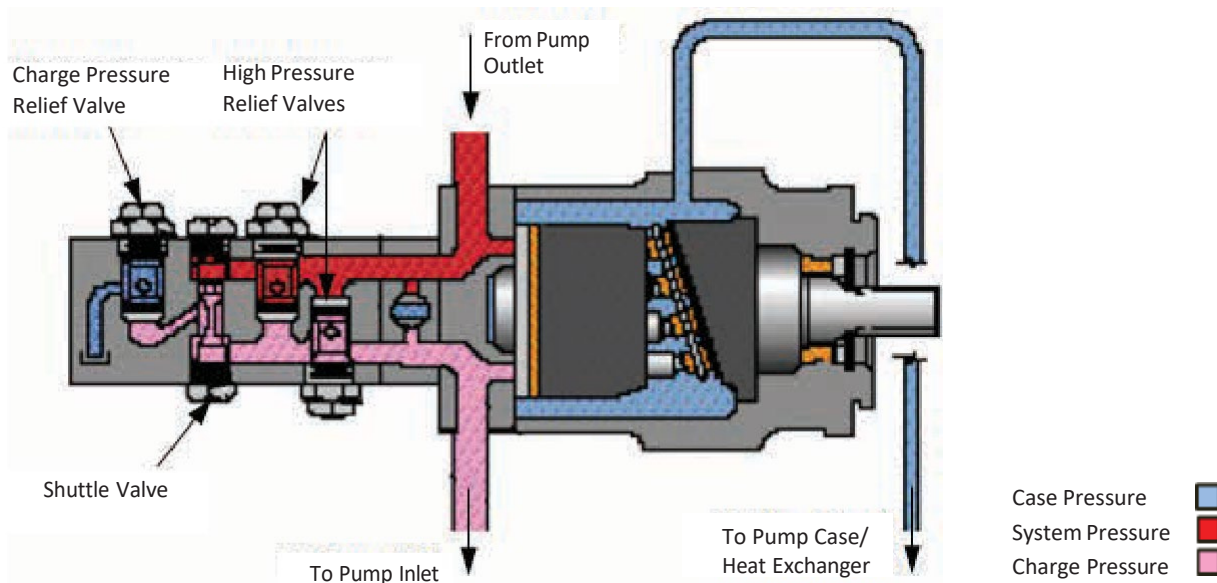

Model 743XX Fixed Displacement Motor

Speed Sensor

(Code Position 10,11 selection AP)

Fixed motors are available with a speed sensor for measurement of motor output speed. This sensor will operate with a supply voltage of 4.5 to 15 Vdc, and requires a current of 12 mA at 5.0 Vdc (minimum) under no load. Refer following table for specifications: The sensor is available with a Packard Electrical Weather-Pack series.

The Hall Effect speed sensor is compatible with the mobile vehicle electrical systems and gives a reliable digital on/off signal over a wide speed and temperature range.

The rugged design is fully protected against reverse polarity or short circuit hook up. A built-in pull up resistor simplifies installation with control systems.

The motor speed sensor is a factory installed option.

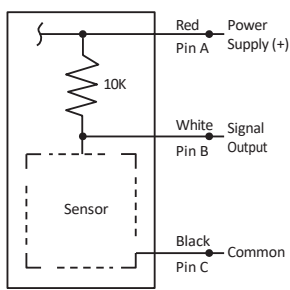

Output Circuit Wiring Instructions

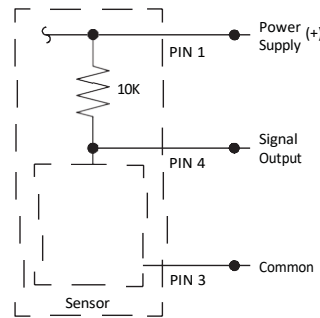
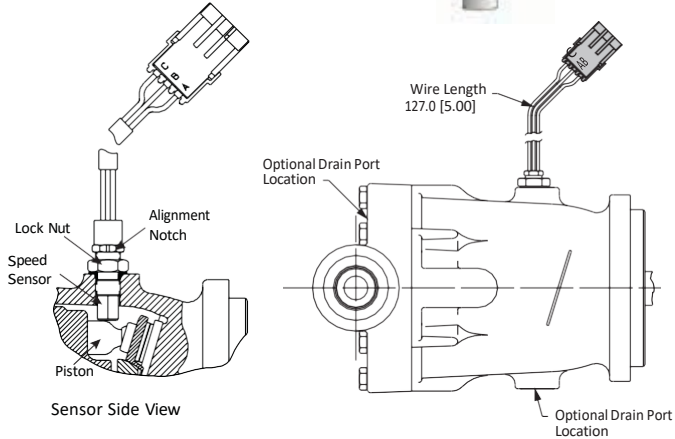
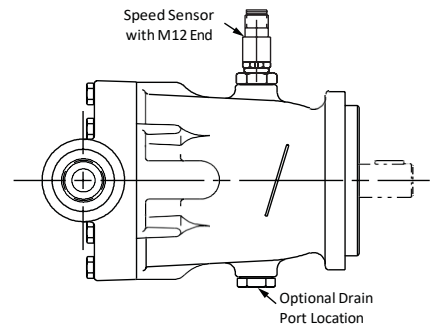
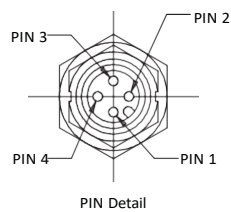
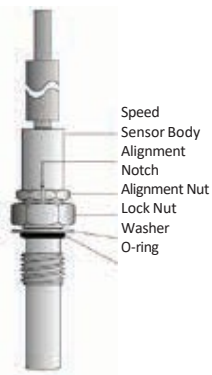

Output Circuit Wiring Instructions

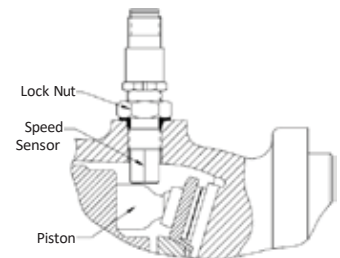

SPECIFICATION

Supply Voltage	(Vs) 8 to 28 Volt DC
Supply Current	(Is) 20 mA (including internal pull up resistor)
Switching Frequency	7 to 3K Hz
Output Voltage High	Supply Voltage minus 0.5 Volt DC min. (Open Collector with 10k Ω pull up resistor)
Output Voltage Low	(Vol) 0.5 Volt DC Maximum at 10 mA
Min. Shaft Speed	50 RPM
Pulses per Revolution	9

CONNECTION REQUIREMENTS

Cable	18 AWG Irradiated PVC-single conductor wires standard OR equivalent wall (Refer SAE J-1128 Type GXL) 1 black, 1 red, 1 white.
Packard Electric Weather Pack Series	Mating female connector assembly #12110293 and # 12048074 terminal (3X).

Speed Sensor - M12

Code position 10, 11 selection CA

Danfoss has developed a speed sensor, based on the field proven technology of our Hall Effect and Magnetic sensor.

Output – Digital signals from NPN transistors (open collector output with internal 10K pull up resistors).

This sensor has reverse polarity protection, short circuit protection, load dump protection, and EMC (Electrical Magnetic Capability) protection (the customer should qualify the EMC protection in their specific application)

Supply Voltage: 8 to 24 Volt DC (compatible with 12V vehicle conditions)

SPECIFICATION

Supply Voltage	(Vs) 8 to 28 Volt DC
Supply Current	(Is) 20 mA (including internal pull up resistor)
Switching Frequency	7 to 3K Hz
Output Voltage High	Open Collector with 10k Ω pull up resistor
Output Voltage Low	(Vol) 0.5 Volt DC Maximum at 10 mA
Min. Shaft Speed	50 RPM
Pulses per Revolution	9

CONNECTION REQUIREMENTS

Mates with DC Micro connectors or equivalent:	Turk Eurofast WKCV 4T cable
	Brad Harrison Micro-Change single keyway plugs
	Lumberg Micro style 12mm DC connector

Model 746XX Fixed Displacement Motor

2 Bolt SAE B-B Mount

82.6 cm³/r [5.04 in³/r] Displacement

Single Motor - Product Number

7 4 6 2 4 - D A H
 A B C

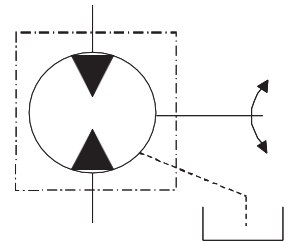

Identification numbers – Fixed Displacement Motor - Closed Circuit
 Stamped on each unit.

A – Product Number Description

74624 = 82.6 cm³/r [5.04 in³/r] (W/Bearing Upgrade)

74644 = 82.6 cm³/r [5.04 in³/r] Through Shaft for Brake Mount
 (W/Bearing Upgrade)

B – Rotation

D = Dual

C – Sequential Letter



Serial Number Code

10 05 06 XXX 1 000

Last Two Digits of Year Built. (10 for 2010 etc.)

Month Built (two digits)

Day Built (two digits)

Specific Number of the Pump

Shift Number

Manufacturing Cell

TYPICAL PRODUCT NUMBER	MODEL CODE
74624-DAH	AAZAAA0000A0B
74624-DAV	AAZAABB0000A0B
74644-DAJ	AAZAABBA000A0B
74624-DAB	AAZADAA0000A0B
74644-DAJ	AAZAABBA000A0B

SPECIFICATIONS	MODEL 74624/74644
Maximum Displacement	82.6 cm ³ /r [5.04 in ³ /r]
Maximum Rated Speed	1500 RPM
Nominal Pressure Rating †	250 bar [3626 lbf/in ²]
Peak Pressure Rating ††	265 bar [3900 lbf/in ²]
Input Flow at Rated Speed and Pressure	150.0 l/min [33 GPM]
Output Power at Rated Speed and Pressure	52 kW [70 hp]
Output Torque at Rated Speed and Pressure	329 N•m [2910 lbf•in]
Continuous Allowable Case Pressure	7 bar [100 lbf/in ²]
Continuous Inlet Temperature	107° C [225° F]
Weight/Single Motor (approximate)	10.9 kg [24 lbs]

† Nominal Pressure: Max delta system pressure at which component fatigue does not occur (motor life estimated by bearing life).

†† Peak Pressure: Max operation pressure which is permissible for a short duration of time (t < 1 sec).

Model 746XX Fixed Displacement Motor

The dual piston design with combination of solid and hollow pistons which gives displacement of $82.6 \text{ cm}^3/\text{r}$, provides power dense package. Uses lightweight aluminum housing, end cover with rear & top side working ports. Numerous

output shafts with through drive capabilities for brake mounting. End cover houses main ports, gauge ports.

Attached cross section view shows major components of the motor.

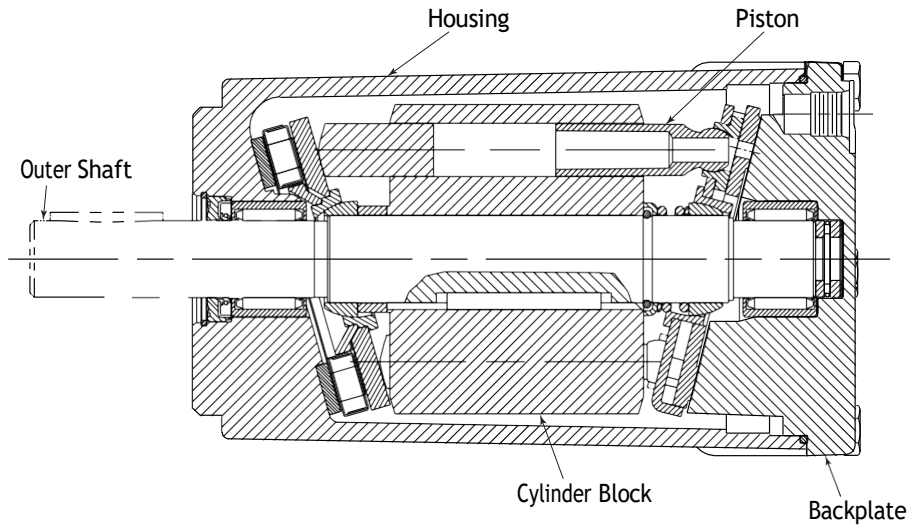

Model 746XX Fixed Displacement Motor

82.6 cm³/r [5.04 in³/r] Displacement

High torque fixed displacement piston motors are specified by the following model code. Once a motor is built from the model code, a product number will be assigned to that

configuration. Make sure all positions are selected within the 14 digit code for each motor.

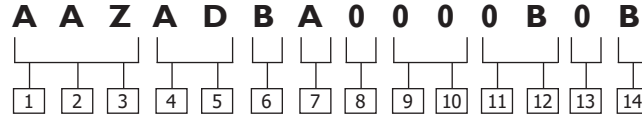

[1][2][3] Code Title

AAZ - 82.6 cm³/r [5.04 in³/r] High Torque Fixed displacement piston motor frame size

[4][5] Output Shaft

AA - Straight Shaft, dia. 25.4[1.00], keyway 6.35[.250] X 38.1[1.50], shaft extension 63.5 [2.50] (key included), (std.)
AD - 15 Tooth 16/32 spline with snap ring groove, shaft extension 46 [1.81], (std.)
AE - 13 Tooth 16/32 spline, shaft extension 41.1 [1.62], (std.)

[6] Main Port, Size, & Location

A - 1-1/16-12 UN-2B straight thread O-ring ports- rear, (std.)
B - 1-1/16 UN-2B straight thread O-ring ports same side, top, (opt.)

[7] Drain Port, Size, & Location

A - 9/16-18 UNF-2B straight thread O-ring port - Horizontal top rear of unit, (std.)
B - 9/16-18 UNF-2B Straight thread O-ring port – Vertical top rear of unit, (opt.)
D - Through drain into mounting flange (Front)

[8] Auxiliary Mounting Features (rear)

0 - No Auxiliary Mounting Feature - Model 74624, (std.)
A* - Straight through shaft, dia. 25.4 [1.00], with keyway 6.35 x 25.4 [.250 x 1.00], Shaft length from mounting flange 274.3 [10.80] (key included); 2 mounting holes 5/16- 18 UNC-2B Thd, 13.3 [.53] min. full thread (bottom rear of unit) - Model 74644, (opt.)
B - 15 Tooth 16/32 spline, with .375-16 UNC-2B thread, 18.3 [.72] min full thread, shaft length from mounting flange 274.3 [10.80]; 2 mounting holes .3125-18 UNC-2B thread, 13.3[.53] min full thread (Bottom rear of unit)

***Note:** Requires the selection of same side porting only. (opt.)

[9][10] Special Features

00 - No Special Features, (std.)

[11][12] Paint

0A - Primer, (std.)
0B - Black Paint, (std.)

[13] Identification

0 - Standard, (std.)

[14] Design Code

B - Bearing Upgrade

Note: All ports are SAE (J1926) O-ring ports.

Model 746XX Fixed Displacement Motor

Output Shaft Options

(Code Position 4,5)

Used for all 746XX models

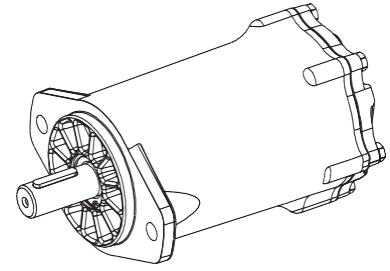

Straight Shaft

(Code selection AA)

Maximum Torque on Shaft.
337.5 N•m [2,987 lbf•in]

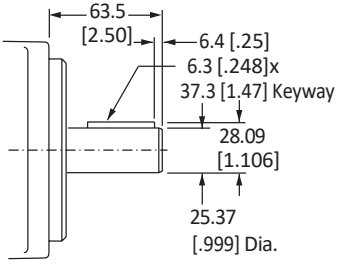

Spline Shaft

(Code selection AD)

Maximum Torque on Shaft.
337.5 N•m [2,987 lbf•in]

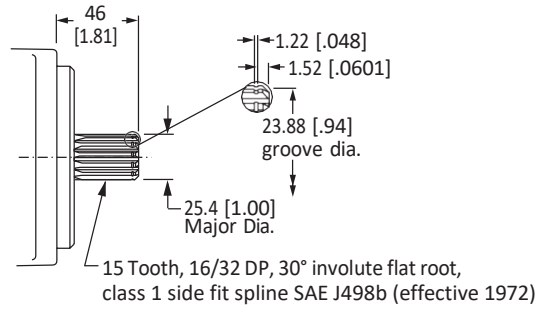

Spline Shaft

(Code selection AE)

Maximum Torque on Shaft.
209.3 N•m [1,852 lbf•in]

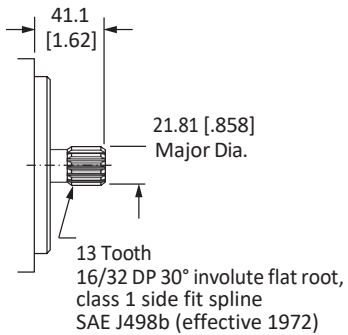

Model 74624 Fixed Displacement Motor

Installation Drawings

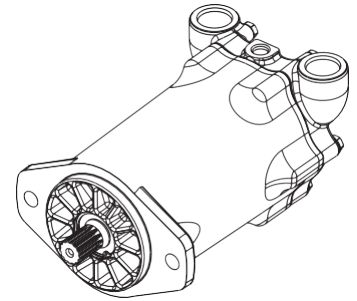

Rear Porting

(Code position 6, selection A)

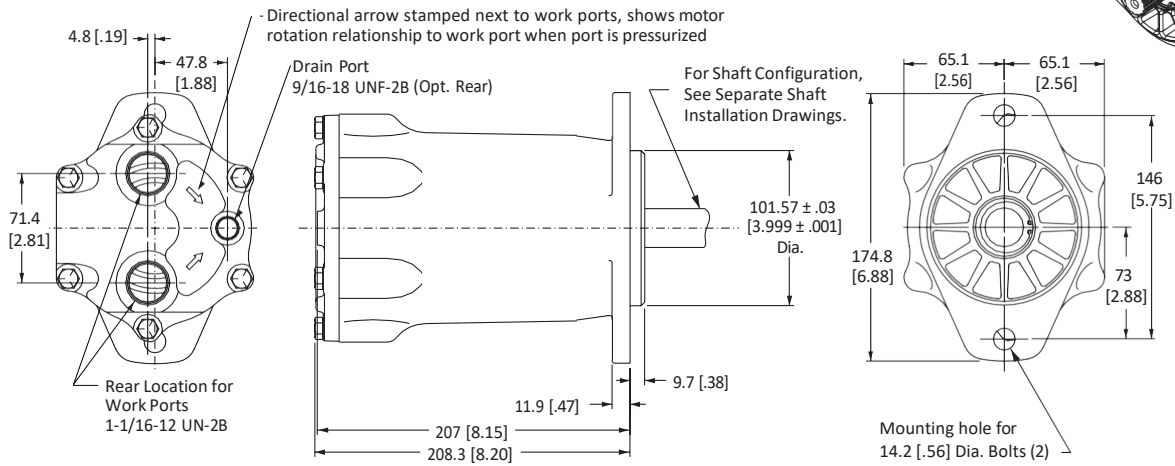

Same Side Porting

(Code position 6, selection B)

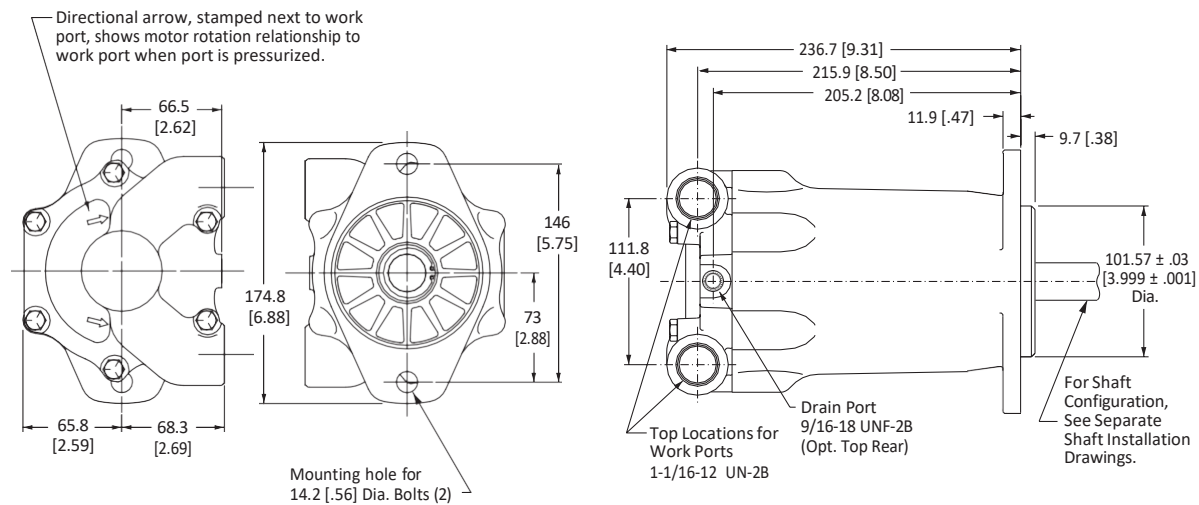

Through Shaft for Brake Mounting

(Code position 8, selection A or C)

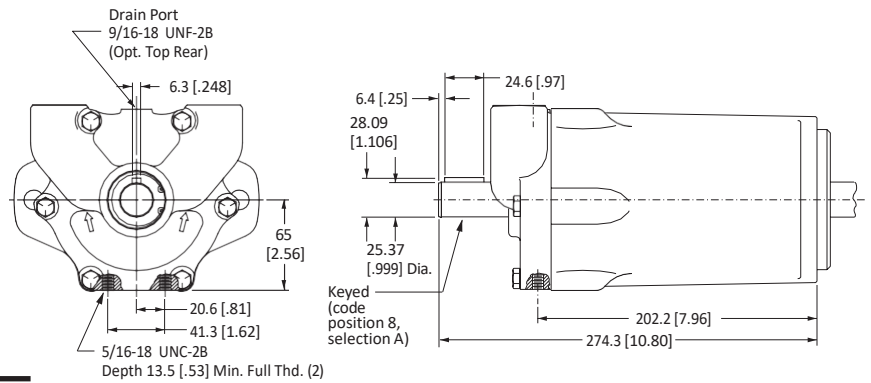

TYPE OF PORT	SIZE AND DESCRIPTION
Work Port	1- 1/16 - 12 UN-2B SAE O-ring
Drain Port	9/16 - 18 UN-2B SAE O-ring

15 Tooth, 16/32 DP, 30° involute flat root class 1 side fit spline SAE J498b (effective 1972) (code position 8, selection C)

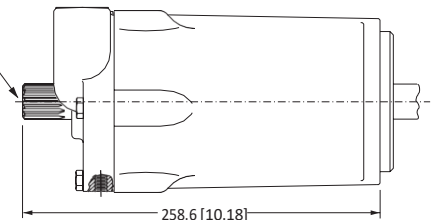

Note: All ports are SAE (J1926) O-ring ports. Dimensions are in millimeters [inches], unless otherwise specified.

Model 74624 Fixed Displacement Motor

Features & Benefits

- Compact - Ease of Installation
- Numerous Options - Shafts, Ports, Shuttle Valves, speed pickup
- Displacement range: 7.3cc (0.45cid) to 49.2cc (3.0cid)
- Hydraulic De-stroke, Servo Control for remote control

2 Bolt SAE "B" Mount - 71392 Series

40.6 to 21.0 cm³/r [2.48 to 1.28 in³/r] Displacement



2 Bolt SAE "B" Mount - 72450 Series

40.6 cm³/r [2.48 in³/r] Displacement

49.2 cm³/r [3.0 in³/r] Displacement



40.6 to 21.0 cm³/r [2.48 to 1.28 in³/r] Displacement

Identification numbers – Fixed Displacement Motor - Closed Circuit
Stamped on each unit.

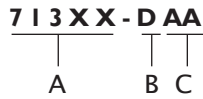

A – Product Number Description

71302 / 71392 = Variable Motor 40.6 cm³/r [2.48 in³/r]

B – Rotation

D = Dual

C – Sequential Letter

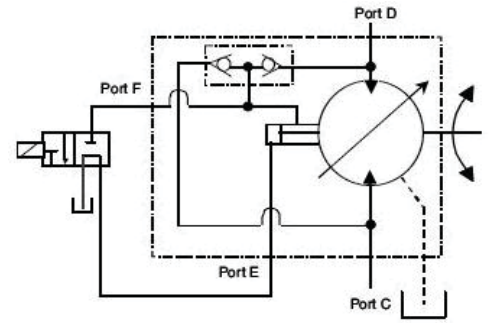

Serial Number Code

10 05 06 XXX I 000

Last Two Digits of Year Built. (10 for 2010 etc.)

Month Built (two digits)

Day Built (two digits)

Specific Number of the Pump

Shift Number

Manufacturing Cell

TYPICAL PRODUCT NUMBER	MODEL CODE
71392-DAE	AAMGA110M000A0C
71392-DAC	AAMGA210D000A0C
71392-DAJ	AAMGA210H000A0C
71392-DAB	AAMGA260H000A0C

SPECIFICATIONS	MODEL 71302/71392
Maximum Displacement	40.6 to 21.0 cm ³ /r [2.48 to 1.28 in ³ /r]
Maximum Rated Speed	3600 RPM at 17° Control Angle 4500 RPM at 9° Control Angle
Nominal Pressure Rating †	350 bar [5076 lbf/in ²]
Peak Pressure Rating ††	370 bar [5400 lbf/in ²]
Input Flow at Rated Speed and Pressure	175.71 l/min [38.65 GPM] at 17° Control Angle
Output Power at Rated Speed and Pressure	85.30 kW [114.50 hp] at 17° Control Angle
Output Torque at Rated Speed and Pressure	226.27 N•m [2004.54 lbf•in] at 17° Control Angle
Continuous Allowable Case Pressure	1.7 bar [25 lbf/in ²]
Continuous Inlet Temperature	107°C [225°F]
Weight/Single Motor (approximate)	9.5 kg [21 lbs]

† Nominal Pressure: Max delta system pressure at which component fatigue does not occur (motor life estimated by bearing life).

†† Peak Pressure: Max operation pressure which is permissible for a short duration of time (t < 1 sec).

Working Principle

Axial piston motor uses a variable cam / swash plate to change the motor displacement. Shuttle valve mounted on end cover, ports high pressure oil from either side to the control piston. When the control valve is energized, ports E and F are connected and therefore contain equal pressure. The area differential (rod side vs back side of the piston) creates a force that pushes the piston to the right, taking the motor to max displacement. High side system pressure (not charge pressure) must be used to actuate the cylinder. Most of the flow from the pump goes to turn the rotating kit, leaving only a small amount of flow to go across the shuttle valve and into the cylinder. Therefore, there is no issue with too much flow going into the cylinder and having nowhere to go. Schematic shows motor in de-stroked condition (min cam).

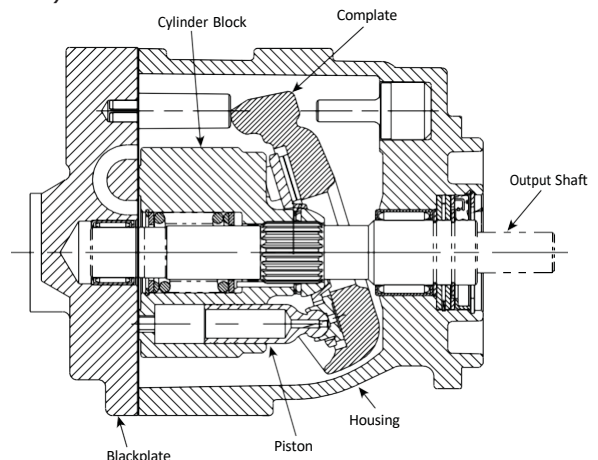

40.6 cm³/r [2.48 in³/r] Displacement

Variable displacement piston motors are specified by the following model code. Once a motor is built from the model code, a product number will be assigned to that configuration.

Make sure all positions are selected within the 15 digit code for each motor.

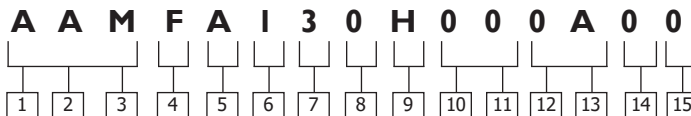

1 2 3 Code Title

AAM - 40.6 cm³/r [2.48 in³/r]
Variable displacement
piston motor frame size
2 Bolt B-SAE

4 Control Options

F - Hydraulic De-stroke
Control, Remote Port Down -
Model 71392, (opt.)
G - Hydraulic De-stroke Control,
Remote Port Up - Model
71392, (opt.)

5 Output Shaft

A - 13 Tooth 16/32 spline,
shaft extension 41.1 [1.62],
(std.)
B - 13 Tooth 16/32 spline,
with snap ring groove, shaft
extension 41.1 [1.62], (opt.)

6 Main Port, Size & Location

1 - 1 1/16-12 UN-2B straight
thread O-ring ports - Rear,
(std.)
2 - 1 1/16-12 UN-2B straight
thread O-ring ports - Oppo-
site Sides, (std.)

7 Drain Port, Size & Location

1 - 9/16-18 UNF-2B straight
thread O-ring port - Right
Side, (std.)
2 - .750-16 UNF -2B SAE O-
ring port - right side
3 - 9/16-18 UNF-2B straight
thread O-ring port - Rear of
Backplate, (opt.)
6 - 9/16-18 UNF-2B straight
thread O-ring port - Top,
(opt.)

8 Auxiliary Mounting Features (rear)

0 - No Auxiliary Mounting
Feature, (std.)
I* - 13 Tooth 16/32 Ext.
Tapered spline with tapped
hole, bottom pad with 5/16-
18 UNC- 2B mounting holes,
(opt.)
* Requires the selection of opposite
side porting only

9 Min-Max Displacements & Control Angles

0 - 00.0-40.6 cm³/r [0.00-2.48
in³/r] minimum - 0°
maximum -17°
D - 17.9 to 40.6 cm³/r [1.09
to 2.78 in³/r], minimum 7° 40'
maximum 9° 0' (std.)
G - 20.5-40.6 cm³/r
[1.25-2.48 in³/r] minimum 8°
45' maximum 17° 0'
(std.)
H - 21.0 to 40.6 cm³/r [1.28
to 2.48 in³/r], minimum 9° 0'
maximum 17° 0'
(std.)
Z - 40.6 cm³/r [2.48 in³/r]
17 deg 0 min maximum
minimum displacement and
control angle determined by
2.6 [.102] shim thickness

10 11 Special Features

00 - No special feature, (std.)
AA - No V Notches

12 13 Paint

0A - Primer, (std.)
0B - Black Paint, (std.)

14 Identification

0 - Standard, (std.)

15 Design Code

C - Valve plate

Note: All ports are SAE (J1926)
O-ring ports.

Installation Drawing

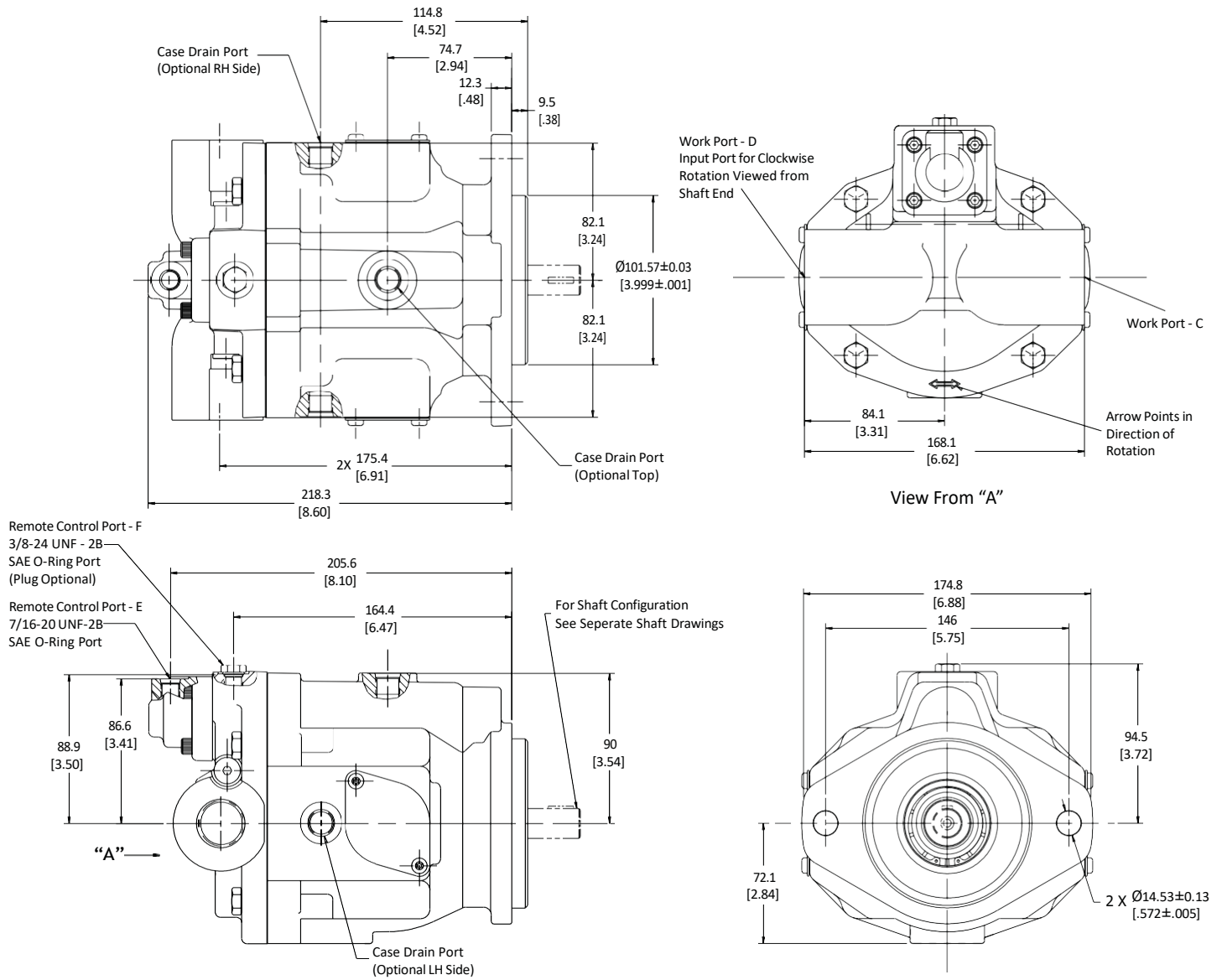

TYPE OF PORT	SIZE AND DESCRIPTION
Work Port	1- 1/16 - 12 UN-2B SAE O-ring
Drain Port	9/16 - 18 UN-2B SAE O-ring

Note: All ports are SAE (J1926) O-ring ports. Dimensions are in millimeters [inches], unless otherwise specified.

Model 71392 Variable Motor

Control Options and Output Shafts

Hydraulic De-stroke Control

(Code position 4, selection F or G)

The Hydraulic De-stroke Control feature allows the operator to control the motor without any mechanical linkage to the motor. A normally closed valve is required to provide maximum displacement to the motor. The valves must be rated for maximum system pressure.

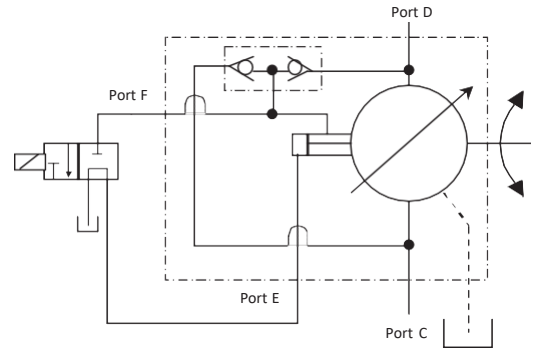

Control Port up

(Code position 4, Selection G)

Control Port Down

(Code position 4, Selection F)

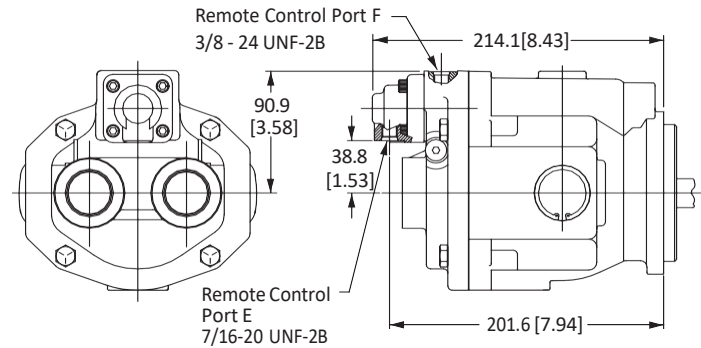
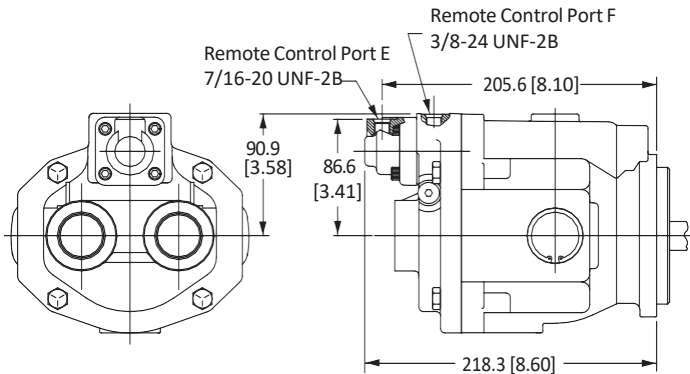

Output Shafts

(Code Position 5)

Selection A

Maximum Torque on Shaft
209.3 N•m [1,852 lbf•in]

Selection B

Maximum Torque on Shaft
209.3 N•m [1,852 lbf•in]

Selection D

Maximum Torque on Shaft
337.5 N•m [2,987 lbf•in]

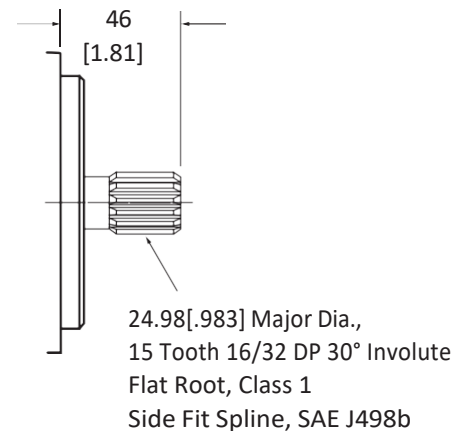
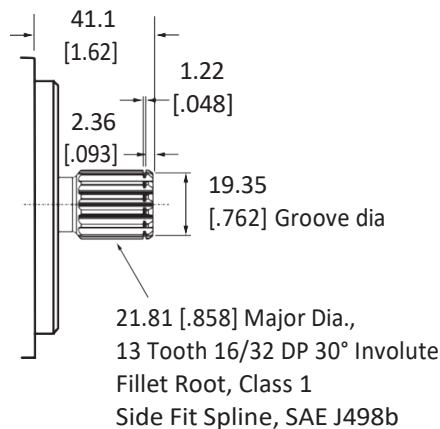
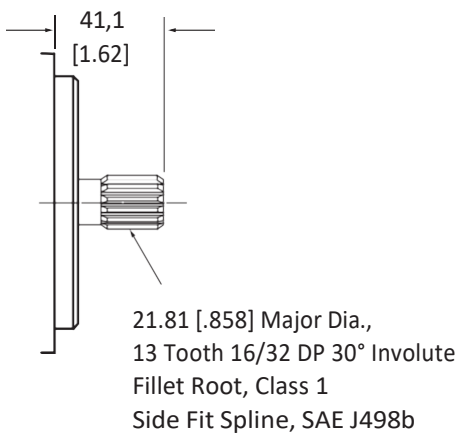

Note: All ports are SAE (J1926) O-ring ports. Dimensions are in millimeters [inches], unless otherwise specified.

Model 72450 Variable Servo Motor

Installation Drawings

Features

- SAE B- B, 2 Bolt Mount, Cradle Swashplate
- Bi-directional rotation
- Auxiliary through-drive shaft available for brake mounts
- Standard SAE splined shafts, Optional taper shafts
- Same Side ports
- System pressure guage ports
- Optional shuttle valve available



Identification numbers

Stamped on each unit.

A – Product Number Description

72450 = Variable Motor 40.6 cm³/r [2.48 in³/r],
49.2 cm³/r [3.00 in³/r]

B – Rotation

D = Dual

C – Sequential Letter

D – Design Code number

TYPICAL PRODUCT NUMBER	MODEL CODE
72450-DAG-02	ACTA0B200B0B000B
72450-DAM-02	ACTA0B200F0B040B

Serial Number Code

10 05 06 XXX 1 000

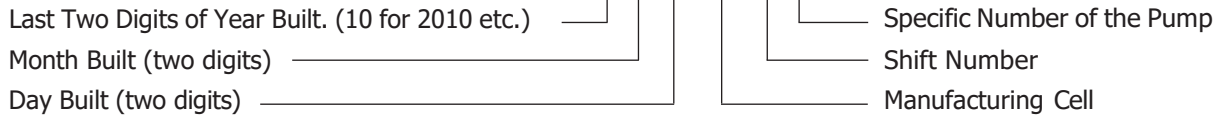

SPECIFICATIONS	MODEL 72450	MODEL 72450
Maximum Displacement	40.6 cm ³ /r [2.48 in ³ /r]	49 cm ³ /r [3.00 in ³ /r]
Maximum Rated Speed	4500 RPM at minimum stroke angle 3600 RPM at maximum stroke angle	4500 RPM at minimum stroke angle 3600 RPM at maximum stroke angle
Nominal Pressure Rating †	350 bar [5076 lbf/in ²]	280 bar [4061 lbf/in ²]
Peak Pressure Rating ††	372 bar [5395 lbf/in ²]	310 bar [4496 lbf/in ²]
Input Flow at Rated Speed and Pressure	175.71 l/min [38.65 GPM]	212.53 l/min [46.75 GPM]
Output Power at Rated Speed and Pressure	85.30 kW [114.50 hp]	82.36 kW [110.81 hp]
Output Torque at Rated Speed and Pressure	226.27 N•m [2004.54 lbf•in] at 17° Control Angle	218.47 N•m [1940 lbf•in] at 17° Control Angle
Continuous Allowable Case Pressure	1.7 bar [25 lbf-in ²]	1.7 bar [25 lbf-in ²]
Continuous Inlet Temperature	107° C [225° F]	107° C [225° F]

† Nominal Pressure: Max delta system pressure at which component fatigue does not occur (motor life estimated by bearing life).

†† Peak Pressure: Max operation pressure which is permissible for a short duration of time (t < 1 sec).

Model 72450 Variable Servo Motor

D1, D2 = Drain Ports
 A, B = Main Ports
 S1, S2 = Servo Control Port

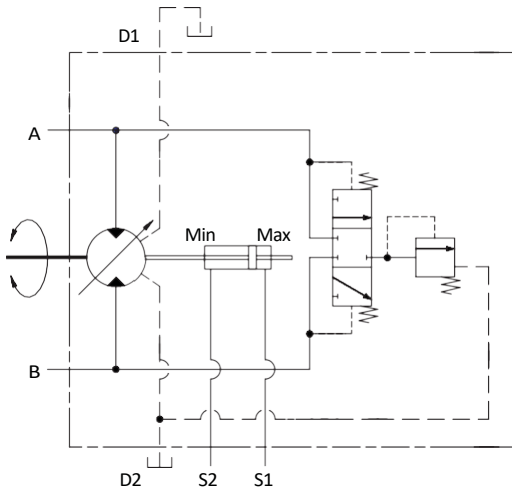

72450 Min - Max Displacement Servo Motor Schematic

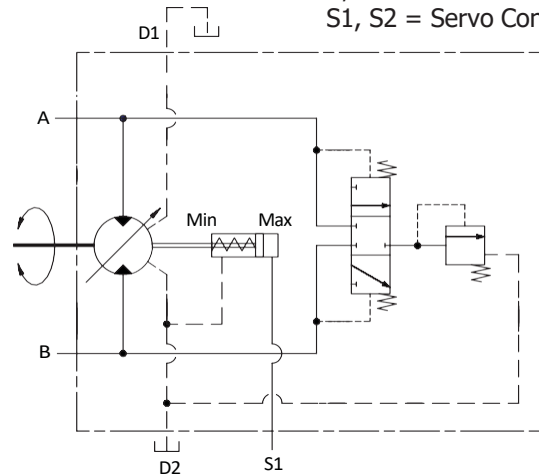

72450 Spring Biased Servo Motor Schematic

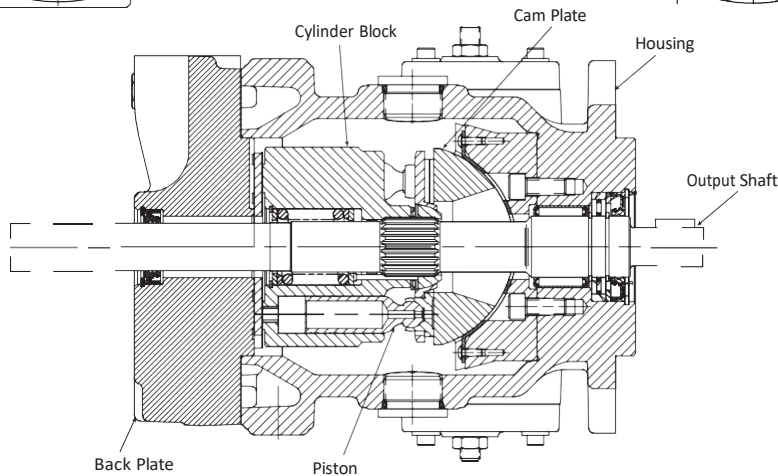
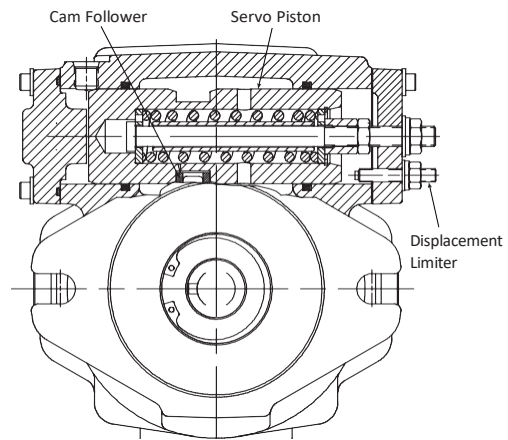
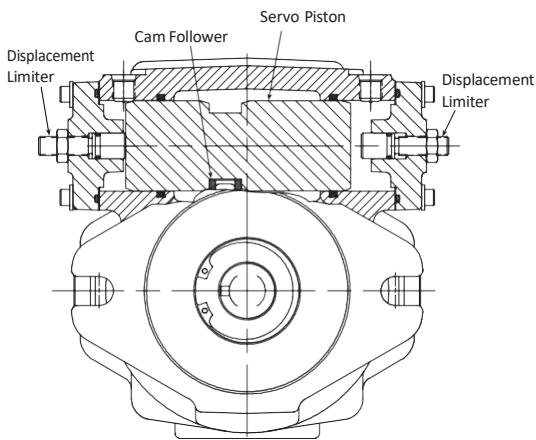

Working Principle

Servo piston mounted on top of the motor is connected to cam / swash plate and is used to change the cam angle. This in turn varies the motor displacement. Servo piston is actuated by means of external pilot pressure acting on either side of the piston.

There are two options available to actuate the piston, Min-Max position piston and spring biased servo piston.

In min-max displacement option, external pilot pressure moves the piston from minimum cam to maximum cam angle. No intermittent position is achievable. Displacement limiters are provided on both sides of the piston to set the maximum and minimum cam angle.

In spring biased servo piston design, external servo pressure works against servo spring force. As pressure inside servo cavity increases, servo piston moves towards maximum displacement and vice-versa.

Model 72450 Variable Servo Motor

Variable displacement piston motors are specified by the following model code. Once a motor is built from the model code, a product number will be assigned to that configuration.

Make sure all positions are selected within the 16 digit code for each motor.

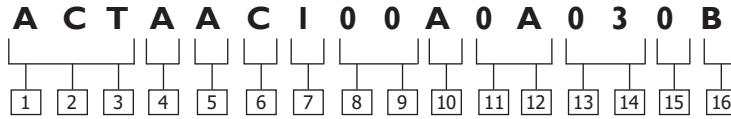

1 2 3 Code Title

ACT - 40.6 cm³/r [2.48 in³/r]
 Servo Controlled Variable Displacement piston motor
******* - 49.2 cm³/r (3.00 in³/r)
 Servo Controlled Variable Displacement motor.

Note: see position 13,14 special features.

4 Output Shaft

A - 13 Tooth 1/32 spline, Shaft extension 41.4 [1.62]
B - 13 Tooth 16/32 spline, with snap ring groove, shaft extension 41.1[1.62]
C - 15 Tooth 16/32 spline, shaft extension 46 [1.81]

5 Auxiliary Mounting Features (rear)

0 - No Auxiliary Mounting Features
A - Diameter 22.22 mm (.875 in) taper shaft

Output Shaft Options (Code Position 4)

Selection A
 Maximum Torque on Shaft
 209.3 N•m [1,852 lbf•in]

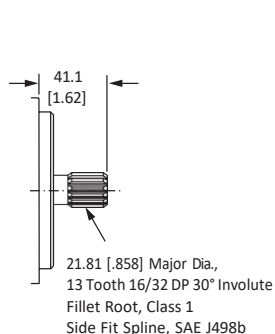

Selection B
 Maximum Torque on Shaft
 209.3 N•m [1,852 lbf•in]

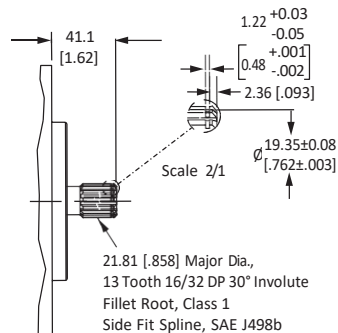

Selection C
 Maximum Torque on Shaft
 337.5 N•m [2987 lbf•in]

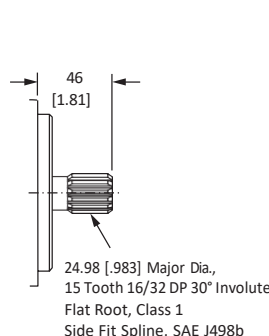

Auxiliary Mounting Features (Rear) (Code Position 5)

Taper Shaft Selection A
 Maximum through torque
 209.3 N-m [1852 lbf-in]

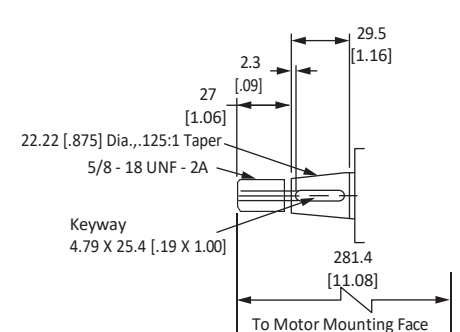

6 Drain Port, Size, & Location

A - 1-1/16-12 UN-2B SAE O-ring, left and right side
B - 1-1/16-12 UN-2B SAE O-ring, left and right side. Right side plugged.
C - 1-1/16-12 UN-2B SAE O-ring, left and right side. Left side plugged.

7 Main Port, Size, & Location

I - 1-5/16-12 UN-2B SAE O-ring (A&B) same side (right side)
2 - 1-5/16-12 UN-2B SAE O-ring (A&B) same side (left side)
4 - 1 1/16 -12 UN-2B SAE O-ring port (A & B) – same side (left side)
6 - Dash 12 STC Type II+ direct port (A & B) – left side

8 9 Control Assembly

00 - No control assembly Port plate control

10 Min-Max Displacements

3 - 13.5-40.6 cm³/r [0.82-2.48in³/r] 5 deg 48 minutes min - 17 deg 0 minutes max
A - 20.5-40.6 cm³/r (1.25-2.48 in³/r) 8° 45 minutes min. - 17° 0 minutes max.
D - 26.7-36.7 cm³/r [1.63-2.24 in³/r] 11 deg 20 minutes min - 15 deg 24 minutes max
F - 24.5-49.2 cm³/r [1.49-3.00 in³/r] 8° 34 minutes min. - 17° 0 minutes max.
L - 14.7-40.6 cm³/r [0.90-2.48 in³/r] 6 deg 20 minutes min - 17 deg 0 minutes max

11 12 Paint

0A - Primer, (std.)
0B - Black Paint, (std.)

13 14 Special Features

00 - None
03 - Shuttle valve and backpressure valve set 15.2-17.2 Bar (220-250 PSI) rear facing S1, S2 servo control ports
*****04**- Ref. code title
I I - Biased to maximum displacement ; rear facing s1 port only.
I 2 - 9.2 cm³/r [3.00 in³/r] rotating group; biased to maximum displacement ; rear facing s1 port only.

15 Customer Identification

0 - Standard, (std.)

16 Design Code

B - Danfoss assigns current design code, (std.)

Model 72450 Variable Servo Motor

Installation Drawings

Port Right Side

(Code Position 7, Selection 1)

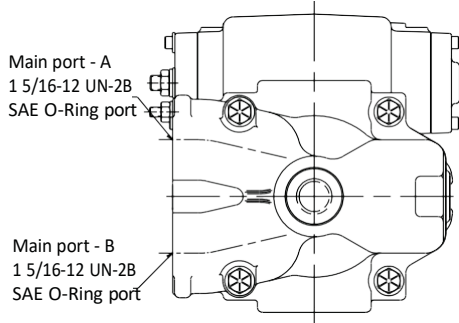

TYPE OF PORT	SIZE AND DESCRIPTION
Work Port (A, B)	1- 1/16 - 12 UN-2B SAE O-ring
	1- 5/16 - 12 UN-2B SAE O-ring
Drain Port (D1, D2, D3)	Dash 12 STC Type II + Direct Ports
	7/8-14 UNF - 2B SAE O-ring
Servo Control Pressure Port	1- 1/16 - 12 UN-2B SAE O-ring
	7/16 - 20 UN-2B SAE O-ring

Port Left Side

(Code Position 7, Selection 2)

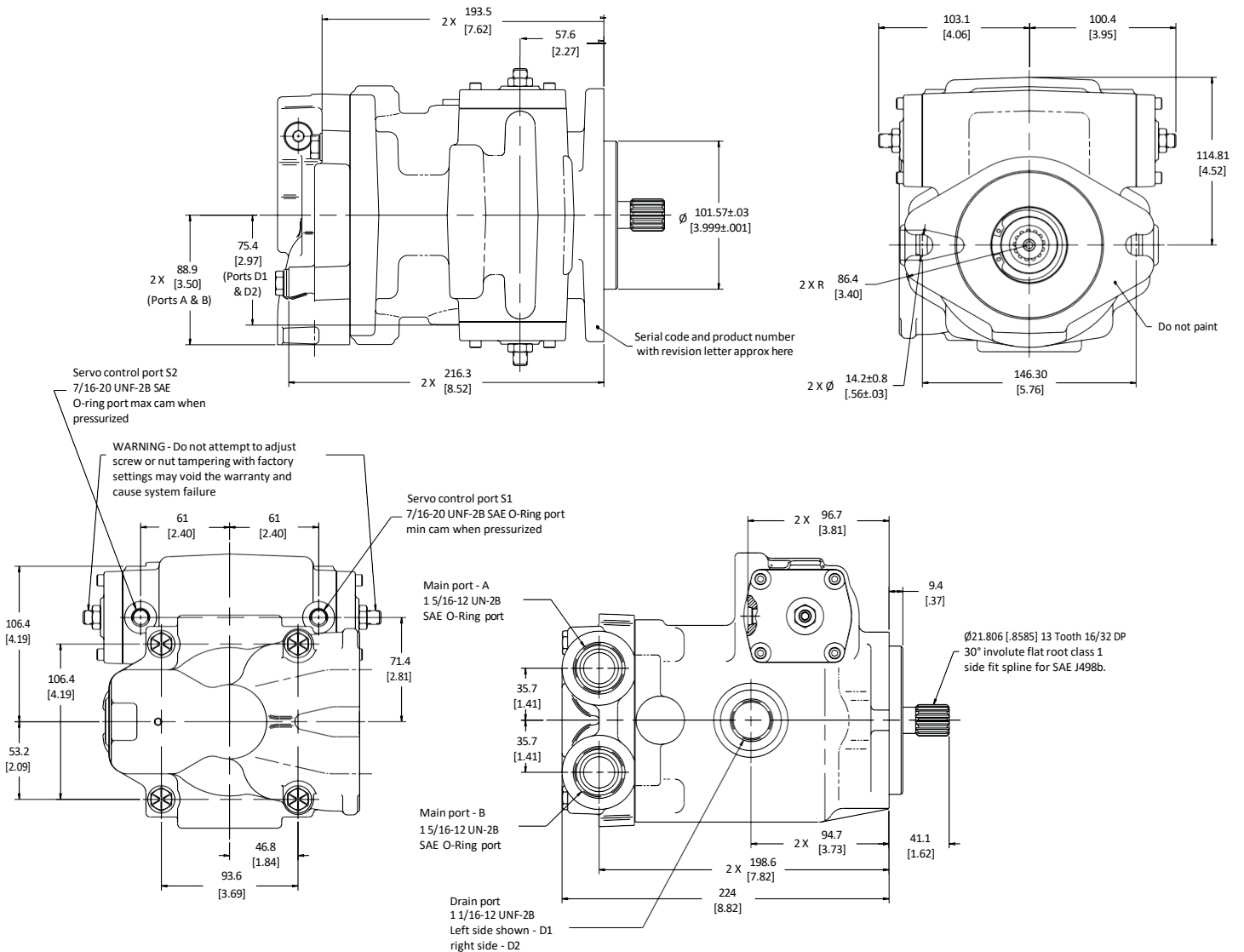

Model 72450 Variable Servo Motor

Shuttle and Charge Pressure Relief Valve

(Code Position 13,14 Selection 03)

Variable motor incorporate integral shuttle valve. The shuttle and charge pressure valve work together to bypass closed loop oil. This allows the oil to be cooled, filtered, and returned to tank. Refer page 19 for further details.

The shuttle valve flow is listed below in relationship to the charge pressure valve setting.

For 72450 series motor:

Charge Pressure	Flow	Code Selection
15.2-17.2 bar [220-250 psi]	9.46 to 13.25 l/m [2.5 to 3.5 gal/min]	03
22.1-23.4 bar [320-340 psi]	14.0 to 17.8 l/m [3.7 to 4.7 gal/min]	05
20.0-21.4 bar [290-310 Psi]	12.5 to 16.27 l/m [3.3 to 4.3 gal/min]	08

Speed Sensor

(Code Position 13,14 Selection 13)

Danfoss has developed a speed sensor, based on the field proven technology of our Hall Effect and Magnetic sensor.

Output – Digital signals from NPN transistors (open collector output with internal 10K pull up resistors).

This sensor has reverse polarity protection, short circuit protection, load dump protection, and EMC (Electrical Magnetic Capability) protection (the customer should qualify the EMC protection in their specific application)

Supply Voltage: 8 to 24 Volt DC (compatible with 12V vehicle conditions)

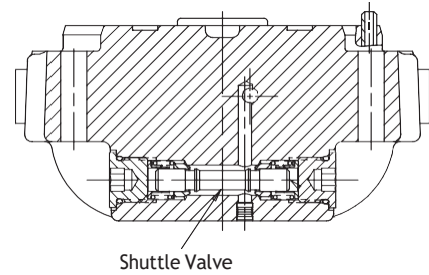
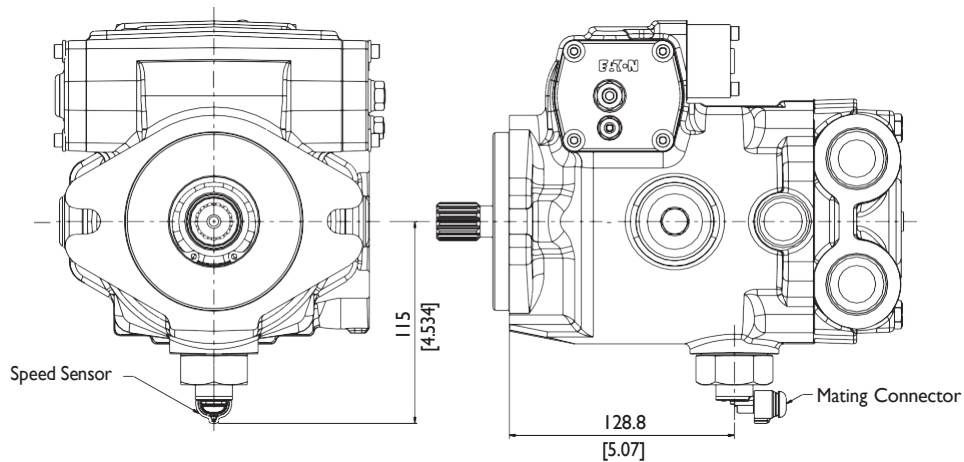

Shuttle Valve

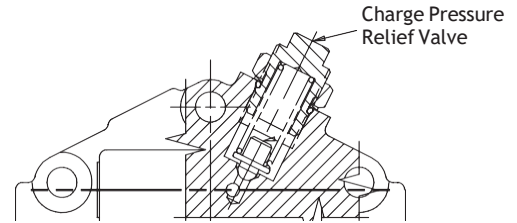

Charge Pressure Relief Valve

Mating Packard Connector

Connector Body – 1216 2192

Connector Seal – 1204 0750

Cable Seal – 1204 0751

Socket – 1212 4075

Optional Mating Connectors

Connector Assembly (Body, Cable Seal, Seal) – 1216 2193

Socket (16 – 18 AWG) – 1212 4075

Socket (20 – 22 AWG) – 1212 4076

Parameter	Condition	Value
Operating Temperature Limit		-40° to 150°C [-40° to 302° F]
Sensor Resistance	25°C (77° F)	1.5 K To 3.5 K Ohms
Sensor Inductance	25°C (77° F)	0.6 to 3.7 H
Output Voltage	25°C (77° F) 9.3 Hz @ 2.29mm [.090 inch] Gap	400 mVpp Min
300 Hz @ 0.25mm [.010 inch] Gap 80 Vpp Max.	300 Hz @ 0.25mm [.010 inch] Gap	80 Vpp Max.
Air Gaps		0.26 to 2.28 mm [.010 to .090 inch]
Vibration Voltage	15G random Vibration	0.4V P-P Max

Note: Dimensions are in millimeters [inches], unless otherwise specified.

Component Selection

The long service life of Danfoss hydrostatic transmissions is largely dependent on the proper selection and installation of the components necessary for transmission operation.

The following components are necessary for transmission operation:

- Variable Displacement Pump
- Fixed or Variable Displacement Motor
- Reservoir
- Filter
- Charge Pump Inlet Line
- Pump and Motor Case Drain Lines
- High Pressure Lines
- Heat Exchanger
- Heat Exchanger Bypass Valve
- Reservoir Return Line

Variable Displacement Pump

Danfoss hydrostatic variable displacement pumps are an axial piston design. They are equipped with standard SAE mounts, shafts and port connections.

Fixed or Variable Displacement Motor

Danfoss hydrostatic motors are an axial piston design. They are equipped with standard SAE mounts, shafts and port connections.

Sizing Equations

For sizing / selecting the right pump for your application please carryout following basic calculations.

Output Flow (Q)

$$\text{lpm} = \frac{\text{cm}^3/\text{r} \times \text{rpm}}{1000} \quad \text{gpm} = \frac{\text{in}^3/\text{r} \times \text{rpm}}{231}$$

Input Power (P)

$$\text{kW} = \frac{\text{l}/\text{min} \times \text{bar}}{600} \quad \text{hp} = \frac{\text{gpm} \times \text{psi}}{1714}$$

Shaft Torque (M)

$$\text{N-m} = \frac{\text{bar} \times \text{cm}^3/\text{r}}{62.8} \quad \text{lb-in} = \frac{\text{psi} \times \text{in}^3/\text{r}}{6.28}$$

Shaft Speed (n)

$$\text{rpm} = \frac{1000 \times \text{l}/\text{min}}{\text{cm}^3/\text{r}} \quad \text{RPM} = \frac{231 \times \text{gpm}}{\text{in}^3/\text{r}}$$

Output Power (P)

$$\text{kW} = \frac{\text{N-m} \times \text{RPM}}{9549} \quad \text{hp} = \frac{\text{lb-in} \times \text{rpm}}{63,025}$$

Volumetric Displacement

$$\text{cm}^3/\text{r} = \frac{\text{lpm} \times 1000}{\text{rpm}} \quad \text{in}^3/\text{r} = \frac{\text{gpm} \times 231}{\text{rpm}}$$

Efficiencies

$$\text{Volumetric } N_v = \frac{\text{gpm actual}}{\text{gpm theoretical}}$$

$$\text{Mechanical } N_m = \frac{\text{lb-in actual}}{\text{lb-in theoretical}}$$

$$\text{Total } N_t = N_v \times N_m$$

Reservoir

The reservoir is an important part of the hydrostatic transmission system. It should provide adequate oil storage and allow easy oil maintenance.

The reservoir must hold enough oil to provide a continuous oil supply to the charge pump inlet. It must also have enough room for the hydraulic oil to expand as the system warms up. Consider charge pump flow when sizing the reservoir: One half (.5) minute times (X) the maximum charge pump flow should be the minimum oil volume in the reservoir. Maintaining this oil volume will give the oil a minimum of thirty (30) seconds in the reservoir. This will allow any entrained air to escape and contamination to settle out of the oil.

To allow for oil expansion, the reservoir's total volume should be at least six tenths (.6) minute times (X) the maximum charge pump flow.

The reservoir's internal structure should cut down turbulence and prevent oil aeration.

The line returning flow to the reservoir should be fitted with a diffuser to slow the incoming oil to 1 to 1.2 meters [3-4 feet] per second to help reduce turbulence. The return flow line should also be positioned so that returning oil enters the reservoir below the liquid surface. This will help reduce aeration and foaming of the oil.

The reservoir should have baffles between the return line and suction line. Baffles prevent return flow from immediately reentering the pump.

A sixty mesh screen placed across the suction chamber of the reservoir will act as a bubble separator. The screen should be placed at a 30° angle to the horizon.

The entrance to the suction line should be located well below the fluid surface so there is no chance of air being drawn into the charge pump inlet. However, the suction line entrance should not be located on the bottom of the reservoir where there may be a buildup of sediment. The suction line entrance should be flared and covered with a screen.

The reservoir should be easily accessible. The fill port should be designed to minimize the possibility of contamination during filling and to help prevent over filling. There should be a drain plug at the lowest point of the reservoir and it should also have a clean-out and inspection cover so the reservoir

Component Selection

can be thoroughly cleaned after prolonged use. A vented reservoir should have a breather cap with a micronic filter.

Sealed reservoirs must be used at altitudes above 2500 feet.

These reservoirs should be fitted with a two-way micronic filter pressure cap to allow for fluid expansion and contraction.

In both cases the caps must be designed to prevent water from entering the reservoir during bad weather or machine washing.

A hydrostatic transmission with a well designed reservoir will run quieter, stay cleaner and last longer.

Filter

A filter must be used to keep the hydraulic fluid clean. Either a suction filter or a pressure side filter may be used. The filter must be a no-bypass type. System oil particle levels should not exceed ISO 18/15 per ISO 4406.

Recommended filters

Pressure line – 5 micrometer

Suction line = 3 OR 5 micrometer

When a suction filter is used, its flow capacity must be large enough to prevent an excessive pressure drop between the reservoir and charge pump inlet. The pressure at the charge pump inlet port must not be less than 0,80 bar absolute [6 in. Hg.] at normal continuous operating temperatures

Charge Pump Inlet Line

The inlet line to the charge pump should be large enough to keep the pressure drop between the reservoir and charge pump inlet within the limits described in the filter section. Fittings will increase the pressure drop, so their number should be kept to a minimum. It is best to keep fluid velocities below 1,25 meters [4 feet] per second.

Fluid and temperature compatibility must be considered when selecting the inlet line.

Pump and Motor Case Drain

The case drain lines should be large enough to limit the pump and motor case pressures (Medium Duty to 2 bar [25 PSI]) at normal operating temperatures. Fluid and temperature compatibility must also be considered when selecting the case drain lines.

High Pressure Lines

The high pressure lines that connect the pump and motor must be able to withstand the pressures generated in the high pressure loop.

Heat Exchanger

Use of a heat exchanger is dependent on the transmission's duty cycle and on machine layout. The normal continuous operating fluid temperature measured in the pump and motor

cases should not exceed 80°C [180°F] for most hydraulic fluids. The maximum fluid temperature should not exceed 107°C [225°F].

The heat exchanger should be sized to dissipate 25% of the maximum input power available to the transmission. It must also be sized to prevent the case pressures in the pump and motor from getting too high. Medium duty case pressure up to 2 bar [25 psi], at normal operating temperatures, are acceptable.

Heat Exchanger Bypass Valve

The heat exchanger bypass valve is a pressure and/or temperature valve in parallel with the heat exchanger. Its purpose is to prevent case pressures from getting too high. The heat exchanger bypass valve opens when the oil is thick, especially during cold starts.

Reservoir Return Line

The same general requirements that apply to case drain lines apply to the reservoir return line.

Bearing Life estimation

Bearing life is defined as the length of time in terms of revolutions or time until a fatigue failure. Bearing load is calculated as a reaction which is derived from the moment created by the piston side load. Magnitude of the side load directly related to the speed and pressure at which a unit can be operated.

Bearing life is a function of the side loads coming on the bearings. Other factors such as fluid type, viscosity of fluid and cleanliness also affects the life of bearing.

If detail bearing life analysis is required, you can contact Danfoss representative.

Installation Requirements

The mounting orientation of pumps and motors is unrestricted provided the case drain of the pump and motor remain full. Position the case drain such that it assures an oil level at or above unit center line at start-up. The case drain line that carries the flow leaving the pump or motor should be connected to the highest drain port on each of the units. This assures that the pump and motor cases remain full.

The combined torque required to turn two or more pumps must not exceed the torque rating of the input drive shaft of the front piston pump. Installer to provide centering and a secure neutral for pump swashplate control shaft. An external support is recommended for all tandems.

Open Loop Circuits

Danfoss pumps and motors may be used in open loop circuits under certain operating conditions. Consult your Danfoss representative for details.

Hydraulic Fluid Recommendations

Introduction

Hydraulic fluids are one of the vital components of hydraulic system. Proper selection of oil assures satisfactory life and operation of system components. The purpose of this section is to provide readers with the knowledge required to select the appropriate fluids for use in systems that employ Danfoss hydraulic components

Viscosity and Temperature

Viscosity is the measure of a fluid's resistance to flow. The most important characteristics to consider when choosing a fluid to be used in a hydraulic system is viscosity. The fluid must be thin enough to flow easily but thick enough to maintain adequate lubricating film between components and to maintain proper sealing at the operating temperatures of the hydraulic system.

For viscosity requirements, see table

Viscosity of any fluid is relative to temperature, as the fluid warms the viscosity decreases and vice versa. When choosing a fluid, it is important to consider the start-up and operating temperatures of the hydraulic system. A high VI fluid shows relatively small change of viscosity with temperature.

Lubricants used for hydraulic applications may contain viscosity index improvers (VII). They refer to these fluids as viscosity index improved or multi-viscosity fluids. The viscosity of these fluids may drop down in use due to shearing of VI improvers used in the formulations.

Anti-wear hydraulic oils containing polymeric thickeners, viscosity index improvers (VII) are generally used for wide band operating temperature applications. These fluids experience temporary and permanent viscosity loss during use in hydraulic system. Check the extent of viscosity loss (shear stability) to avoid hydraulic service below the recommended minimum viscosity. Oil with good shear stability is recommended for wide band temperature applications.

Multi-grade engine oils, ATFs, UTTOs, etc., also contain VIIs, and viscosity loss will be encountered during use.

Cleanliness

Cleanliness of the fluid in a hydraulic system is extremely important. More than 70% of all failures are caused by contamination. Danfoss recommends that the fluid used in its hydraulic components be maintained per ISO 4406. Cleanliness level requirements vary with the hydraulic components. The cleanliness of a hydraulic system is dictated by the cleanliness requirements of the most stringent component in the system.

Cleanliness requirements for specific products are given in the table.

OEM's and distributors who use Danfoss hydraulic components in their hydraulic systems should provide these requirements in their designs.

Contact Danfoss filter representative for filtration information.

Fluid Maintenance

The condition of a fluid has a direct effect on the performance and reliability of the system. Maintaining proper fluid viscosity, cleanliness level, water content, and additive level is essential for excellent hydraulic system performance. Routine fluid condition monitoring is recommended.

Fluid Selection

Premium grade anti-wear (AW) petroleum based hydraulic fluids will provide the best performance with Danfoss hydraulic components. Fluids that meet Danfoss Hydraulic Fluid Specification E-FDGN-TB002-E are considered good quality anti-wear hydraulic fluids. These fluids pass Danfoss Vickers® 35VQ25A high pressure vane pump test (Danfoss ATS-373 test procedure, ASTM D 6973).

Automotive crank case oils with American Petroleum Institute (API) letter designation SF, SG, SH, SJ, or higher per SAE J 183 classes of oils are recommended for applications using Danfoss DG valves. Automotive crankcase oils generally exhibit less shear stability compared to industrial anti-wear hydraulic fluids, which can result in higher loss of viscosity during service life.

Other mineral oil based lubricants commonly used in hydraulic systems are automatic transmission fluids (ATF) and universal tractor transmission oils (UTTO).

Synthetic hydrocarbon base stocks, such as polyalphaolefins (PAO) are also used to formulate hydraulic fluids, engine oils, ATFs and UTTOs. Alternate fluids are recommended when specific properties, such as fire resistance, biodegradability etc., are necessary for the application. Keep in mind that alternative fluids may differ from AW petroleum fluids in properties.

Additional Notes

When choosing a hydraulic fluid, all the components in the system must be considered. Viscosity limitations have to meet the most stringent component requirements.

For any system where the fluid is non-petroleum oil, set the target one ISO code cleaner for each particle size, than that of petroleum fluids.

Keep adequate fluid level in the reservoir. Take fluid level reading when the system is cold.

For more details, refer to Danfoss Fluid Recommendation Document # 03-401-2010.

Contact your Danfoss representative, if you have specific questions about the fluid requirements of Danfoss hydraulic components.

Hydraulic Fluid Recommendations

Viscosity & Cleanliness Recommendation

Product	Minimum *	Optimum	Maximum	ISO Cleanliness
Medium Duty Piston Pumps and Motors Charged Systems	6.0 cSt (45 SUS)	10 – 39 cSt (60-180 SUS)	2158 cSt (10000 SUS)	21/18/13

* Minimum viscosity applies at intermittent condition of 10% of every minute.

At viscosities lower than 70 sus, additional antiwear additives must be added to prevent premature wear.

Additional Notes:

- Fluids too thick to flow in cold weather start-ups will cause pump cavitation and possible damage. Motor cavitation is not a problem during cold start-ups, except for two speed motors. Thick oil can cause high case pressures which in turn cause shaft seal problems.
- When choosing a hydraulic fluid, all the components in the system must be considered and the optimum viscosity range adjusted accordingly. For example, when a medium duty piston pump is combined with a Disk Valve Motor the optimum viscosity range becomes 100 - 180 SUS [20 - 39 cSt] and viscosity should never fall below 70 SUS [13 cSt].
- If the natural color of the fluid has become black it is possible that an overheating problem exists.
- If the fluid becomes milky, water contamination may be a problem.
- Take fluid level reading when the system is cold.
- Contact your Danfoss representative if you have specific questions about the fluid requirements of Danfoss hydraulic components.

Products we offer:

- Cartridge valves
- DCV directional control valves
- Electric converters
- Electric machines
- Electric motors
- Gear motors
- Gear pumps
- Hydraulic integrated circuits (HICs)
- Hydrostatic motors
- Hydrostatic pumps
- Orbital motors
- PLUS+1® controllers
- PLUS+1® displays
- PLUS+1® joysticks and pedals
- PLUS+1® operator interfaces
- PLUS+1® sensors
- PLUS+1® software
- PLUS+1® software services, support and training
- Position controls and sensors
- PVG proportional valves
- Steering components and systems
- Telematics

Danfoss Power Solutions is a global manufacturer and supplier of high-quality hydraulic and electric components. We specialize in providing state-of-the-art technology and solutions that excel in the harsh operating conditions of the mobile off-highway market as well as the marine sector. Building on our extensive applications expertise, we work closely with you to ensure exceptional performance for a broad range of applications. We help you and other customers around the world speed up system development, reduce costs and bring vehicles and vessels to market faster.

Danfoss Power Solutions – your strongest partner in mobile hydraulics and mobile electrification.

Go to www.danfoss.com for further product information.

We offer you expert worldwide support for ensuring the best possible solutions for outstanding performance. And with an extensive network of Global Service Partners, we also provide you with comprehensive global service for all of our components.

Local address:

Hydro-Gear

www.hydro-gear.com

Daikin-Sauer-Danfoss

www.daikin-sauer-danfoss.com

**Danfoss
Power Solutions (US) Company**
2800 East 13th Street
Ames, IA 50010, USA
Phone: +1 515 239 6000

**Danfoss
Power Solutions GmbH & Co. OHG**
Krokamp 35
D-24539 Neumünster, Germany
Phone: +49 4321 871 0

**Danfoss
Power Solutions ApS**
Nordborgvej 81
DK-6430 Nordborg, Denmark
Phone: +45 7488 2222

**Danfoss
Power Solutions Trading
(Shanghai) Co., Ltd.**
Building #22, No. 1000 Jin Hai Rd
Jin Qiao, Pudong New District
Shanghai, China 201206
Phone: +86 21 2080 6201