

Data sheet

Actuators for modulating control

AME 25, AME 35

Description



AME electric actuators are used with, VRB, VRG, VF, VL valves with additional adapter (Code No. **065Z0311**, not supplied) and VFS 2 valves up to DN 50 diameter.

The actuator automatically adapts its stroke to valve end positions which reduces commissioning time.

The actuator has some special features:

- The advanced design incorporates load related 'switch-off' to ensure that actuators and valves are not exposed to overload;
- The advanced design incorporates a diagnostic LED, operational data capture and self stroking feature;
- Low weight and robust;

Main data:

- Nominal voltage:
 - 24 VAC, 50 Hz/60 Hz
- Control input signal:
 - 0(4)...20 mA
 - 0(2) ... 10 V
- Force:
 - AME 25 ... 1000 N
 - AME 35 600 N
- Stroke: 15 mm
- Speed:
 - AME 25... 11 s/mm
 - AME 35.... 3 s/mm
- Max. medium temperature: 150 °C
- Self stroking
- Output signal

Ordering

Actuators

| Type | Supply voltage (Vac) | Code No. |
|--------|----------------------|-----------------|
| AME 25 | 24 | 082G3025 |
| AME 35 | | 082G3022 |

Accessories

| Type | Code No. |
|--|------------------|
| Adapter for VFS 2 valve DN 15-50 (for media temp. over 150 °C) | 065Z7548 |
| Adapter for VRB/VRG/VF/VL valves (gen.2009) DN 15-50 | 065Z0311* |
| Stem heater for VFS valve DN 15-50 | 065B2171 |
| Clutch AMV(E) 25, AMV(E) 35 | 003G6396 |

* Needs to be ordered separately.

Technical data

| Type | | AME 25 | AME 35 |
|--|------|---|---------|
| Power supply | V | 24 ac; +10 to -15% | |
| Power consumption | VA | 4 | 9 |
| Frequency | Hz | 50/60 | |
| Control input Y | V | 0-10 (2-10) Ri = 24 kΩ | |
| | mA | 0-20 (4-20) Ri = 500 Ω | |
| Output signal X | V | 0-10 (2-10) | |
| Closing force | N | 1000 | 600 |
| Max. stroke | mm | 15 | |
| Speed by 50(60) Hz | s/mm | 11 (8.8) | 3 (2.4) |
| Max. medium temperature | °C | 150 (200 - with adapter or mounted horizontally) | |
| Ambient temperature | | 0 ... 55 | |
| Storage and transport temp. | | -40 ... 70 | |
| Grade of enclosure | | IP 54 | |
| Weight | kg | 1.70 | |
| - marking in accordance with standards | | Low Voltage Directive 73/23/EEC, EMC-Directive 2006/95/EEC: - EN 60730-1, EN 60730-2-14 | |

Installation

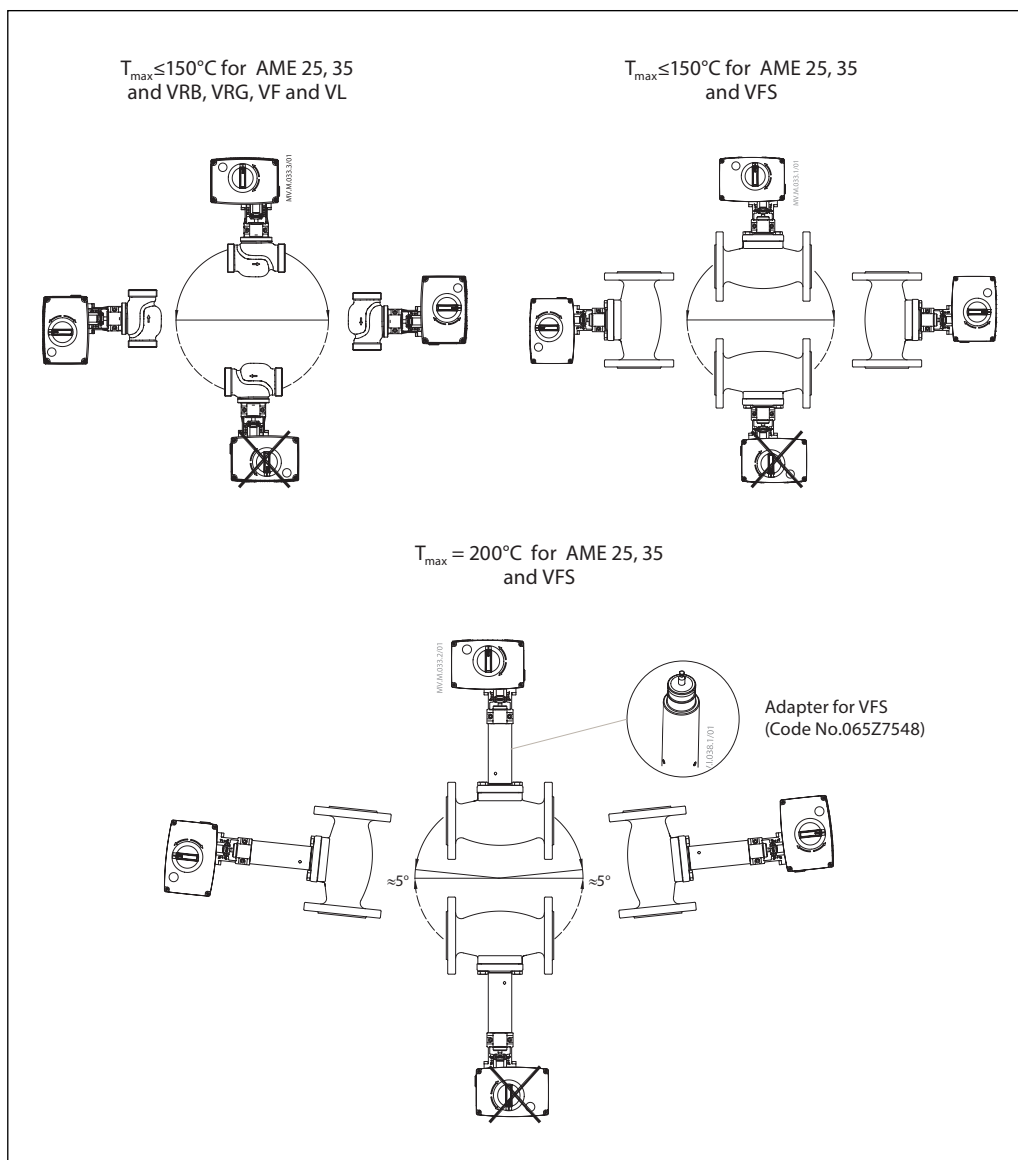

Mechanical

Use 4 mm Allan key (not part of actuator delivery) to mount actuator on the valve. Installation of the valve with the actuator is allowed in horizontal position or upwards. Installation downwards is not allowed.

The actuator must not be installed in an explosive atmosphere, at ambient temperature lower than 0 °C or at ambient temperature higher than 55 °C. It must not be subject to steam jets, water jets or dripping liquid as well.

Note: the actuator may be rotated up to 360° with respect to the valve stem by loosening the retaining fixture. Once the actuator is placed, retighten the fixture.

Electrical

Electrical connections can be accessed by removing the actuator cover. Two cable gland entries with thread (M20 x 1.5 and M16 x 1.5) are prepared for cable glands.

Note: Cable and cable gland used must not compromise the actuator's IP rating, and must ensure the connectors are fully strain relieved. Please observe local rules and regulations as well.

DIP switch setting

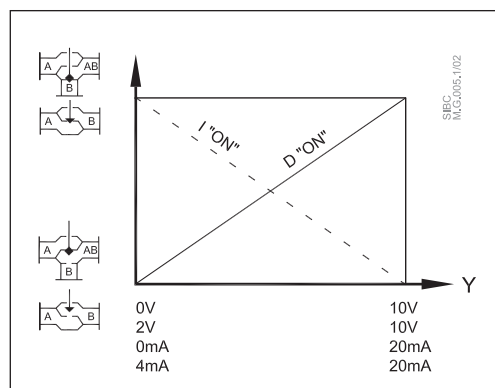
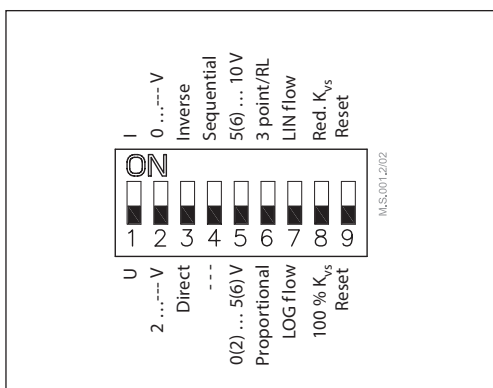

The actuator has a function selection DIP switch under the removable cover. In particular, if SW6 is set to ON, the actuator will perform as 3-point actuator.

The switch provides the following functions:

- **SW1: U/I - Input signal type selector:**
If set to OFF position, voltage input is selected. If set to ON position, current input is selected.
- **SW2: 0/2 - Input signal range selector:**
If set to OFF position, the input signal is in the range from 2-10 V (voltage input) or from 4-20 mA (current input). If set to ON position, the input signal is in the range from 0-10 V (voltage input) or from 0-20 mA (current input).
- **SW3: D/I - Direct or inverse acting selector:**
If set to OFF position, the actuator is direct acting (stem lowers as voltage increases). If actuator is set to ON position the actuator is inverse acting (stem raises as voltage increases).
- **SW4: —/Seq - Normal or sequential mode selector:**
If set to OFF position, the actuator is working in range 0(2)-10 V or 0(4)-20 mA. If set to ON position, the actuator is working in sequential range: 0(2)-5(6) V or 0(4)-10(12) mA or 5(6)-10 V or 10(12)-20 mA).
- **SW5: 0-5 V/5-10 V - Input signal range in sequential mode:**
If set to OFF position, the actuator is working in sequential range 0(2)-5(6) V or 0(4)-10(12) mA. If set to ON position, the actuator is working in sequential range; 5(6)-10 V or 10(12)-20 mA.

• **SW6: Prop./3-pnt - Modulating or 3-point mode selector:**

If set to OFF position, the actuator is working normally according to control signal. If set to ON position, the actuator is working as 3-point actuator.

For this operation please refer to page 4 (wiring 3-point control).

When DIP switch SW6 is set to ON than all functions from other DIP switch become inactive.

• **SW7: LOG/LIN - Equal percentage or linear flow through valve selector ¹⁾:**

If set to OFF position, the flow through valve is equal percentage. If set to ON position, the flow through valve is linear according to control signal.

• **SW8: 100% K_{vs}/Reduced K_{vs} - Flow reduction through valve selector ¹⁾:**

If set to OFF position, the flow through valve is not reduced. If set to ON position, the flow through valve is reduced by half of increment between standard K_{vs} values. Example: valve with K_{vs} 16 and SW8 set to ON – maximum flow through the valve is K_{vs} 13 (middle between standard K_{vs} 16 and next lower standard K_{vs} 10).

¹⁾ **NOTE:** To be used only in combination with valves with equal percentage characteristic.

• **SW9: Reset:**

Changing this switch position will cause the actuator to go through a self stroking cycle.

Wiring



24 Vac

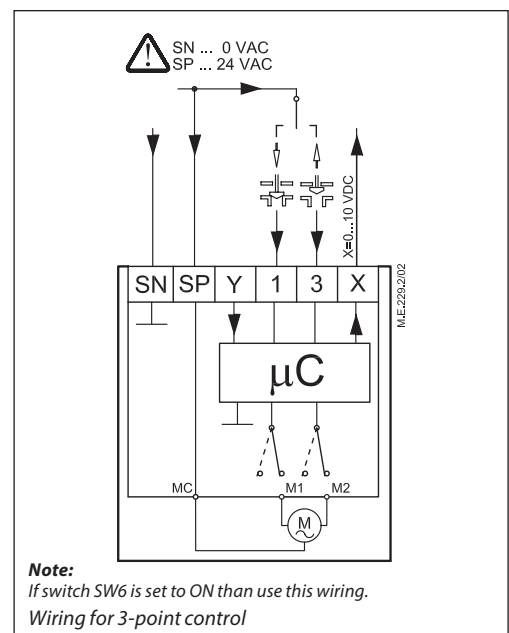
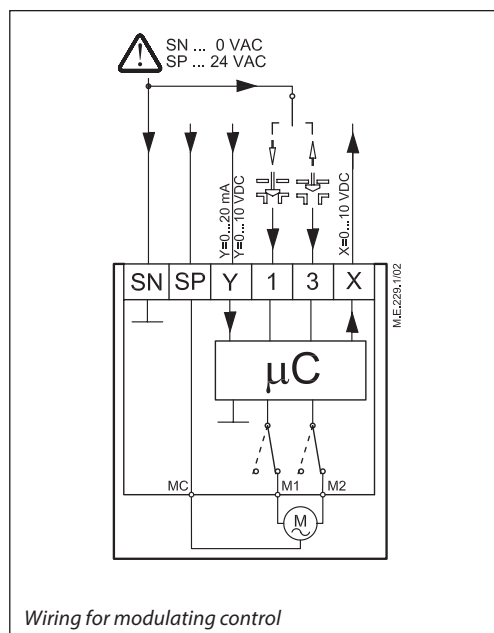

Automatic self stroking feature

When power is first applied, the actuator will automatically adjust to the length of the valve stroke. Subsequently, the self stroking feature can be re-initialised by changing position of SW9.

Diagnostic LED

The red diagnostic LED is located on the pcb under the cover. It provides indication of three operational states:

- Actuator Healthy (Permanently ON),
- Self Stroking (Flashes once per second),
- Error (Flashes 3 times per second - seek technical assistance).

| Wiring length | Recommended square of the wiring |
|---------------|----------------------------------|
| 0-50 m | 0.75 mm ² |
| > 50 m | 1.5 mm ² |

| | | |
|-----------|---------------|---------------|
| SP | 24 V ac | Power supply |
| SN | 0 V | Common |
| Y | 0-10 V | Input signal |
| | (2-10 V) | |
| | 0-20 mA | |
| | (4-20 mA) | |
| X | 0-10 V | Output signal |
| | (2-10 V) | |

Commissioning

Complete the mechanical and electrical installation and perform the necessary checks and tests:

- Isolate control medium. (E.g. self stroking in a steam application without suitable mechanical isolation could cause a hazard).
- Apply the power.
Note that the actuator will now perform the self stroking function.
- Apply the appropriate control signal and check the valve stem direction is correct for the application.
- Ensure that the actuator drives the valve over its full stroke, by applying the appropriate control signal. This action will set the valve stroke length.

The unit is now fully commissioned.

Commissioning / testing feature

The actuator can be driven to the fully open or closed positions (depending on valve type) by connecting SN to terminals 1 or 3.

Manual override

The manual override is achieved by turning the manual knob to the required position. Observe the direction of rotation symbol. If manual override has been used then X and Y signal are not correct until the actuator reaches its end position. If this is not accepted, mount accessory active return signal kit.

Procedure

- Press rubber button
- Adjust valve position using control knob
- Set valve to closed position
- Restore power supply

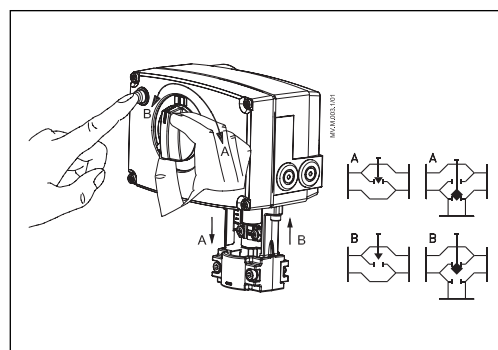

Actuator - valve combinations

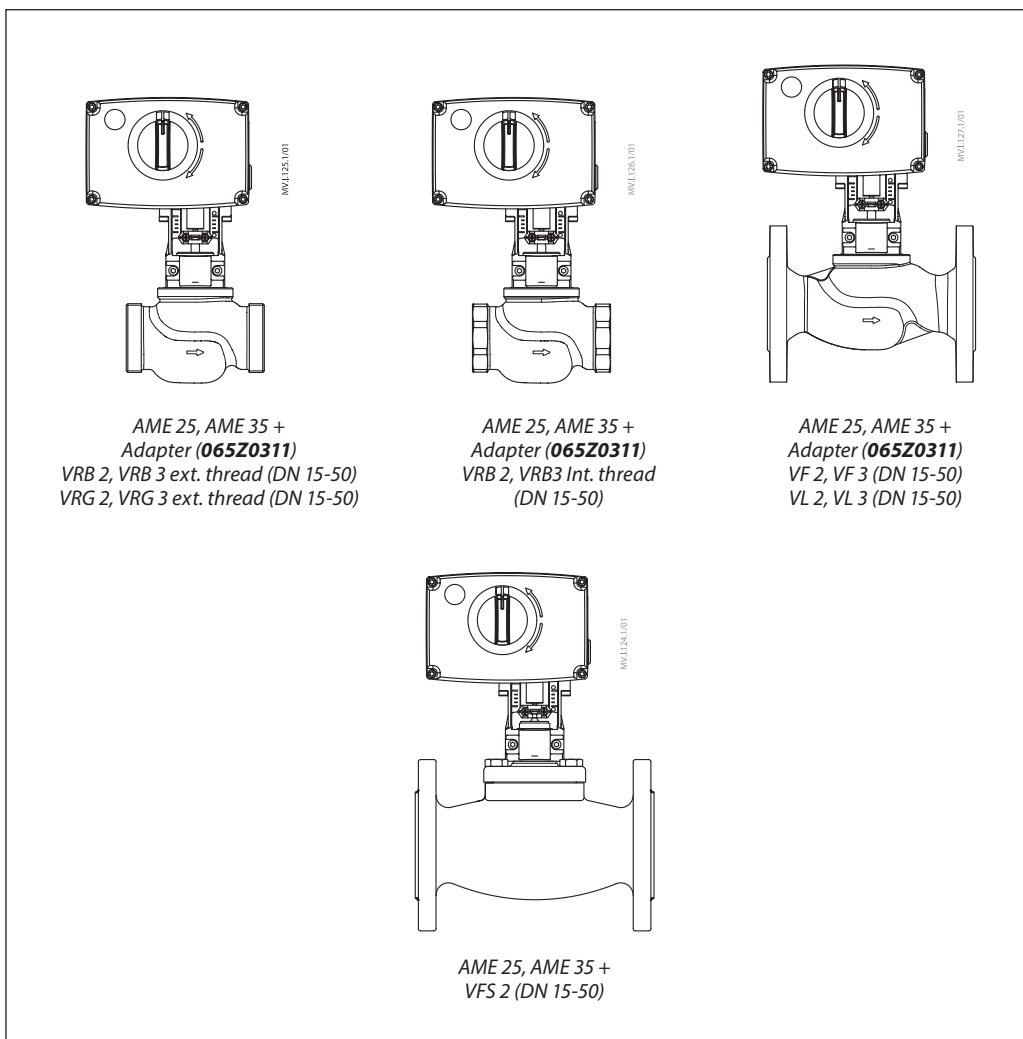

Dimensions

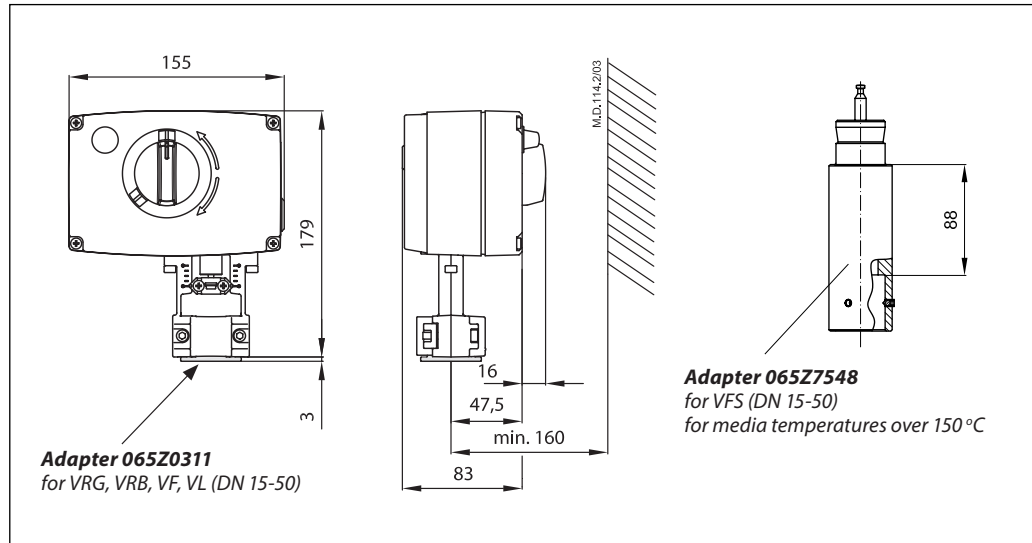

Danfoss A/S

Climate Solutions • danfoss.com • +45 7488 2222

Any information, including, but not limited to information on selection of product, its application or use, product design, weight, dimensions, capacity or any other technical data in product manuals, catalogues descriptions, advertisements, etc. and whether made available in writing, orally, electronically, online or via download, shall be considered informative, and is only binding if and to the extent, explicit reference is made in a quotation or order confirmation. Danfoss cannot accept any responsibility for possible errors in catalogues, brochures, videos and other material. Danfoss reserves the right to alter its products without notice. This also applies to products ordered but not delivered provided that such alterations can be made without changes to form, fit or function of the product.

All trademarks in this material are property of Danfoss A/S or Danfoss group companies. Danfoss and the Danfoss logo are trademarks of Danfoss A/S. All rights reserved.