

Data Sheet

# Shut-off valve Type **SVA-S** and **SVA-L**

Assures favorable flow characteristics in industrial refrigeration applications



SVA shut-off valves are available in angleway and straightway versions and with Standard neck (SVA-S) and Long neck (SVA-L)

The shut-off valves are designed to meet all industrial refrigeration application requirements and are designed to give favourable flow characteristics and are easy to dismantle and repair when necessary.

The valve cone is designed to ensure perfect closing and withstand a high system pulsation and vibration, which can be present specifically in the discharge line.

### Features

- Applicable to HCFC, HFC, R717 (Ammonia), R744 (CO<sub>2</sub>) and all flammable refrigerants.
- Modular Concept:
  - Each valve housing is available with several different connection types and sizes
  - Possible to convert SVA-S or SVA-L to any other product in the Flexline™ SVL family (hand operated regulating valve, check & stop valve, check valve or strainer) just by replacing the complete top part
- Fast and easy valve overhaul service. It is easy to replace the top part and no welding is needed
- Optional accessories:
  - Heavy duty industrial hand wheel for frequent operation
  - Cap for infrequent operation
- Available in angleway and straightway versions with Standard neck or Long neck (DN 15 to DN 40) for insulated systems
- Each valve type is clearly marked with type, size and performance range
- The valves and caps are prepared for sealing, to prevent operation by unauthorized persons, using a seal wire
- Internal metal backseating: – DN 6 - 65 (¼ - 2½ in.)
- Internal PTFE backseating: – DN 80 - 200 (3 - 8 in.)
- Can accept flow in both directions
- Housing and bonnet material is low temperature steel according to requirements of the Pressure Equipment Directive and other international classification authorities
- Equipped with stainless steel bolts
- Max. working pressure: 52 bar / 754 psig
- Temperature range: -60/+150 °C (-76/+302 °F)
- Classification: DNV, CRN, BV, EAC etc. To get an updated list of certification on the products please contact your local Danfoss Sales Company.

## Media

### **Refrigerants**

Applicable to HCFC, HFC, R717 (Ammonia), R744 (CO<sub>2</sub>) and all flammable refrigerants.

### **New refrigerants**

Danfoss products are continually evaluated for use with new refrigerants depending on market requirements.

When a refrigerant is approved for use by Danfoss, it is added to the relevant portfolio, and the R number of the refrigerant (e.g. R513A) will be added to the technical data of the code number. Therefore, products for specific refrigerants are best checked at [store.danfoss.com/en/](https://store.danfoss.com/en/), or by contacting your local Danfoss representative.

## Product specification

### Design

#### Housing

Made of special, cold resistant steel.

#### Valve cone

The valve cone can be turned on the spindle, thus there will be no friction between the cone and the seat when the valve is opened and closed and the special design will avoid cone spin due to pulsation and vibration when the valve is in open position. A teflon tightening ring provides perfect sealing with minimum closing force.

#### Spindle

Made of polished stainless steel, ideal for leap seal sealing.

#### Packing gland

The low temperature packing gland ensures a perfect tightness in the range:  $-60/+150\text{ }^{\circ}\text{C}$  ( $-76/+302\text{ }^{\circ}\text{F}$ ). The packing glands are equipped with a scraper ring to prevent penetration of dirt and ice into the packing gland.

#### Installation

It is recommended that the valves be installed in the direction of flow indicated by the arrow on the valve body. The valve can be installed in the opposite direction but this slightly reduces the  $k_v$ -value ( $C_v$ -value).

The valve is designed to withstand high internal pressure. However, the piping system in general should be designed to avoid liquid traps and reduce the risk of hydraulic pressure caused by thermal expansion.

For further information refer to installation instructions for SVA.

Figure 1: Example of Marking Ring

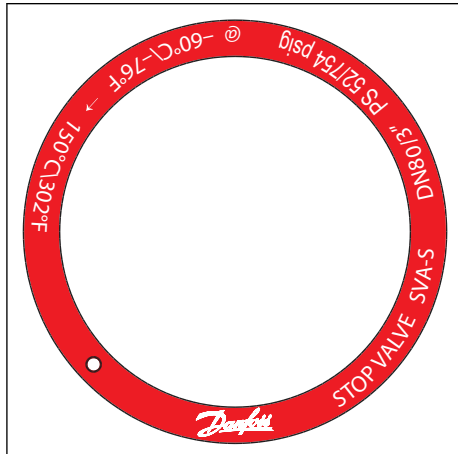

## Pressure and temperature data

Table 1: Pressure and temperature

Description	Values
Temperature range	-60/+150 °C (-76/+302 °F)
Max. working pressure	52 bar / 754 psig

### Maximum opening and closing pressure differential (for sizes 100 to 200)

Figure 2: Flow direction

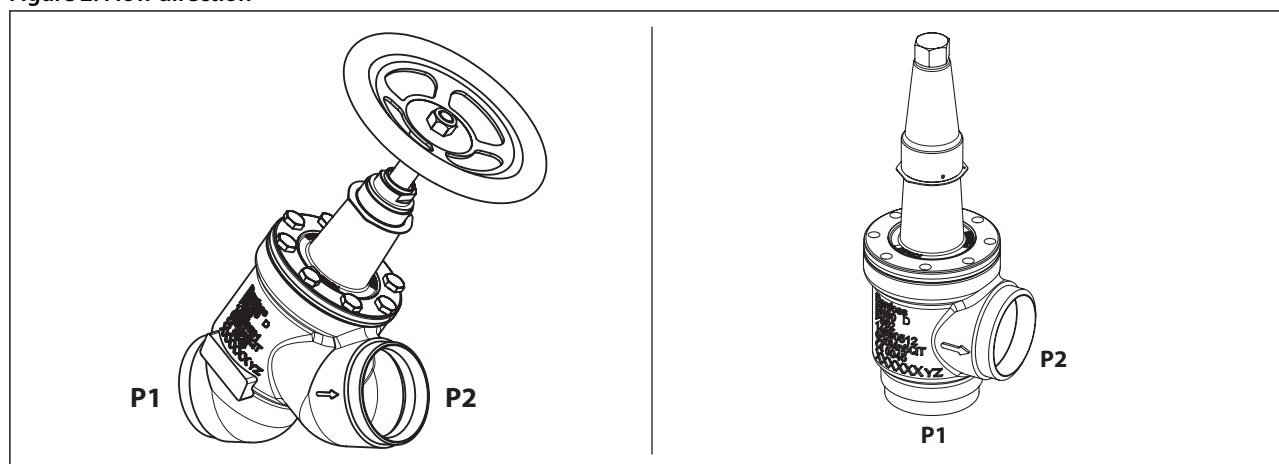

The maximum opening pressure differential is equal to the maximum pressure difference between inlet and outlet in the flow direction where the valve can be opened using normal hand force without damaging the valve.

The maximum closing pressure differential is equal to the maximum pressure difference between inlet and outlet in the flow direction where the valve is sealing according to specifications.

The maximum opening and closing pressure differentials are as default equal to the maximum operating pressure (PS or MWP) for valve sizes up to and including DN 80.

For valve sizes of DN 100 or larger than DN 100 the opening and closing pressure differential depends on the flow direction as shown below. Note that the default flow direction indicated by the flow arrow is P1 -> P2.

Table 2: Flow direction

Valve size [DN]	Flow direction		
	P1 → P2	P2 → P1	P2 → P1
	Maximum opening and closing pressure differential	Maximum closing pressure differential	Maximum opening pressure differential
100	44 bar / 638 psi	52 bar / 754 psi	44 bar / 638 psi
125	33 bar / 478 psi	52 bar / 754 psi	33 bar / 478 psi
150	21 bar / 304 psi	52 bar / 754 psi	21 bar / 304 psi
200	14 bar / 203 psi	52 bar / 754 psi	14 bar / 203 psi

## Connections

Available with the following connections:

- Butt-weld DIN (EN 10220)
- Butt-weld ANSI (B 36.10 Schedule 80), DN 6 - 40 (¼ - 1½ in.)
- Butt-weld ANSI (B 36.10 Schedule 40), DN 50 - 200 (2 - 8 in.)
- Butt-weld GOST, (8734-75 and 8732-78) DN 10 - 150 (¾ - 6 in.)
- Socket Weld (ANSI B 16.11), DN 15 - DN 50 (½ - 2 in.)
- Outside pipe thread G ½ in. - G 7/8 in. (ISO 228/1)
- FPT Female Pipe Thread, NPT (ANSI/ASME B 1.20.1), DN 15 - 32 (½ - 1¼ in.)
- Special combination (DN 20 only), Socket weld inlet, FPT ¾ in. outlet
- Special connections Butt-weld F, see (link to [AI174086419766\\_SVL](#))

## Shut-off valve, type SVA-S and SVA-L

Figure 3: DIN

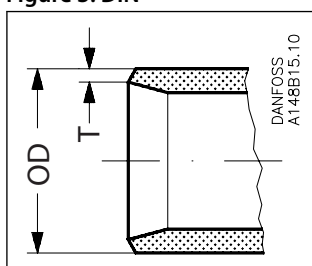

Table 3: Butt-weld DIN (EN 10220)

Size mm	Size in.	OD mm	T mm	OD in.	T in.	$k_v$ -angle m <sup>3</sup> /h	$k_v$ -straight m <sup>3</sup> /h	$C_v$ -angle USgal/min	$C_v$ -straight USgal/min
6	¼	13.5	2.3	0.531	0.091	2.9	2.0	3.4	2.4
10	⅜	17.2	2.3	0.677	0.091	4.5	3.2	5.2	3.6
15	½	21.3	2.3	0.839	0.091	7.0	4.9	8.1	5.7
20	¾	26.9	2.3	1.059	0.091	14.6	10.2	16.9	11.8
25	1	33.7	2.6	1.327	0.103	24.8	17.4	28.8	20.2
32	1¼	42.4	2.6	1.669	0.102	42.6	29.8	49.4	34.6
40	1½	48.3	2.6	1.902	0.103	45.2	31.6	52.4	36.7
50	2	60.3	2.9	2.37	0.11	80	65	93	76
65	2½	76.1	2.9	3	0.11	120	97	140	113
80	3	88.9	3.2	3.50	0.13	182	152	211	176
100	4	114.3	3.6	4.50	0.14	313	278	363	323
125	5	139.7	4.0	5.50	0.16	514	470	596	545
150	6	168.3	4.5	6.63	0.18	785	597	911	693
200	8	219.1	6.3	8.63	0.25	1168	1024	1355	1188

Figure 4: ANSI

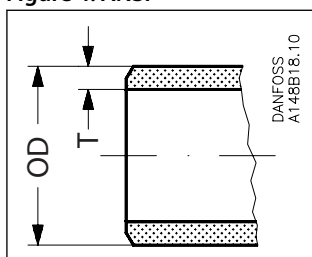

Table 4: Butt-weld ANSI (B 36.10 Schedule 80)

Size mm	Size in.	OD mm	T mm	OD in.	T in.	$k_v$ -angle m <sup>3</sup> /h	$k_v$ -straight m <sup>3</sup> /h	$C_v$ -angle USgal/min	$C_v$ -straight USgal/min
6	¼	13.5	3.0	0.531	0.118	2.9	2.03	3.4	2.4
10	⅜	17.2	3.2	0.677	0.126	4.5	3.15	5.2	3.6
15	½	21.3	3.7	0.839	0.146	7.0	4.9	8.1	5.7
20	¾	26.9	4.0	1.059	0.158	14.6	10.2	16.9	11.8
25	1	33.7	4.6	1.327	0.181	24.8	17.4	28.8	20.2
32	1¼	42.4	4.9	1.669	0.193	42.6	29.8	49.4	34.6
40	1½	48.3	5.1	1.902	0.201	45.2	31.6	52.4	36.7

Table 5: Butt-weld ANSI (B 36.10 Schedule 40)

Size mm	Size in.	OD mm	T mm	OD in.	T in.	$k_v$ -angle m <sup>3</sup> /h	$k_v$ -straight m <sup>3</sup> /h	$C_v$ -angle USgal/min	$C_v$ -straight USgal/min
50	2	60.3	3.9	2.37	0.15	80	65	93	76
65	2½	73.0	5.2	2.87	0.20	120	97	140	113
80	3	88.9	5.5	3.50	0.22	182	152	211	176
100	4	114.3	6.0	4.50	0.24	313	278	363	323
125	5	141.3	6.6	5.56	0.26	514	470	596	545
150	6	168.3	7.1	6.63	0.28	785	597	911	693
200	8	219.1	8.2	8.63	0.32	1168	1024	1355	1188

## Shut-off valve, type SVA-S and SVA-L

Figure 5: GOST

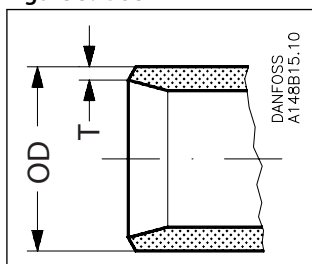

Table 6: Butt-weld GOST (8734-75 and 8732-78)

Size mm	Size in.	OD mm	T mm	OD in.	T in.	$k_v$ -angle m <sup>3</sup> /h	$k_v$ -straight m <sup>3</sup> /h	$C_v$ -angle USgal/min	$C_v$ -straight USgal/min
10	3/8	14	2	0.551	0.079	4.5	3.2	5.2	3.6
15	1/2	18	2	0.709	0.079	7	4.9	8.1	5.7
20	3/4	25	2.5	0.984	0.098	14.6	10.2	16.9	11.8
25	1	32	3	1.260	0.118	24.8	17.4	28.8	20.2
32	1 1/4	38	3	1.496	0.118	42.6	29.8	49.4	34.6
40	1 1/2	45	3	1.772	0.118	45.2	31.6	52.4	36.7
50	2	57	3.5	2.244	0.138	80	65	93	76
65	2 1/2	76.1	2.9	3	0.11	120	97	140	113
80	3	88.9	3.2	3.50	0.13	182	152	211	176
100	4	108	4	4.252	0.157	313	278	363	323
125	5	133	4	5.236	0.157	514	470	596	545
150	6	159	4.5	6.260	0.177	785	597	911	693

Figure 6: SOC

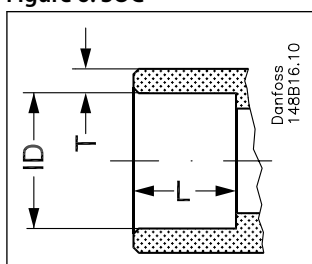
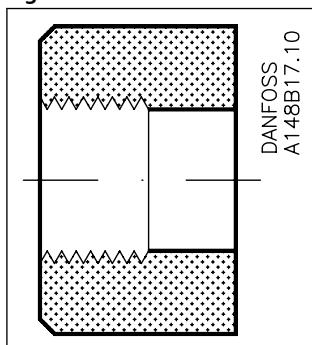

Table 7: Socket welding ANSI (B 16.11)

Size mm	Size in.	OD mm	T mm	OD in.	T in.	L mm	L in.	$k_v$ -angle m <sup>3</sup> /h	$k_v$ -straight m <sup>3</sup> /h	$C_v$ -angle USgal/min	$C_v$ -straight USgal/min
15	1/2	21.8	6.0	0.858	0.235	10	0.39	7.0	4.9	8.1	5.7
20	3/4	27.2	4.6	1.071	0.181	13	0.51	14.6	10.9	16.9	11.8
25	1	33.9	7.2	1.335	0.284	13	0.51	24.8	17.4	28.8	20.2
32	1 1/4	42.7	6.1	1.743	0.240	13	0.51	42.6	29.8	49.4	34.6
40	1 1/2	48.8	6.6	1.921	0.260	13	0.51	45.2	31.6	52.4	36.7
50	2	61.2	6.2	2.41	0.24	16	0.63	80	65	93	76

Figure 7: FPT



## Shut-off valve, type SVA-S and SVA-L

**Table 8: FPT inside pipe thread, NPT (ANSI/ASME B 1.20.1)**

Size mm	Size in.	Inside pipe thread	$k_v$ -angle m <sup>3</sup> /h	$k_v$ -straight m <sup>3</sup> /h	$C_v$ -angle USgal/min	$C_v$ -straight USgal/min
15	½	(½ × 14 NPT)	8.5	6.0	9.9	7.0
20	¾	(¾ × 14 NPT)	10	7.0	11.6	8.1
25	1	(1 × 11.5 NPT)	32	22.4	37.1	26.0
32	1¼	(1¼ × 11.5 NPT)	36	25.2	41.8	29.3

## Connections - SVA 6

**Figure 8: T**

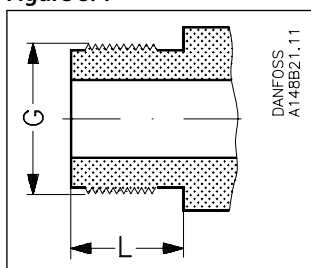

**Table 9: T outside pipe thread, (ISO 228/1)**

Size mm	Size in.	Outside pipe thread	L mm	L in.	$k_v$ -angle m <sup>3</sup> /h	$k_v$ -straight m <sup>3</sup> /h	$C_v$ -angle USgal/min	$C_v$ -straight USgal/min
6	¼	G 1/2	16	0.63	2.5	2.0	2.9	2.0

**Figure 9: ND**

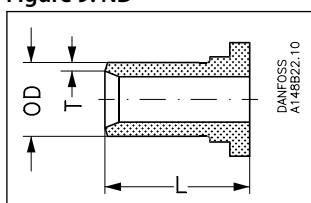

**Table 10: Nipples for T outside pipe thread, (ISO 228/1)**

Size mm	Size in.	OD mm	T mm	OD in.	T in.	L mm	L in.	Inside pipe thread
6	¼	13.5	2.3	0.531	0.091	60	2.36	G½

**Figure 10: NA**

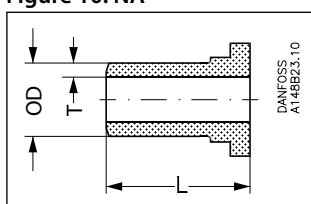

**Table 11: NA welding nipples, ANSI (B 36.10 Schedule 80)**

Size mm	Size in.	OD mm	T mm	OD in.	T in.	L mm	L in.	Inside pipe thread
6	¼	13.5	3.0	0.531	0.118	60	2.36	G½



## Material specification

Figure 11: SVA-S 6-10 and SVA-S 15-20

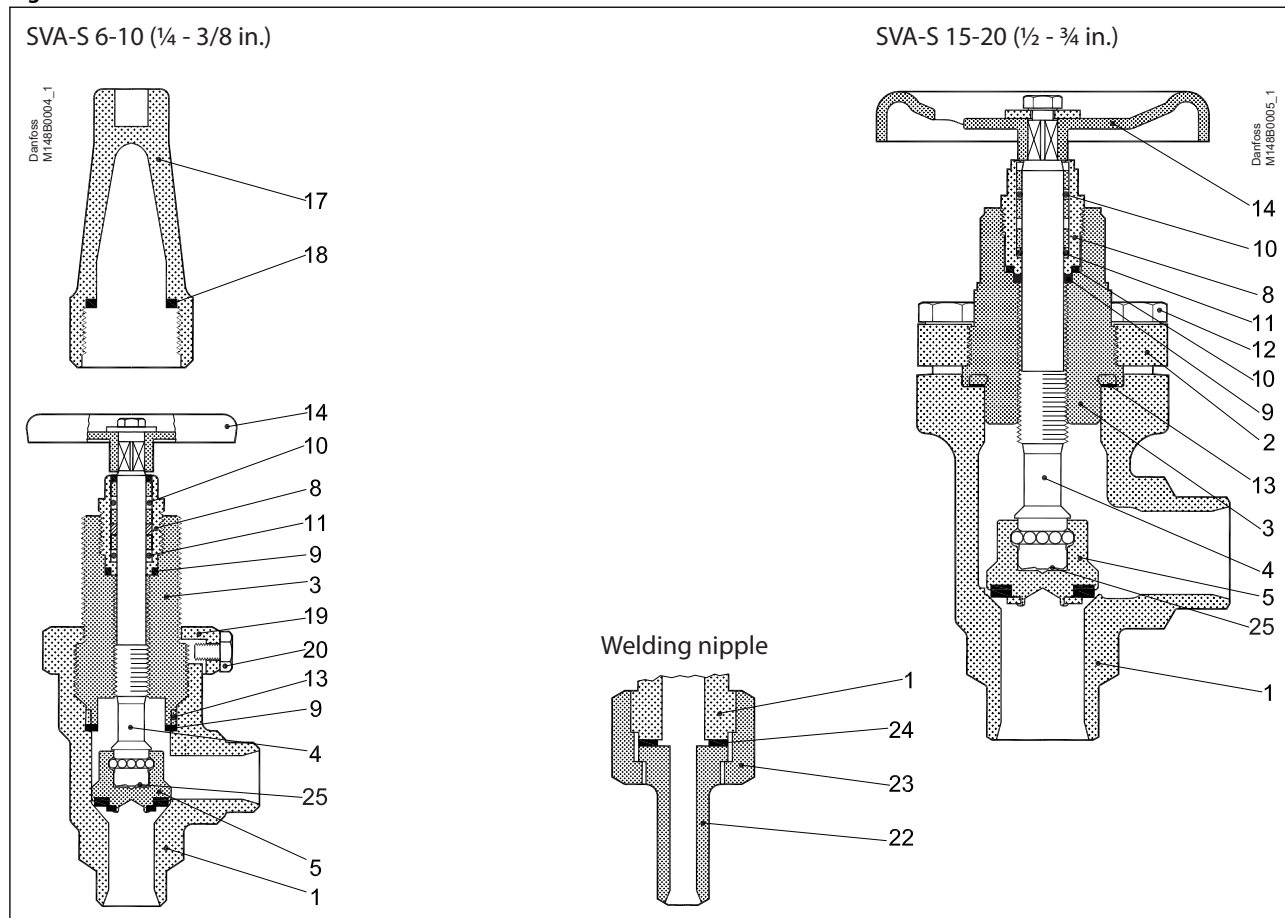

Table 12: Material and parts list

No.	Part	Material	EN	ISO	ASTM
1	Housing	Steel	G20Mn5QT, 10213-3 P285QH+QT, 10222-4		LCC, A352 LF2, A350
2	Bonnet, Flange	Steel	G20Mn5QT, 10213-3 P285QH+QT, 10222-4 P275NL, 10028-3		LCC, A352 LF2, A350
3	Bonnet, Insert	Steel	11SMn30 10087	Type 2 R 683/9	AISI 1213
4	Spindle	Stainless steel	X8CrNiS18-9 10088	Type 17 683/13	AISI 303
5	Cone	Steel	11SMn30 10087	Type 2 R 683/9	AISI 1213
8	Packing gland	Stainless steel	X8CrNiS18-9 10088	Type 17 683/13	AISI 303
9	Packing washer	Aluminium			
10	O-ring	Chloroprene (Neoprene)			
11	Spring loaded Teflon ring	PTFE			
12	Bolts	Stainless steel	A2-70	A2-70	Type 308
13	Gasket	Fiber, Non-asbestos			
14	Handwheel	Steel			
17	Cap	Aluminium			
18	Gasket for cap	Nylon			
19	Locking nut	Steel			
20	Screw	Steel			
22	Welding nipple	Steel	S235JRG2 10025	Fe260B, 630	Grade C, A 283

## Shut-off valve, type SVA-S and SVA-L

No.	Part	Material	EN	ISO	ASTM
23	Nut	Steel	11SMn30 10087	Type 2 R 683/9	AISI 1213
24	Packing washer	Non-asbestos			
25	Disk spring	Steel			

Figure 12: SVA-S 25-40 (1 - 1½ in.)

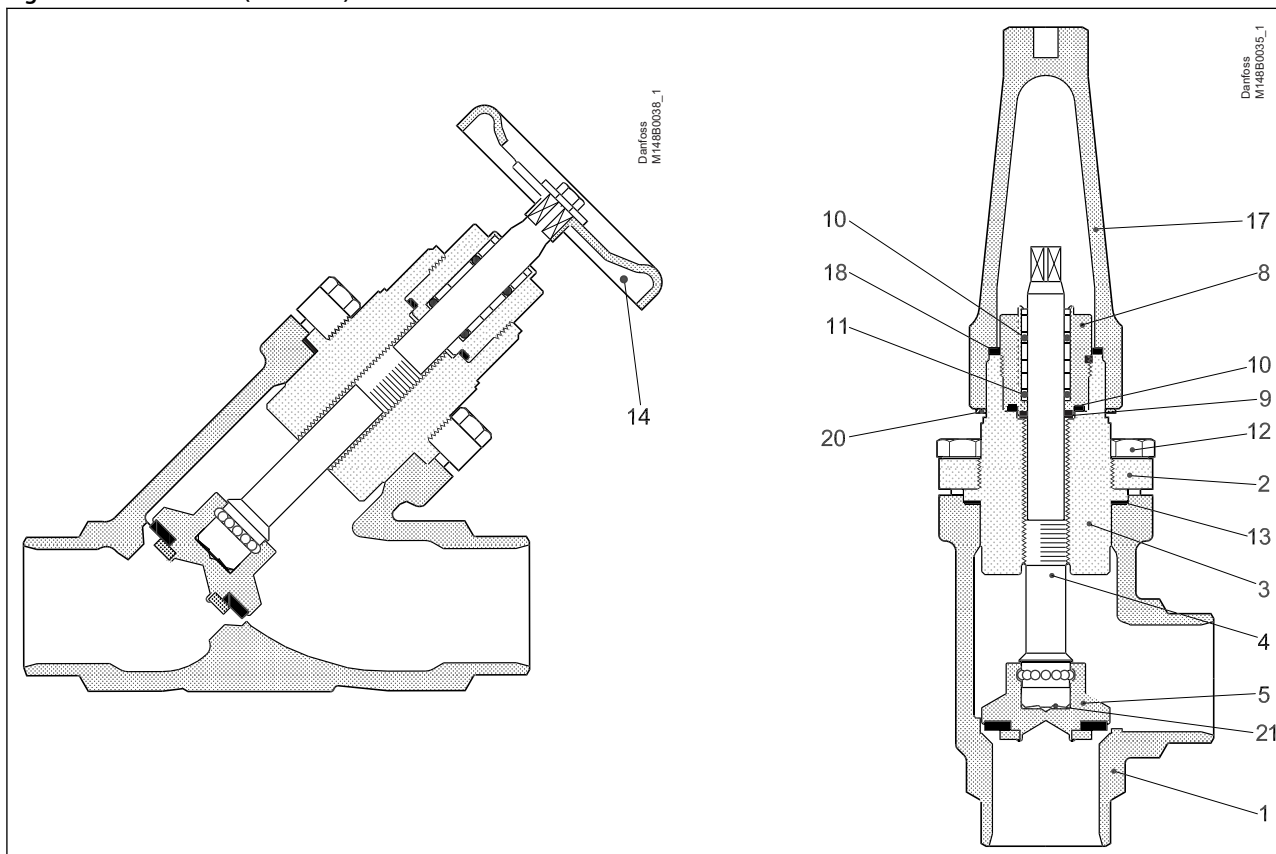

Table 13: Material and parts list

No.	Part	Material	EN	ISO	ASTM
1	Housing	Steel	G20Mn5QT, 10213-3 P285QH+QT, 10222-4		LCC, A352 LF2, A350
2	Bonnet, Flange	Steel	G20Mn5QT, 10213-3 P285QH+QT, 10222-4 P275NL, 10028-3		LCC, A352 LF2, A350
3	Bonnet, Insert	Steel	11SMn30 10087	Type 2 R 683/9	AISI 1213
4	Spindle	Stainless steel	X8CrNiS18-9 10088	Type 17 683/13	AISI 303
5	Cone	Steel	11SMn30 10087	Type 2 R 683/9	AISI 1213
8	Packing gland	Stainless steel	X8CrNiS18-9 10088	Type 17 683/13	AISI 303
9	Packing washer	Aluminium			
10	O-ring	Cloroprene (Neoprene)			
11	Spring loaded Teflon ring	PTFE			
12	Bolts	Stainless steel	A2-70	A2-70	Type 308
13	Gasket	Fiber, Non-asbestos			
14	Handwheel	Steel			
17	Cap	Aluminium			
18	Gasket for cap	Nylon			
20	Identification ring	Stainless steel			
21	Disk spring	Steel			

## Shut-off valve, type SVA-S and SVA-L

Figure 13: SVA-L 15 - 40 (½ - 1½ in.)

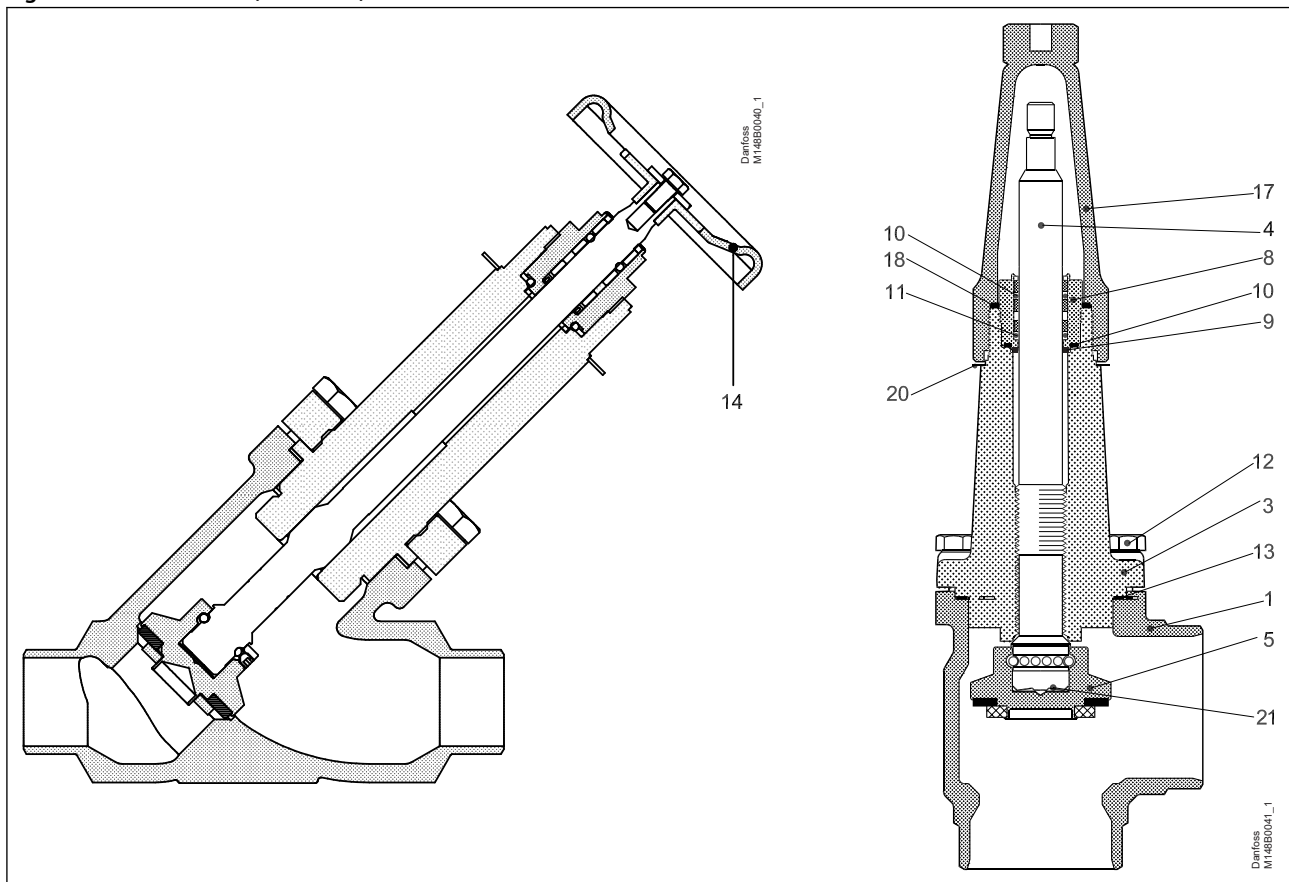

Table 14: Material and parts list

No.	Part	Material	EN	ISO	ASTM
1	Housing	Steel	G20Mn5QT, 10213-3 P285QH+QT, 10222-4		LCC, A352 LF2, A350
3	Valve bonnet	Steel	G20Mn5QT, 10213-3 P285QH+QT, 10222-4		LCC, A352 LF2, A350
4	Spindle	Stainless steel	X8CrNiS18-9 10088	Type 17 683/13	AISI 303
5	Cone	Steel	11SMn30 10087	Type 2 R 683/9	AISI 1213
8	Packing gland	Stainless steel	X8CrNiS18-9 10088	Type 17 683/13	AISI 303
9	Packing washer	Aluminium			
10	O-ring	Chloroprene (Neoprene)			
11	Spring loaded Teflon ring	PTFE			
12	Bolts	Stainless steel	A2-70	A2-70	Type 308
13	Gasket	Fiber, Non-asbestos			
14	Hand wheel	Steel			
17	Cap	Aluminium			
18	Gasket for cap	Nylon (PA6)			
20	Identification ring	Stainless steel			
21	Disk spring	Steel			

## Shut-off valve, type SVA-S and SVA-L

Figure 14: SVA-S 50-65 (2 - 2½ in.)

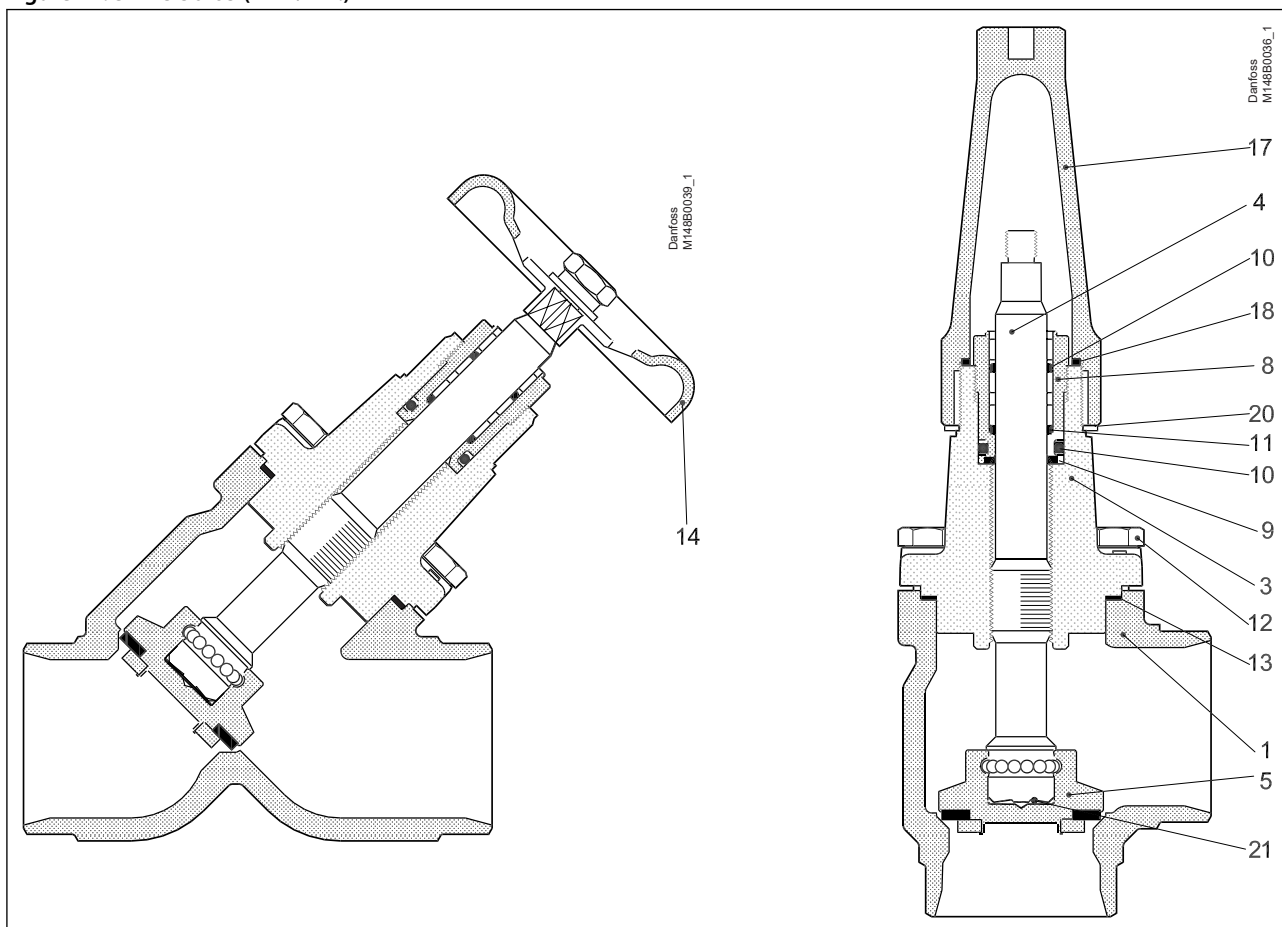

Table 15: Material and parts list

No.	Part	Material	EN	ISO	ASTM
1	Housing	Steel	G20Mn5QT, 10213-3 P285QH+QT, 10222-4		LCC, A352 LF2, A350
3	Valve bonnet	Steel	G20Mn5QT, 10213-3 P285QH+QT, 10222-4		LCC, A352 LF2, A350
4	Spindle	Stainless steel	X8CrNiS18-9 10088 DIN 17440 (SVA-SS only)	Type 17 683/13	AISI 303
5	Cone	Steel	11SMn30 10087	Type 2 R 683/9	AISI 1213
8	Packing gland	Stainless steel	X8CrNiS18-9 10088	Type 17 683/13	AISI 303
9	Packing washer	Aluminium			
10	O-ring	Cloroprene (Neoprene)			
11	Spring loaded Teflon ring	PTFE			
12	Bolts	Stainless steel	A2-70	A2-70	Type 308
13	Gasket	Fiber, Non-asbestos			
14	Handwheel	Steel			
17	Cap	Aluminium			
18	Gasket for cap	Nylon			
19	Locking nut	Steel			
20	Identification ring	Stainless steel			
21	Disk spring	Steel			

## Shut-off valve, type SVA-S and SVA-L

Figure 15: SVA-S 80 - 150 (3 - 6 in.)

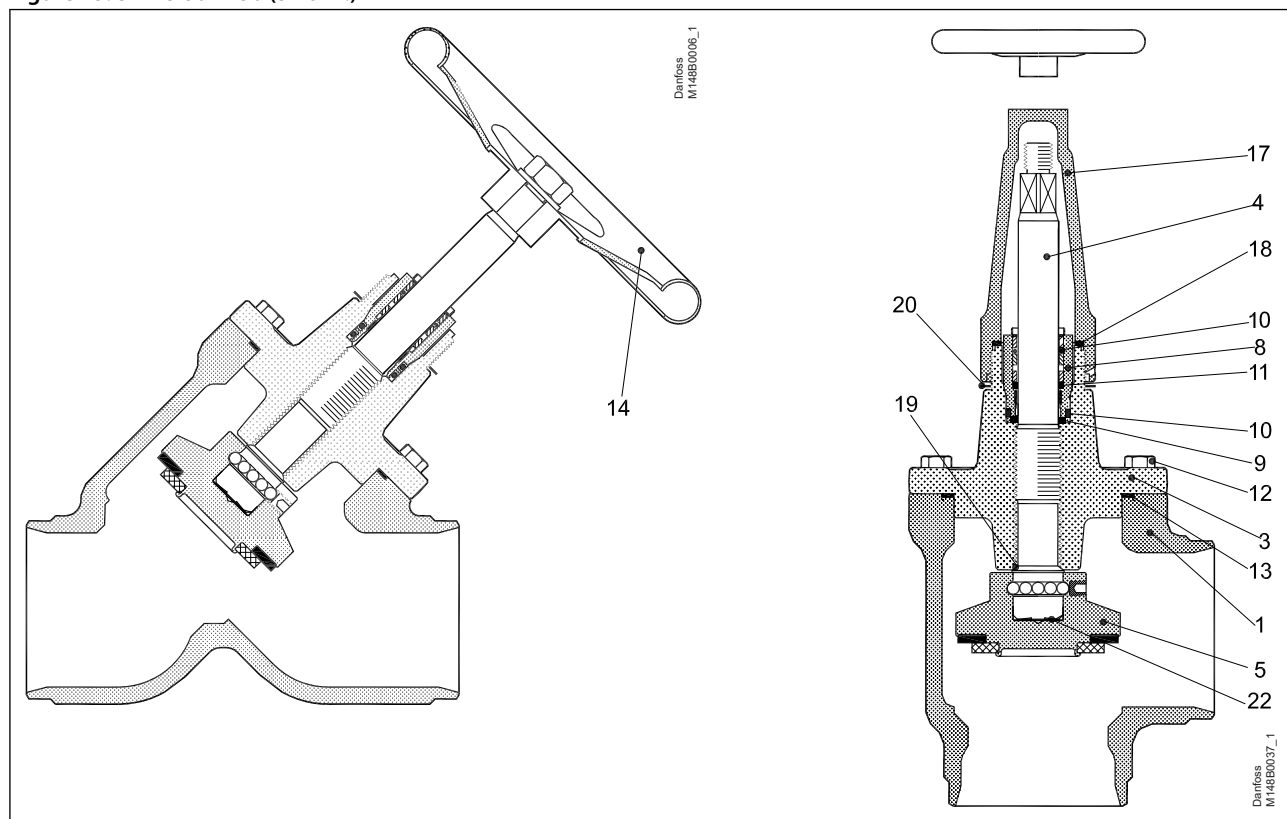

Table 16: Material and parts list

No.	Part	Material	EN	ISO	ASTM
1	Housing	Steel	G20Mn5QT 10213-3		LCC A352
3	Valve bonnet	Steel	SVA 80: G20Mn5QT SVA 100: P285QH+QT SVA 125: P285QH+QT SVA 150: P285QH+QT		SVA 80: LCC, A352 SVA 100: LF2, A350 SVA 125: LF2, A350 SVA 150: LF2, A350
4	Spindle	Stainless steel	X5CrNi18-10 10088	Type 11, R 683/13	AISI 304, A276
5	Cone seal	Steel Teflon (PTFE)	11SMn30 10087	Type 2, R 683/9	AISI 1213
8	Packing gland	Stainless steel	X8CrNiS18-9 10088	Type 17 R 683/13	AISI 303
9	Packing washer	Aluminium			
10	O-ring	Cloroprene (Neoprene)			
11	Spring loaded Teflon ring	PTFE			
12	Bolts	Stainless steel	A2-70	A2-70	Type 308
13	Gasket	Fiber, Non-asbestos			
14	Hand wheel	Steel			
17	Cap	Aluminium			
18	Gasket for cap	Nylon (PA 6)			
19	Soft backseat	Teflon (PTFE)			
20	Identification ring	Stainless steel			
22	Disk spring	Steel			

## Shut-off valve, type SVA-S and SVA-L

Figure 16: SVA-S 200 (8 in.)

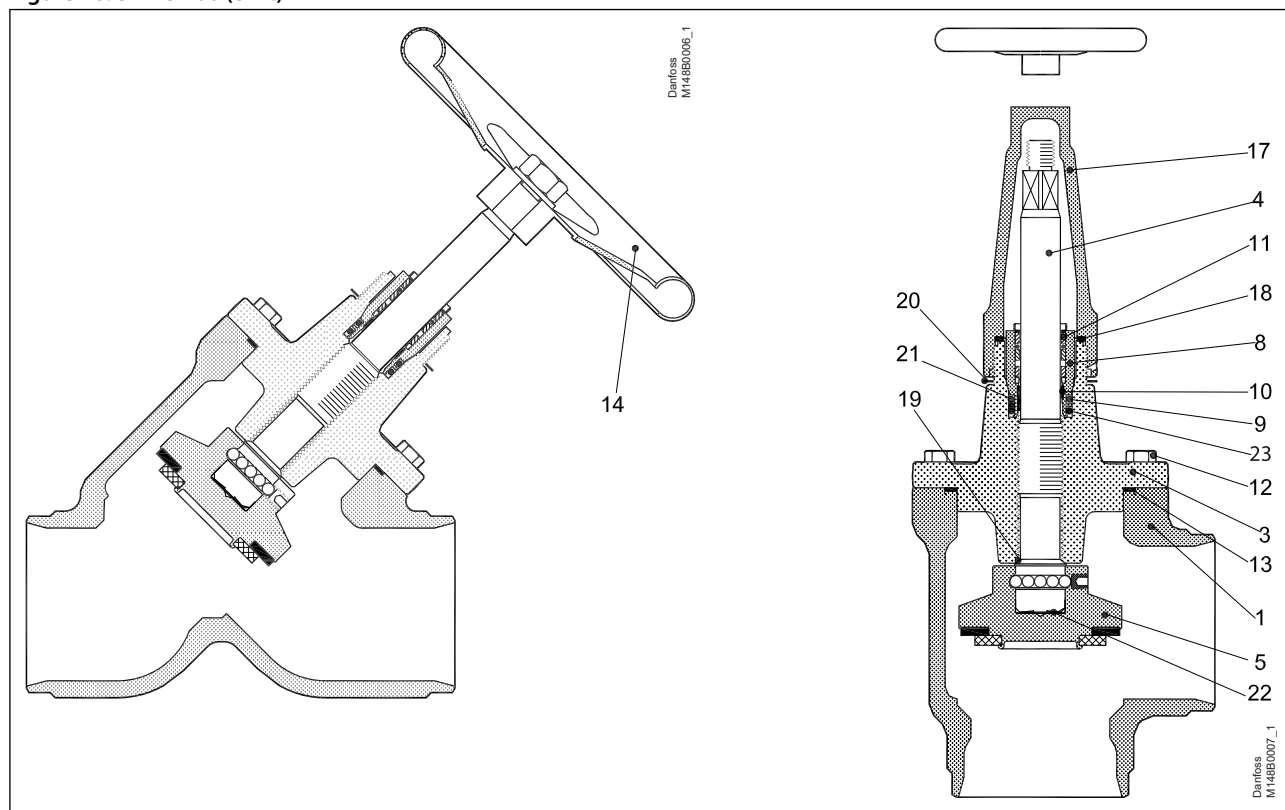

Table 17: Material and parts list

No.	Part	Material	EN	ISO	ASTM
1	Housing	Steel	G20Mn5QT 10213-3		LCC A352
3	Valve bonnet	Steel	G20Mn5QT, 10213-3 P285QH+QT, 10222-4		LCC, A352 LF2, A350
4	Spindle	Stainless steel	X5CrNi18-10 10088	Type 11, R 683/13	AISI 304, A276
5	Cone Cone seal	Steel Teflon (PTFE)	11SMn30 10087	Type 2, R 683/9	AISI 1213
8	Packing gland	Stainless steel	X8CrNiS18-9 10088	Type 17 R 683/13	AISI 303
9	O-ring	Cloroprene (Neoprene)			
10	Spring loaded Teflon ring	PTFE			
11	O-ring	Cloroprene (Neoprene)			
12	Bolts	Stainless steel	A2-70	A2-70	Type 308
13	Gasket	Fiber, Non-asbestos			
14	Hand wheel	Steel			
15	Washer	Stainless steel			
16	Nut	Stainless steel			
17	Cap	Aluminium			
18	Gasket for cap	Nylon (PA 6)			
19	Soft backseat	Teflon (PTFE)			
20	Identification ring	Stainless steel			
21	Wear ring	Teflon (PTFE)			
22	Disk spring	Steel			
23	O-ring	PTFE/Cloroprene (Neoprene)			

## Dimensions and weights

### SVA 6 -10 in angle execution with handwheel

Figure 17: SVA 6 -10 in angle execution with handwheel

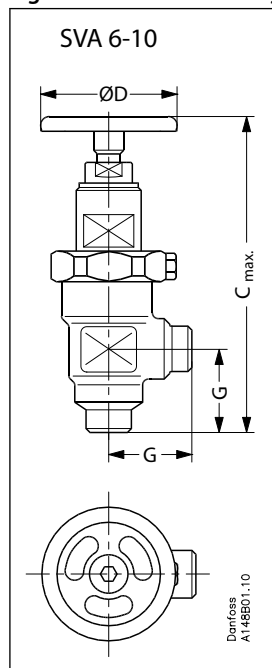

Table 18: SVA 6 -10

Valve size		$C_{max.}$	G	$\varnothing D$	Weight
SVA 6	mm	128	30	50	0.7 kg
	in.	5.04	1.18	1.97	1.54 lb
SVA 10	mm	173	45	60	1.4 kg
	in.	6.81	1.77	2.36	3.08 lb

**NOTE:**

Specified weights are approximate values only.

SVA 6 - 10 in angle execution with cap

Figure 18: SVA 6 - 10 in angle execution with cap

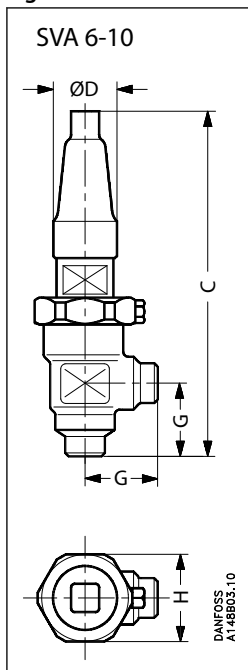

Table 19: SVA 6 - 10

Valve size		C	G	ØD	H	Weight
SVA 6	mm	139	30	30	48	0.8 kg
	in.	5.47	1.18	1.18	1.89	1.76 lb
SVA 10	mm	182	45	38	60	1.4 kg
	in.	7.17	1.77	1.50	2.36	3.08 lb

**NOTE:**

Specified weights are approximate values only.

SVA 6 - 10 in straight-way execution with handwheel / cap

Figure 19: SVA 6 - 10 with handwheel

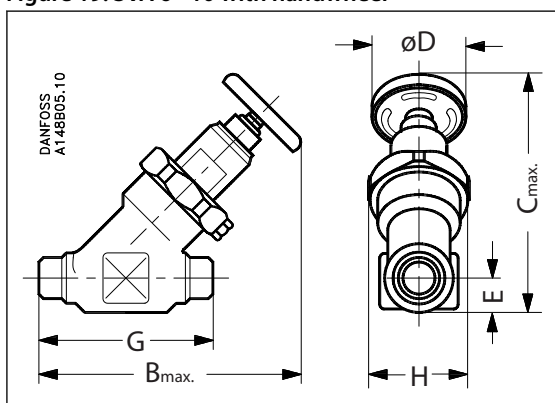

Figure 20: SVA 6 - 10 with cap

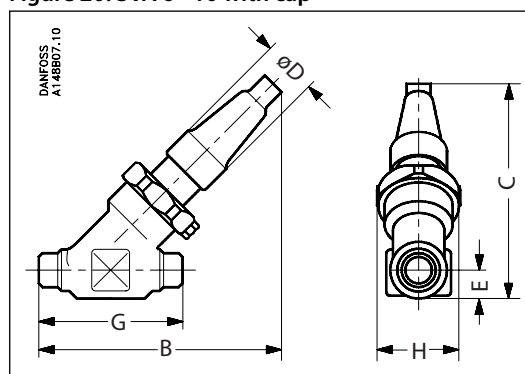

Table 20: SVA 6 - 10 in straight-way execution with handwheel

Valve size		C <sub>max.</sub>	B <sub>max.</sub>	E	G	ØD	H	Weight
SVA 6	mm	110	120	13	70	50	48	0.7 kg
	in.	4.33	4.72	0.49	2.76	1.97	1.89	1.54 lb
SVA 10	mm	145	160	20	120	60	60	2.0 kg
	in.	5.71	6.30	0.79	4.72	2.36	2.36	4.4 lb



## Shut-off valve, type SVA-S and SVA-L

**Table 21: SVA 6 - 10 in straight-way execution with cap**

Valve size		C	B	E	G	ØD	H	Weight
SVA 6	mm	110	120	13	70	30	48	0.8 kg
	in.	4.33	4.72	0.49	2.76	1.16	1.89	1.76 lb
SVA 10	mm	145	155	20	120	38	60	2.0 kg
	in.	5.71	6.10	0.79	4.72	1.50	2.36	4.4 lb

**NOTE:**

Specified weights are approximate values only.

## SVA 15 - 40 (½ - 1½ in.) in angleway version with cap / hand wheel

**Figure 21: SVA 15 - 40 (½ - 1½ in.) in angleway version with cap / hand wheel**

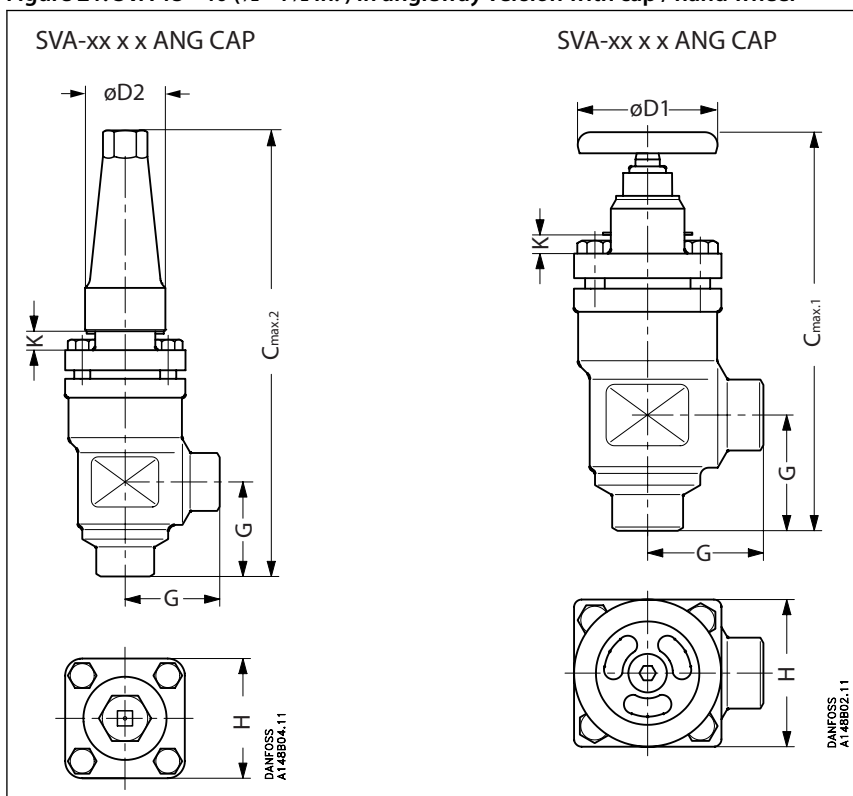

**Table 22: SVA-S**

Valve size		K	C <sub>max.1</sub>	C <sub>max.2</sub>	G	ØD <sub>1</sub>	ØD <sub>2</sub>	H	Weight
SVA 15 - 20	mm	4	178	189	45	60	38	60	1.4 kg
	in.	0.16	7.00	7.44	1.77	2.36	1.5	2.36	3.1 lb
SVA 25 - 40	mm	12	234	268	55	80	50	70	2.4 kg
	in.	0.47	9.21	10.55	2.17	3.15	1.97	2.76	5.3 lb

**Table 23: SVA-S, Socket weld**

Valve size		K	C <sub>max.1</sub>	C <sub>max.2</sub>	G	ØD <sub>1</sub>	ØD <sub>2</sub>	H	Weight
SVA 32 - 40	mm	12	241	275	62	80	50	70	2.9 kg
	in.	0.47	9.49	10.83	2.44	3.15	1.97	2.76	6.4 lb

**Table 24: SVA-L**

Valve size		K	C <sub>max.1</sub>	C <sub>max.2</sub>	G	ØD <sub>1</sub>	ØD <sub>2</sub>	H	Weight
SVA 15 - 20	mm	63	237	248	45	60	38	60	1.4 kg
	in.	2.48	9.33	9.76	1.77	2.36	1.5	2.36	3.1 lb
SVA 25 - 40	mm	74	296	330	55	80	50	70	2.4 kg
	in.	2.91	11.65	12.99	2.17	3.15	1.97	2.76	5.3 lb

**Table 25: SVA-L, Socket weld**

Valve size		K	C <sub>max.1</sub>	C <sub>max.2</sub>	G	ØD <sub>1</sub>	ØD <sub>2</sub>	H	Weight
SVA 32 - 40	mm	74	303	337	62	80	50	70	2.9 kg
	in.	2.91	11.93	13.27	2.44	3.15	1.97	2.76	6.4 lb

## Shut-off valve, type SVA-S and SVA-L

### NOTE:

Specified weights are approximate values only.

### SVA 15 - 40 (½ - 1½ in.) straightway version with cap / hand wheel

Figure 22: SVA-xx x x STR CAP

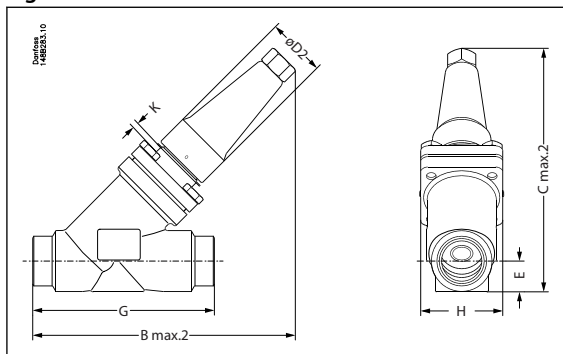

Figure 23: SVA-xx x x STR H-WHEEL

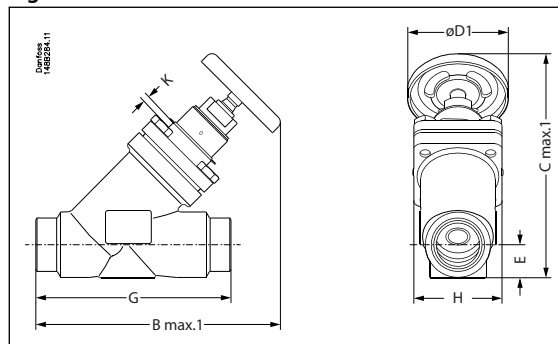

Table 26: SVA-S

Valve size		K	C <sub>max.1</sub>	C <sub>max.2</sub>	B <sub>max.1</sub>	B <sub>max.2</sub>	E	G	ØD <sub>1</sub>	ØD <sub>2</sub>	H	Weight
SVA 15 - 20	mm	4	146	141	160	156	20	120	60	38	60	2.0 kg
SVA (½ - ¾)	in.	0.16	5.74	5.55	6.30	6.14	0.79	4.72	2.36	1.5	2.36	4.4 lb
SVA 25 - 40	mm	12	199	208	212	222	26	155	80	50	70	3.0 kg
SVA (1 - 1½)	in.	0.47	7.83	8.19	8.35	8.74	1.02	6.10	3.15	1.97	2.76	6.6 lb

Table 27: SVA-S, Socket weld

Valve size		K	C <sub>max.1</sub>	C <sub>max.2</sub>	B <sub>max.1</sub>	B <sub>max.2</sub>	E	G	ØD <sub>1</sub>	ØD <sub>2</sub>	H	Weight
SVA 32	mm	12	200	209	212	222	27.4	155	80	50	70	3.0 kg
SVA (1¼)	in.	0.47	7.87	8.23	8.35	8.74	1.08	6.10	3.15	1.97	2.76	6.6 lb
SVA 40	mm	12	204	213	212	222	31.0	155	80	50	70	3.0 kg
SVA (1½)	in.	0.47	8.03	8.39	8.35	8.74	1.22	6.10	3.15	1.97	2.76	6.6 lb

Table 28: SVA-L

Valve size		K	C <sub>max.1</sub>	C <sub>max.2</sub>	B <sub>max.1</sub>	B <sub>max.2</sub>	E	G	ØD <sub>1</sub>	ØD <sub>2</sub>	H	Weight
SVA 15 - 20	mm	63	188	184	202	198	20	120	60	38	60	2.0 kg
SVA (½ - ¾)	in.	2.48	7.40	7.24	7.95	7.80	0.79	4.72	2.36	1.5	2.36	4.4 lb
SVA 25 - 40	mm	74	243	252	256	265	26	155	80	50	70	3.0 kg
SVA (1 - 1½)	in.	2.91	9.57	9.92	10.08	10.43	1.02	6.10	3.15	1.97	2.76	6.6 lb

Table 29: SVA-L, Socket weld

Valve size		K	C <sub>max.1</sub>	C <sub>max.2</sub>	B <sub>max.1</sub>	B <sub>max.2</sub>	E	G	ØD <sub>1</sub>	ØD <sub>2</sub>	H	Weight
SVA 32	mm	74	244	253	256	265	27.4	155	80	50	70	3.0 kg
SVA (1¼)	in.	2.91	9.61	9.96	10.08	10.43	1.08	6.10	3.15	1.97	2.76	6.6 lb
SVA 40	mm	74	248	257	256	265	31.0	155	80	50	70	3.0 kg
SVA (1½)	in.	2.91	9.76	10.12	10.08	10.43	1.22	6.10	3.15	1.97	2.76	6.6 lb

### NOTE:

Specified weights are approximate values only.

SVA 50 - 65 (2 - 2½ in.) in angleway version with cap / hand wheel

Figure 24: SVA-xx x x ANG CAP

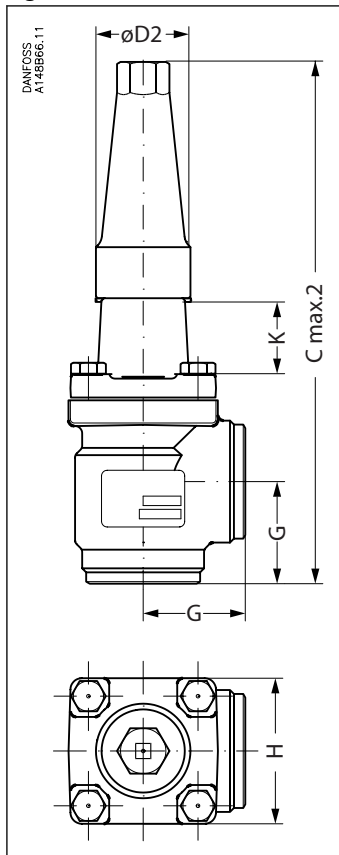

Figure 25: SVA-xx x x ANG H-WHEEL

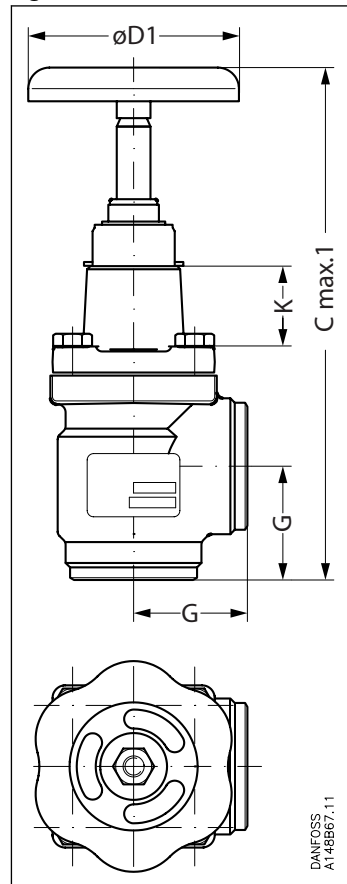

Table 30: SVA-S

Valve size	K	C <sub>max.1</sub>	C <sub>max.2</sub>	G	ØD <sub>1</sub>	ØD <sub>2</sub>	H	Weight	
SVA 50	mm	70	284	315	60	100	50	77	3.2 kg
SVA (2)	in.	2.76	11.18	12.40	2.36	3.94	1.97	3.03	7.1 lb
SVA 65	mm	70	310	335	70	100	50	90	4.8 kg
SVA (2½)	in.	2.76	12.20	13.19	2.76	3.94	1.97	3.54	10.6 lb

Table 31: SVA-S, Socket weld

Valve size	K	C <sub>max.1</sub>	C <sub>max.2</sub>	G	ØD <sub>1</sub>	ØD <sub>2</sub>	H	Weight	
SVA 50	mm	70	289	320	65	100	50	77	4.1 kg
SVA (2)	in.	2.76	11.38	12.60	2.56	3.94	1.97	3.03	9.0 lb

**NOTE:**

Specified weights are approximate values only.

SVA 50 - 65 (2 - 2½ in.) in straightway version with cap / hand wheel

Figure 26: SVA-xx x x STR CAP

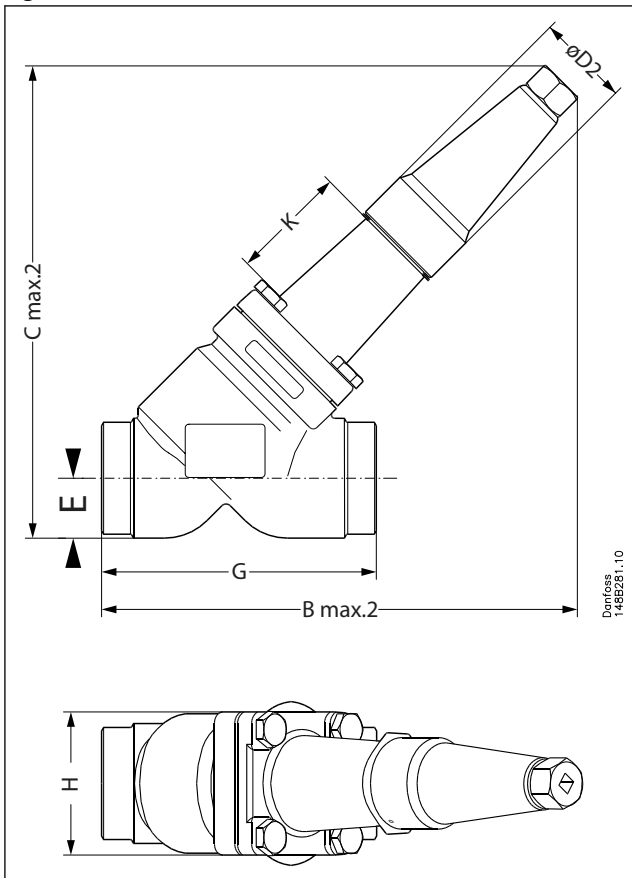

Figure 27: SVA-xx x x STR H-WHEEL

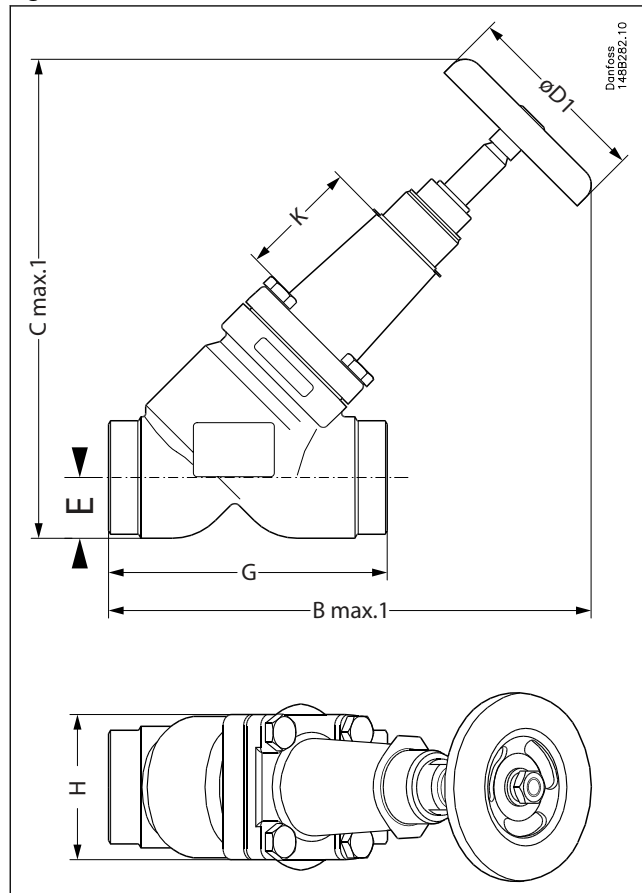

Table 32: SVA-S

Valve size		K	B <sub>max.1</sub>	B <sub>max.2</sub>	C <sub>max.1</sub>	C <sub>max.2</sub>	E	G	ØD <sub>1</sub>	ØD <sub>2</sub>	H	Weight
SVA 50	mm	70	259	259	257	257	32	148	100	50	77	4.2 kg
SVA (2)	in.	2.76	10.20	10.20	10.12	10.12	1.26	5.83	3.94	1.97	3.03	9.3 lb
SVA 65	mm	70	284	280	284	280	40	176	100	50	90	6.3 kg
SVA (2½)	in.	2.76	11.18	11.02	11.18	11.02	1.57	6.93	3.94	1.97	3.54	13.9 lb

Table 33: SVA-S, Socket weld

Valve size		K	B <sub>max.1</sub>	B <sub>max.2</sub>	C <sub>max.1</sub>	C <sub>max.2</sub>	E	G	ØD <sub>1</sub>	ØD <sub>2</sub>	H	Weight
SVA 50	mm	70	266	266	261	261	37	162	100	50	77	5.1 kg
SVA (2)	in.	2.76	10.47	10.47	10.28	10.28	1.26	6.38	3.94	1.97	3.03	11.2 lb

**i** NOTE:

Specified weights are approximate values only.

SVA 80 - 200 (3 - 8 in.) angleway version with cap / hand wheel

Figure 28: SVA-xx x x ANG CAP

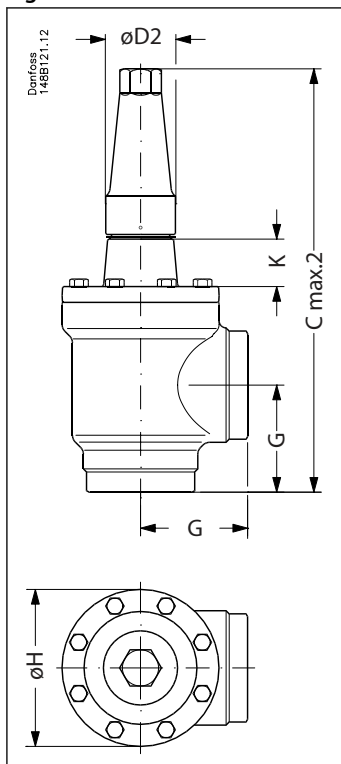

Figure 29: SVA-xx x x ANG H-WHEEL

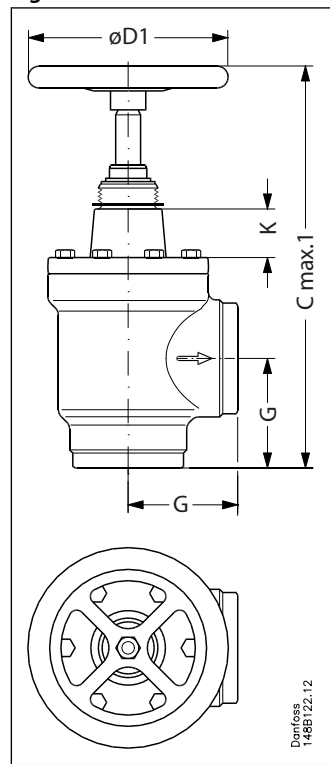

Table 34: SVA-S

Valve size		K	$C_{max.1}$	$C_{max.2}$	G	$\varnothing D_1$	$\varnothing D_2$	$\varnothing H$	Weight
SVA 80	mm	76	373	388	90	200	58	129	9.7 kg
SVA (3)	in.	3.00	14.69	15.28	3.54	7.87	2.28	5.08	21.4 lb
SVA 100	mm	90	432	437	106	250	58	156	15.3 kg
SVA (4)	in.	3.54	17.00	17.20	4.17	9.84	2.28	6.14	33.7 lb
SVA 125	mm	90	517	533	128	315	74	193	28.1 kg
SVA (5)	in.	3.54	20.35	20.98	5.04	12.40	2.91	7.60	61.9 lb
SVA 150	mm	90	564	568	145	315	74	219	39.7 kg
SVA (6)	in.	3.54	22.20	22.36	5.71	12.40	2.91	8.62	87.5 lb
SVA 200	mm	90	677	678	180	400	86	276	79.5 kg
SVA (8)	in.	3.54	26.63	26.69	7.09	15.75	3.39	10.87	175.3 lb

**NOTE:**

Specified weights are approximate values only.

SVA 80 - 200 (3 - 8 in.) straightway version with cap / hand wheel

Figure 30: SVA-xx x x STR CAP

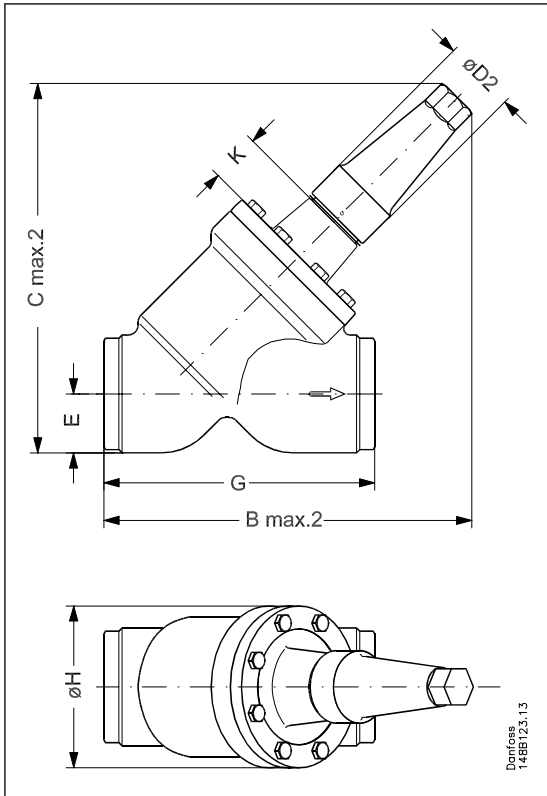

Figure 31: SVA-xx x x STR H-WHEEL

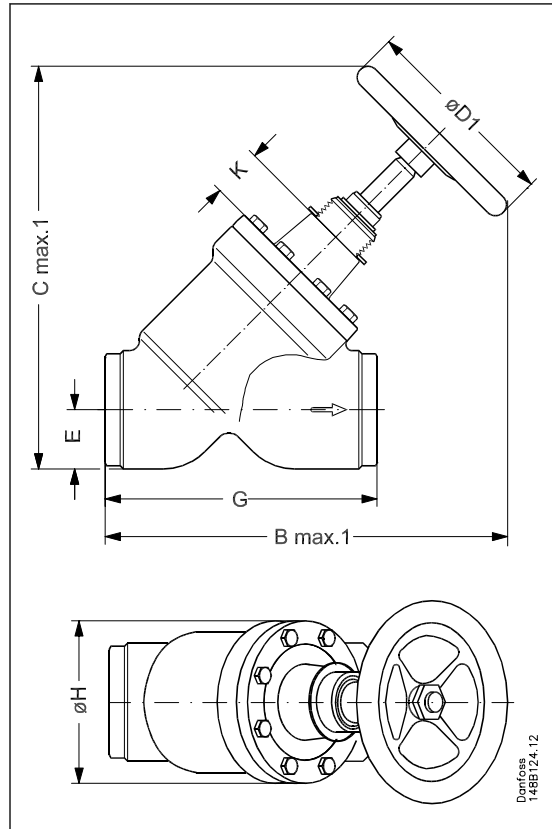

Table 35: SVA-S

Valve size		K	B <sub>max.1</sub>	B <sub>max.2</sub>	C <sub>max.1</sub>	C <sub>max.2</sub>	E	G	ØD <sub>1</sub>	ØD <sub>2</sub>	ØH	Weight
SVA 80	mm	76	365	321	367	322	48	216	200	58	129	10.9 kg
SVA (3)	in.	3.00	14.37	12.64	14.45	12.72	1.89	8.50	7.87	2.28	5.08	24.0 lb
SVA 100	mm	90	435	367	443	375	60	264	250	58	156	18.2 kg
SVA (4)	in.	3.54	17.13	14.45	17.44	14.76	2.36	10.39	9.84	2.28	6.14	40.1 lb
SVA 125	mm	90	526	444	538	456	74	322	315	74	193	32.8 kg
SVA (5)	in.	3.54	20.71	17.48	21.18	17.95	2.91	12.68	12.40	2.91	7.60	72.3 lb
SVA 150	mm	90	572	483	594	505	91	370	315	74	219	60.0 kg
SVA (6)	in.	3.54	22.52	19.02	23.39	19.88	3.58	14.57	12.40	2.91	8.62	132.3 lb
SVA 200	mm	90	692	579	726	613	117	464	400	86	276	111.5 kg
SVA (8)	in.	3.54	27.24	22.80	28.58	24.13	4.61	18.27	15.75	3.39	10.87	245.8 lb

**NOTE:**

Specified weights are approximate values only.

## Ordering

Available connection sizes

**SVA-S:**

The **S** means Standard bonnet length (sizes from DN50 to DN200 are insulation friendly)

**SVA-L:**

The **L** means Long bonnet length (insulation friendly)

**Table 36: Connection sizes**

Size	SVA-S	SVA-L
6	x	
10	x	
15	x	x
20	x	x
25	x	x
32	x	x
40	x	x
50	x	
65	x	
80	x	
100	x	
125	x	
150	x	
200	x	

Please note that the type codes only serve to identify the valves, some of which may not form part of the standard product range. For further information please contact your local Danfoss Sales Company.

**Table 37: Type codes**

Valve type	SVA	Shut-off valve					
		Available connections					
		A/D	G	SOC		FPT	T
Nominal size in mm (valve size measured on the connection diameter)	6	DN 6 (¼)	x				x
	10	DN 10 (⅜)	x	x			
	15	DN 15 (½)	x	x	x		x
	20	DN 20 (¾)	x	x	x	x <sup>(1)</sup>	x
	25	DN 25 (1)	x	x	x		x
	32	DN 32 (1¼)	x	x	x		x
	40	DN 40 (1½)	x	x	x		
	50	DN 50 (2)	x	x	x		
	65	DN 65 (2½)	x				
	80	DN 80 (3)	x				
	100	DN 100 (4)	x	x			
	125	DN 125 (5)	x	x			
	150	DN 150 (6)	x	x			
	200	DN 200 (8)	x				
Connections	A	Butt-weld connection: ANSI B 36.10 schedule 80, DN 15 - 40 (½ - 1½ in.) Butt-weld connection: ANSI B 36.10 schedule 40, DN 50 - 200 (2 - 8 in.)					
	D	Butt-weld connection: DIN EN 10220					
	G	Butt-weld connection: GOST (8734-75 and 8732-78)					
	SOC	Socket weld: ANSI B 16.11					
	FPT	Female Pipe Thread NPT: ANSI/ASME B 1.20.1					
	T	Outside threaded connections ISO 228/1 Pipe thread					
Valve housing	ANG STR	Angle flow Straight flow					
Other equipment	H-WHEEL CAP	Hand wheel Cap					

## Shut-off valve, type SVA-S and SVA-L

<sup>(1)</sup> Special combination SOC-inlet, FPT outlet

### ❗ IMPORTANT:

Where products need to be certified according to specific certification societies or where higher pressures are required, the relevant information should be included at the time of order.

### Ordering SVA-S complete valves

#### Example:

SVA-S 20 DIN angleway with hand wheel = 148B5300

### ❗ IMPORTANT:

Where products need to be certified according to specific certification societies or where higher pressures are required, the relevant information should be included at the time of order.

**Table 38: SVA-S Angleway - Butt-weld DIN (EN 10220)**

Size		Type	MWP		Code number
mm	in.		bar	psi	
6	¼	SVA-S 6 D ANG H-WHEEL	52	754	148B5000
6	¼	SVA-S 6 D ANG CAP	52	754	148B5001
10	⅜	SVA-S 10 D ANG H-WHEEL	52	754	148B5100
10	⅜	SVA-S 10 D ANG CAP	52	754	148B5101
15	½	SVA-S 15 D ANG H-WHEEL	52	754	148B5200
15	½	SVA-S 15 D ANG CAP	52	754	148B5201
20	¾	SVA-S 20 D ANG H-WHEEL	52	754	148B5300
20	¾	SVA-S 20 D ANG CAP	52	754	148B5301
25	1	SVA-S 25 D ANG H-WHEEL	52	754	148B5400
25	1	SVA-S 25 D ANG CAP	52	754	148B5401
32	1¼	SVA-S 32 D ANG H-WHEEL	52	754	148B5500
32	1¼	SVA-S 32 D ANG CAP	52	754	148B5501
40	1½	SVA-S 40 D ANG H-WHEEL	52	754	148B5600
40	1½	SVA-S 40 D ANG CAP	52	754	148B5601
50	2	SVA-S 50 D ANG H-WHEEL	52	754	148B5700
50	2	SVA-S 50 D ANG CAP	52	754	148B5701
65	2½	SVA-S 65 D ANG H-WHEEL	52	754	148B5800
65	2½	SVA-S 65 D ANG CAP	52	754	148B5801
80	3	SVA-S 80 D ANG H-WHEEL	52	754	148B5900
80	3	SVA-S 80 D ANG CAP	52	754	148B5901
100	4	SVA-S 100 D ANG H-WHEEL	52	754	148B6000
100	4	SVA-S 100 D ANG CAP	52	754	148B6001
125	5	SVA-S 125 D ANG H-WHEEL	52	754	148B6100
125	5	SVA-S 125 D ANG CAP	52	754	148B6101
150	6	SVA-S 150 D ANG H-WHEEL	52	754	148B6200
150	6	SVA-S 150 D ANG CAP	52	754	148B6201
200	8	SVA-S 200 D ANG H-WHEEL	52	754	148B6300
200	8	SVA-S 200 D ANG CAP	52	754	148B6301

**Table 39: SVA-S Straightway - Butt-weld DIN (EN 10220)**

Size		Type	MWP		Code number
mm	in.		bar	psi	
6	¼	SVA-S 6 D STR H-WHEEL	52	754	148B5010
6	¼	SVA-S 6 D STR CAP	52	754	148B5011
10	⅜	SVA-S 10 D STR H-WHEEL	52	754	148B5110
10	⅜	SVA-S 10 D STR CAP	52	754	148B5111
15	½	SVA-S 15 D STR H-WHEEL	52	754	148B5210
15	½	SVA-S 15 D STR CAP	52	754	148B5211
20	¾	SVA-S 20 D STR H-WHEEL	52	754	148B5310
20	¾	SVA-S 20 D STR CAP	52	754	148B5311
25	1	SVA-S 25 D STR H-WHEEL	52	754	148B5410
25	1	SVA-S 25 D STR CAP	52	754	148B5411



## Shut-off valve, type SVA-S and SVA-L

Size		Type	MWP		Code number
mm	in.		bar	psi	
32	1¼	SVA-S 32 D STR H-WHEEL	52	754	148B5510
32	1¼	SVA-S 32 D STR CAP	52	754	148B5511
40	1½	SVA-S 40 D STR H-WHEEL	52	754	148B5610
40	1½	SVA-S 40 D STR CAP	52	754	148B5611
50	2	SVA-S 50 D STR H-WHEEL	52	754	148B5710
50	2	SVA-S 50 D STR CAP	52	754	148B5711
65	2½	SVA-S 65 D STR H-WHEEL	52	754	148B5810
65	2½	SVA-S 65 D STR CAP	52	754	148B5811
80	3	SVA-S 80 D STR H-WHEEL	52	754	148B5910
80	3	SVA-S 80 D STR CAP	52	754	148B5911
100	4	SVA-S 100 D STR H-WHEEL	52	754	148B6010
100	4	SVA-S 100 D STR CAP	52	754	148B6011
125	5	SVA-S 125 D STR H-WHEEL	52	754	148B6110
125	5	SVA-S 125 D STR CAP	52	754	148B6111
150	6	SVA-S 150 D STR H-WHEEL	52	754	148B6210
150	6	SVA-S 150 D STR CAP	52	754	148B6211
200	8	SVA-S 200 D STR H-WHEEL	52	754	148B6310
200	8	SVA-S 200 D STR CAP	52	754	148B6311

**Table 40: SVA-S Angleway - Butt-weld ANSI (B 36.10 Schedule 80)**

Size		Type	MWP		Code number
mm	in.		bar	psi	
6	¼	SVA-S 6 A ANG H-WHEEL	52	754	148B5020
6	¼	SVA-S 6 A ANG CAP	52	754	148B5021
10	⅜	SVA-S 10 A ANG H-WHEEL	52	754	148B5120
10	⅜	SVA-S 10 A ANG CAP	52	754	148B5121
15	½	SVA-S 15 A ANG H-WHEEL	52	754	148B5220
15	½	SVA-S 15 A ANG CAP	52	754	148B5221
20	¾	SVA-S 20 A ANG H-WHEEL	52	754	148B5320
20	¾	SVA-S 20 A ANG CAP	52	754	148B5321
25	1	SVA-S 25 A ANG H-WHEEL	52	754	148B5420
25	1	SVA-S 25 A ANG CAP	52	754	148B5421
32	1¼	SVA-S 32 A ANG H-WHEEL	52	754	148B5520
32	1¼	SVA-S 32 A ANG CAP	52	754	148B5521
40	1½	SVA-S 40 A ANG H-WHEEL	52	754	148B5620
40	1½	SVA-S 40 A ANG CAP	52	754	148B5621

**Table 41: SVA-S Straightway - Butt-weld ANSI (B 36.10 Schedule 80)**

Size		Type	MWP		Code number
mm	in.		bar	psi	
6	¼	SVA-S 6 A STR H-WHEEL	52	754	148B5030
6	¼	SVA-S 6 A STR CAP	52	754	148B5031
10	⅜	SVA-S 10 A STR H-WHEEL	52	754	148B5130
10	⅜	SVA-S 10 A STR CAP	52	754	148B5131
15	½	SVA-S 15 A STR H-WHEEL	52	754	148B5230
15	½	SVA-S 15 A STR CAP	52	754	148B5231
20	¾	SVA-S 20 A STR H-WHEEL	52	754	148B5330
20	¾	SVA-S 20 A STR CAP	52	754	148B5331
25	1	SVA-S 25 A STR H-WHEEL	52	754	148B5430
25	1	SVA-S 25 A STR CAP	52	754	148B5431
32	1¼	SVA-S 32 A STR H-WHEEL	52	754	148B5530
32	1¼	SVA-S 32 A STR CAP	52	754	148B5531
40	1½	SVA-S 40 A STR H-WHEEL	52	754	148B5630
40	1½	SVA-S 40 A STR CAP	52	754	148B5631

## Shut-off valve, type SVA-S and SVA-L

**Table 42: SVA-S Angleway - Butt-weld ANSI (B 36.10 Schedule 40)**

Size		Type	MWP		Code number
mm	in.		bar	psi	
50	2	SVA-S 50 A ANG H-WHEEL	52	754	14885720
50	2	SVA-S 50 A ANG CAP	52	754	14885721
65	2½	SVA-S 65 A ANG H-WHEEL	52	754	14885820
65	2½	SVA-S 65 A ANG CAP	52	754	14885821
80	3	SVA-S 80 A ANG H-WHEEL	52	754	14885920
80	3	SVA-S 80 A ANG CAP	52	754	14885921
100	4	SVA-S 100 A ANG H-WHEEL	52	754	14886020
100	4	SVA-S 100 A ANG CAP	52	754	14886021
125	5	SVA-S 125 A ANG H-WHEEL	52	754	14886120
125	5	SVA-S 125 A ANG CAP	52	754	14886121
150	6	SVA-S 150 A ANG H-WHEEL	52	754	14886220
150	6	SVA-S 150 A ANG CAP	52	754	14886221
200	8	SVA-S 200 A ANG H-WHEEL	52	754	14886320
200	8	SVA-S 200 A ANG CAP	52	754	14886321

**Table 43: SVA-S Straightway - Butt-weld ANSI (B 36.10 Schedule 40)**

Size		Type	MWP		Code number
mm	in.		bar	psi	
50	2	SVA-S 50 A STR H-WHEEL	52	754	14885730
50	2	SVA-S 50 A STR CAP	52	754	14885731
65	2½	SVA-S 65 A STR H-WHEEL	52	754	14885830
65	2½	SVA-S 65 A STR CAP	52	754	14885831
80	3	SVA-S 80 A STR H-WHEEL	52	754	14885930
80	3	SVA-S 80 A STR CAP	52	754	14885931
100	4	SVA-S 100 A STR H-WHEEL	52	754	14886030
100	4	SVA-S 100 A STR CAP	52	754	14886031
125	5	SVA-S 125 A STR H-WHEEL	52	754	14886130
125	5	SVA-S 125 A STR CAP	52	754	14886131
150	6	SVA-S 150 A STR H-WHEEL	52	754	14886230
150	6	SVA-S 150 A STR CAP	52	754	14886231
200	8	SVA-S 200 A STR H-WHEEL	52	754	14886330
200	8	SVA-S 200 A STR CAP	52	754	14886331

**Table 44: SVA-S Angleway - Butt-weld, GOST**

Size		Type	MWP		Code number
mm	in.		bar	psi	
150	6	SVA-S 150 G ANG H-WHEEL	52	754	14886240
150	6	SVA-S 150 G ANG CAP	52	754	14886241

**Table 45: SVA-S Straightway - Butt-weld, GOST**

Size		Type	MWP		Code number
mm	in.		bar	psi	
150	6	SVA-S 150 G STR H-WHEEL	52	754	14886250
150	6	SVA-S 150 G STR CAP	52	754	14886251

**Table 46: SVA-S Angleway - Socket welding ANSI (B 16.11)**

Size		Type	MWP		Code number
mm	in.		bar	psi	
15	½	SVA-S 15 SOC ANG H-WHEEL	52	754	14885222
15	½	SVA-S 15 SOC ANG CAP	52	754	14885223
20	¾	SVA-S 20 SOC ANG H-WHEEL	52	754	14885322
20	¾	SVA-S 20 SOC ANG CAP	52	754	14885323
25	1	SVA-S 25 SOC ANG H-WHEEL	52	754	14885422
25	1	SVA-S 25 SOC ANG CAP	52	754	14885423
32	1¼	SVA-S 32 SOC ANG H-WHEEL	52	754	14885522
32	1¼	SVA-S 32 SOC ANG CAP	52	754	14885523
40	1½	SVA-S 40 SOC ANG H-WHEEL	52	754	14885622

## Shut-off valve, type SVA-S and SVA-L

Size		Type	MWP		Code number
mm	in.		bar	psi	
40	1½	SVA-S 40 SOC ANG CAP	52	754	148B5623
50	2	SVA-S 50 SOC ANG H-WHEEL	52	754	148B5722
50	2	SVA-S 50 SOC ANG CAP	52	754	148B5723

**Table 47: SVA-S Straightway - Socket welding ANSI (B 16.11)**

Size		Type	MWP		Code number
mm	in.		bar	psi	
15	½	SVA-S 15 SOC STR H-WHEEL	52	754	148B5232
15	½	SVA-S 15 SOC STR CAP	52	754	148B5233
20	¾	SVA-S 20 SOC STR H-WHEEL	52	754	148B5332
20	¾	SVA-S 20 SOC STR CAP	52	754	148B5333
25	1	SVA-S 25 SOC STR H-WHEEL	52	754	148B5432
25	1	SVA-S 25 SOC STR CAP	52	754	148B5433
32	1¼	SVA-S 32 SOC STR H-WHEEL	52	754	148B5532
32	1¼	SVA-S 32 SOC STR CAP	52	754	148B5533
40	1½	SVA-S 40 SOC STR H-WHEEL	52	754	148B5632
40	1½	SVA-S 40 SOC STR CAP	52	754	148B5633
50	2	SVA-S 50 SOC STR H-WHEEL	52	754	148B5732
50	2	SVA-S 50 SOC STR CAP	52	754	148B5733

**Table 48: SVA-S Angleway - FPT inside pipe thread, NPT (ANSI/ASME B 1.20.1)**

Size		Type	MWP		Code number
mm	in.		bar	psi	
15	½	SVA-S 15 FPT ANG H-WHEEL	52	754	148B5224
15	½	SVA-S 15 FPT ANG CAP	52	754	148B5225
20	¾	SVA-S 20 FPT ANG H-WHEEL	52	754	148B5324
20	¾	SVA-S 20 FPT ANG CAP	52	754	148B5325
25	1	SVA-S 25 FPT ANG H-WHEEL	52	754	148B5424
25	1	SVA-S 25 FPT ANG CAP	52	754	148B5425
32	1¼	SVA-S 32 FPT ANG H-WHEEL	52	754	148B5524
32	1¼	SVA-S 32 FPT ANG CAP	52	754	148B5525

**Table 49: SVA-S Straightway - FPT inside pipe thread, NPT (ANSI/ASME B 1.20.1)**

Size		Type	MWP		Code number
mm	in.		bar	psi	
15	½	SVA-S 15 FPT STR H-WHEEL	52	754	148B5234
15	½	SVA-S 15 FPT STR CAP	52	754	148B5235
20	¾	SVA-S 20 FPT STR H-WHEEL	52	754	148B5334
20	¾	SVA-S 20 FPT STR CAP	52	754	148B5335
25	1	SVA-S 25 FPT STR H-WHEEL	52	754	148B5434
25	1	SVA-S 25 FPT STR CAP	52	754	148B5435
32	1¼	SVA-S 32 FPT STR H-WHEEL	52	754	148B5534
32	1¼	SVA-S 32 FPT STR CAP	52	754	148B5535

**Table 50: SVA-S Angleway - T outside pipe thread, (ISO 228/1)**

Size		Type	MWP		Code number
mm	in.		bar	psi	
6	¼	SVA-S 6 T ANG CAP	52	754	148B5032

**Table 51: SVA-S Straightway - Socket welding ANSI (B 16.11) inlet, FPT inside pipe thread, NPT (ANSI/ASME B 1.20.1) outlet**

Size		Type	MWP		Code number
mm	in.		bar	psi	
20	¾	SVA-S 20 SOC/FPT STR H-WHEEL	52	754	148B6790
20	¾	SVA-S 20 SOC/FPT STR CAP	52	754	148B6792

## Shut-off valve, type SVA-S and SVA-L

**Table 52: SVA-S Angleway - Socket welding ANSI (B 16.11) inlet, FPT inside pipe thread, NPT (ANSI/ASME B 1.20.1) outlet**

Size		Type	MWP		Code number
mm	in.		bar	psi	
20	¾	SVA-S 20 SOC/FPT ANG H-WHEEL	52	754	148B6789
20	¾	SVA-S 20 SOC/FPT ANG CAP	52	754	148B6791

**ANG** = Angleway

**STR** = Straightway

**CAP** = Cap

**H-WHEEL** = Hand wheel

### Ordering SVA-L complete valves

**Example:**

SVA-L 20 DIN angleway with hand wheel = 148B5340

**! IMPORTANT:**

Where products need to be certified according to specific certification societies or where higher pressures are required, the relevant information should be included at the time of order.

**Table 53: SVA-L Angleway - Butt-weld DIN (EN 10220)**

Size		Type	MWP		Code number
mm	in.		bar	psi	
15	½	SVA-L 15 D ANG H-WHEEL	52	754	148B5240
15	½	SVA-L 15 D ANG CAP	52	754	148B5241
20	¾	SVA-L 20 D ANG H-WHEEL	52	754	148B5340
20	¾	SVA-L 20 D ANG CAP	52	754	148B5341
25	1	SVA-L 25 D ANG H-WHEEL	52	754	148B5440
25	1	SVA-L 25 D ANG CAP	52	754	148B5441
32	1¼	SVA-L 32 D ANG H-WHEEL	52	754	148B5540
32	1¼	SVA-L 32 D ANG CAP	52	754	148B5541
40	1½	SVA-L 40 D ANG H-WHEEL	52	754	148B5640
40	1½	SVA-L 40 D ANG CAP	52	754	148B5641

**Table 54: SVA-L Straightway - Butt-weld DIN (EN 10220)**

Size		Type	MWP		Code number
mm	in.		bar	psi	
15	½	SVA-L 15 D STR H-WHEEL	52	754	148B5250
15	½	SVA-L 15 D STR CAP	52	754	148B5251
20	¾	SVA-L 20 D STR H-WHEEL	52	754	148B5350
20	¾	SVA-L 20 D STR CAP	52	754	148B5351
25	1	SVA-L 25 D STR H-WHEEL	52	754	148B5450
25	1	SVA-L 25 D STR CAP	52	754	148B5451
32	1¼	SVA-L 32 D STR H-WHEEL	52	754	148B5550
32	1¼	SVA-L 32 D STR CAP	52	754	148B5551
40	1½	SVA-L 40 D STR H-WHEEL	52	754	148B5650
40	1½	SVA-L 40 D STR CAP	52	754	148B5651

**Table 55: SVA-L Angleway - Butt-weld ANSI (B 36.10 Schedule 80)**

Size		Type	MWP		Code number
mm	in.		bar	psi	
15	½	SVA-L 15 A ANG H-WHEEL	52	754	148B5260
15	½	SVA-L 15 A ANG CAP	52	754	148B5261
20	¾	SVA-L 20 A ANG H-WHEEL	52	754	148B5360
20	¾	SVA-L 20 A ANG CAP	52	754	148B5361
25	1	SVA-L 25 A ANG H-WHEEL	52	754	148B5460
25	1	SVA-L 25 A ANG CAP	52	754	148B5461
32	1¼	SVA-L 32 A ANG H-WHEEL	52	754	148B5560

## Shut-off valve, type SVA-S and SVA-L

Size		Type	MWP		Code number
mm	in.		bar	psi	
32	1¼	SVA-L 32 A ANG CAP	52	754	148B5561
40	1½	SVA-L 40 A ANG H-WHEEL	52	754	148B5660
40	1½	SVA-L 40 A ANG CAP	52	754	148B5661

**Table 56: SVA-L Straightway - Butt-weld ANSI (B 36.10 Schedule 80)**

Size		Type	MWP		Code number
mm	in.		bar	psi	
15	½	SVA-L 15 A STR H-WHEEL	52	754	148B5270
15	½	SVA-L 15 A STR CAP	52	754	148B5271
20	¾	SVA-L 20 A STR H-WHEEL	52	754	148B5370
20	¾	SVA-L 20 A STR CAP	52	754	148B5371
25	1	SVA-L 25 A STR H-WHEEL	52	754	148B5470
25	1	SVA-L 25 A STR CAP	52	754	148B5471
32	1¼	SVA-L 32 A STR H-WHEEL	52	754	148B5570
32	1¼	SVA-L 32 A STR CAP	52	754	148B5571
40	1½	SVA-L 40 A STR H-WHEEL	52	754	148B5670
40	1½	SVA-L 40 A STR CAP	52	754	148B5671

**Table 57: SVA-L Angleway - Socket welding ANSI (B 16.11)**

Size		Type	MWP		Code number
mm	in.		bar	psi	
15	½	SVA-L 15 SOC ANG H-WHEEL	52	754	148B5262
15	½	SVA-L 15 SOC ANG CAP	52	754	148B5263
20	¾	SVA-L 20 SOC ANG H-WHEEL	52	754	148B5362
20	¾	SVA-L 20 SOC ANG CAP	52	754	148B5363
25	1	SVA-L 25 SOC ANG H-WHEEL	52	754	148B5462
25	1	SVA-L 25 SOC ANG CAP	52	754	148B5463
32	1¼	SVA-L 32 SOC ANG H-WHEEL	52	754	148B5562
32	1¼	SVA-L 32 SOC ANG CAP	52	754	148B5563
40	1½	SVA-L 40 SOC ANG H-WHEEL	52	754	148B5662
40	1½	SVA-L 40 SOC ANG CAP	52	754	148B5663

**Table 58: SVA-L Straightway - Socket welding ANSI (B 16.11)**

Size		Type	MWP		Code number
mm	in.		bar	psi	
15	½	SVA-L 15 SOC STR H-WHEEL	52	754	148B5272
15	½	SVA-L 15 SOC STR CAP	52	754	148B5273
20	¾	SVA-L 20 SOC STR H-WHEEL	52	754	148B5372
20	¾	SVA-L 20 SOC STR CAP	52	754	148B5373
25	1	SVA-L 25 SOC STR H-WHEEL	52	754	148B5472
25	1	SVA-L 25 SOC STR CAP	52	754	148B5473
32	1¼	SVA-L 32 SOC STR H-WHEEL	52	754	148B5572
32	1¼	SVA-L 32 SOC STR CAP	52	754	148B5573
40	1½	SVA-L 40 SOC STR H-WHEEL	52	754	148B5672
40	1½	SVA-L 40 SOC STR CAP	52	754	148B5673

**Table 59: SVA-L Angleway - FPT inside pipe thread, NPT (ANSI/ASME B 1.20.1)**

Size		Type	MWP		Code number
mm	in.		bar	psi	
15	½	SVA-L 15 FPT ANG H-WHEEL	52	754	148B5264
15	½	SVA-L 15 FPT ANG CAP	52	754	148B5265
20	¾	SVA-L 20 FPT ANG H-WHEEL	52	754	148B5364
20	¾	SVA-L 20 FPT ANG CAP	52	754	148B5365
25	1	SVA-L 25 FPT ANG H-WHEEL	52	754	148B5464
25	1	SVA-L 25 FPT ANG CAP	52	754	148B5465
32	1¼	SVA-L 32 FPT ANG H-WHEEL	52	754	148B5564
32	1¼	SVA-L 32 FPT ANG CAP	52	754	148B5565

## Shut-off valve, type SVA-S and SVA-L

**Table 60: SVA-L Straightway - FPT inside pipe thread, NPT (ANSI/ASME B 1.20.1)**

Size		Type	MWP		Code number
mm	in.		bar	psi	
15	½	SVA-L 15 FPT STR H-WHEEL	52	754	148B5274
15	½	SVA-L 15 FPT STR CAP	52	754	148B5275
20	¾	SVA-L 20 FPT STR H-WHEEL	52	754	148B5374
20	¾	SVA-L 20 FPT STR CAP	52	754	148B5375
25	1	SVA-L 25 FPT STR H-WHEEL	52	754	148B5474
25	1	SVA-L 25 FPT STR CAP	52	754	148B5475
32	1¼	SVA-L 32 FPT STR H-WHEEL	52	754	148B5574
32	1¼	SVA-L 32 FPT STR CAP	52	754	148B5575

**ANG** = Angleway  
**STR** = Straightway  
**CAP** = Cap  
**H-WHEEL** = Hand wheel

### Accessories

**Table 61: 6T Nipple Kit solution**

Code no.	Description
148B4245	ACCESSORY WELD.NIPPLE DN6 A + UNION NUT
148B4184	ACCESSORY WELD.NIPPLE DN6 D + UNION NUT

### Ordering SVA-S from the parts programme

**Example** (select from below two tables)

**Figure 32: SVA-S parts assembling**

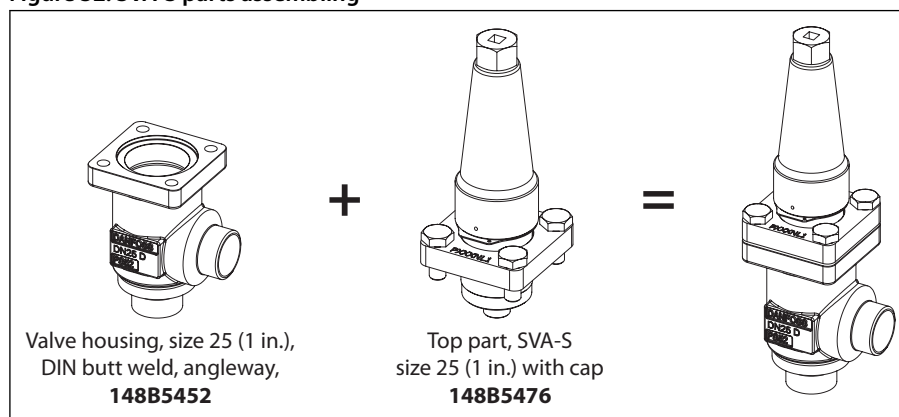

**Figure 33: DN 6-10 mm (¼ - ⅜ in.)**

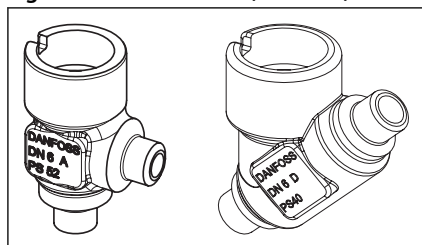

**Figure 34: DN 15-65 mm (½ - 2½ in.)**

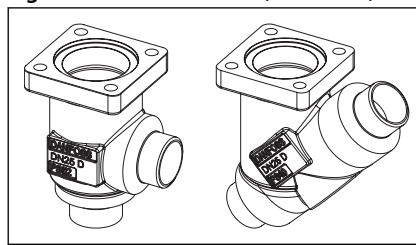

**Figure 35: DN 80-125 mm (3 - 5 in.)**

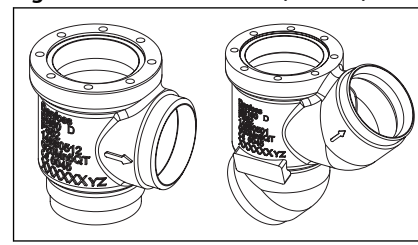

**Table 62: SVL valve housings w/different connections**

Sizes [DN]		Valve Housing SVL											
		DIN-Butt weld		ANSI-Butt weld		GOST-Butt-weld		SOC		FPT		T	
mm	in.	ANG	STR	ANG	STR	ANG	STR	ANG	STR	ANG	STR	ANG	
6	¼	148B5002	148B5003	148B5004	148B5005	-	-	-	-	-	-	-	148B5012
10	⅜	148B5122	148B5123	148B5124	148B5125	148B5134	148B5135	-	-	-	-	-	-
15	½	148B5252	148B5253	148B5254	148B5255	148B5391	148B5392	148B5256	148B5257	148B5258	148B5259	-	-
20	¾	148B5352	148B5353	148B5354	148B5355	148B5393	148B5394	148B5356	148B5357	148B5358	148B5359	-	-

## Shut-off valve, type SVA-S and SVA-L

Sizes [DN]		Valve Housing SVL										
		DIN-Butt weld		ANSI-Butt weld		GOST-Butt-weld		SOC		FPT		T
mm	in.	ANG	STR	ANG	STR	ANG	STR	ANG	STR	ANG	STR	ANG
25	1	148B5452	148B5453	148B5454	148B5455	148B5498	148B5499	148B5456	148B5457	148B5458	148B5459	-
32	1¼	148B5576	148B5577	148B5578	148B5579	148B5593	148B5594	148B5580	148B5581	148B5582	148B5583	-
40	1½	148B5652	148B5653	148B5654	148B5655	148B5681	148B5682	148B5656	148B5657	-	-	-
50	2	148B5741	148B5742	148B5743	148B5744	148B5759	148B5760	148B5745	148B5746	-	-	-
65	2½	148B5816	148B5817	148B5818	148B5819	148B5816	148B5817	-	-	-	-	-
80	3	148B5912	148B5913	148B5914	148B5915	148B5912	148B5913	-	-	-	-	-
100	4	148B6014	148B6015	148B6016	148B6017	148B6033	148B6034	-	-	-	-	-
125	5	148B6112	148B6113	148B6114	148B6115	148B6133	148B6134	-	-	-	-	-

**NOTE:**

Not all sizes available for SVA-L - see next following table

**Figure 36: SVA complete top parts**

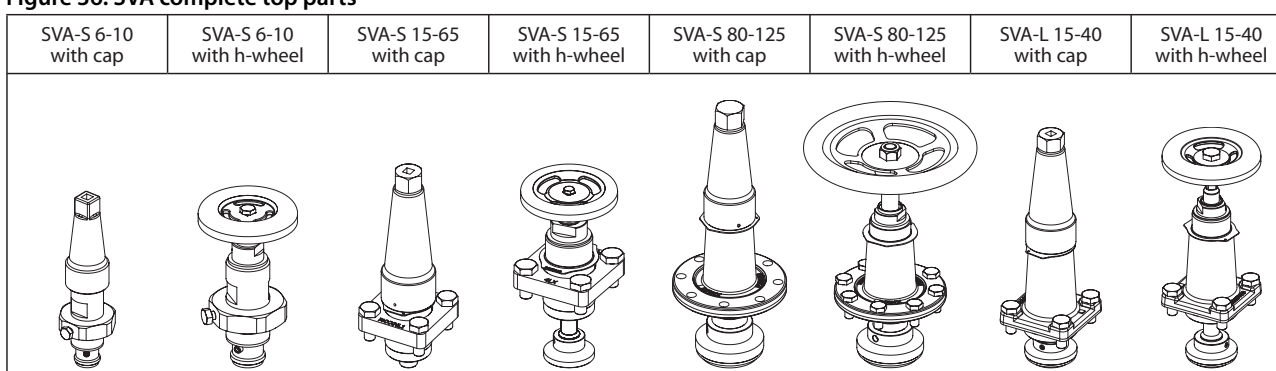

**Table 63: SVA complete top part including gaskets and bolts**

Sizes [DN]		Complete top part			
mm	in.	SVA-S CAP	SVA-S H-WHEEL	SVA-L CAP	SVA-L H-WHEEL
6	¼	148B5013	148B5014	-	-
10	⅜			-	-
15	½	148B5276	148B5277	148B5278	148B5279
20	¾				
25	1	148B5476	148B5477	148B5478	148B5479
32	1¼				
40	1½				
50	2	148B5728	148B5729	-	-
65	2½	148B5822	148B5823	-	-
80	3	148B5916	148B5917	-	-
100	4	148B6012	148B6018	-	-
125	5	148B6116	148B6117	-	-

## Certificates, declarations, and approvals

The list contains all certificates, declarations, and approvals for this product type. Individual code number may have some or all of these approvals, and certain local approvals may not appear on the list.

Some approvals may change over time. You can check the most current status at danfoss.com or contact your local Danfoss representative if you have any questions.

### Valid approvals

**Table 64: Pressure Equipment Directive (PED)**

	SVA valves are approved according to the European standard specified in the Pressure Equipment Directive and are CE marked.
---	---

For further details / restrictions - see Installation Instruction.

**Table 65: SVA**

Nominal bore	SVA		
	DN≤ 25 mm (1 in.)	DN32-80 mm (1¼ - 3 in.)	DN100 - 200 mm (4-8 in.)
Classified for	Fluid group I		
Category	Article 3, paragraph 3	II	III

**Table 66: Certificates and declarations**

File name	Document type	Document topic	Approval authority
03709-F0 BV	Marine - Safety Certificate	-	BV
TAP0000003 Rev. 1	Marine - Safety Certificate	-	DNV GL
033F0685.AK	EU Declaration	EMCD/PED	Danfoss
033F0691.AE	Manufacturers Declaration	RoHS	Danfoss
0045 202 1204 Z 00354 19 D 001(00)	Pressure - Safety Certificate	PED	TÜV
0045 202 1204 Z 00355 19 D 001(00)	Pressure - Safety Certificate	-	TÜV
033F0453.AD	Manufacturers Declaration	ATEX	Danfoss
19.10048.266	Marine - Safety Certificate	-	RMRS



## Online support

Danfoss offers a wide range of support along with our products, including digital product information, software, mobile apps, and expert guidance. See the possibilities below.

### The Danfoss Product Store



The Danfoss Product Store is your one-stop shop for everything product related—no matter where you are in the world or what area of the cooling industry you work in. Get quick access to essential information like product specs, code numbers, technical documentation, certifications, accessories, and more.

Start browsing at [store.danfoss.com](https://store.danfoss.com).

### Find technical documentation



Find the technical documentation you need to get your project up and running. Get direct access to our official collection of data sheets, certificates and declarations, manuals and guides, 3D models and drawings, case stories, brochures, and much more.

Start searching now at [www.danfoss.com/en/service-and-support/documentation](https://www.danfoss.com/en/service-and-support/documentation).

### Danfoss Learning



Danfoss Learning is a free online learning platform. It features courses and materials specifically designed to help engineers, installers, service technicians, and wholesalers better understand the products, applications, industry topics, and trends that will help you do your job better.

Create your Danfoss Learning account for free at [www.danfoss.com/en/service-and-support/learning](https://www.danfoss.com/en/service-and-support/learning).

### Get local information and support



Local Danfoss websites are the main sources for help and information about our company and products. Find product availability, get the latest regional news, or connect with a nearby expert—all in your own language.

Find your local Danfoss website here: [www.danfoss.com/en/choose-region](https://www.danfoss.com/en/choose-region).

### Spare Parts



Get access to the Danfoss spare parts and service kit catalog right from your smartphone. The app contains a wide range of components for air conditioning and refrigeration applications, such as valves, strainers, pressure switches, and sensors.

Download the Spare Parts app for free at [www.danfoss.com/en/service-and-support/downloads](https://www.danfoss.com/en/service-and-support/downloads).

### Coolselector®2 - find the best components for you HVAC/R system



Coolselector®2 makes it easy for engineers, consultants, and designers to find and order the best components for refrigeration and air conditioning systems. Run calculations based on your operating conditions and then choose the best setup for your system design.

Download Coolselector®2 for free at [coolselector.danfoss.com](https://coolselector.danfoss.com).

### Danfoss A/S

Climate Solutions • [danfoss.com](https://danfoss.com) • +45 7488 2222

Any information, including, but not limited to information on selection of product, its application or use, product design, weight, dimensions, capacity or any other technical data in product manuals, catalogues descriptions, advertisements, etc. and whether made available in writing, orally, electronically, online or via download, shall be considered informative, and is only binding if and to the extent, explicit reference is made in a quotation or order confirmation. Danfoss cannot accept any responsibility for possible errors in catalogues, brochures, videos and other material. Danfoss reserves the right to alter its products without notice. This also applies to products ordered but not delivered provided that such alterations can be made without changes to form, fit or function of the product.

All trademarks in this material are property of Danfoss A/S or Danfoss group companies. Danfoss and the Danfoss logo are trademarks of Danfoss A/S. All rights reserved.