

Instructions for installation and use

# Indirect, fully insulated district heating substation VXe Solo

District heating substation for indirect heating and connection pipes for domestic hot water.

**VXe  
Solo**

Fully insulated  
for very low heat  
losses.

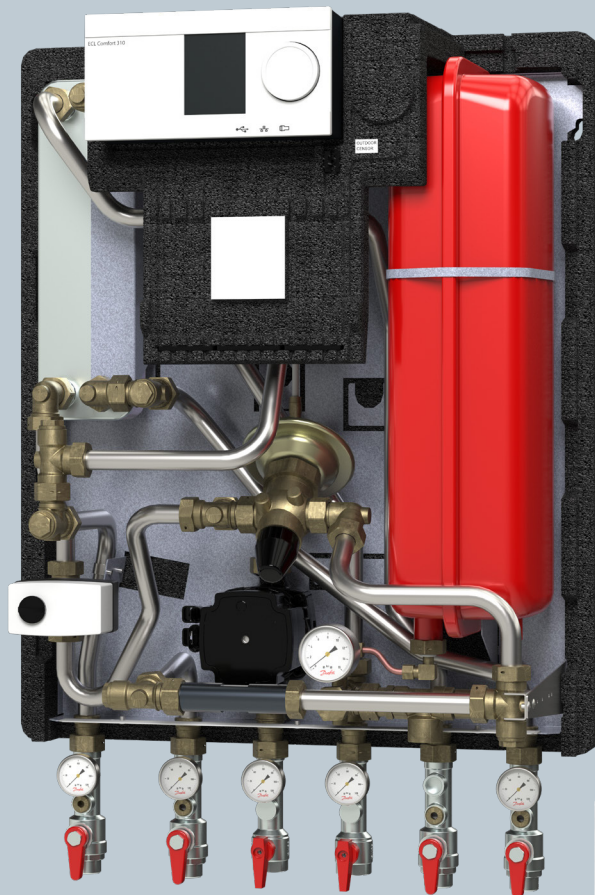

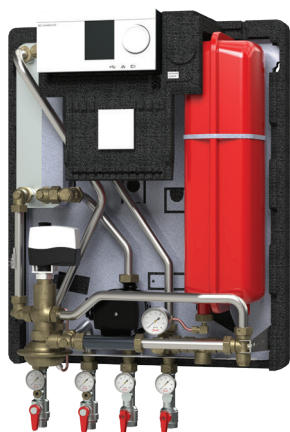

VXe Solo H  
ECL 310/A230

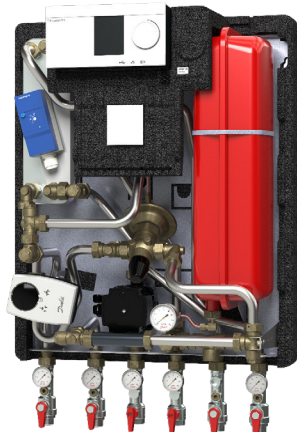

VXe Solo HWP  
ECL 310/A337



VXe Solo HWS  
ECL 310/A237



VXe Solo H OP  
ECL 310

## 1.0 Content

2.0	Installation instructions, safety and handling.....	3
3.0	Getting started - Quick guide for easy start-up.....	5
4.0	Main components / Connections.....	7
5.0	Diagram, Dimensional sketch, Example.....	10
6.0	General, Mounting of heat meter and safety valves.....	15
7.0	Filling the system with water.....	16
8.0	Electrical connections.....	17
9.0	Adjustment and commissioning.....	18
10.0	Heating circuit, Danfoss ECL 310 automatics.....	19
11.0	Control of heating circuit.....	20
12.0	Heating circuit, pump.....	22
13.0	Domestic hot water, Cylinder circuit.....	24
14.0	Maintenance / Supervision.....	27
15.0	Troubleshooting.....	29
16.0	EU Declaration of conformity.....	32
17.0	Commissioning Certificate.....	34
18.0	Guidelines for water quality in Danfoss brazed heat exchangers.....	35

## 2. INSTALLATION INSTRUCTIONS, SAFETY AND HANDLING

### Instructions

Please read these instructions carefully before installing and commissioning this substation. The manufacturer accepts no liability for loss or damage resulting from failure to comply with these instructions for use. Read and follow these instructions carefully to prevent the risk of physical injury and/or damage to property. Exceeding the recommended operating parameters considerably increases the risk of personal injury and/or damage to property. Installation, commissioning and maintenance must be carried out by qualified and authorized personnel in compliance with the local safety regulations.

Once the station has been installed and is operating, there is *normally* no need to alter the settings or other functions. The district heating substation is very reliable and easy to operate.

### Energy source

The substation is primarily designed for connection to district heating. Alternative energy sources can be used if the operating conditions are equivalent to district heating at all times.

### Application

The substation is designed only to operate with water and other heating media may not be used.

The substation is to be connected to the household piping in a frost-free room, where the temperature does not exceed 50 °C and the relative humidity is not higher than 80%. The substation must not be covered, bricked in or otherwise cut off from access.

### Choice of materials

Only use materials, that comply with local regulations.

### Corrosion protection

***The risk of equipment corrosion increases considerably if recommended permissible chloride compounds are exceeded.***

All pipes are made of min. AISI 304 (heating) and min. AISI 316 (domestic water) stainless steel as well as brass. Components for domestic water, however, primarily in dezincification-resistant brass. Heat exchangers are made of stainless steel and are copper-soldered or steel-soldered. Surfaces in contact with water can be subject to two problems, limescale formation and corrosion.

The nature of the water will be of great importance in this context, where the pH value, chlorides, gases, etc., have a decisive effect on how much lime is deposited and how aggressive the water is.

The temperature also has a great influence in this context. For example the corrosion rate increases by a factor of 2 to 3 for every 10° C temperature rise.

With knowledge of the chemical water composition and operating conditions of a heating system, the risk of scaling and corrosion can be assessed. Based on that, recommendations can be made to avoid scaling and/or corrosion problems in the components.

*See item 18, page 35 for more detailed Guidelines for Water Quality in Danfoss brazed heat exchangers and recommended Chloride concentration to avoid Stress Corrosion Cracking.*

### Safety valve(s)

**Installation of safety valve(s) must always be in compliance with local regulations.**

### Noise level.

≤ 55 dB.

### Storage

Before installation, the units must be stored in a dry, heated (i.e. frost-free) room.

(Relative humidity max. 80% and storage temperature 5-70 °C).

The units must not be stacked higher than the limit at the factory (max. 8 layers) Units supplied in cardboard packaging must be lifted using the handles incorporated in the packaging. Units must be placed on pallets for transport/moving across large distances.

As far as possible, do not lift the substation by the pipes. Lifting by the pipes may cause leaks. REMEMBER to retighten.



### Connection

It must be possible to cut off all energy sources to the unit - including electrical connections - at all times. The unit must be connected to an electrical equalizer connection.

### Warning! Hot surfaces

Parts of the substation may be very hot and can cause burn injuries. Be very careful when you are in the immediate vicinity of the substation.

### Warning of high pressure and high temperature

The maximum supply temperature in the district heating network can be up to 120°C and the operating pressure can be up to 16 bar. This may result in a risk of scalding from touching the substation and from outflow of the medium (water/steam). Exceeding the substation design data and operating parameters for pressure and temperature carries an appreciable risk of personal injury and/or damage to property.

### Emergencies

In the event of fire, leaks or other hazards, immediately shut off all sources of energy to the substation, if possible and call for appropriate assistance.

If the domestic hot water is discoloured or malodorous, shut off all ball valves on the substation, notify all users and call for professional assistance immediately.

### Warning of damage during transport

On reception of the substation, and before installing it, check for any evidence of damage during transport.

The substation must be handled and moved with the greatest care and attention.

### IMPORTANT - Tightening of connections

Before adding water to the system, ALL pipe connections MUST be retightened, as vibrations during transport may have caused leaks. Once the substation has been filled and the system has been put into operation, ALL pipe connections MUST be tightened once more.

**(Do not overtighten! - See page 15, Test and Connections)**



### Handling

We recommend that you wear suitable safety footwear while handling and installing the substation.

**NOTE:** Interventions/rework on our components results in loss of warranty.

## 2. INSTALLATION INSTRUCTIONS, SAFETY AND HANDLING

### Reach

All products of the Akva Lux II Triiiple series comply with the provisions of the REACH regulation.

We are therefore obliged to inform our customers about the presence of substances according to the SVHC candidate list, if they are present.

We hereby inform you: This product contains brass parts containing lead (CAS 7439-92-1) in a concentration above 1% (w/w).

### Potential equalization / grounding

Equipotential bonding is understood as all measures for eliminating electrical potential differences (contact voltages), which can occur between eg two pipelines. Equipotential bonding is an important measure for protection against electric shock. Equipotential bonding reduces corrosion in the heat exchanger, instantaneous water heaters, district heating stations and plumbing installations. Equipotential bonding should be in accordance with the provisions 60364-4-41:2007 and IEC 60364-5-54:2011. Binding point is marked with a grounding symbol on the bottom right corner of the mounting plate and there is a hole in the mounting plate and a label with grounding symbol.

### Disposal

Dispose of the packaging in accordance with the local regulations for disposal of used packaging materials.

The substation is made of materials that cannot be disposed of together with household waste.

Close all energy sources and disconnect all connection pipes. Disconnect and dismantle the product for disposal in accordance with the applicable local regulations for the disposal of the individual components.

### 3. GETTING STARTED - QUICK GUIDE FOR EASY START-UP

#### Mounting

Connect the substation to the household piping in accordance with the labelling at the bottom and/or in accordance with the instructions in this manual.

*GETTING STARTED is a quick guide and some details in connection with installation and commissioning may require additional information, which can be found elsewhere in this instruction manual.*

#### GETTING STARTED VXe Solo

1. Mount the substation on a solid wall using two sturdy bolts (max. 8 mm), screws, expansion bolts or similar.
2. Tighten all pipe connections, as they may have loosened during transport and handling.
3. Mount the district heating meter (see page 15).
4. On systems that feature a safety valve, establish a drain connection in compliance with the applicable legislation.
5. Fill the heat exchanger / the system with water according to the instructions on page 16.
6. Open the ball valve for the HE supply and return flow and heat up the system.
7. Check the substation and the household piping thoroughly for leaks.
8. Pressure test the entire system for leaks in accordance with the applicable regulations.
9. Connect pump and automatic components, if any, to the electricity supply, but do not switch on the power.
10. Heat the system and vent the radiator circuit/heating side thoroughly on the radiators and the air valve, if any.
11. Connection  
Now switch on the pump and automatic components, if any.
12. Finish by adjusting the substation in accordance with the instruction manuals and remember to fill out the Commissioning Certificate page 34.

#### Note!

**Heating and cooling the substation may cause leaks. Therefore it may be necessary to retighten the connections in the period after commissioning.**

#### Note!

**Never lift the station by its front insulation cover!**

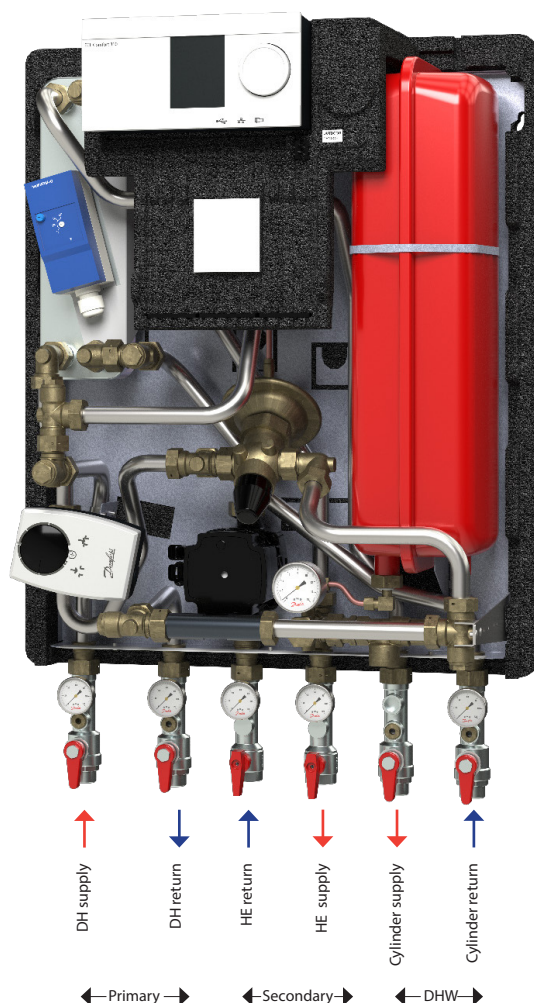

### 3. GETTING STARTED - QUICK GUIDE FOR EASY START-UP

**Start-up:** See page 5 "Getting started"

**Diagram examples:** See page 11 - 14

**Main components.** See page 7 - 10

**Mounting / Mounting of heat meter:** See page 15

**Safety valves:** See page 15

**Electrical connection:** See page 17

Outdoor sensor: Connect to terminal block U

**Filling the system with water:** See page 16

**Commissioning:** See page 18-26

**Reading of meter:**

Consumption and actual DH temperatures can be read on the meter display, placed under the ECL controller.

**Temperatures:**

To be read on thermometers (Pos. no. 13)

**Pressure:**

To be read on manometer (Pos. no. 15)

**Connections:**

Pos. no's 7A (DH), 7B (HE), 7C (DHW)

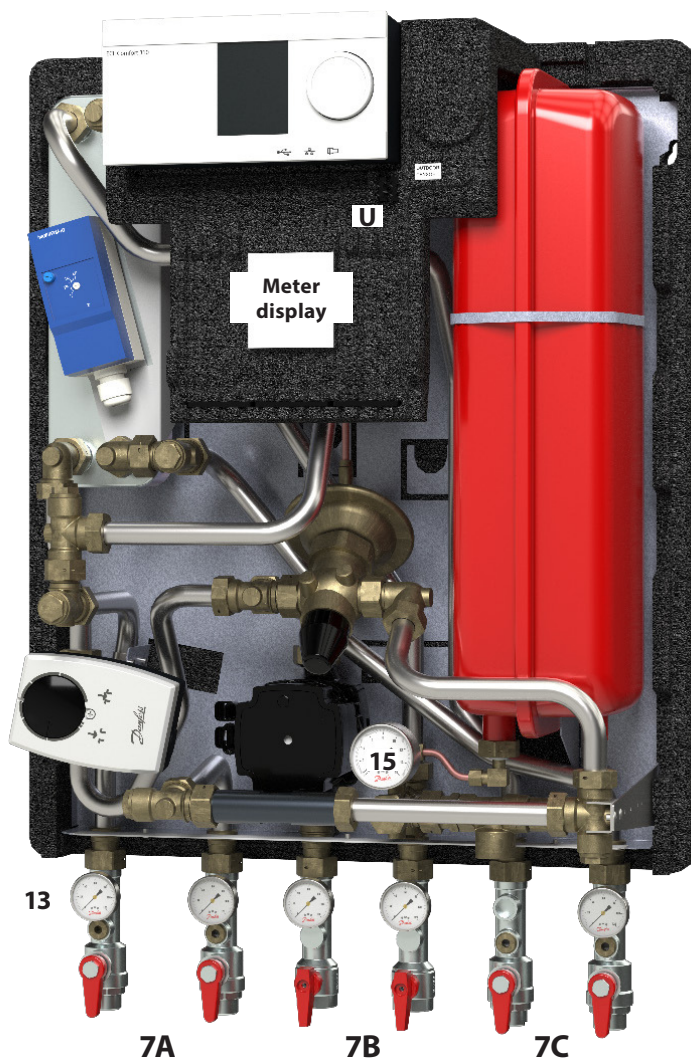

#### 4. MAIN COMPONENTS / CONNECTION- VXE H SOLO 310/A237

- 1 Plate heat exchanger HE, with insulation
- 5 Strainer
- 7 Ball valve
- 8 Circulation pump HE
- 11 Safety valve HE
- 13 Thermometer
- 14 Pocket for pressure gauge
- 15 Manometer
- 16 Expansion vessel
- 23 Sensor pocket for heat meter
- 24 Fitting piece for heat meter 3/4" x 110 mm
- 25 Controller Danfoss ECL310/A230
- 29 Danfoss actuator AMV
- 30 Flow controller with integrated control valve AVQM

Option:

- 54 Safety thermostat, Jumo AT

**Accessories available as extra equipment (mounting on site)**

KFE tap - Code No. 145H3717  
For filling and draining 1/4".

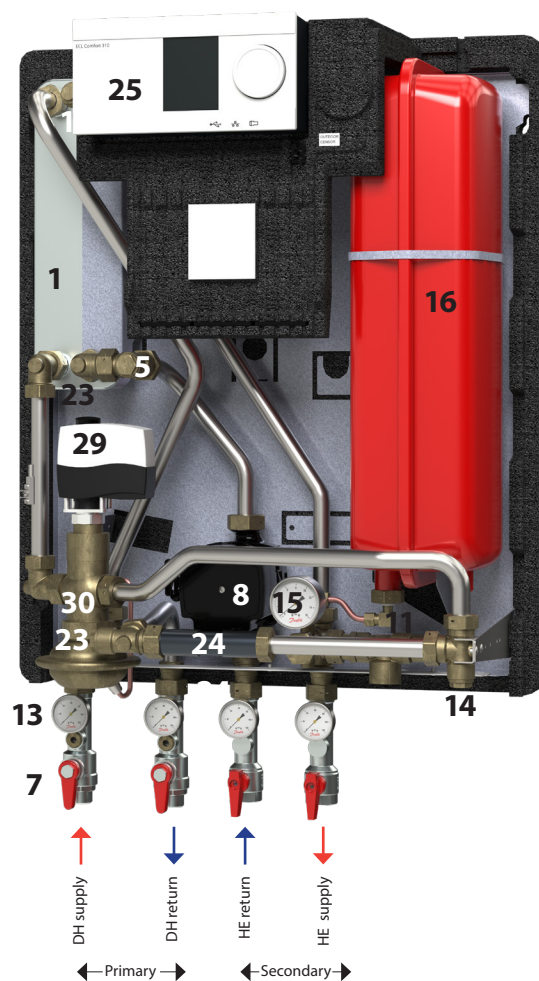

#### 4. MAIN COMPONENTS / CONNECTION- VXE SOLO HWP ECL 310/A337

- 1 Plate heat exchanger HE, with insulation
- 4 Differential pressure controller and flow limiter AVPB-F
- 5 Strainer
- 7A Ball valve ¾ ET/ET 120 mm for thermometer/manometer
- 7B Ball valve ¾ IT/ET 120 mm for thermometer
- 8 Circulation pump, HE
- 11 Safety valve HE, 3 bar ½"
- 13 Thermometer
- 14 Pocket for pressure gauge
- 15 Manometer
- 16 Expansion vessel 12 l
- 23 Sensor pocket for heat meter
- 24 Fitting piece for heat meter ¾" x 110 mm
- 25 Controller Danfoss ECL310/A337
- 29 Danfoss actuator AMV
- 30 Two-way valve VS2

Option:

- 54 Safety thermostat, Jumo AT

#### Accessories available as extra equipment (mounting on site)

Thermostatic valve RAVK/VMA for DHW  
Code No. 144B2021

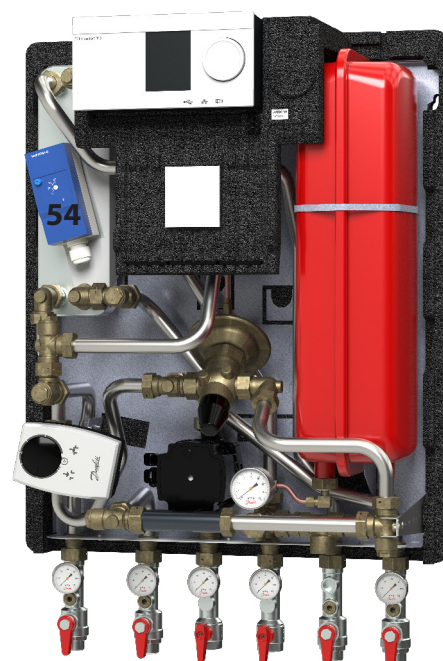
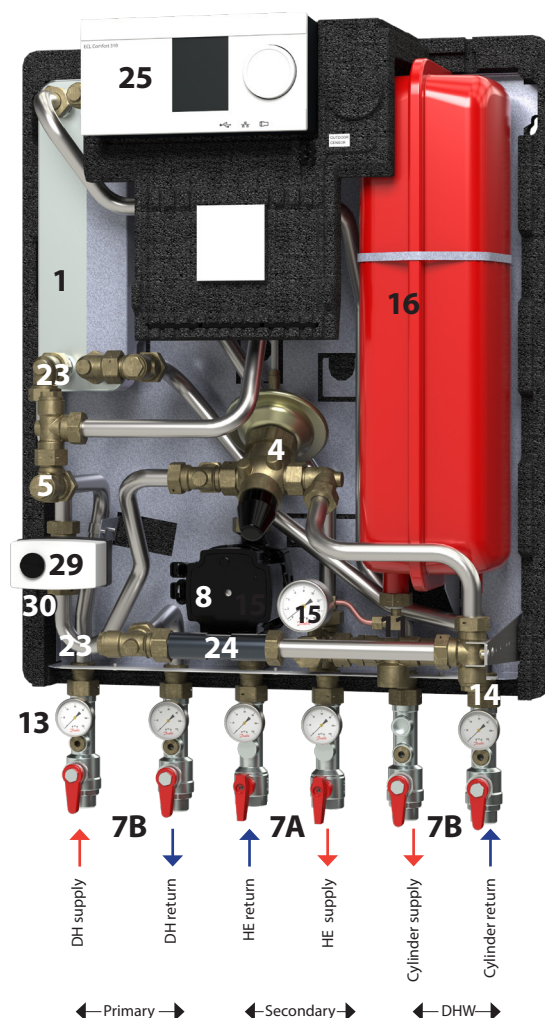



### 4. MAIN COMPONENTS / CONNECTION- VXE SOLO HWS ECL 310/A337

- 1 Plate heat exchanger HE, with insulation
- 5 Strainer
- 6 Non-return valve
- 7 Ball valve
- 8A Circulation pump, HE
- 8B Circulation pump, cylinder
- 11 Safety valve HE, 3 bar 1/2"
- 13 Thermometer
- 14 Pocket for pressure gauge
- 15 Manometer
- 16 Expansion vessel 12 l
- 23 Sensor pocket for heat meter
- 24 Fitting piece for heat meter 3/4" x 110 mm
- 25 Controller Danfoss ECL310/A337
- 29 Danfoss actuator AMV
- 30 Danfoss flow controller with integrated control valve AVQM

Option:

- 54 Safety thermostat, Jumo AT

**Accessories available as extra equipment (mounting on site)**

KFE tap - Code No. 145H3717  
For filling and draining 1/4"

Thermostatic valve RAVK/VMA for DHW  
Code No. 144B2021

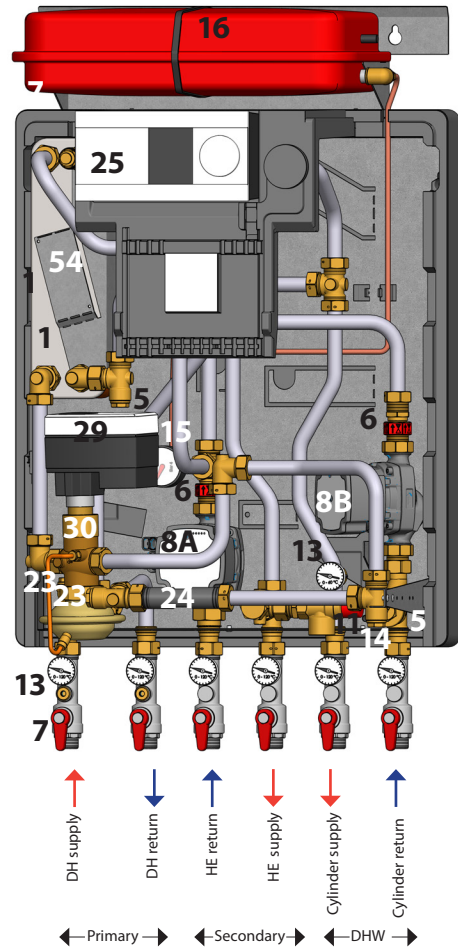

**PLEASE NOTE!**

*As an option VXe Solo HWS can be supplied with Danfoss flow controller with integrated control valve AHQM instead of AVQM.*

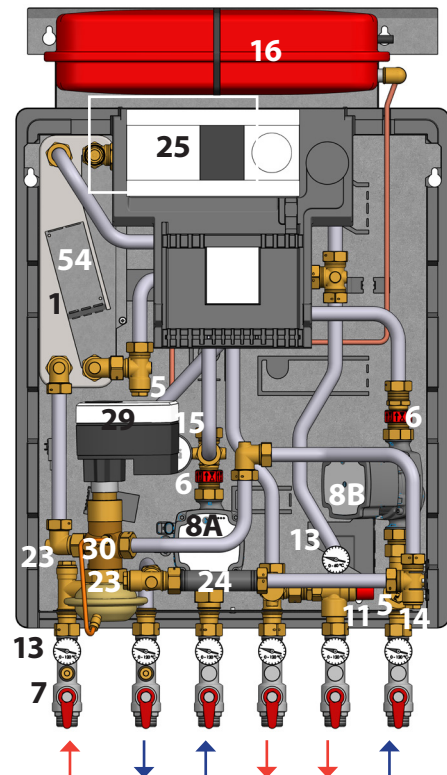

#### 4. MAIN COMPONENTS / CONNECTION - VXE H OP ECL 310

- 1 Plate heat exchanger HE
- 5 Strainer
- 7 Ball valve
- 11 Safety valve HE
- 13 Thermometer
- 14 Pocket for pressure gauge
- 15 Manometer
- 16 Connection for expansion vessel
- 23 Sensor pocket for heat meter
- 24 Fitting piece for heat meter 3/4" x 110 mm
- 25 Controller Danfoss ECL310/A230
- 26 Outdoor sensor, ESMT
- 27 Sensor, ESMC
- 29 Danfoss actuator AMV
- 30 Flow controller with integrated control valve AVQM

**Accessories available as extra equipment (mounting on site)**

KFE tap - Code No. 145H3717  
 For filling and draining 1/4".

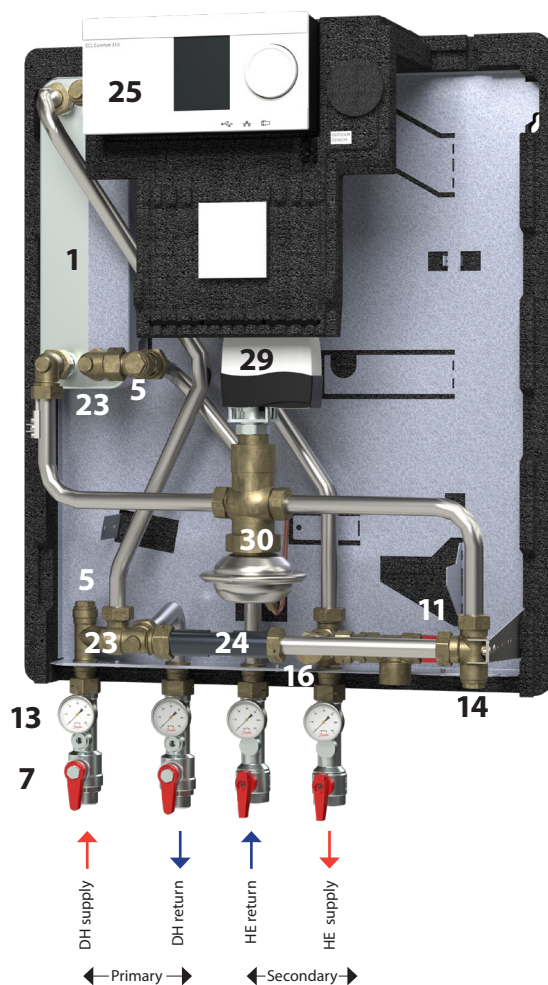

VXe Solo H OP	Code No.
Type 1, Cover	145F0620
Type 2, Cover	145F4438
Type 2, Cover, STW*	145F4454

\*Safety function = AMV13 / Jumo Safety Thermostat

5. DIAGRAM & DIMENSIONAL SKETCH, EXAMPLE - VXE SOLO H ECL310/A230

- 1 Plate heat exchanger HE
  - 5 Strainer
  - 7 Ball valve
  - 8 Circulation pump HE
  - 11 Safety valve HE
  - 13 Thermometer
  - 14 Pocket for pressure gauge
  - 15 Manometer
  - 16 Expansion vessel
  - 23 Sensor pocket for heat meter
  - 24 Fitting piece for heat meter 3/4" x 110 mm
  - 25 Controller Danfoss ECL310/A230
  - 26 Outdoor sensor, ESMT
  - 27 Sensor, ESMC
  - 29 Actuator AMV
  - 30 Flow controller with integrated control valve AVQM
- Option:  
Safety thermostat, Jumo AT

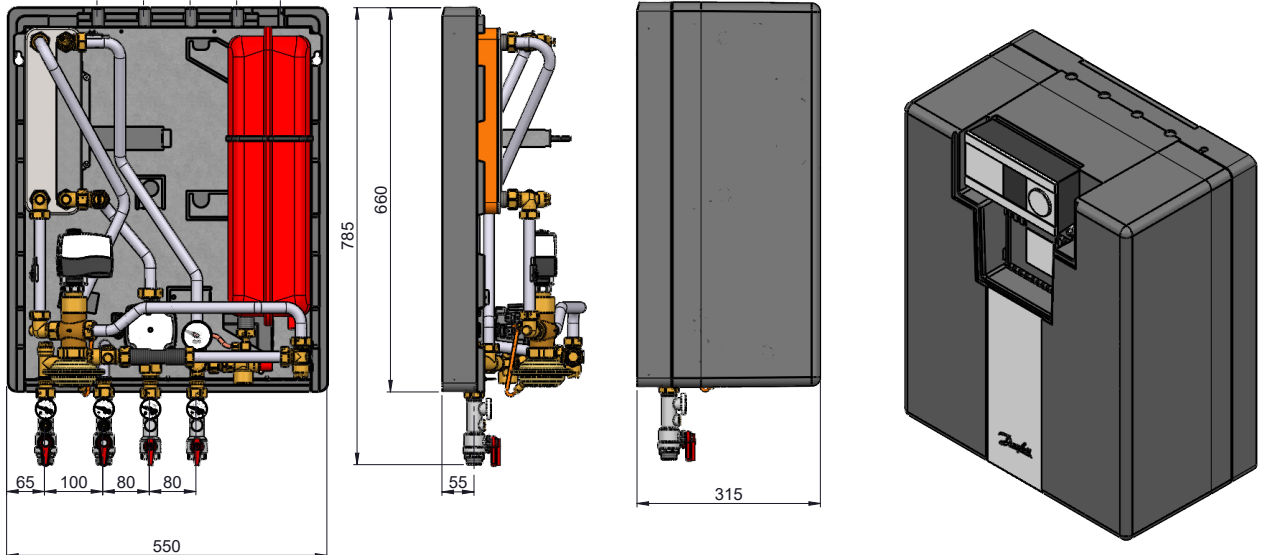
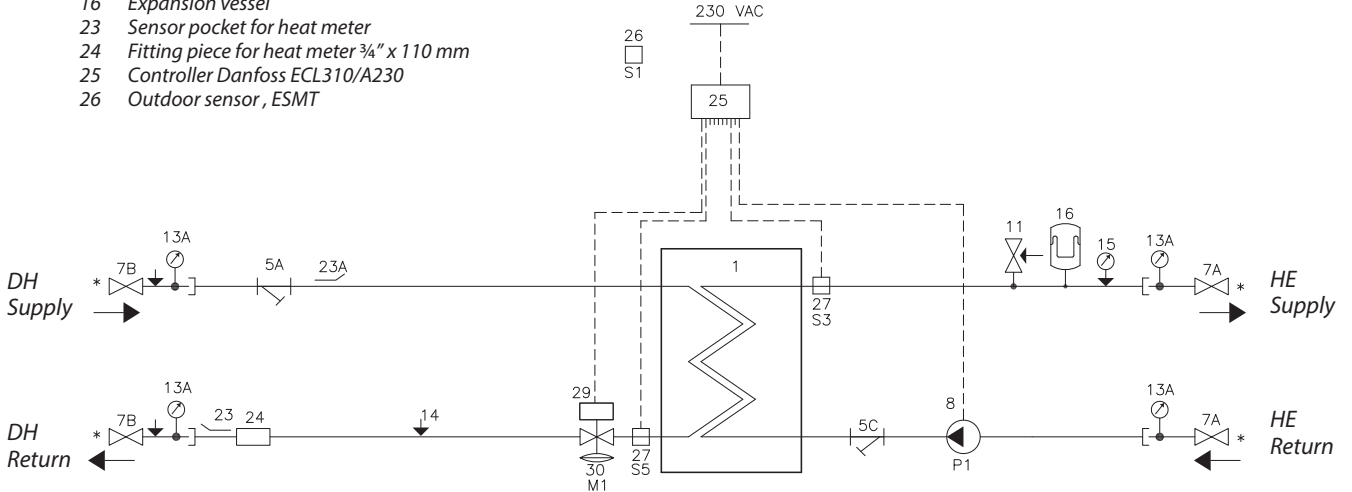

**Connections:**

- 1. District heating (DH) supply
- 2. District heating (DH) return
- 3. Heating (HE) return
- 4. Heating (HE) supply

General tolerance accuracy: measurements without tolerance:		Projection	Scale	Size	Material
ISO 2768 - mK			1:6	A3	
Weight	58.006 kg			Danfoss Standard	
Replace				Designation	
Design	17-09-2020 JJ			VXe Solo	
Approval				Danfoss Redan A/S	
Confidential: Property of Danfoss Redan A/S, Nordborg, Denmark. Not to be handed over to, copied or used by third party. Two- or three-dimensional reproduction of contents to be authorized by Danfoss Redan A/S.					No. 145F4440
					Rev.

5. DIAGRAM & DIMENSIONAL SKETCH, EXAMPLE - VXE SOLO HWP ECL 310/A337

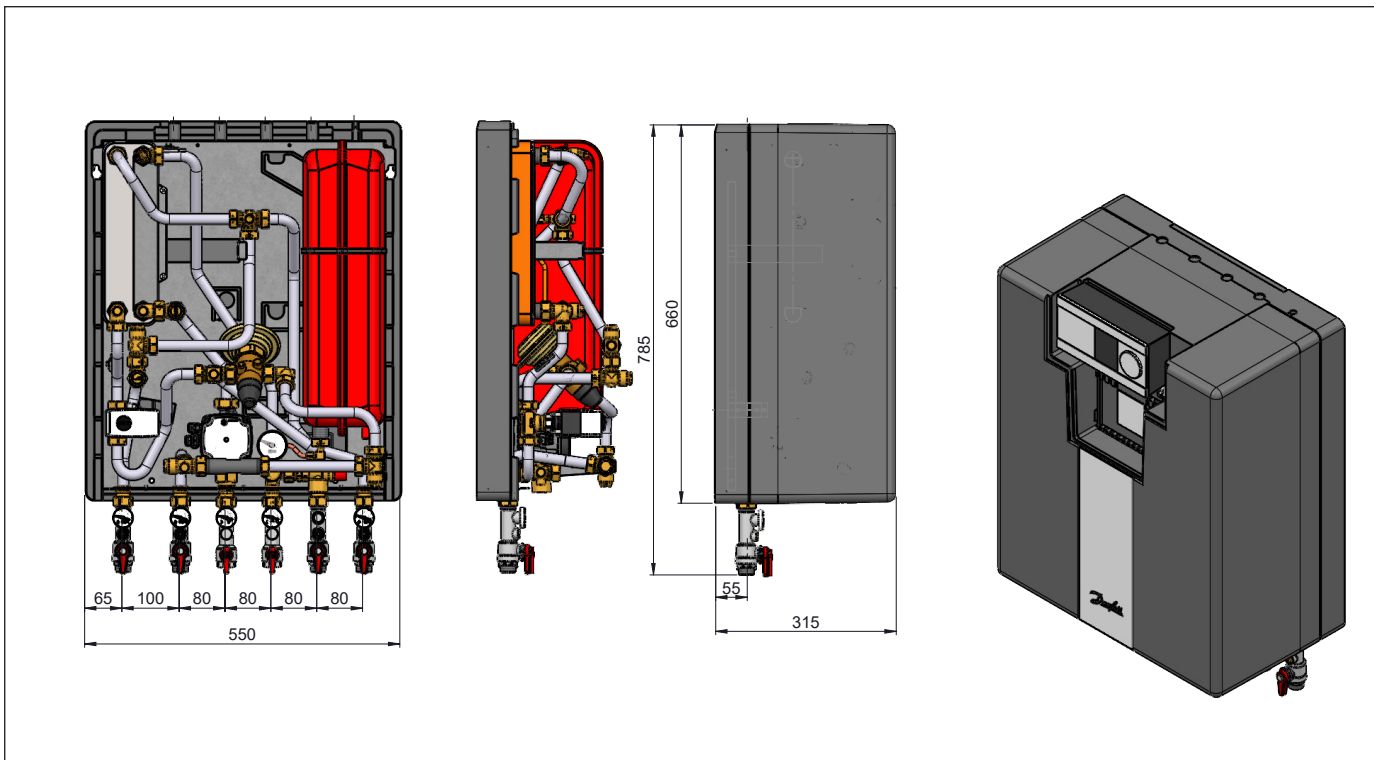
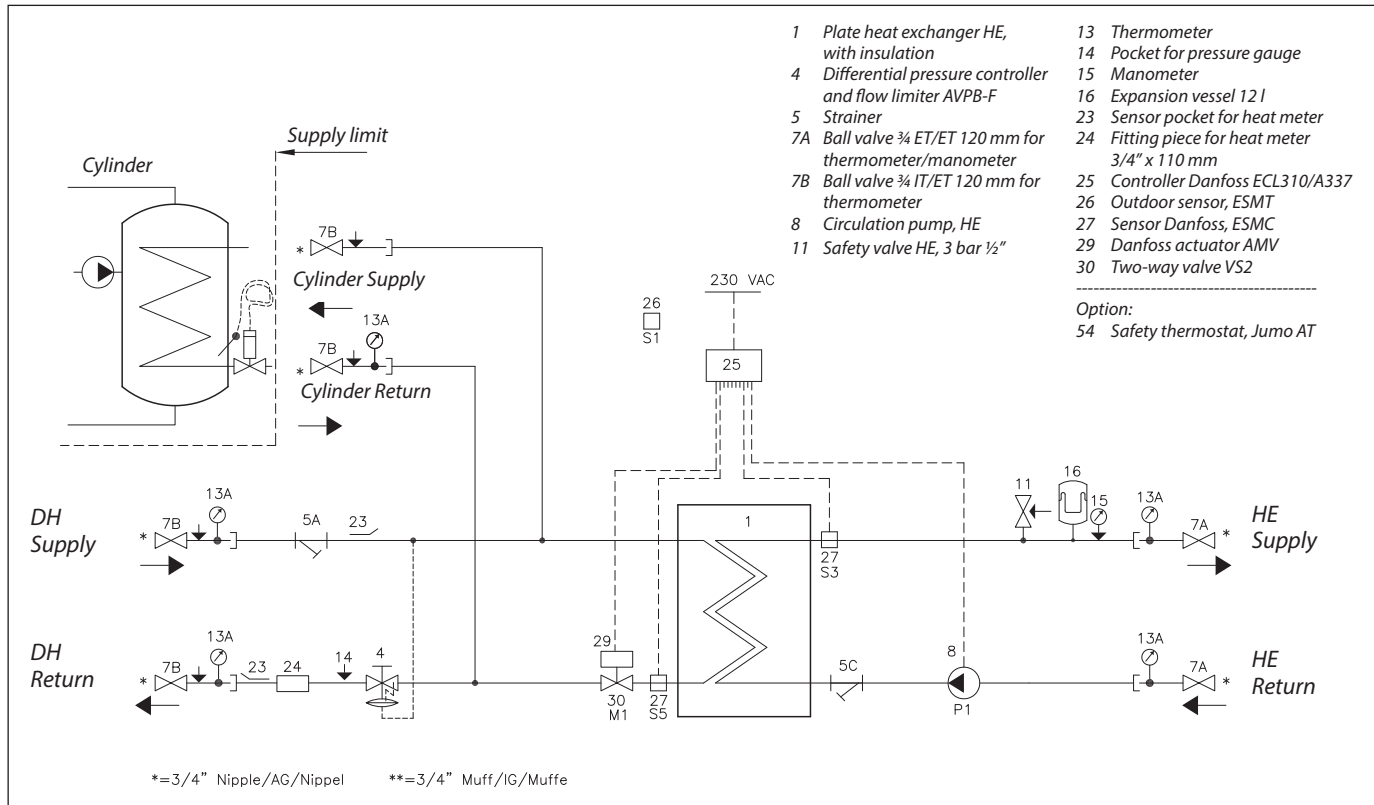

**Connections:**

1. District heating (DH) supply
2. District heating (DH) return
3. Heating (HE) return
4. Heating (HE) supply
5. Cylinder supply
6. Cylinder return

General tolerance accuracy, measurements without tolerance		Projection	Scale	Size	Material	
ISO 2768 - mK			1:6	A3		
Weight	61.068 kg				Danfoss Standard	
Replace					Designation	VXe Solo
Design	02-11-2016 JJ					
Approval						
Danfoss Redan A/S					No. 145F4445	
<small>Confidential: Property of Danfoss Redan A/S, Nordborg, Denmark. Not to be handed over to, copied or used by third party. Two or three dimensional reproduction of contents to be authorized by Danfoss Redan A/S.</small>					Rev.	
					Sheet 1/1	

### 5. DIAGRAM & DIMENSIONAL SKETCH, EXAMPLE - VXE SOLO HWS 310/A337

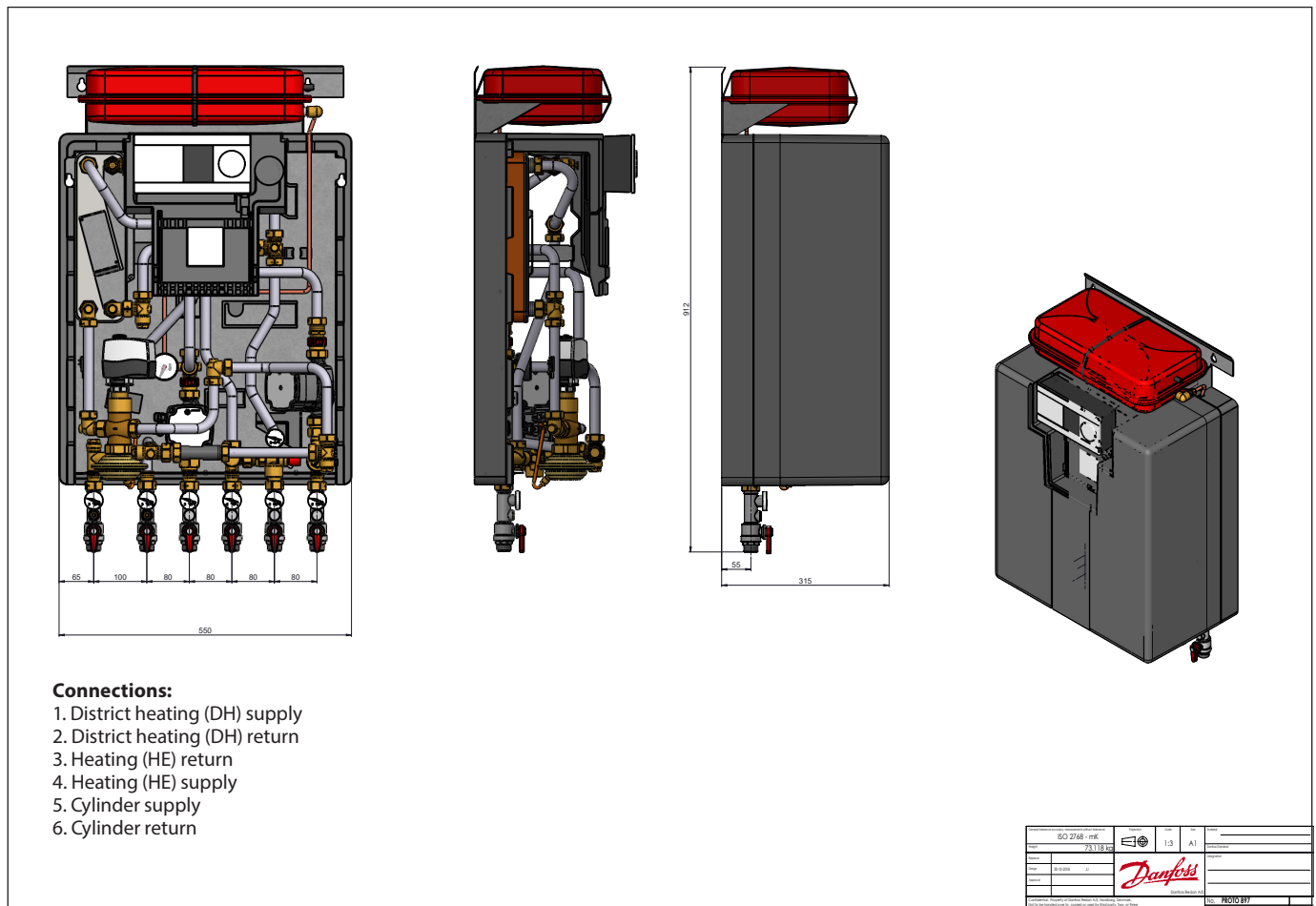
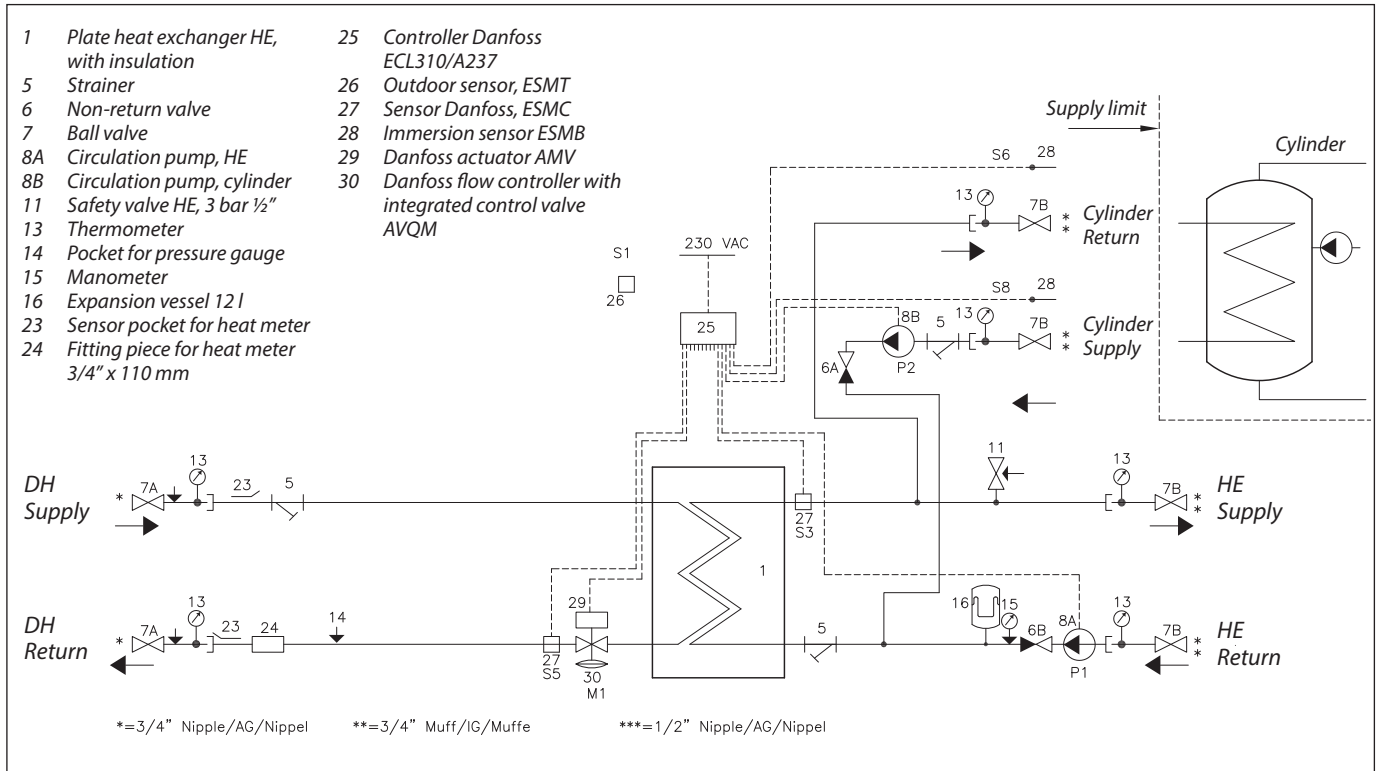

5. DIAGRAM & DIMENSIONAL SKETCH, EXAMPLE - VXE SOLO H OP ECL 310

- 1 Plate heat exchanger HE
- 5 Strainer
- 7 Ball valve
- 11 Safety valve HE
- 13 Thermometer
- 14 Pocket for pressure gauge
- 15 Manometer
- 16 Connection for expansion vessel
- 23 Sensor pocket for heat meter
- 24 Fitting piece for heat meter 3/4" x 110 mm
- 25 Controller Danfoss ECL310/A230
- 26 Outdoor sensor, ESMT
- 27 Sensor, ESMC
- 29 Danfoss actuator AMV
- 30 Flow controller with integrated control valve AVQM

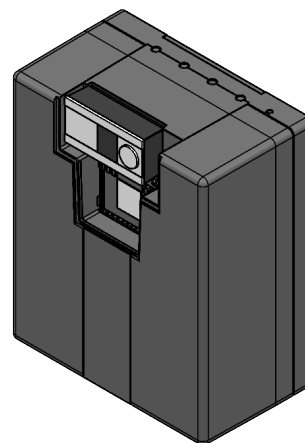
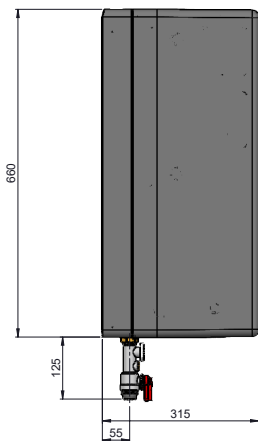
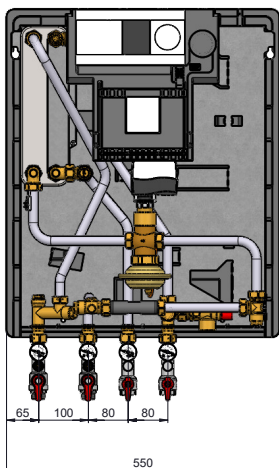
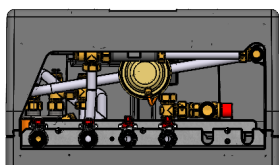
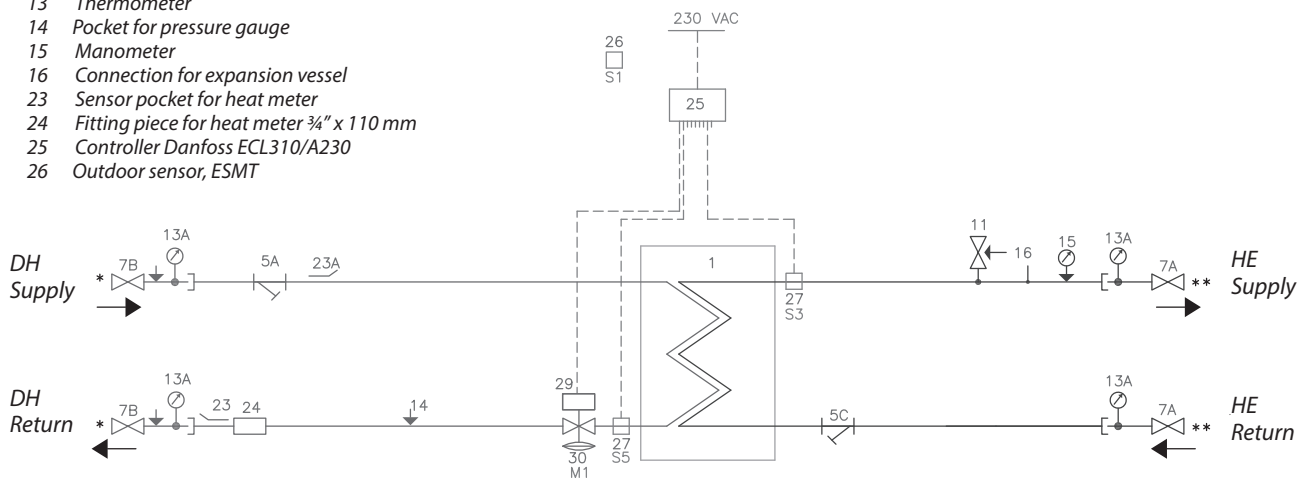

- Anschlüsse:**
1. Fernwärme (FW) Vorlauf
  2. Fernwärme (FW) Rücklauf
  3. Heizung (HE) Rücklauf
  4. Heizung (HE) Vorlauf

General technical data (see also the technical manual)		Proportion	Scale	Size	Material
ISO 2768 - mK			1:5	A2	
Weight	64,398 kg				
Release		 Danfoss Redan A/S			
Design	07.12.2016				
Approved					
Confidential. Property of Danfoss Redan A/S, Nordborg, Denmark. Not to be reproduced or to be copied or used by third parties. Any other dimensional reproduction of contents to be authorized by Danfoss Redan A/S.					No. 145F4439
					Rev.

## 6. GENERAL, MOUNTING OF HEAT METER AND SAFETY VALVES

### General

The installation, connection and maintenance of the substation must be performed by qualified and authorised personnel. Installation must always be performed in accordance with the applicable legislation and in compliance with these instructions.

The substation must be installed so that it is freely accessible and can be maintained without unnecessary disruption. Lift the substation by its mounting plate/rear section and secure it to a solid wall using 4 sturdy bolts (max. 8 mm), screws or expansion bolts positioned in the four keyholes.

Before commissioning, rinse all the pipes in the household piping system thoroughly to remove any impurities, and check and clean the dirt strainers in the substation.

Connect the substation to the household piping in accordance with the labelling at the bottom and/or in accordance with the instructions in this manual.

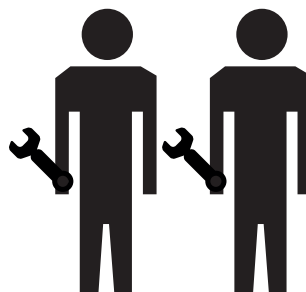

### For fully insulated systems

The insulation front panel on the VXe Solo substations can be removed without using tools. Take hold of the air duct in the top and bottom of the front insulation section and pull carefully forward until the front insulation section releases from the rear section. Then pull gently until the front section is free from the components.

### Test and connections

Before filling the system with water, retighten all the pipe connections because vibrations and shocks during transport and handling may have caused leaks. Once the system has been filled with water, tighten all the pipe connections once more before performing pressure test for leaks. After heating of the system, check all the connections and retighten if necessary.

Please note that the connections may feature EPDM rubber gaskets! Therefore, it is important that you **DO NOT OVERTIGHTEN** the union nuts. Overtightening may result in leaks. Leaks caused by overtightening or failure to retighten connections are not covered by the warranty.

### Heat meter, fitting pieces.

The substation is equipped with fitting pieces for heat meter on the district heating return line. (Measurement: 3/4" x 110 mm).

### Fitting of heat meters

- Close the four ball valves on the district heating and the heating sides.
- Loosen the union nuts at both ends of the fitting piece (A + B) and remove it.
- Fit the heat meter, - remember to insert gaskets.
- Mount sensor, - remember to insert gaskets.
- Mount temperature sensors in sensorpockets (according to heat meter instructions).
- After mounting of heat meter remember to check and tighten all pipe connections before commissioning the substation.

### Meter display (reading unit)

The meter reading unit is placed on the console together with the ECL regulator, as shown in the photo to the right, so that reading of the meter can be done without removing the insulation cover.

### Safety valve(s)

Always lead the blow-off pipe from the safety valve to a drain in accordance with applicable legislation.

The insulation cover is prepared for this and blow-off pipe from the safety valves are led through the slit in the insulating cover as shown in the photo to the right.

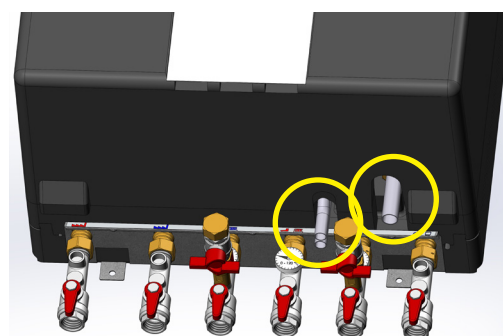
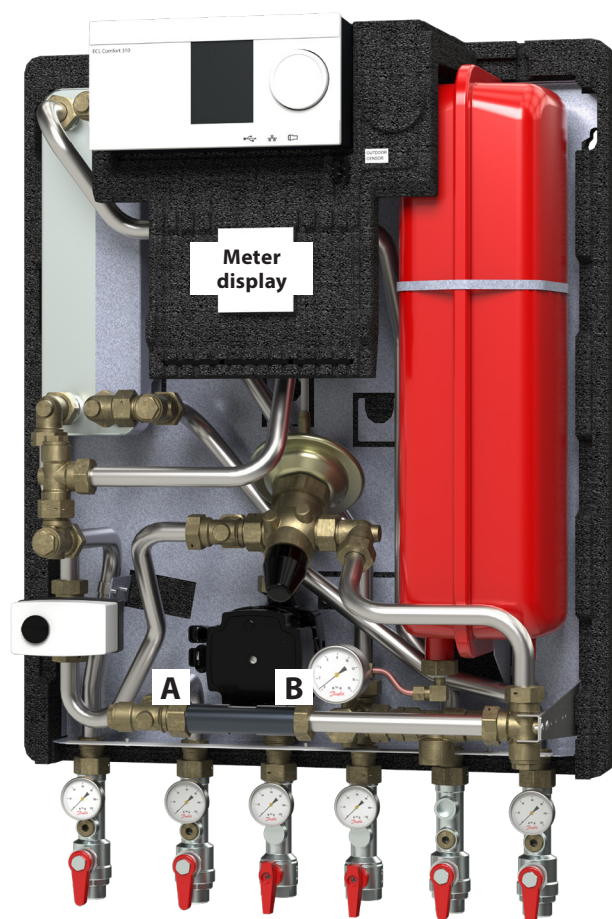

## 7. FILLING THE SYSTEM WITH WATER

### Test and connections

Before filling the system with water, retighten all the pipe connections because vibrations and shocks during transport and handling may have caused leaks. Once the system has been filled with water, tighten all the pipe connections once more before performing pressure test for leaks. After heating of the system, check all the connections and retighten if necessary.

Please note that the connections feature EPDM rubber gaskets! Therefore, it is important that you **DO NOT OVERTIGHTEN** the union nuts. Over-tightening may result in leaks. Leaks caused by over-tightening or failure to retighten connections are not covered by the warranty.

### Filling, start-up

Before filling the system with water, retighten all the pipe connections. Once the system has been filled with water, tighten all the pipe connections once more before performing pressure test for leaks. Before filling the system with water and starting-up, check if:

- pipes are connected according to the circuit diagram,
- expansion vessel is connected,
- heat meter is mounted,
- shut-off valves are closed,
- threaded and flanged connections are tightened,
- recirculation, if any, has been established.

### Filling the heat exchanger / the system with water:

- The pump must be switched off when filling the system with water.
- Open the ball valves for the HE supply and return flow and fill the system with water and at the same time venting the system.
- Fill the heat exchanger / the system with water until the manometer shows a working pressure, which corresponds to the system height + approx. 5 m (approx. 1.2 - 1.5 bar).
- Finally open the remaining ball valves and heat up the system.
- After filling and heat-up of the system it should be vented by means of the air vents on the substation, if any and on the radiators.
- Then switch on the pump.

**\* Note:** There is no filling valve inside the station. For refilling use a refill hose, customary for heating systems. **Filling of water to the heating system must be done outside the substation, typically by connection to a cold water supply in the household installation.**

### NOTE:

**Accessories available as extra equipment (mounting on site)**

KFE tap - code No. 145H3717

For filling and draining 1/4"

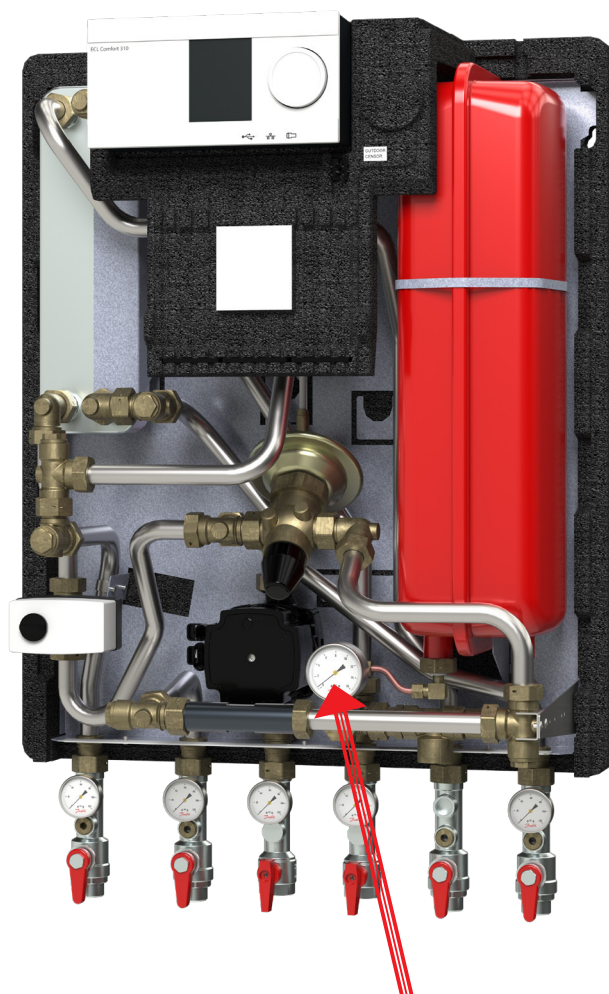

Manometer





## 8. ELECTRICAL CONNECTION

### Electrical connection

The electrical connection of the substation must be performed by a qualified and authorised electrician in compliance with all applicable rules and regulations.

The station should be connected to a 230 V AC power supply.

The power supply / connection must be carried out in accordance with the applicable regulations and instructions.

The station must be wired and connected to an external main switch so that it can be disconnected during maintenance, cleaning and repairs or in the event of an emergency.

**Do not forget** to establish potential equalization.

The VXe Solo are delivered with Danfoss ECL Comfort 310 controllers from factory.

The actuator and sensors are mounted in the station. The controller is built into the console at the top of the station.

The station is wired and tested in the factory.

Electrical connections between the controller, pump(s), sensor and actuator(s) are made.

### Mounting of outdoor temperature sensor (ESMT)

The outdoor temperature sensor is delivered separately and must be mounted on site according to the enclosed illustrations.

The outdoor sensor is always to be mounted on the coldest side of the property, where it is less likely to be exposed to direct sunshine (normally the north side of the property).

The sensor must not be exposed to the morning sun, and should not be placed above windows, doors, air vents or other heat sources, and not under balconies and roof eaves.

Mounting height approx. 2.5 m above ground.

Temperature range: -50 to 50° C.

### Electrical connections

The cables can be connected to the sensor in any order.

Connection cable: 2 x 0.4 - 1.5 mm<sup>2</sup>

For ECL 310:

Connect the cable ends to ECL controller in common ground terminal and in terminal 29.

### Access to ECL base part

Access to the base part for connection of outdoor sensor or the like is obtained by pulling the lock (pin) down with a screwdriver until a yellow line is visible on the lock. Then, the front piece can easily be removed. Lock by pressing the lock (pin) up.

### Controller ECL Comfort 310

Supply voltage: 230 V a.c. - 50 Hz  
 Voltage range: 207 to 244 V a.c. (IEC 60038)  
 Power consumption: 5 VA  
 Load on relay outputs: 4(2) A - 230 V a.c.  
 Load on triac outputs: 0,2 A - 230 V a.c.

### Actuator AMV 150

Supply voltage: 230 V a.c. - 50 Hz  
 Power consumption: 2 / 8 VA  
 For further information please see enclosed instruction manual.

### Pumpe UPM3 AUTO

Supply voltage: 230 V a.c. - 50 Hz  
 Protection class: IP44  
 Power consumption: Max. 52 Watt

For further information please refer to the enclosed instructions for the circulation pumps.

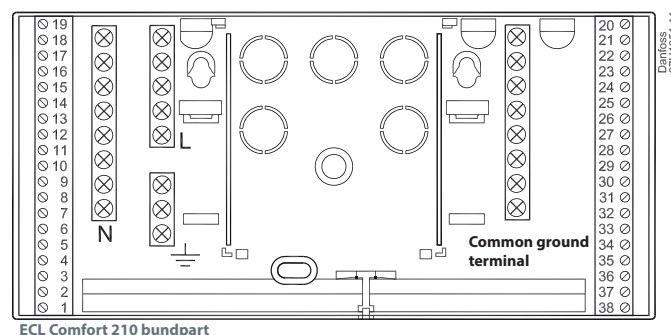
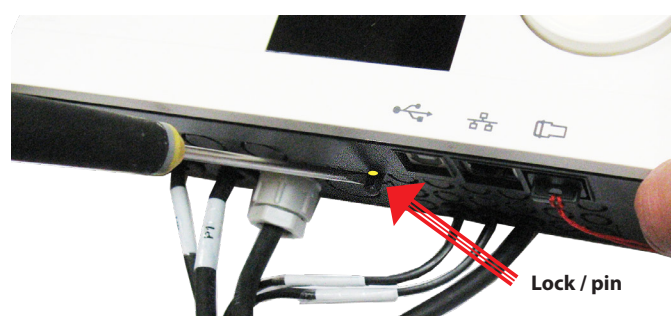
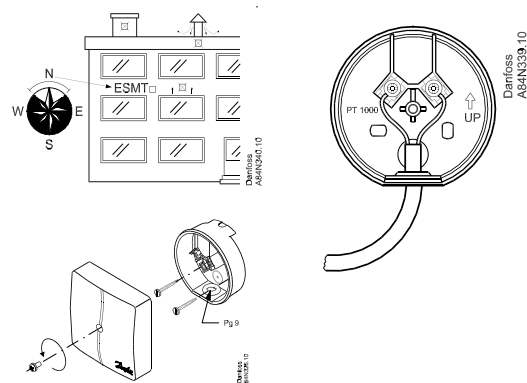

## 9. ADJUSTMENT AND COMMISSIONING

### General information

PLEASE NOTE! Some models may have a slightly different appearance, but the control function is in principle the same as described below.

### Commissioning

Commission the substation in accordance with the instruction manual.

### Filling the system / operating pressure

Fill the unit with water according to the instructions on page 16. If the pressure drops below 1 bar, water must be added to the system. The operating pressure should never exceed 1.5 bar. (The safety valve opens at 2,5 bar).

The pressure is read on the manometer.

If system pressure drops dramatically within a short time, heating system should be examined for leakage, - this includes checking the factory set pressure of the expansion vessel, which is normally 0,5 bar.

Fig. 1

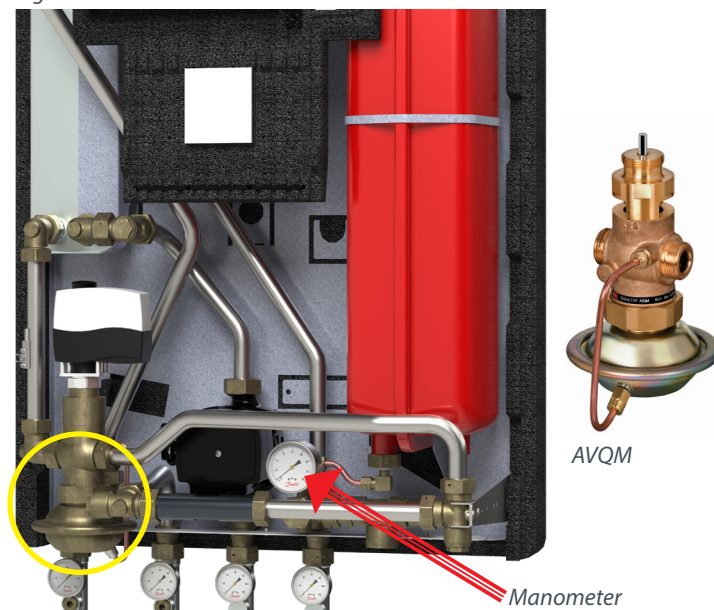

### Differential pressure controller

The differential pressure controller reduces the high, fluctuating pressure in the district heating network to a constant operating pressure.

### VXe Solo H (Fig. 1)

For VXe Solo H the differential pressure controller is installed in the AVQM self-acting flow controller with integrated control valve. Please see page 20 and relevant instruction manual.

### VXe Solo HWP (Fig. 2)

VXe Solo HWP is supplied with a AVPB-F differential pressure controller, which is preset from factory and should not be adjusted afterwards. The controller has a control valve with adjustable flow restrictor and flow setting is being done by the adjustment of the flow restrictor position. We suggest that you contact your local plumber for assistance. Please see page 20 and relevant instruction manual.

Fig. 2

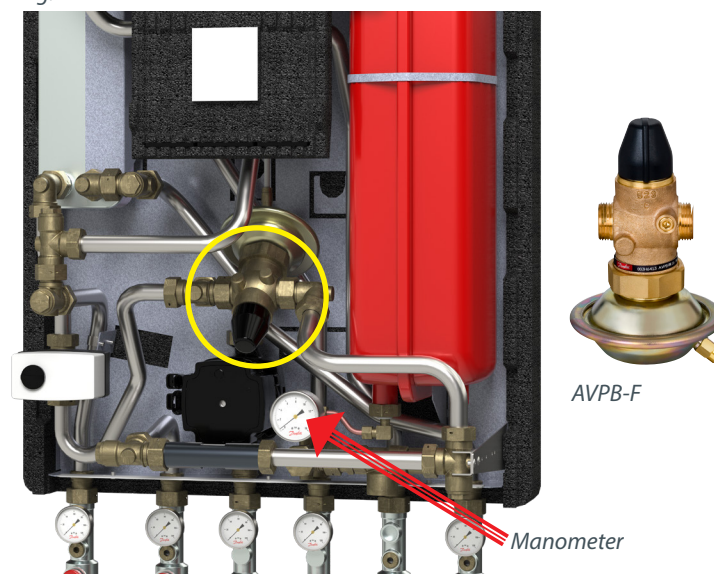
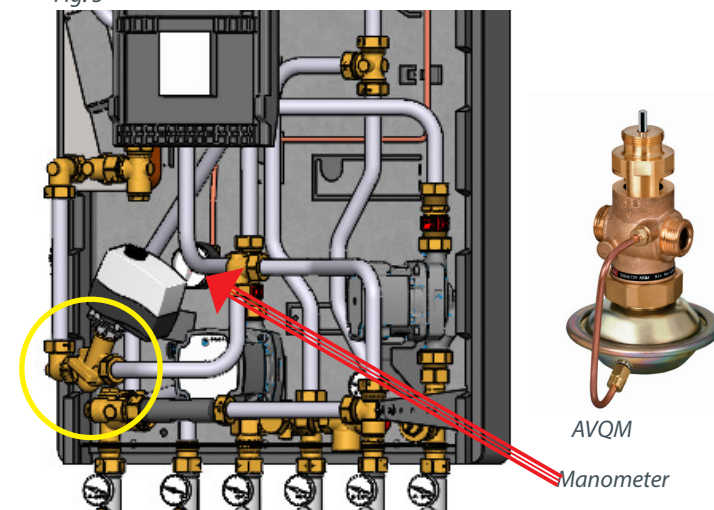

Fig. 3

### VXe Solo HWS (Fig. 3)

For VXe Solo HWS the differential pressure controller is installed in the AVQM self-acting flow controller with integrated control valve. Please see page 20 and relevant instruction manual.



## 10. HEATING CIRCUIT, DANFOSS ECL 310 AUTOMATICS

### Weather-compensated control of the heating circuit

#### Danfoss ECL 310

The temperature for the heating circuit is controlled electronically by the Danfoss ECL controller. The supply temperature is calculated by the controller on basis of the outdoor temperature.

The ECL Comfort controller is loaded with a selected application by means of an ECL Application Key (Plug-&-Play). The Application Key contains information about application, languages and factory settings. Various applications can be loaded by means of the ECL Application Key, and it is possible to update the controller with new application software.

The controller is factory preset to turn off the heating automatically in the summer period. The controller settings can be changed in accordance with the enclosed producer instructions for the mounted controller.

The controller is pre-programmed (normally) with the following factory settings:

- Language = English,
- Operating mode of the controller = Comfort "Sun" Symbol,
- Application type = A230 / A337 / A237

Motor speed and motor protection is set and the controller is functional is functionally tested, so it's ready for use.

#### Start-up of ECL 310 (easy start-up)

When the outside temperature sensor is properly installed and electrically connected to the controller as described in the instructions on page 15, proceed as follows:

1. Connect the controller and switch it on,
2. Choose 'MENU' in any circuit - Confirm and turn the dial and choose 'Common controller settings' in the circuit selector at the top right corner in the display,  
(You navigate in the controller by turning the dial left or right to the desired position. The position indicator in the display (◀) will always show you where you are).
3. Turn dial to select time and date,  
Push the dial to confirm the selection
4. Select time and date,
5. The controller is now ready for use. Set heat curve and temp. max. according to the procedure described below.

#### Setting / change of factory settings:

6. Choose 'MENU' in any circuit - Confirm and turn the dial and choose 'Heating circuit' in the circuit selector at the top right corner in the display (radiator symbol),
7. Then turn the dial and choose 'Settings' and confirm by pushing the dial. Then choose 'Flow temperature' and here you set 'Heat curve' (value), according to the actual system type, including "Temp. max.",
8. Typical setting ranges:

Heating circuit	one-string	two-string	Floor heating
Temp. max.	70-90°C	55-65°C	35-40°C
Heat curve	1,0 - 1,75	0,8 - 1,0	0,1 - 0,5

**Note;** in systems that feature only floor heating the max. supply temperature must be changed according to the above mentioned information.

If increased heat demand occurs during the heating period, the controller settings can be changed

[See ECL Application Key Box with ECL Comfort 210/310 user guide and mounting guide, for further information.](#)



Turn the dial to choose 'MENU' and press to confirm selection

Circuit selector  
Choose this symbol to enter 'Common controller settings'

Circuit selector  
Heating circuit

Settings  
Flow temperature: 1.0  
Heat curve: 1.0  
Temp. max.: 90 °C  
Temp. min.: 10 °C

Flow temperature  
Heat curve: 1.0

## 11. CONTROL OF HEATING CIRCUIT

### Actuator and valve, VXe Solo H

For controlling the heating circuit the VXe Solo H, VXe Solo HWS and VXe Solo H OP are supplied with a self-acting flow controller with integrated control valve Danfoss AVQM and a Danfoss AMV actuator placed in the primary return flow line. The AMV actuator is electrically wired to the controller from the plant. The control valve closes on rising differential pressure and opens on falling differential pressure to control max flow. The controller closes when set max. flow is exceeded.

In the combination with the electrical actuator AMV and ECL electronic controller the flow and temperature can be controlled to achieve highest energy savings. The AVQM is equipped with excess pressure safety valve, which protects control diaphragm for flow control from too high differential pressure.

### AMV 150

The actuator has undergone a functional test and is preset from factory.

In the event of operating disturbances the actuator can be shut off manually by turning the manual override knob on top of the actuator clockwise. Please note that the knob can be "tight" to turn.

### AMV 13

The actuator has undergone a functional test and is preset from factory.

Depending on the selected setting of the safety function, the AMV 13 valve is fully opened or closed when the voltage supply is switched off.

**For additional information see manuals for:**  
**Self-acting flow controller with integrated control valve and actuator AVQM**  
**Electronic actuator AMV 150**  
**Electronic actuator AMV 13**

### Actuator and valve, VXe Solo HWP

For controlling the heating circuit the VXe Solo HWP is supplied with a Danfoss AMV 150 / AMV 13 actuator and a Danfoss two-way motorized control valve VS 2, placed on the primary return flow line. The AMV actuator is electrically wired to the controller from factory.

The actuator has undergone a functional test and is preset from factory.

In the event of operating disturbances the AMV 150 actuator can be shut off manually by turning the manual override knob on top of the actuator clockwise. Please note that the knob can be "tight" to turn.

Depending on the selected setting of the safety function, the AMV 13 valve is fully opened or closed when the voltage supply is switched off.

**For additional information see manuals for:**  
**Electronic Actuator AMV 150**  
**Electronic Actuator AMV 13**  
**Danfoss Valve VS 2**

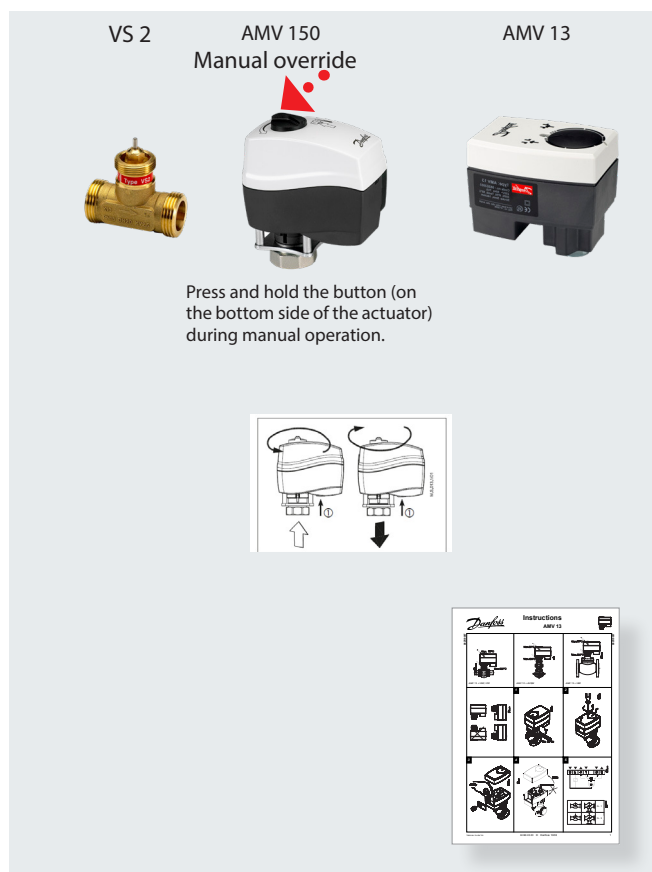
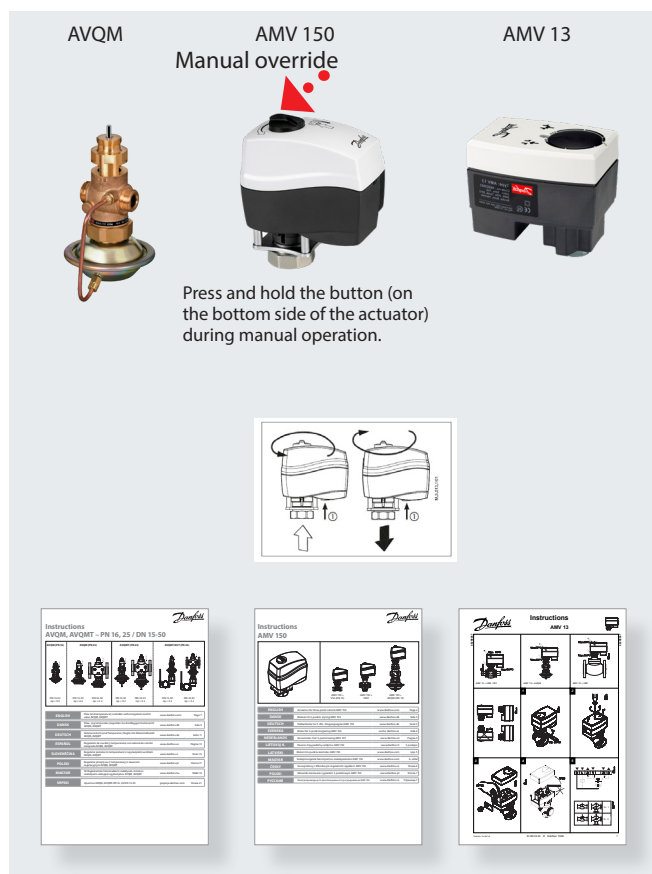

## 11. CONTROL OF HEATING CIRCUIT

### Safety function, Jumo AT

The heating circuit(s) can be supplied with a safety thermostat Jumo AT for protection against overheating.

From factory the Jumo AT safety thermostat is pre-wired to the Danfoss ECL controller with a 2 m cable, enabling the thermostat housing to be mounted in any mounting position on the household piping (HE supply) on site.

**For additional information see the enclosed manuals for: Jumo AT**

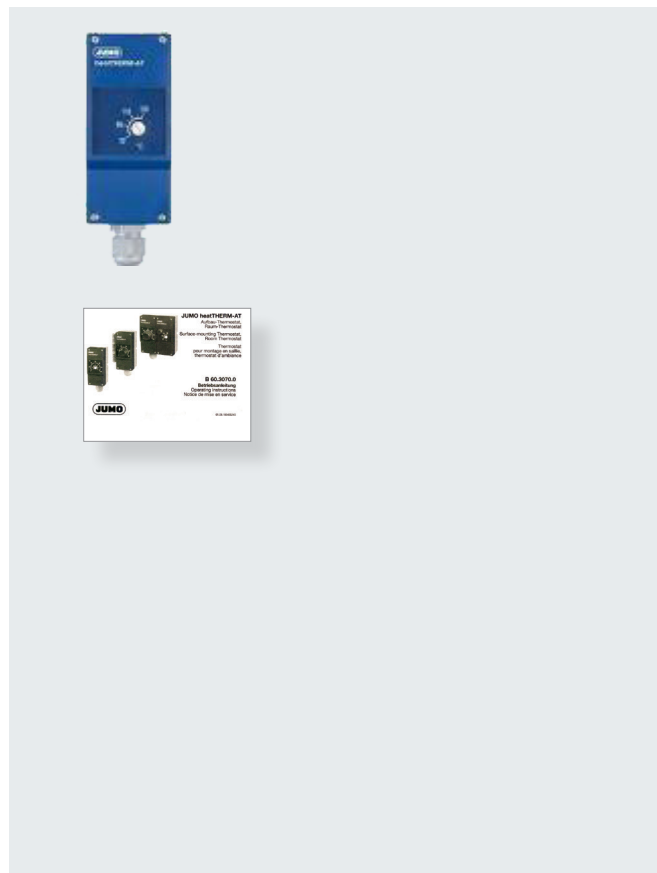

### Wiring diagrams

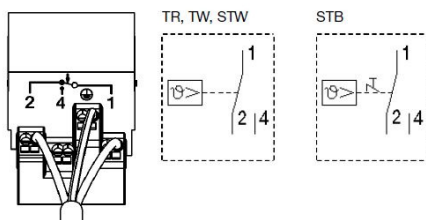

## 12. HEATING CIRCUIT, PUMP

### Grundfos Pump UPM3 AUTO

Grundfos UPM3 Auto has 12 optional settings, which can be selected with the push-button. **See fig. 1 - User interface.**

The pump is set from factory to Proportionaldruck Pressure 2 .



Abb. 1. Bedienfeld mit einer Drucktaste und fünf LED's

The user interface shows:

- \* performance view (during operation)
  - operation status
  - alarm status
- \* settings view (after pressing the button)

During operation, the display shows the performance of the pump. By pressing the button, the display changes status or you can change settings.

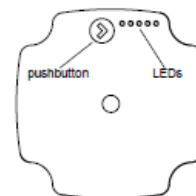

The LEDs show the power consumption for the pump. When the pump is running, LED 1 is green. The four yellow LEDs indicate the current power consumption.

**See fig. 2 - Performance view.**

Fig. 2. Performance view

Performance % of P <sub>1</sub> max.	LED 1	LED 2	LED 3	LED 4	LED 5
0% (standby)	●				
0 - 25%	●	●			
25 - 50%	●	●	●		
50 - 75%	●	●	●	●	
75 - 100 %	●	●	●	●	●

## 12. HEATING CIRCUIT, PUMP

Check the pump setting by pressing the button once (one constant pressure). The LEDs will briefly (2 sec.) show the pump setting before changing back to showing the power consumption.

See fig. 3 - Pump setting view.

If the pump setting does not give the desired distribution of heat in the rooms of the house, change the pump setting. See fig. 3 - Pump setting view.

Before starting the setting, make clear what the display should show for the new setting (see fig. 3).

To change the pump setting, choose the setting you want (see fig. 3), press the button down for more than 2 seconds (less than 10) and the pump switches to setting selection, the LEDs start flashing and display the current setting. Then press the button until the LEDs show the desired setting. The LEDs flash and when they stop the new setting is saved. The LEDs return to show power consumption.

**Please note** that if the LEDs do not flash after 2 seconds, possibly the pump setting is locked. To unlock, press the button down for more than 10 seconds. LEDs will flash and the pump is unlocked. To lock the pump, repeat the procedure.

**For more information, see enclosed Grundfos instructions.**



Fig. 3. Pump setting view

Funktion	Application	Pump mode				
PROPORTIONAL PRESSURE AUTO ADAPT	- Two-pipe systems	●				
CONSTANT PRESSURE AUTO ADAPT	- One-pipe systems - Floor heating		●			
PROPORTIONAL PRESSURE 1	- Two-pipe systems <i>small systems</i>	●		●		
PROPORTIONAL PRESSURE 2	- Two-pipe systems <i>middle-sized system</i>	●		●	●	
PROPORTIONAL PRESSURE 3	- Two-pipe systems <i>large systems</i>	●		●	●	●
CONSTANT PRESSURE 1	- One-pipe systems - Floor heating <i>small systems</i>		●	●		
CONSTANT PRESSURE 2	- One-pipe systems - Floor heating <i>middlesized- systems</i>		●	●	●	
CONSTANT PRESSURE 3 - MAX.	- Floor heating - One-pipe systems <i>large systems</i>		●	●	●	●
CONSTANT CURVE 1	- One-pipe systems - Charging systems <i>small systems</i>			●		
CONSTANT CURVE 2	- One-pipe systems - Charging systems <i>middle-sized systems</i>			●	●	
CONSTANT CURVE 3 - MAX.	- One-pipe systems - Charging systems - Venting of installation <i>large systems</i>			●	●	●



### Alarm status

In case the 1st LED is red the pump has detected one or more alarms.

See fig. 4 - Alarm status.

When there is no active alarm anymore the user interface switches back to operation mode shortly and then showing power consumption.

Fig. 4. Alarm status

Function	LED 1	LED 2	LED 3	LED 4	LED 5
Blocked	●				●
Supply voltage low	●			●	
Electrical error	●		●		

### 13. DOMESTIC HOT WATER

**General information**

PLEASE NOTE! Some models may have a slightly different appearance, but the control function is in principle the same as described below.

**General**

The **VXe Solo HWP (Fig. 1)** is supplied with connection pipes for cylinder on the primary side and the **VXe Solo HWS (Fig. 2)** is supplied with connection pipes for cylinder on the secondary side.

**VXe Solo HWP**

Please note that domestic hot water cylinder control is not included in the standard delivery.

For temperature regulation of the DHW cylinder the **VXe Solo HWP** can, as an option, be equipped with a **RAVK self-acting thermostat** and a **2-way valve VMA** - for installation outside the system.

The controller closes when the temperature rises.

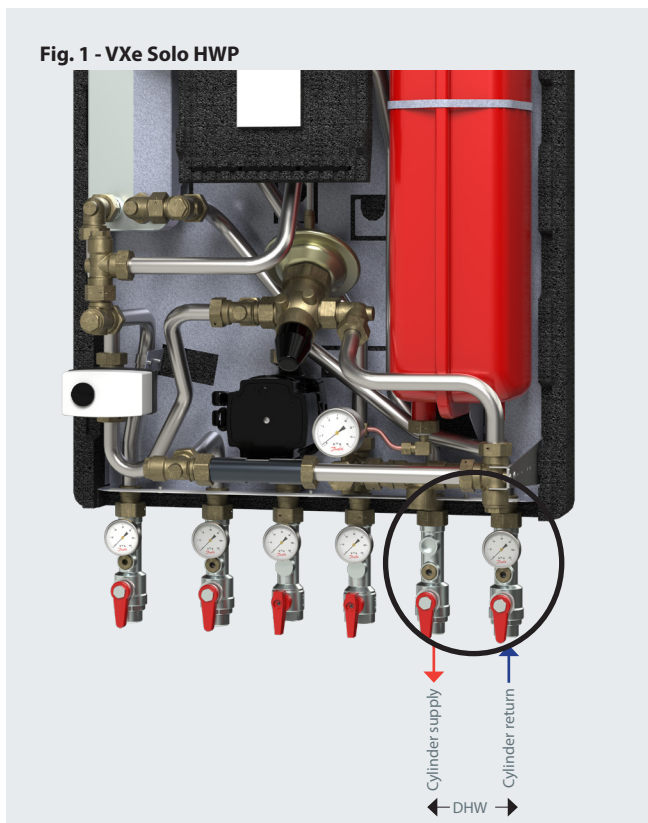
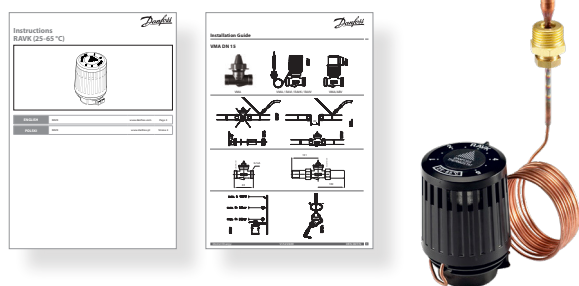

Fig. 1 - VXe Solo HWP

**VXe Solo HWS**

For VXe Solo HWS the temperature in the cylinder is controlled by the Danfoss ECL controller in combination with the self-acting flow controller with integrated control valve Danfoss AVQM and actuator AMV 150, according to the cylinder temperature, measured by the cylinder sensor.

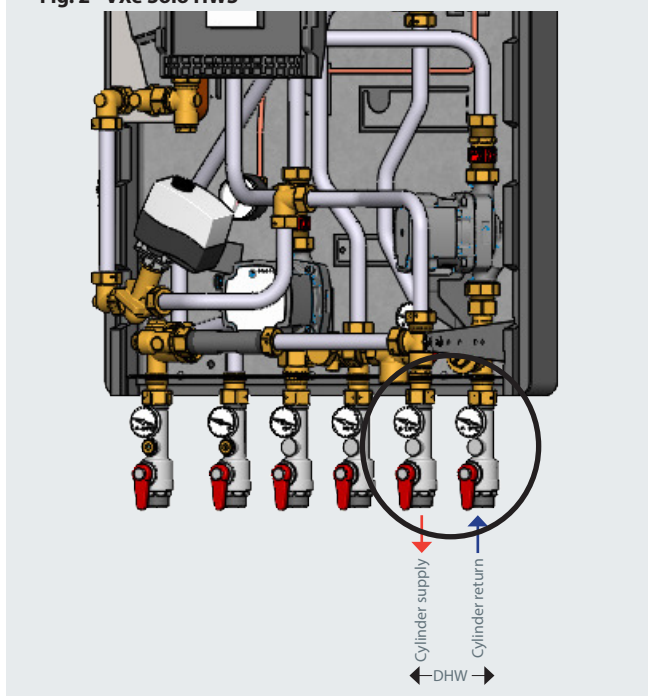

Fig. 2 - VXe Solo HWS

**Danfoss ECL Comfort 310**

The application Key contains information about application, language and factory settings, adapted to the type of system, for which it is ordered.

Note! Various applications can be loaded.

The controller is factory-set for local language and the running time for the actuator (DHW circuit) is preset for the actual application. General controller settings such as "Time and Date" must be entered during commissioning of the controller. And also the desired DHW temperature must be set.

(Make sure that the immersion sensor is placed correctly before making adjustment of the temperature).

Please refer to the enclosed manufacturer instructions for the ECL 210/310 controller in order to **set the required domestic hot water temperature in the DHW cylinder circuit:**

**ECL Application Key Box with ECL Comfort 210/310 user guide and mounting guide, for further information.**

We recommend that your order commissioning of the controller with your local Danfoss Sales Company.





### 13. DOMESTIC HOT WATER

Below schedule states whether the VXe Solo is supplied with connection pipes for DHW cylinder on the primary side or the secondary side, and whether the DHW temperature in the cylinder is controlled by the electronic controller and also states the controller application and the actuator/valve combination.

Type	Primary Connection for Cylinder	Secondary Connection for Cylinder	Pump for cylinder circuit
VXe Solo HWP (ECL310/337)	Control not part of delivery		
VXe Solo HWS (ECL310/A337)		Danfoss ECL 310, Application A337 (AVQM / AMV 150)	Grundfoss UPM3 Auto

#### VXe Solo HWP with primary connection for cylinder

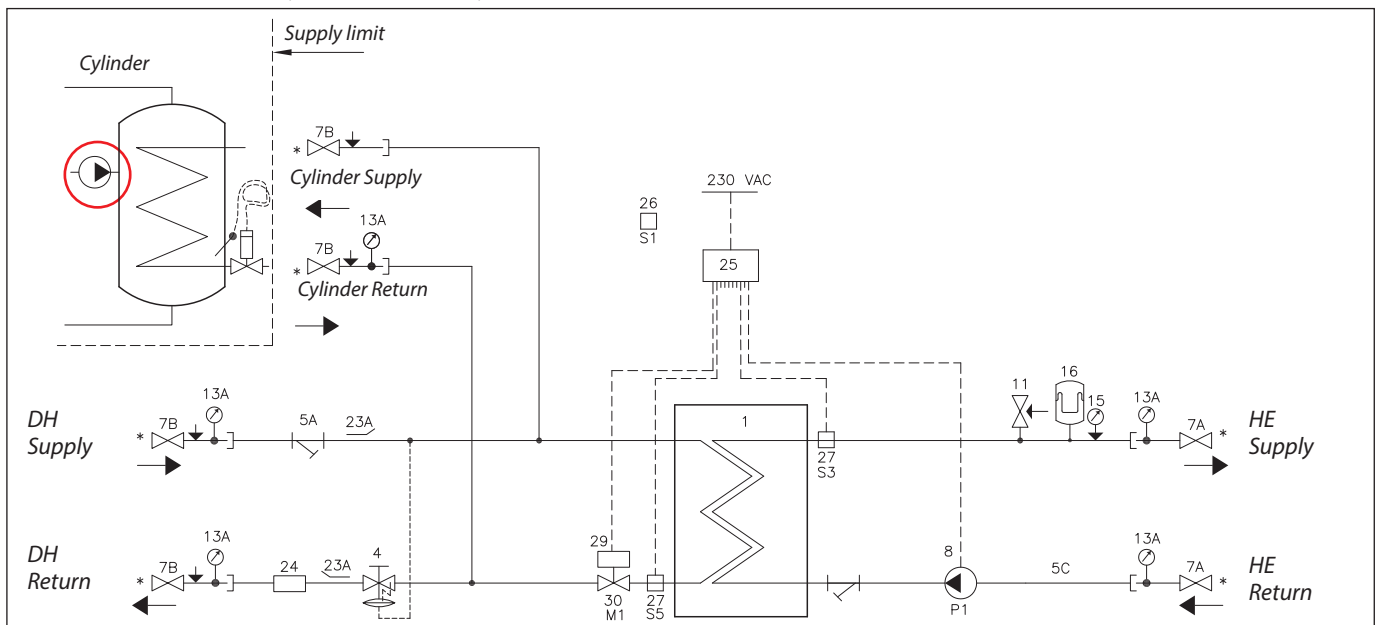

#### VXe Solo HWS with secondary connection for cylinder

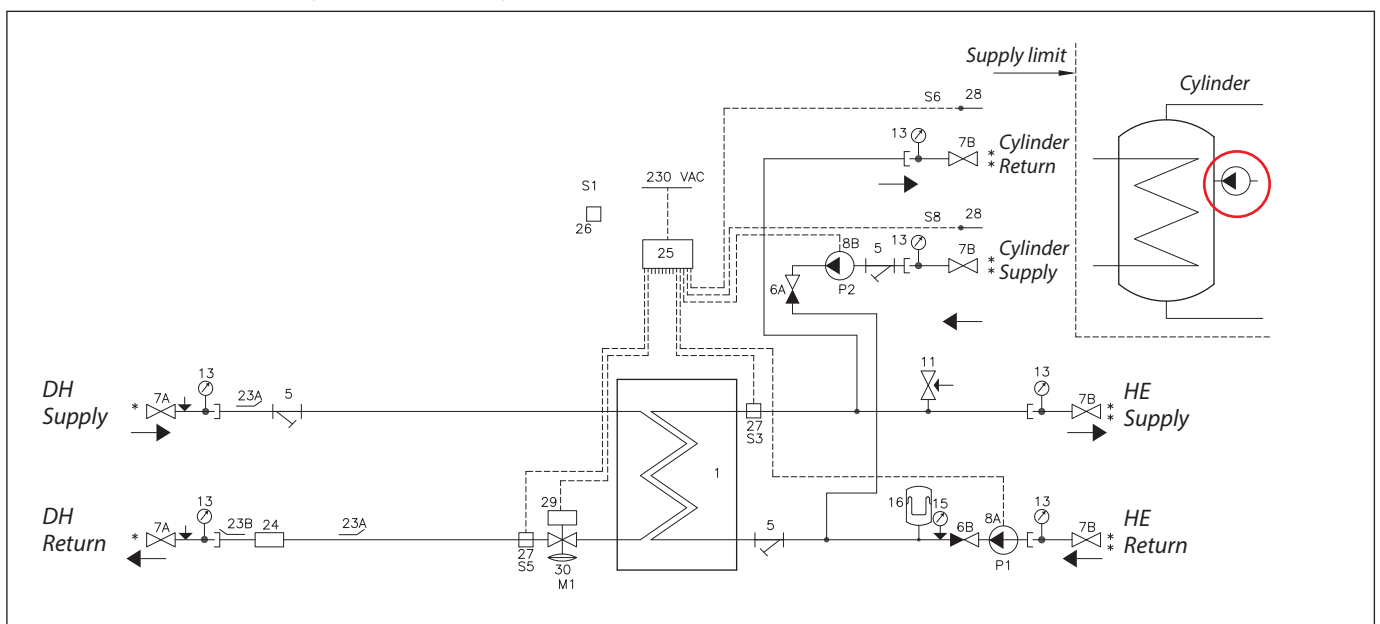

### 13. DOMESTIC HOT WATER

For VXe Solo HWS (ECL 310/A237) the temperature in the DHW cylinder is controlled by the electronic controller in combination with the self-acting flow controller with integrated control valve Danfoss AVQM and actuator AMV 13, according to the cylinder temperature, measured by the cylinder sensor.

The AMV actuator is electrically wired to the controller from the plant.

The actuator has undergone a functional test and is preset from factory.

Depending on the selected setting of the safety function, the AMV 13 valve is fully opened or closed when the voltage supply is switched off.

**For additional information see manuals for:  
Self-acting flow controller with integrated control valve and actuator AVQM  
Electronic actuator AMV 13**

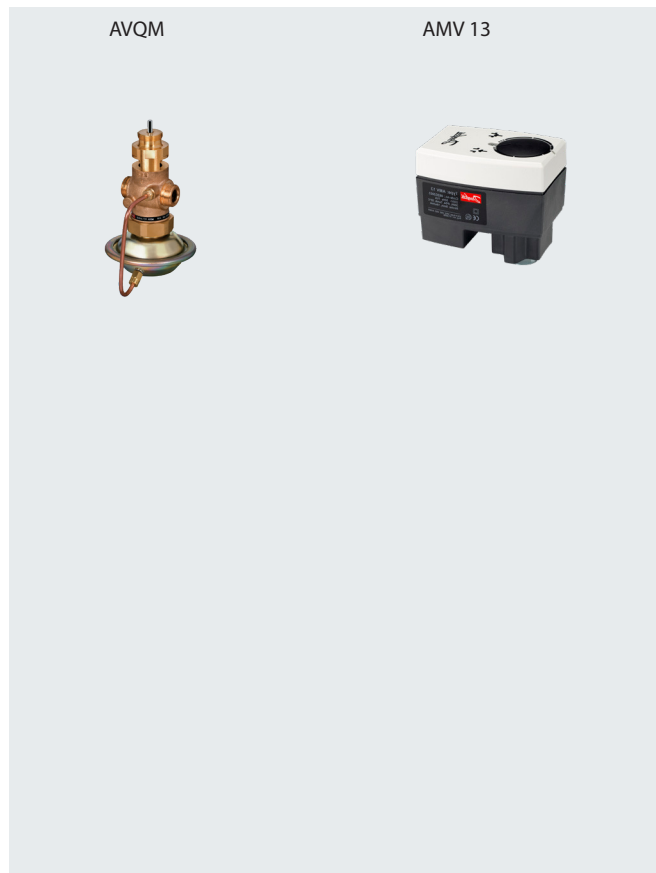

### PUMP, DHW CYLINDER CIRCUIT

**Domestic hot water circulation pump**

VXe Solo HWS with connection pipes for domestic hot water cylinder on the secondary side is fitted with a circulation pump Grundfos UPM3 Auto from factory.

The pump is controlled by the cylinder sensor and ECL controller in combination.

**For more information, see Grundfos pump instructions and Danfoss ECL application key instructions.**

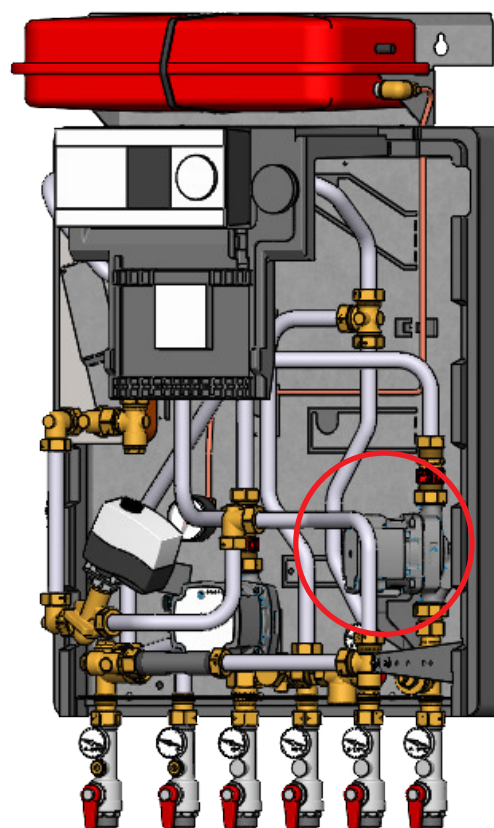

## 14. MAINTENANCE

### Maintenance work

Is only to be carried out by qualified and authorised personnel.

### Inspection

The water heater should be checked regularly by authorised personnel. Any necessary maintenance must be performed in accordance with the instructions in this manual and other sets of instructions. During service the dirt strainers are to be cleaned – including the filter on the controller, all pipe connections must be tightened and the safety valve must be function tested by turning the lever.



### Rinsing/cleaning of plate heat exchanger

To clean the plate heat exchanger, rinse it by running clean water through the exchanger at high speed and in the opposite direction to the normal flow. This will remove any dirt deposits that may have built up in the exchanger. If rinsing with clean water is not sufficient, the exchanger can also be cleaned by circulating a cleaning agent approved by Danfoss (e.g. Kaloxi or Radiner FI cleaning fluid) through the exchanger. Both these cleaning fluids are environmentally friendly and can be disposed off through the standard sewer system. After use of a cleaning fluid, the plate heat exchanger must be rinsed thoroughly with clean water.

### Acidification of brazed plate heat exchanger

As a starting point, we do not recommend acidification of the exchanger. Deposits of limescale may build up in plate heat exchangers for domestic hot water on account of the large temperature fluctuations, and because aerated water is used on the secondary side. If it becomes necessary to clean the exchanger with acid, this can be done as shown on the drawing to the right. Brazed plate heat exchangers can withstand rinsing with a dilute acid solution - e.g. 5% formic, acetic or phosphoric acid).

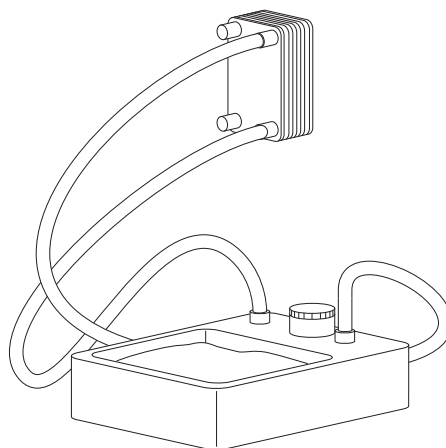

### Measures after maintenance work

After maintenance work and before commissioning:

- Check that all screwed connections are tight.
- Check that all safety features, covers, that were removed, have been replaced properly.
- Clean the working area and remove any spilled materials.
- Clear all tools, materials and other equipment from the working area.
- Connect to energy supply and check for leaks.
- Vent the system.
- Carry out any necessary adjustment again.
- Make sure that all safety features on the device and the system work properly.

### Meter reading

The caretaker/owner must perform visual checking and reading of the district heating meter at short, regular intervals. (The meter is not a part of the delivery from Danfoss).

Service procedures must only be performed by trained, authorised personnel.

NB! Excessive consumption for whatever reason is not covered by the Danfoss warranty.

### Cooling / Return temperature reading

Cooling – i.e. the difference between the supply and return temperature of the district heating water – has a significant effect on overall energy economy. Therefore, it is important to focus on the supply and return temperature in the heating system. The difference should typically be 30–35°C. Please note that a low district heating return temperature is directly related to the return temperature from the heating circuit and the return temperature of the circulation water. It is therefore important to focus on these return temperatures.



#### Please note

Use of other types of packaging, than the ones, with which the unit is delivered, will lead to the loss of warranty.

## 14. MAINTENANCE SCHEDULE (recommendations)

Interval	Maintenance work	Comments
At least once per month*	Read the meter and check the system and all connections for leaks	Enter the measured readings in the control book - contact qualified and authorised personnel in the event of leaks or other irregularities
	Check the pipes and exchanger for signs of corrosion. Check for visible signs of coatings (typically white coatings or green irises) on the surface of the exchanger or pipes	Visual control In the event of coatings or green irises on the surface of the exchanger, the exchanger must be replaced immediately by qualified and authorised personnel
	Check all connections for leaks	If you identify a leak, replace the gaskets and retighten the pipe connections
At least once a year*	Check all connections for leaks	If you identify a leak, replace the gaskets and retighten the pipe connections
	Check that the safety valve on the cold water supply is functioning correctly.	Check the functionality by turning the lever on the safety valves
	Check that all components are intact and functioning as intended	In the event of irregularities, lack of functionality or visible faults and defects in a component, replace the component in question
	Clean all dirt filters/strainers in the substation	Replace any filters that are not intact
	Check that any electrical cables are in serviceable condition and that it is possible to disconnect the electrical power supply to the substation	Visual check. Check whether it is possible to disconnect the current to the substation.
	Check the pipes and exchanger for signs of corrosion	Visual check
	Check that the insulation cover is intact	Make sure that the insulation cover encloses the substation tightly
	Check that the temperature regulators are set in accordance with the instructions in this manual	Follow the instructions in the present manual
	Check the functions of all shut-off valves	Check that the ball valves open and close as they should

\*)Enduser/caretaker.

Note! After maintenance work has been carried out all gaskets HAVE to be replaced.

## 15. TROUBLESHOOTING HE

### Fundamental

In the event of disruptions to operation, you should fundamentally - before commencing the actual troubleshooting - check whether:

- check the pipes and exchanger for signs of corrosion. check for visible signs of coatings (typically white coatings or green irises) on the surface of the exchanger or pipes
- the system is correctly connected
- the district heating supply temperature is at its normal level
- the differential pressure is at its normal level. Ask your district heating supplier if necessary
- there is a power supply to the system - pump and automatics
- the dirt strainer in the district heating supply pipe is clean
- there is air in the system (if the system is vented)

Problem	Possible cause	Solution
Too little or no heat.	Strainer clogged in DH or HE circuit (radiator circuit).	Clean gate/strainer(s).
	The filter in the energy meter on DH circuit clogged.	Clean the filter (after consulting the DH plant operator).
	Defective or improperly adjusted differential pressure controller	Check the operation of the differential pressure controller – clean the valve seat if required.
	Sensor defective.	Check the operation of the thermostat – clean the valve seat if required.
	Automatic controls wrongly set or defective - possibly power failure.	Check if the setting of the controller is correct – see separate instructions. Check the power supply. Temporary setting of motor to “manual” control – see instructions on automatic controls.
	Pump out of operation.	Check if the pump is receiving power and that it turns. Check if there is air trapped in the pump housing – see pump manual.
	The pump is set at too low speed of rotation.	Set the pump at higher speed of rotation.
	Air pockets in the system.	Vent the installation thoroughly.
	Limiting of the return temperature adjusted too low.	Adjust according to instructions.
	Defective radiator valves.	Check – replace.
	Uneven heat distribution in building because of incorrectly set balancing valves, or because there are no balancing valves.	Adjust/install balancing valves.
	Diameter of pipe to flat station too small or branch pipe too long.	Check pipe dimensions.
Uneven heat distribution.	Air pockets in the system.	Vent the installation thoroughly.
DH supply temperature too high.	Defective controller. The controller does not react as it should according to the instructions.	Set the automatic controls according to the instructions.
	Defective control valve.	Replace control valve .
DH supply temperature too low.	Defective controller. The controller does not react as it should according to the instructions.	Set the automatic controls according to the instructions.
	Strainer clogged.	Clean gate/strainer.

## 15. TROUBLESHOOTING HE

Too high DH return temperature.	Too small heating surface/too small radiators compared to the total heating requirement of the building.	Increase total heating surface.
	Poor utilization of existing heating surface. Defective sensor on self-acting thermostat.	Make sure the heat is distributed evenly across the full heating surface – open all radiators and keep the radiators in the system from heating up at the bottom. It is extremely important to keep the supply temperature to the radiators as low as possible, while maintaining a reasonable level of comfort.
	The system is single pipe loop.	Das System sollte mit elektronischen Reglern und Rücklauffühlern ausgestattet sein.
	Pump pressure too high.	Pumpe niedriger einstellen.
	Air in system.	System entlüften.
	Defective or incorrectly set radiator valve(s). Single pipe loop systems require special one-pipe radiator valves.	Check – set/replace.
	Dirt in the differential pressure controller.	Check – clean out.
	Defective motorized valve, sensor or automatic controller.	Check – replace.
Noise in system.	Pump pressure too high. Noice from radiator valves.	Adjust pump to a lower level. Check flow direction.
Heat load too high.	Defective motorized valve, sensor or electronic controller.	Check – replace.

	<p><b>Disposal</b> This product should be dismantled and its components sorted, if possible, in various groups before recycling or disposal. Always follow the local disposal regulations.</p>
--	--

## 15. TROUBLE SHOOTING - DOMESTIC HOT WATER

### Fundamental

In the event of disruptions to operation, you should fundamentally - before commencing the actual troubleshooting - check whether:

- the system is correctly connected
- the district heating supply temperature is at its normal level
- the differential pressure is at its normal level. Ask your district heating supplier if necessary
- there is a power supply to the system - pump and automatics
- the dirt strainer in the district heating supply pipe is clean
- there is air in the system (if the system is vented)

Problem	Possible cause	Solution
Too little or no domestic hot water	Dirt strainer in the district heating supply line clogged.	Clean the dirt strainer.
	Charging pump pump out of operation or set too low.	Check whether the pump is running - whether the pump is receiving power. Control that there is no air in the pump housing - see pump manual.
	Defective actuator - or possibly dirt in the valve housing.	Check the functions of the actuator - clean valve seat if required.
	No power	Check
	Automatic controls wrongly set or defective - possibly power failure.	Check if the setting of the controller is correct, - see separate instructions. Check the power supply; Temporary setting of actuator to "manual" control - see instructions on heating circuit, manual control.
	Calified plate heat exchanger	Replace
	Defective actuator or thermostat	Check according to encl. manual - replace
	Defective or clogged non-return valve.	Replace or clean
	Defective immersion sensor.	Replace sensor.
Hot water is available only at some taps	Inadequate cylinder capacity.	Wait for heating / loading of the cylinder. You may check the specifications of the manufacturer conc. cylinder capacity.
	Cold and warm drinking water mix, e.g. in a defective thermostatic mixing valve.	Check - replace
DHW temperature too high	Non-return valve on the circulation line defective (leads to mixing - and the circulation water pipes become cold during tapping).	Replace the non-return valve
	Thermostatic valve RAVK/VMA set to high	Check - adjust
Declining temperature during tapping	Calified heat exchanger	Replace
Temperature control valve does not close	The temperature difference between the supply flow and the DHW setpoint is too low.	Choose a lower DHW setpoint or increase the supply water temperature.
Poor cooling	Calified heating element	Clean DHW cylinder with acid solution or replace heating element.

## 15. TROUBLE SHOOTING - DOMESTIC HOT WATER

Temperature falls during tapping (lack of capacity)	Controller incorrectly adjusted or defective.	Check that the setting of the controller is correct. - see the controller instruction manual.
	The immersion thermostat sensor incorrectly fitted in the cylinder.	Place sensor correctly according to the specifications of the manufacturer. You may contact Danfoss Redan A/S for further information.
	Calified heating element.	Descale the heat exchanger or replace it.
Temperature too high	Defective actuator - possibly dirt in the valve housing.	Check the functions of the actuator - clean valve seat if required.
	Automatic controls wrongly set or defective.	Check if the setting of the controller is correct, - see separate instructions.
	Defective immersion sensor.	Replace immersion sensor.
No DHW	Calified heating element. Insufficient cylinder capacity	Clean DHW cylinder with acid solution or replace heating element.



16. EU DECLARATION OF CONFORMITY

ENGINEERING  
TOMORROW



**Danfoss A/S**

6410 Nordborg  
Denmark  
CVR nr.: 20 16 57 15

Telephone: +45 7488 2222  
Fax: +45 7449 0949

**EU DECLARATION OF CONFORMITY**

**Danfoss A/S**

Danfoss Redan

declares under our sole responsibility that the

**Product category:**

Small substations with electrical equipment

**Type designation(s):**

VX 22, S 22 and VX Solo 22

Akva Vita TD, Akva Vita TDP, Akva Vita S and Akva Vita VX,

Akva Lux TD, Akva Lux TDP and Akva Lux S,

Akva Lux II S-unit and Akva Lux II VX/VXI,

Akva Les II S-unit and Akva Les II VX/VXI,

Akva Lux Se and VXe

VX2000 and Akva Lux II VX-F

Akva lux II TDP-F, Akva Lux II S-F, Complete S-F,

EvoFlat FSS, EvoFlat MSS and EvoFlat Four Pipe

Akva Therm 22, 28, 35, and Akva Therm LV

Distribution module CI, GRI, SGC and SGTZC

OEM Shunt

Covered by this declaration is in conformity with the following directive(s), standard(s) or other normative document(s), provided that the product is used in accordance with our instructions.

**Machinery Directive 2006/42/EC**

EN 60204-1/A1:2009, Safety of machinery – Part 1 - General Requirements.

EN 12100:2011, Safety of machinery – Risk assessment.

**Low Voltage Directive (LVD) – 2014/35/EU**

EN 60730-1:2012, Safety of machinery – Part 1 – General Requirements

<p>Date: 2021.02.28 Place of issue: Silkeborg</p>	<p>Issued by  <b>Signature:</b> <b>Name:</b> Jan Bennetsen <b>Title:</b> Engineering Specialist</p>	<p>Date: 2021.02.28 Place of issue: Silkeborg</p>	<p>Approved by  <b>Signature:</b> <b>Name:</b> Henrik Ellegaard <b>Title:</b> Quality and EHS Supervisor</p>
---	--	---	---

Danfoss only vouches for the correctness of the English version of this declaration. In the event of the declaration being translated into any other language, the translator concerned shall be liable for the correctness of the translation

## 17. COMMISSIONING CERTIFICATE

The substation is the direct link between the district heating supply network and the household piping system. All supply pipes and the pipes in the household piping system must be checked and rinsed before commissioning. Once the system has been filled with water, all pipe connections must be retightened before performing pressure test for leaks. The dirt strainers must be cleaned and the substation must be adjusted in accordance with the instructions in this manual.

It is important to comply with all technical regulations and the applicable legislation in every respect.

Installation and commissioning must only be performed by trained, authorised personnel.

The substation is checked in the factory for leaks before delivery. Leaks are however possible due to vibrations caused by transport, handling and heating of the system and therefore it is important to check all connections and to retighten if necessary before commissioning. Please note that the connections may feature EPDM gaskets! **Therefore it is important that you DO NOT OVER-TIGHTEN the connections.** Over-tightening may result in leaks. Leaks caused by over-tightening or failure to retighten connections are not covered by the warranty.

### To be filled-out by the installer

This substation has been retightened, adjusted and commissioned

on the: \_\_\_\_\_  
Date/Year

by installer: \_\_\_\_\_  
Company name (stamp)

## 18. GUIDELINES FOR WATER QUALITY IN DANFOSS BRAZED HEAT EXCHANGERS

ENGINEERING  
TOMORROW



Danfoss A/S  
Danfoss Heating Segment - DEN  
BU HEX - Local Inspection Center Kamnik Slovenia

### Guidelines for water quality in Danfoss brazed heat exchangers with plates of EN 1.4404 ~ AISI 316L

Danfoss has prepared this guideline for the water quality of tap water and district heating water used in plate heat exchangers of stainless steel (EN 1.4404 ~ AISI 316L) brazed with pure copper (Cu), copper -nickel (CuNi) or Stainless Steel (StS). It is important to point out that the water specification is not a guarantee against corrosion, but it must be considered as a tool to avoid the most critical water applications.

Parameter	Unit	Value or concentration	Plate	Brazing material		
			AISI 316L W.Nr. 1.4404	Cu	CuNi	StS
pH		< 6.0	o	-	-	o
		6,0 – 7.5	+	o/-	o	+
		7.5 – 10.5	+	+	+	+
		>10.5	+	o	o	+
Conductivity	µS/cm	<10	+	+	+	+
		10 – 500	+	+	+	+
		500 – 1000	+	o	+	+
		>1000	+	-	o	+
Free Chlorine	mg/l	<0.5	+	+	+	+
		0.5 – 1	o	+	+	+
		1 – 5	-	o	o	o
		>5	-	-	-	-
Ammonia (NH <sub>3</sub> , NH <sub>4</sub> <sup>+</sup> )	mg/l	<2	+	+	+	+
		2 – 20	+	o	o	+
		>20	+	-	-	+
Alkalinity (HCO <sub>3</sub> <sup>-</sup> )	mg/l	<60	+	+	+	+
		60 – 300	+	+	+	+
		>300	+	o	+	+
Sulphate (SO <sub>4</sub> <sup>2-</sup> )	mg/l	<100	+	+	+	+
		100 – 300	+	o/-	o	+
		>300	+	-	-	+
HCO <sub>3</sub> <sup>-</sup> / SO <sub>4</sub> <sup>2-</sup>	mg/l	>1.5	+	+	+	+
		<1.5	+	o/-	o	+
Nitrate (NO <sub>3</sub> )	mg/l	<100	+	+	+	+
		>100	+	o	+	+
Manganese (Mn)	mg/l	<0.1	+	+	+	+
		>0.1	+	o	o	+
Iron (Fe)	mg/l	<0.2	+	+	+	+
		>0.2	+	o	+	+
* Hardness ratio [Ca <sup>2+</sup> , Mg <sup>2+</sup> ]/[HCO <sub>3</sub> <sup>-</sup> ]	/	0 – 0.3	+	-	-	+
		0.3 – 0.5	+	o/-	+	+
		>0.5	+	+	+	+

+	<b>Good corrosion resistance</b>
o	<b>**Corrosion could happen when more parameters are evaluated with o</b>
o/-	<b>Risk of corrosion</b>
-	<b>Use is not recommended</b>

\* Hardness ratio limits defined per experience and internal tests in Danfoss laboratory  
\*\* In case of three or more parameters evaluated with o consultancy is needed with Consultant for Corrosion & Microbiology or BU HHE Representative

Recommended Chloride concentration to avoid Stress Corrosion Cracking (SCC) in the stainless-steel plates:

Application temperature	Chloride concentration
at T ≤ 20°C	max 1000 mg/l
at T ≤ 50°C	max 400 mg/l
at T ≤ 80°C	max 200 mg/l
at T ≥ 100°C	max 100 mg/l



ENGINEERING  
TOMORROW

*Danfoss*

**Danfoss A/S**

Heating Segment • danfoss.com • +45 7488 2222 • E-Mail: heating@danfoss.com

---

Danfoss can accept no responsibility for possible errors in catalogues, brochures and other printed material. Danfoss reserves the right to alter its products without notice. This also applies to products already on order provided that such alterations can be made without subsequential changes being necessary in specifications already agreed. All trademarks in this material are property of the respective companies. Danfoss and the Danfoss logotype are trademarks of Danfoss A/S. All rights reserved.

---