

Data sheet

SonoSensor 30

Ultrasonic flow sensor

Description



Features

- Available in nominal flow rates q_p 0.6, 1.0, 1.5, 2.5, 3.5, 6.0, 10.0, 15.0, 25.0, 40.0, and 60.0 m^3/h
- Housings with thread (G3/4 to G2) or flange (DN20 to DN100) connections
- MID approval for ultrasonic flow meter with dynamic range of 1:100 ($q_i:q_p$) in class 2
- Optional dynamic range of 1:250 in class 2 (with the exceptions of sensors q_p 0.6 m^3/h , 1.0 m^3/h and 3.5 m^3/h)
- Temperature range: 5 - 130 °C
- Operating pressure PN 16 or PN 25 bar
- Flow sensor with IP65 protection class and IP67 for heating/cooling application.
- Battery lifetime not less than 12 years
- Low pressure loss, insensitive to dirt
- No inlet or outlet restrictions up to DN50
- Short overload temperature up to 150 °C

MID examination certificate no.:
LT-1621-MI004-030

SonoSensor 30 is an ultrasonic flow sensor especially designed for heating, cooling or combined heating/cooling application in local and district energy systems. It can be used in conjunction with the type approved heating/cooling energy calculator (e.g. Infocal 9) to form combined heating/cooling energy meter. SonoSensor 30 has been approved according to MID in accuracy class 2. The flow sensor can be mounted in both flow and return pipe.

Technical specifications

Diameter	DN 15		DN 20				DN25, DN32			DN40	DN 50	DN 65	DN 80	DN 100
Connection type	G¾		G1				G1¼			G2	FL	FL	FL	FL
Overall length, mm	110	110; 165	190		130		260			300	270	300	300	360
Flow rate														
Nominal, m3/h	0.6	1.5	0.6	1.5	2.5	1.5	2.5	3.5	6.0	10	15	25	40	60
Maximum, m3/h	1.2	3.0	1.2	3.0	5.0	3.0	5.0	7	12	20	30	50	80	120
Minimum, l/h	6	6	15	6	6	15	10	25	15	10	25	35	24	60
Starting flow rate, l/h	3	3	3	3	5	5	5	17	12	20	30	120	200	300
Pressure loss at qp, mbar	70	171	90	58	94	72	198	40	100	180	120	200	180	180
Max. operating pressure	Thread 16 bar Flange 25 bar									25 bar				
Flow sensor temp. range	5 to 130°C (short overload 150°C)													
Flow sensor to electronic box cable length	1.2m up to DN32 2.5m up to DN40 to DN100													
Medium	Water quality with pH 7 to 9.5													
Volume measuring cycles	1 second													
Supply voltage	3.6V DC Lithium battery (AA-cell)/ Mains supply 24V AC/DC Mains supply 230V AC (with external 230V to 24V AC transformer)													
Battery lifetime	Not less than 12 years													
Approval	EN1434 class 2													
Environmental class	class C													
Ambient class	E2 + M1													
Protection class	IP65 (IP67 for heating/cooling)													
Ambient operating temp.	+5°C to +55°C													
Max. ambient humidity	<93% rel. humidity													

Accuracy graph

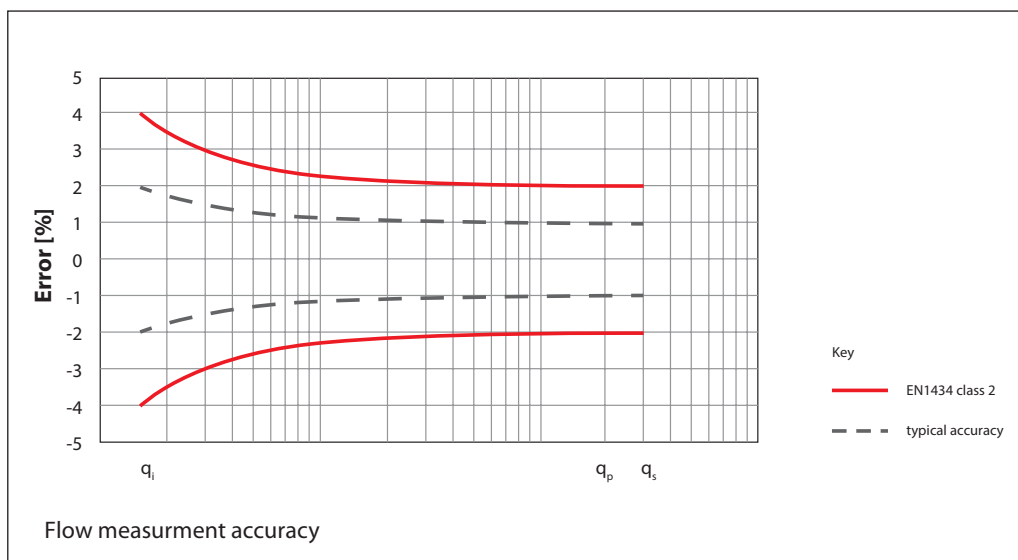

Design and function

Power supply

Standard version contains AA cell 3,6V, 2,4 Ah lithium battery with a lifetime not less than 12 years. It is also possible to have two internal lithium batteries (same type) with lifetime not less than 16 years. Optionally external power supply (12V..42V DC or 12C...36V, 50/60Hz AC, 10mA) + internal backup battery is available as accessory. External power supply module is mounted inside in the meter.

Pulse output

Measured flow rate is converted into the volume pulses which are transferred through pulse output terminal. Pulse output class of flow output device: OD according to EN1434-2 + AC:2007. Maximum flow cable length (from electronic box to energy calculator or pulse reading device) is up to 100m.

Mounting

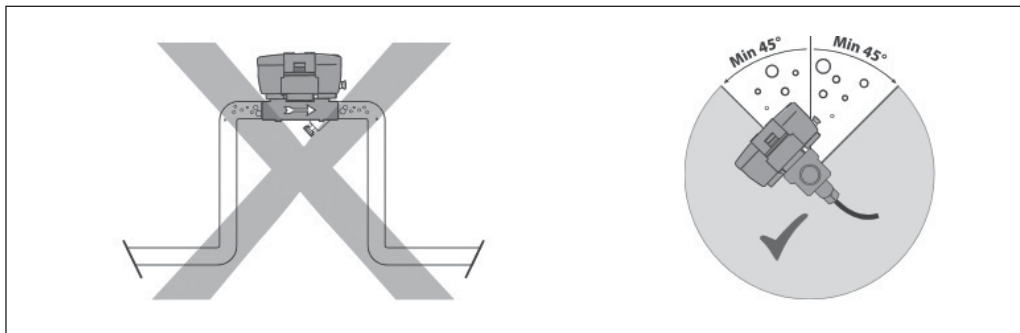

Pipe position:

No limitations but avoid positions where air can be collected.

Rotation in pipe axis:

Flow sensor should be angled in 45 to 315° to avoid air collection in flow sensor.

Inlet/outlet conditions

SonoSensor 30 sizes from DN15 to DN50 don't need any calming sections before and after the flow sensor.

To secure optimal conditions for flow measurement for sizes DN65, DN80 and DN100 it is necessary to have straight inlet and outlet flow conditions 5xDN before and 3xDN after the flow sensor.

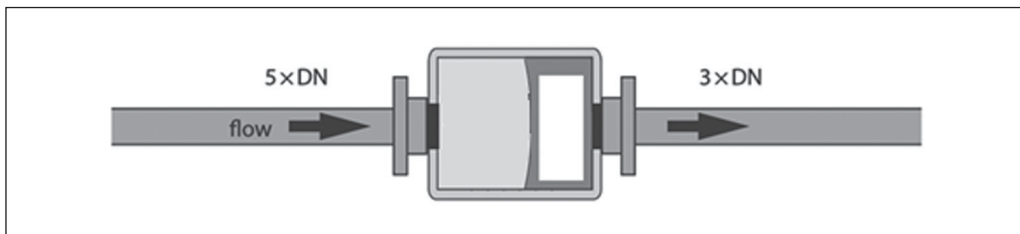

Inlet/outlet conditions

SonoSensor 30 in return pipe	Infocal 9 terminal
18 (flow pulse)	52 (q2+)
19 (ground)	11 (q2-)

SonoSensor 30 in supply pipe	Infocal 9 terminal
18 (flow pulse)	10 (q1+)
19 (ground)	11 (q1-)

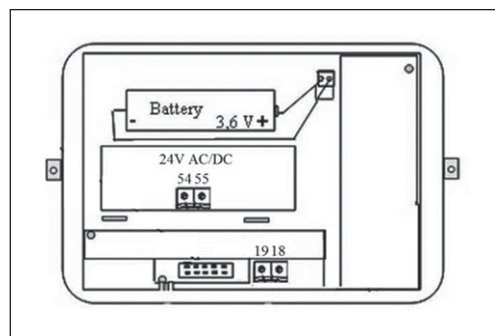

Dimensions

DN15, DN20 thread

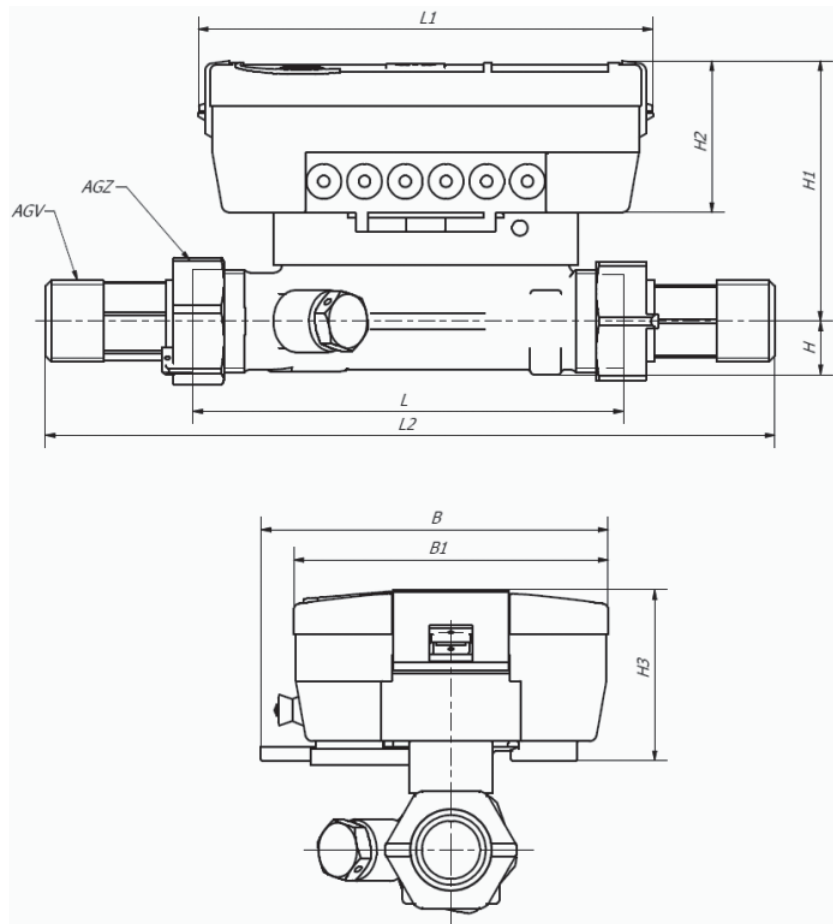

Nominal flow rate	q _p	m ³ /h	0.6/1/1.5	1.5/2.5	0.6/1/2.5
Nominal diameter	DN	mm	15	20	20
Overall length	L	mm	110	130	190
Overall length with coupling	L2	mm	185	224	284
Length of calculator	L1	mm	117	117	117
Height	H	mm	14	18	18
Height	H1	mm	67	67	68
Height of calculator	H2	mm	39	39	39
Height of calculator	H3	mm	44	44	44
Width	B	mm	90	90	90
Width of calculator	B1	mm	81	81	81
Connection thread of meter	AGZ	inch	G $\frac{3}{4}$ B	G1B	G1B
Connection thread of coupling	AGV	inch	G $\frac{3}{4}$ B	G $\frac{3}{4}$ B	G $\frac{3}{4}$ B
Weight	-	kg	0.8	0.9	1.0

Dimensions
(continuous)

DN25 thread

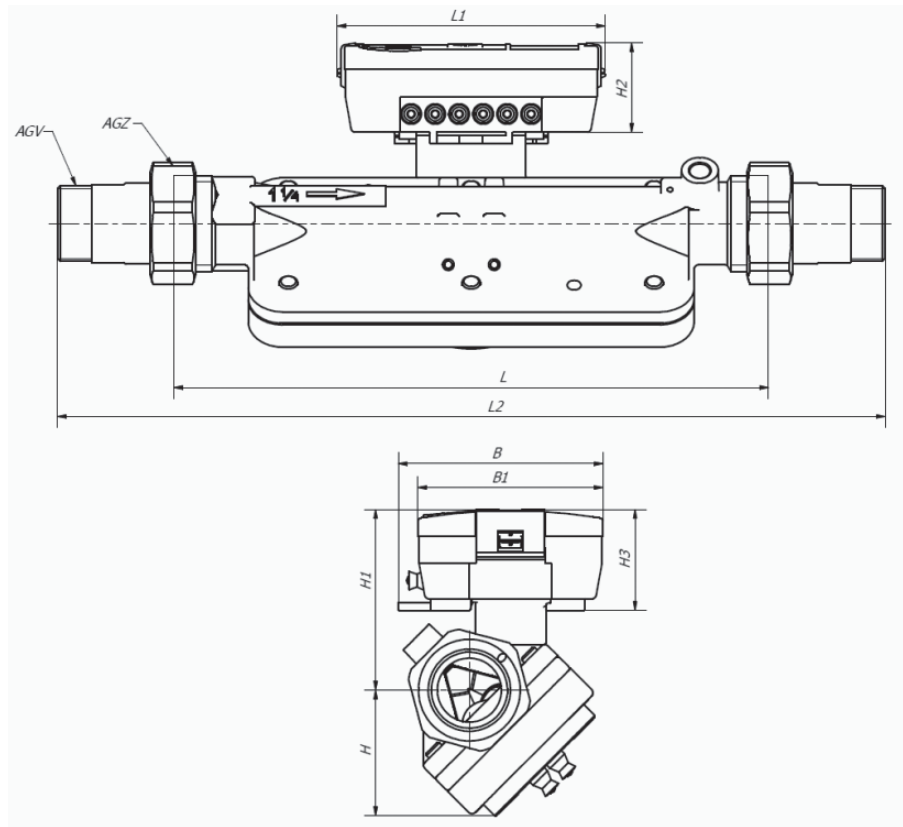

Nominal flow rate	q _p	m ³ /h	3.5/6
Nominal diameter	DN	mm	25
Overall length	L	mm	260
Overall length with coupling	L2	mm	360
Length of calculator	L1	mm	117
Height	H	mm	55
Height	H1	mm	79
Height of calculator	H2	mm	39
Height of calculator	H3	mm	44
Width	B	mm	90
Width of calculator	B1	mm	81
Connection thread of meter	AGZ	inch	G1 ¼B
Connection thread of coupling	AGV	inch	G1 B
Weight	-	kg	3.6

Dimensions
(continuous)

DN40 thread

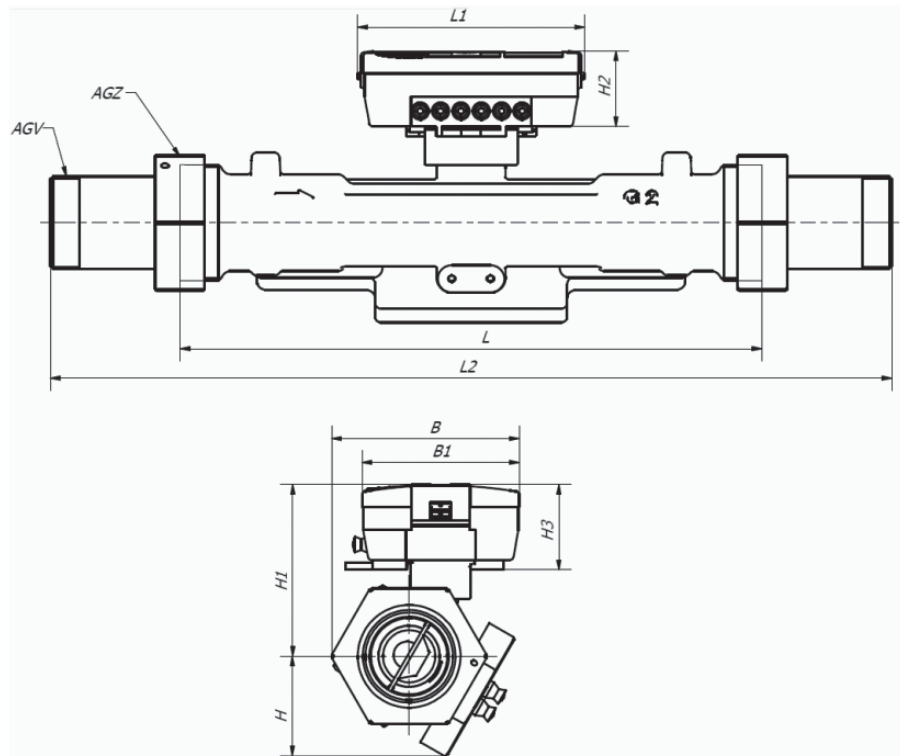

Nominal flow rate	q _p	m ³ /h	10
Nominal diameter	DN	mm	40
Overall length	L	mm	300
Overall length with coupling	L2	mm	437
Length of calculator	L1	mm	117
Height	H	mm	51
Height	H1	mm	89
Height of calculator	H2	mm	39
Height of calculator	H3	mm	44
Width	B	mm	97
Width of calculator	B1	mm	81
Connection thread of meter	AGZ	inch	G2B
Connection thread of coupling	AGV	inch	G1 ½ B
Weight	-	kg	7.2

Dimensions
(continuous)

DN20, DN25, DN40, DN50 flange

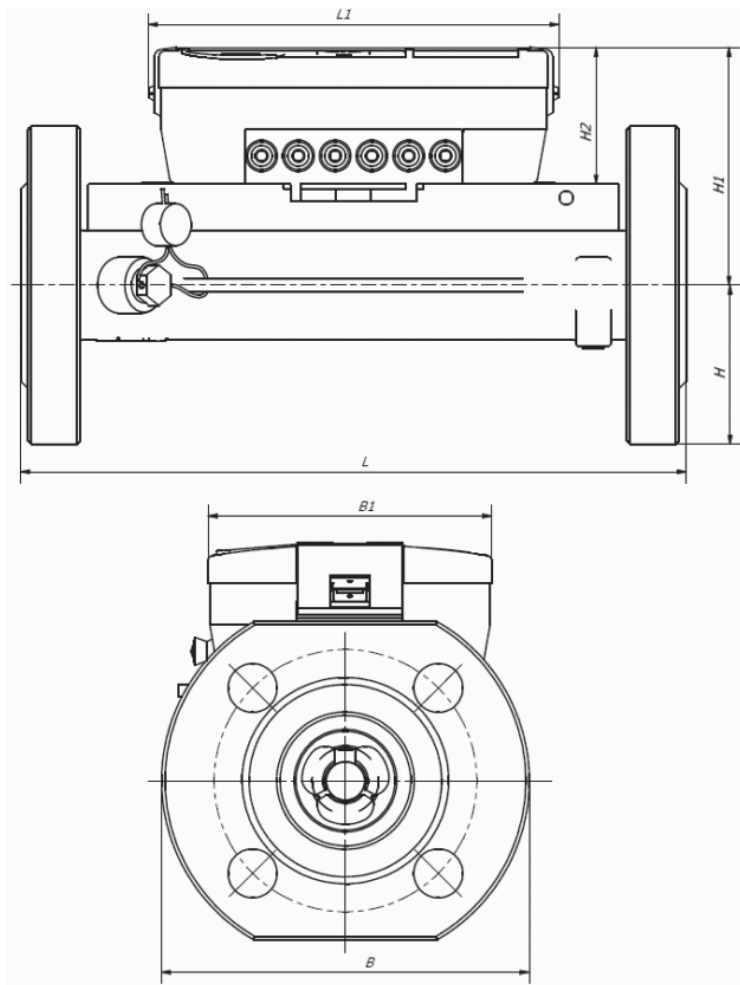

Nominal flow rate	q _p	m ³ /h	0.6/1/1.5/2.5	3.5/6	10	15
Nominal diameter	DN	mm	20	25	40	50
Overall length	L	mm	190	260	300	270
Length of calculator	L1	mm	117	117	117	117
Height	H	mm	46	58	73	79
Height	H1	mm	68	78	91	90
Height of calculator	H2	mm	39	39	39	39
Width	B	mm	105	116	150	159
Width of calculator	B1	mm	81	81	81	81
Connection flange of meter	DN _{FL}	mm	20	25	40	50
Weight	-	kg	2.5	5.6	6.8	8.5

Dimensions
(continuous)

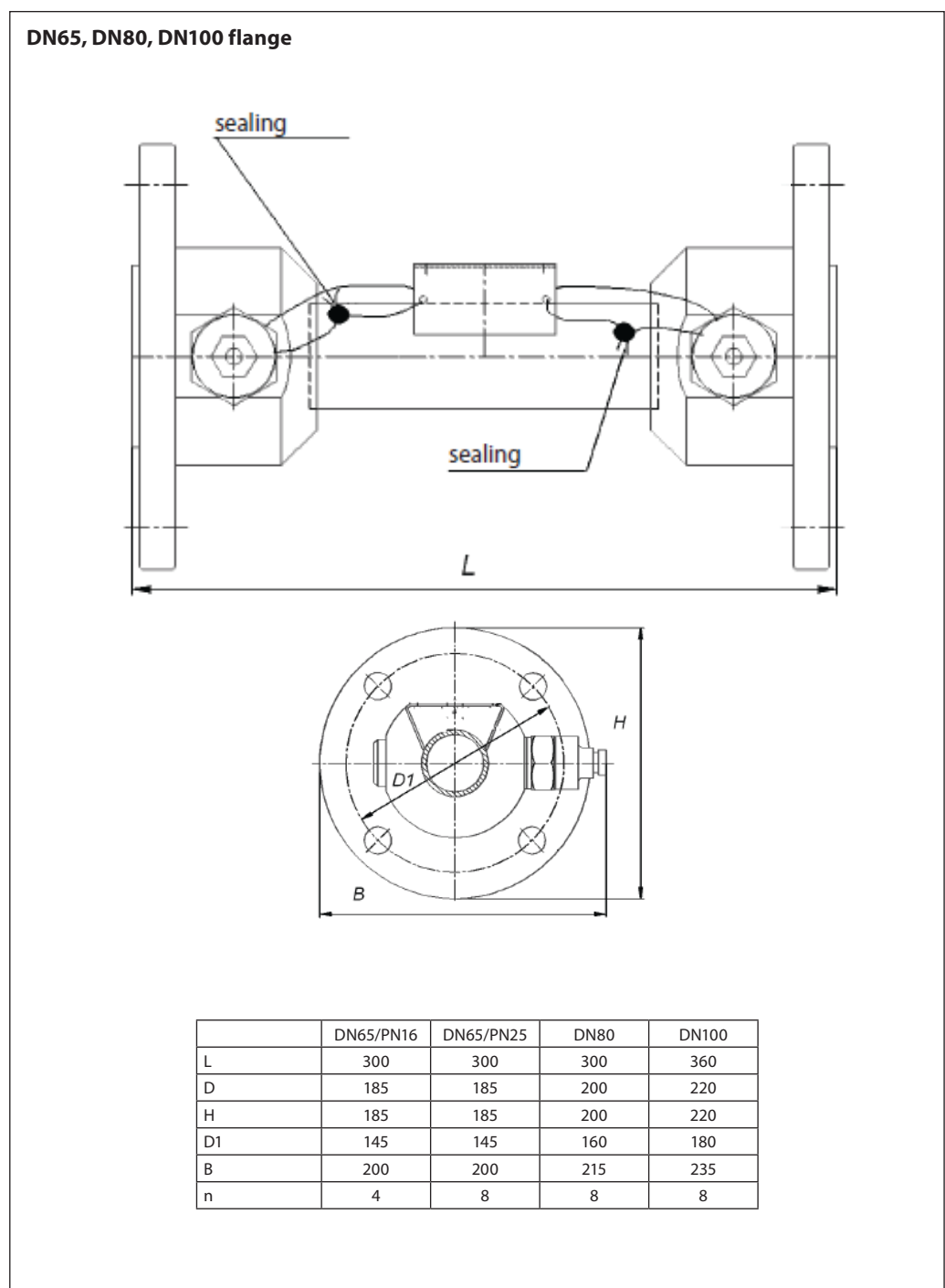

Ordering

Heating application SonoSensor 30 standard codes:

Nominal flow rate, size and connection type	Pulse Weight	Nominal pressure	Cable length transducer cable	Power supply	Code no.
DN15 qp0.6 m ³ /h G3/4 110mm	1 l/p	PN16	1.2m	Battery 3.6V DC (1 AA-cell)	187F3700
	1 l/p	PN16	5m	Battery 3.6V DC (1 AA-cell)	187F3741
	0,03 l/p	PN25	1.2m	Battery 3.6V DC (1 AA-cell)	187F3771
DN15 qp1.5 m ³ /h G¾ 110mm	1 l/p	PN16	1.2m	Battery 3.6V DC (1 AA-cell)	187F3701
	1 l/p	PN16	5m	Battery 3.6V DC (1 AA-cell)	187F3742
	0,08 l/p	PN25	1.2m	Battery 3.6V DC (1 AA-cell)	187F3772
DN20 qp2.5 m ³ /h / G1 130mm	1 l/p	PN16	1.2m	Battery 3.6V DC (1 AA-cell)	187F3702
	1 l/p	PN16	5m	Battery 3.6V DC (1 AA-cell)	187F3743
	0,12 l/p	PN25	1.2m	Battery 3.6V DC (1 AA-cell)	187F3773
DN20 qp2.5 m ³ /h G1 190mm	1 l/p	PN16	1.2m	Battery 3.6V DC (1 AA-cell)	187F3703
	1 l/p	PN16	5m	Battery 3.6V DC (1 AA-cell)	187F3744
DN25 qp3.5 m ³ /h/ G1¼ 260mm	1 l/p	PN16	1.2m	Battery 3.6V DC (1 AA-cell)	187F3704
	1 l/p	PN16	5m	Battery 3.6V DC (1 AA-cell)	187F3745
	0,17 l/p	PN25	1.2m	Battery 3.6V DC (1 AA-cell)	187F3774
DN25 qp6.0 m ³ /h G1¼ 260mm	1 l/p	PN16	1.2m	Battery 3.6V DC (1 AA-cell)	187F3706
	1 l/p	PN16	5m	Battery 3.6V DC (1 AA-cell)	187F3747
	0,24 l/p	PN25	1.2m	Battery 3.6V DC (1 AA-cell)	187F3775
DN32 qp3.5 m ³ /h flange 260mm	1 l/p	PN25	1.2m	Battery 3.6V DC (1 AA-cell)	187F3705
	1 l/p	PN25	5m	Battery 3.6V DC (1 AA-cell)	187F3746
DN32 qp6.0 m ³ /h flange 260mm	1 l/p	PN25	1.2m	Battery 3.6V DC (1 AA-cell)	187F3707
	1 l/p	PN25	1.2m	Battery 3.6V DC (1 AA-cell)	187F3740
	1 l/p	PN25	5m	Battery 3.6V DC (1 AA-cell)	187F3748
	1 l/p	PN25	5m	Battery 3.6V DC (1 AA-cell)	187F3748
DN40 qp10 m ³ /h flange 300mm	10 l/p	PN25	2.5m	Battery 3.6V DC (1 AA-cell)	187F3709
	10 l/p	PN25	5m	Battery 3.6V DC (1 AA-cell)	187F3750
DN40 qp10 m ³ /h G2 300mm	10 l/p	PN25	2.5m	Battery 3.6V DC (1 AA-cell)	187F3708
	10 l/p	PN25	5m	Battery 3.6V DC (1 AA-cell)	187F3749
	0,5 l/p	PN25	2.5m	Battery 3.6V DC (1 AA-cell)	187F3776
DN50 qp15 m ³ /h flange 270mm	10 l/p	PN25	2.5m	Battery 3.6V DC (1 AA-cell)	187F3710
	10 l/p	PN25	5m	Battery 3.6V DC (1 AA-cell)	187F3751
	0,8 l/p	PN25	2.5m	Battery 3.6V DC (1 AA-cell)	187F3777
DN65 qp25 m ³ /h flange 300mm	10 l/p	PN25	2.5m	Battery 3.6V DC (1 AA-cell)	187F3711
	10 l/p	PN25	5m	Battery 3.6V DC (1 AA-cell)	187F3752
	1,1 l/p	PN25	2.5m	Battery 3.6V DC (1 AA-cell)	187F3778
DN80 qp40 m ³ /h flange 300mm	10 l/p	PN25	2.5m	Battery 3.6V DC (1 AA-cell)	187F3712
	10 l/p	PN25	5m	Battery 3.6V DC (1 AA-cell)	187F3753
	1,6 l/p	PN25	2.5m	Battery 3.6V DC (1 AA-cell)	187F3779
DN100 qp60 m ³ /h flange 360mm	10 l/p	PN25	2.5m	Battery 3.6V DC (1 AA-cell)	187F3713
	10 l/p	PN25	5m	Battery 3.6V DC (1 AA-cell)	187F3754
	2,3 l/p	PN25	2.5m	Battery 3.6V DC (1 AA-cell)	187F3780

All flow sensors are battery powered, minimum lifetime 12 years

Accessories

Flow sensor application	Designation	Quantity	Code no.
Optical head	Optical head OG-1-USB	1 pc	187F3112
	Battery 3.6 V DC (AA cell)	1 pc	187F3113
Power supply	Mains unit 230 V AC (external module)	1 pc	187F3114
	Mains unit 24 V AC/DC	1 pc	187F3115
Tailpiece connection set	DN15 G3/4"-R1/2" PN25 130 °C	1 pair	087G6071
	DN20 G1"-R3/4" PN25 130 °C	1 pair	087G6072
	DN25 G1 1/4"-R1" PN25 130 °C	1 pair	087G6073
	DN40 G2"-R1 1/2" PN25 130 °C	1 pair	087G6074



Danfoss A/S

Climate Solutions • danfoss.com • +45 7488 2222

Any information, including, but not limited to information on selection of product, its application or use, product design, weight, dimensions, capacity or any other technical data in product manuals, catalogues descriptions, advertisements, etc. and whether made available in writing, orally, electronically, online or via download, shall be considered informative, and is only binding if and to the extent, explicit reference is made in a quotation or order confirmation. Danfoss cannot accept any responsibility for possible errors in catalogues, brochures, videos and other material. Danfoss reserves the right to alter its products without notice. This also applies to products ordered but not delivered provided that such alterations can be made without changes to form, fit or function of the product.

All trademarks in this material are property of Danfoss A/S or Danfoss group companies. Danfoss and the Danfoss logo are trademarks of Danfoss A/S. All rights reserved.