

ENGINEERING
TOMORROW

Danfoss

Marine and Offshore

Expand your efficiency horizons
with powerful VLT[®] and VACON[®] drive
and grid systems

**Total
range**

for Marine and
Offshore needs



drives.danfoss.com

VLT | **VACON**

Dampskibsselskabet NORDEN A/S

*"We save 30,000 USD
per year on each vessel
with drives. And we have
used Danfoss' setup on
all new vessels based on
our experiences with the
retrofit solution."*

Martin Meldgaard, fleet manager
for producttanker vessels at
Dampskibsselskabet NORDEN A/S

 [Read the story](#)



Single port of call

No matter what your motor control question, you can find the answer at Danfoss Drives. Obtain the optimum AC drive for the job, whatever the application is on board the ship. With a global presence and more than 40 years of experience, Danfoss Drives offers a complete low voltage portfolio of VLT® and VACON® drives for marine and offshore needs, coupled with access to expert advice and a comprehensive range, from low to high power.

Sharing

- Support for you to invent vessel-wide drive or grid systems
- Dimensioning and selection tools
- Professional advice in locations around the globe
- Experience and information about existing installations
- Digital EPLAN documentation to reduce your design cost

Inventing

- Modules, components and functionalities to suit any application on board
- Liquid-cooled or back-channel air-cooled drives
- Customer-specific fit using the best software development methods
- Constantly developing new technology capability in vessel construction

Engineering

- Total of nine marine certifications
- Drive modules up to 5.3 MW
- Long lifetime, robust performance and highly efficient equipment
- IP55 and IP66 drives suitable for engine rooms, designed for ambient temperatures from -25 to 55 °C*
- PLC function blocks for easy PLC integration

*derating may apply



Established in 1864, DNV GL is an independent foundation with the objective of safeguarding life, property and the environment.



Since its founding in 1862, the American Bureau of Shipping (ABS), a New York not-for-profit corporation, has been committed to setting standards for safety and excellence as one of the world's leading ship classification societies.



Founded in 1828, Bureau Veritas was one of the first classification societies and a founding member of IACS (International Association of Classification Societies in the world).



KR is a world-leading, technical advisor to the maritime industry. About 70 flag administrations have authorized KR to conduct statutory surveys on their behalf.



Founded in 1956, China Classification Society (CCS) is the only specialized organization of China to provide classification services. CCS aims to provide services for the shipping, shipbuilding, offshore exploitation and related manufacturing industries and marine insurance.



The Rina Group's main activity areas are ship classification, certification and advanced services to industry.



The Lloyd's Register Group is an organization that works to enhance safety and to approve assets and systems at sea, on land and in the air.



A classification society, the Russian Register, was established on 31 December 1913. Now its name is the Russian Maritime Register of Shipping (RS). Since 1969 RS has been a member of the International Association of Classification Societies (IACS).



Class NK (Nippon Kaiji Kyokai) is a Japanese ship classification society dedicated to ensuring the safety of life and property at sea, and the prevention of pollution of the marine environment.

Vessel-wide systems

Sea-going vessels are equipped with complex systems where all functionalities are integrated via an AC and/or DC bus. Therefore when optimizing performance and efficiency, it is never enough to consider individual components in isolation. We help you to assess the total impact and make informed choices on that basis.

In every corner of the ship, from the engine room to the ventilation system, from the cargo deck to the accommodation quarters, we consider the big picture. Then we can give concrete advice on the specific motor controls to optimize performance of the thruster, pump, winch, compressor or fan. No matter what the application, we are there to help you improve efficiency, safety and reliability.

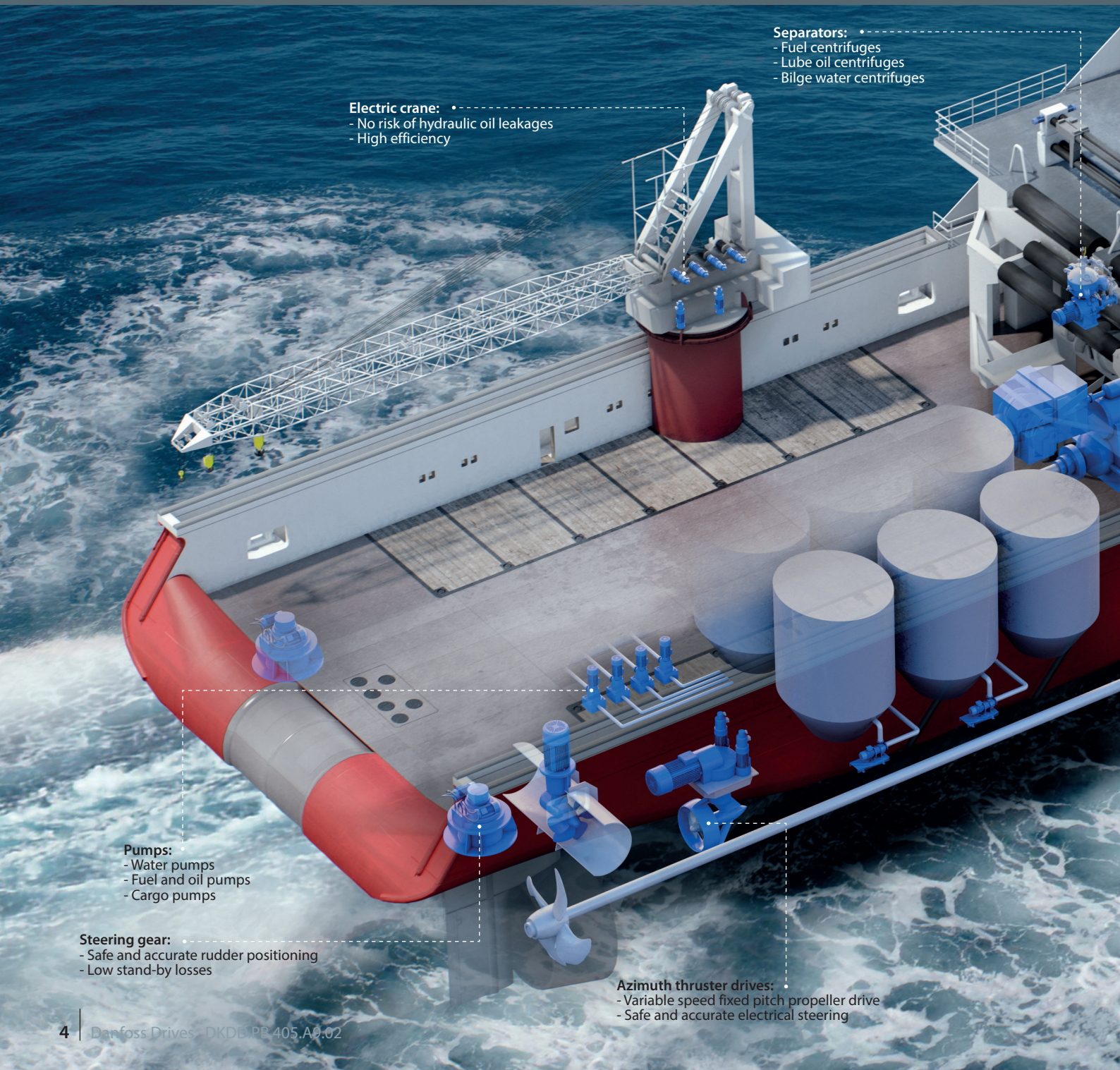
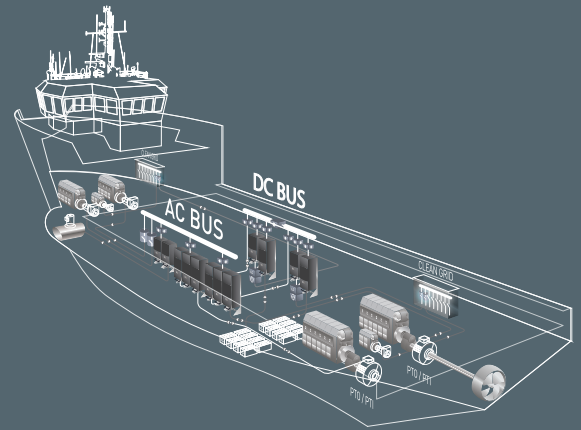

Electric crane:

- No risk of hydraulic oil leakages
- High efficiency

Separators:

- Fuel centrifuges
- Lube oil centrifuges
- Bilge water centrifuges

Pumps:

- Water pumps
- Fuel and oil pumps
- Cargo pumps

Steering gear:

- Safe and accurate rudder positioning
- Low stand-by losses

Azimuth thruster drives:

- Variable speed fixed pitch propeller drive
- Safe and accurate electrical steering

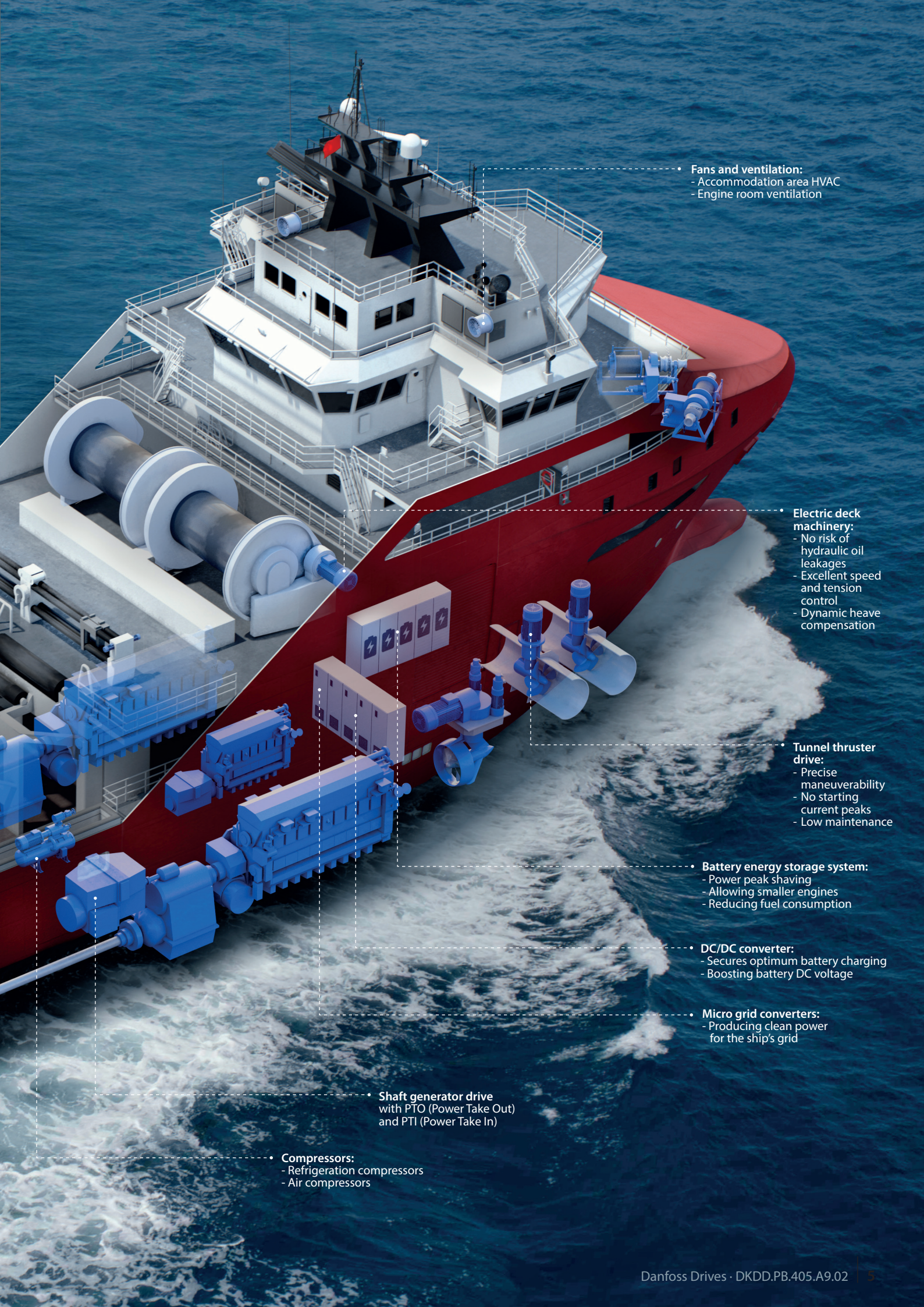

- **Fans and ventilation:**
 - Accommodation area HVAC
 - Engine room ventilation

- **Electric deck machinery:**
 - No risk of hydraulic oil leakages
 - Excellent speed and tension control
 - Dynamic heave compensation

- **Tunnel thruster drive:**
 - Precise maneuverability
 - No starting current peaks
 - Low maintenance

- **Battery energy storage system:**
 - Power peak shaving
 - Allowing smaller engines
 - Reducing fuel consumption

- **DC/DC converter:**
 - Secures optimum battery charging
 - Boosting battery DC voltage

- **Micro grid converters:**
 - Producing clean power for the ship's grid

- **Shaft generator drive with PTO (Power Take Out) and PTI (Power Take In)**

- **Compressors:**
 - Refrigeration compressors
 - Air compressors

VLT® Enclosure size E2h, IP54



VLT® Enclosure size C2, IP55

The modular VLT® technology platform adapted to your requirements

VLT® AutomationDrive, VLT® HVAC Drive and VLT® AQUA Drive are all built on a modular platform allowing for highly customized drives mass produced, tested, and delivered from the factory.

Upgrades and further options dedicated to the marine industry are a matter of plug-and-play. Once you know one, you know them all.

Display options

Danfoss drives' renowned removable Local Control Panel (LCP) has an improved user interface. Choose between 28 built-in languages (including Chinese) or have it customized with your own. Languages can be changed by the user.

Hot pluggable LCP

The LCP can be plugged in or unplugged during operation. Settings are easily transferred via the control panel from one drive to another or from a PC with MCT 10 set-up software.

Integrated manual

The info button makes the printed manual virtually redundant. Users have been involved throughout development to ensure optimum overall functionality of the drive. The

user group has significantly influenced the design and functionality of the LCP.

Optimized motor control

Automatic Motor Adaptation (AMA) is a powerful algorithm that tests and adjusts the drive to the unique traits of your motor, improving overall control and operating efficiency. Enhancements to AMA capability for both induction (IM) and permanent-magnet (PM) motors mean the process can take place in just a few milliseconds without spinning the motor. This enhanced AMA II, running before every start, ensures that the motor parameters are always calibrated to the specific operating conditions, increasing motor control accuracy.

I/O options

The general purpose I/O, relay and

temperature sensor options, expand the flexibility of the drives.

Control terminals

Specially developed removable spring-loaded cage clamps add to reliability and facilitate easy commissioning and service.

24 V supply

A 24 V supply keeps the VLT® drives logically "alive" in situations when the AC power supply is removed.

Real Time Clock

Real Time Clock (RTC) records events with a real time stamp for easier trouble shooting.

RFI filter suitable for IT-grids

Danfoss drives are suitable for IT-grids as standard due to selectable RFI filter switch.

Modular construction and ease of maintenance

All components are easily accessible from the front of the drive, allowing for ease of maintenance and side-by-side mounting of drives. The drives are constructed to a modular design allowing for the easy replacement of modular sub-assemblies.

Wireless Communication Panel

The VLT® Wireless Communication Panel LCP 103 allows programming and monitoring using a smartphone or a tablet via WLAN point-to-point.

Programmable options

The freely-programmable series of VLT® Motion Control Options for user-specific control algorithms and programs allows the integration of PLC programs and the embedded Integrated Motion Controller (IMC)

offers very user friendly positioning functions, for example in lifting applications.

Ruggedized printed circuit boards

Drives for maritime use are ruggedized to withstand vibration levels and the printed circuit boards are coated to withstand salt mist test. The conformal coating complies with the standard IEC 60721-3-3 Class 3C3.

Back-channel cooling

The unique design uses a back-channel to pass cooling-air over heat sinks. This design allows 85-90% of the heat losses to be exhausted directly outside of the enclosure with minimal air passing through the electronics area. This reduces temperature rise and contamination of the electronic components for improved reliability and increased functional life.

Enclosure

The drive meets relevant requirements for all possible installation conditions. Enclosure class IP20/chassis. IP21/NEMA 1, IP54/55/NEMA 12 or IP66/NEMA 4X.

VLT® Motion Control Tool MCT 10

This software provides easy configuration of the drive via PC, and provides a comprehensive overview of all the drives in a system of any size. It adds a new level of flexibility in configuration of the drive, monitoring and troubleshooting.

Motor compatibility

Suitable for nearly all motor types: IM, PM, synchronous reluctance (SynRM), PM assisted SynRM without the need for any special software.

Options and features for ultimate performance

Fieldbus options

Options for serial bus communication are delivered ready to plug and play: PROFINET, PROFIBUS, EtherNet/IP, DeviceNet, CANopen, and more.

ATEX-certified thermistor input

An ATEX-certified thermistor option is available for VLT® AutomationDrive rendering the drive capable of providing sole protection for Ex d and Ex e motors within the installation. The only action required is to connect the PTC thermistors to the drive, for a significant reduction in costs.

Functional safety

VLT® drives can be ordered with Safe Torque Off (STO) functionality

Performance Level (PL) "d" and Category 3, as well as SIL 2. This feature prevents the motor from starting unintentionally. Options for Safe Stop 1 (SS1) Safe Maximum Speed (SMS), Safe Limited Speed (SLS) are available both with and without speed feedback.

Harmonic suppression

Integrated DC chokes ensure very low harmonic disturbance of the power supply according to IEC-1000-3-2. This design eliminates the need for external chokes.

Smart Logic Control

Smart Logic Control is integrated into the VLT® drive. With this feature, you can make the drive react effectively to inputs and events, and often replace PLCs.

PELV

All VLT® drives comply to the PELV (Protective Extra Low Voltage) requirements and are surge-proof in accordance with VDE 0160. Inputs and outputs are electrically isolated.

Up to 150 meters between the drive and the motor

The basic design of VLT® drives allows for up to 150 meters of shielded motor cable – without disturbing other electronic equipment. This allows the VLT® drive to be installed in a central control room.

Type approvals

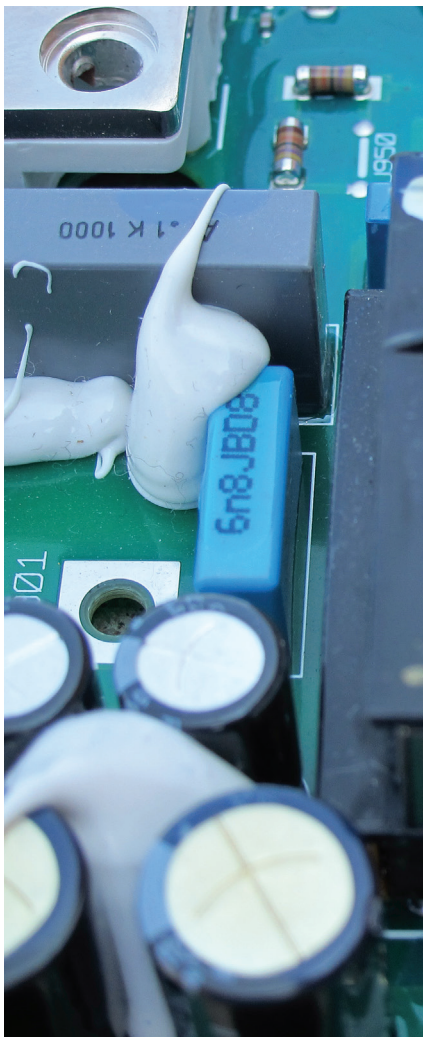

Optimized for reliability and stability

Ruggedized for ultimate maritime protection

In order to reduce the potential negative effects of vibration, the drives have been 'ruggedized'. It is a process that ensures that critical components on the PCB have increased protection, significantly reducing the risk of malfunction while at sea.

The printed circuit boards in the drives are also all coated in accordance with IEC 60721-3-3 class 3C3, providing additional protection against moisture and dust.

Reliable operation at engine room temperatures up to 55 °C

VLT® drives can operate at full load in

engine rooms with 50 °C temperature and 55 °C at reduced power close to, for example, pumps and thrusters.

There is no need for installation in air-conditioned control rooms with long motor cables.

Compact and robust drives up to 800 kW for engine room installations

The redesigned enclosure sizes D and E in protection class IP54 are some of the most compact and robust air-cooled single unit drives available in the market. Offering a power range from 90 kW to 800 kW, they are suitable for installation directly in engine rooms.

Down to 12 months payback time

Drive-controlled sea-water-cooling pumps reduce energy consumption significantly. Usually the payback time is less than one year.

Adapt pump flow rate to actual cooling demand

Ship cooling systems are designed for 100% load at 32 °C water temperature, regardless of the actual water temperature.

Given the fact that not all ships sail in equatorial waters or at maximum speed, the maximum cooling capacity is only rarely needed.

This makes it possible to achieve significant energy savings by allowing pumps to be controlled by a drive that constantly adapts the pump flow rate to the demand at any given time.

Reduce running costs

Once installed, Danfoss drives instantly have a positive impact on running costs. A kWh of electric energy typically costs about € 0.1 at sea. Lowering the average energy consumption of this single application from 75 kW to 14 kW equals 366,000 kWh per year.

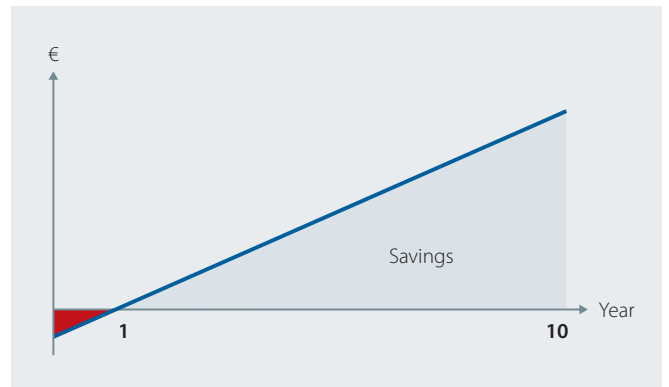
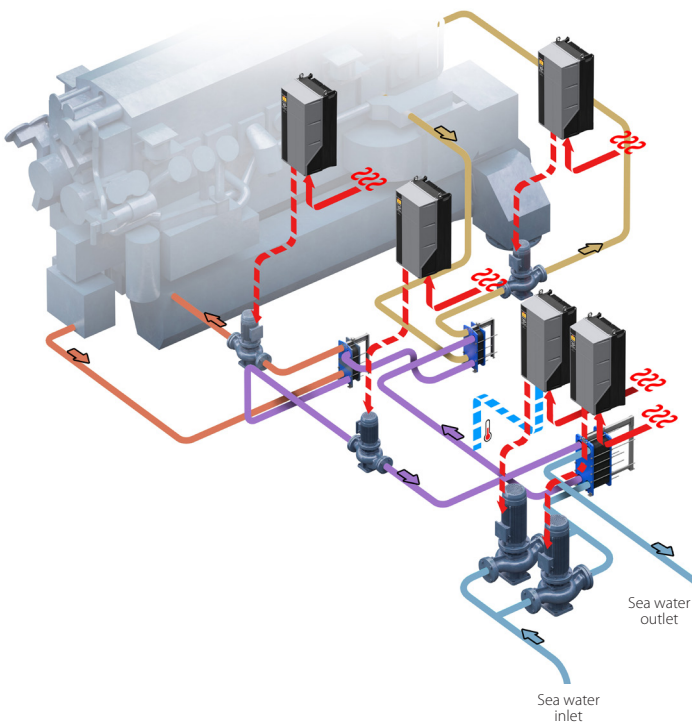

Potential savings – example

Design sea water temperature	32 °C
Average sea water temperature	20 °C
Running hours (year)	6000
Cost per kWh	€ 0.1
Standard system	75 kW = 450,000 kWh per year
Optimized system	14 kW = 84,000 kWh per year
Savings	80%
Annual savings	36,600 €
Installed cost of Danfoss drives system	32,000 €
Payback time	Less than 12 months



VACON® NXP Enclosure size FR10



VACON® 100 Enclosure size MR9

VACON® AC drives deliver precision and clean power

When the most demanding requirements for flexibility, robustness, compactness and service-friendliness apply, turn to the high-precision VACON® NXP range.

Alternatively, for more standard situations, the VACON® 100 range of AC drives exceeds expectations, being easy to use and allowing you to do much more than you would expect from a standard drive.

Quick set-up

Easy commissioning tools ensure a hassle-free set-up whatever the application. Easy diagnostics with help in plain text is provided for each parameter, signal and fault.

- Startup Wizard – for fast setup of basic pump or fan applications
- PID Mini-Wizard – for easy commissioning of internal PID Controller
- Multi-Pump Wizard – for easy commissioning of Multi-Pump system
- Fire Mode Wizard – for easy commissioning of Fire Mode function

Ethernet connectivity

There is no need to purchase additional communication tools, since the integrated Ethernet connectivity allows remote drive access for monitoring, configuring and troubleshooting.

- Ethernet protocols such as PROFINET IO, EtherNet/IP™ and Modbus TCP are available for all NXP drives. New Ethernet protocols are being continuously developed.

User-friendly keypad

The user interface is intuitive to use. You will enjoy the keypad's well-structured menu system that allows for fast commissioning and trouble-free operation.

VACON® NXP family

- Removable panel with plug-in connection
- Graphical and textual keypad with multiple language support
- Text display multi-monitoring function
- Parameter back-up and copy function with the panel's internal memory
- The start-up wizard ensures a hassle-free set up. Choose the language, application type and main parameters during the first power up.

VACON® 100 family

- Graphical and textual keypad with multiple language support
- 9 signals can be monitored at the same time on a single multi-monitor page which is configurable to 9, 6 or 4 signals
- 3-color LED status indication on the control unit
- Trend display for two signals at the same time

Functional safety

Safe Torque Off (STO) prevents the AC drive from generating torque on the motor shaft and prevents unintentional start-ups. The function also corresponds to an uncontrolled stop in accordance with stop category 0, EN 60204-1.

Safe Stop 1 (SS1) initiates the motor deceleration and initiates the STO function after an application-specific time delay. The function also corresponds to a controlled stop in accordance with stop category 1, EN 60204-1.

Integrated STO and SS1 safety options have several advantages over standard safety technology using electromechanical switchgear. For example, separate components and the efforts required to wire and service them are no longer necessary, but the required level of safety at work is maintained.



ATEX-certified thermistor input

Certified and compliant with the European ATEX directive 94/9/EC, the integrated thermistor input is specially designed for the temperature supervision of motors that are placed in areas:

- In which potentially explosive gas, vapor, mist or air mixtures are present
- With combustible dust

If over-heating is detected, the drive immediately stops feeding energy to the motor. As no external components are needed, the cabling is minimized, improving reliability and saving on both space and costs.

Features for VACON® NXP family:

DC cooling fans

VACON® NXP high-performance air-cooled products are equipped with DC fans. This design significantly increases the reliability and lifetime of the fan, also fulfilling the ERP2015 directive on decreasing fan losses. Likewise, the DC-DC supply board component ratings fulfill industrial requirement levels.

Built-in expansion slots

Connect additional I/O, fieldbus and functional safety boards to the VACON® NXP family of drives, using five built-in expansion slots.

Conformal coating

To increase performance and durability, conformal coated circuit boards are standard for VACON® NXP family power modules (FR7 – FR14). The coated boards offer reliable protection against dust and moisture, and extend the lifetime of the drive and critical components.

VACON® DriveSynch

To facilitate design for redundancy when paralleling high-power liquid-cooled drives from the VACON® NXP family, use the VACON® DriveSynch control concept. This control concept allows a motor to be controlled by two to four power units each of 100-1500 kW. VACON® DriveSynch is suitable for controlling single and multi-winding AC motors, and is especially relevant for marine and offshore applications, providing a high degree of redundancy and system safety.

Features for VACON® 100 family:

Drive customizer

Drives in the VACON® 100 family are able to adapt to almost any function requiring I/O and control logic. The drive customizer function features a wide array of logical and numerical function blocks that can combine and extend standard drive functionalities, ensuring specific user requirements are met. The drive customizer does not require any special tools or training, while a fully graphical configuration can be performed using the VACON® Live configuration tool. Configurations can be copied using VACON® Live as part of the normal parameter list.

MAEERSK

MALU
890 312 9
45R1

AQUALIFE

MALU
890 325 7
45R1

MALU
890 316 0
45R1

Marine references

A.P. Moller-Maersk

The A.P. Moller-Maersk Group is a worldwide conglomerate with operations in some 130 countries. The company owns the world's largest container shipping fleet, including the 31 Triple-E class vessels, the largest and most efficient of their kind.

Danfoss Drives is an approved supplier of drives and is on the official maker's list. Our drives have been chosen for a wide range of motor-control applications for the vessels, helping them achieve the A.P. Moller-Maersk Triple-E goals of Economy of scale, Energy efficiency and Environmental improvement.

On the Maersk platform supply vessels and oil tankers that provide quality services to the global oil and gas industry, Danfoss drives provide reliable control of essential equipment. Danfoss drives are also used to control the variable speed of the refrigeration compressor in the thousands of Maersk Container Industry reefers that carry perishable foods from continent to continent in perfect condition.





Ulstein Verft

Ulstein Verft AS is one of the world's foremost suppliers of advanced vessels; primarily anchor handling tug supply vessels, platform supply vessels and specialized and multifunctional vessels.

The shipyard serves as the Ulstein Group's development base for the detailed design and assembly of capital and equipment intensive specialized vessels and is the group's most important expertise base for carrying out projects.



[Read the story](#)



AIDA Cruises

AIDA Cruises is Germany's largest cruise line. The ships of the AIDA fleet are dedicated to the German market and renowned for their young and casual style in combination with a high quality of service. AIDA Cruises is a member of the Carnival Group – the world's largest cruise shipping company.



Viking River Cruises

Viking River Cruises is the world's largest river cruise line, offering cruises along the rivers of Europe, Russia, China, South-East Asia and Egypt.

The vessels' diesel-electric propulsion system is based solely on synchronous and/or asynchronous generators and propulsion motors driven by an AC drive.

The VACON® NXP Common DC Bus solution was the first of its kind to be installed on these vessel types. This

solution is already implemented on board 52 of Viking River Cruises' vessels, making it the world's largest installed base on this vessel type.

VACON® drives and grid converter technologies:

- Reduce fuel consumption and CO₂, NO_x and SO_x emission levels significantly
- Improve maneuverability
- Reduce maintenance costs
- Improve comfort by reducing noise and vibration

 [Read the story](#)



GVB

Amsterdam's waterfront, the IJ River, is one the busiest Dutch waterways connecting the Port of Amsterdam with the North Sea. Every day many passengers cross the IJ River with bicycles, mopeds or on foot, on the 6 free ferry routes which are operated by GVB – the public transport company of Amsterdam.

“We selected a hybrid solution from Holland Shipyard and their electrical propulsion partner, Holland Ship Electric which has very good experience using VACON® NXP drives for their electric propulsion systems.”

Casper van der Werf
Project manager at GVB

 [Read the story](#)



MS Nadorias

On board the MS Nadorias, the huge potential in converting to hybrid is no longer a vision but a reality. A hybrid retrofit has given this inland container carrier a huge 15% saving not only in fuel, but also in CO₂ emission. Since the main diesel engine now runs much less, there is 60% less maintenance cost and higher uptime than for its identical sister ship.

 [Read the story](#)



MS Goblin

Venturing into hybrid propulsion was a bold step for the Vranken family's dry cargo bulk carrier business, which serves the inland waterways of the Rhine. It has paid off fast, delivering rock-bottom operating costs, thanks to an innovative diesel electric propulsion system. This hybrid system replaces the traditional diesel propulsion system used for example on the family's sister ship, the MS Lutin.

 [Read the story](#)



Telstar

Telstar was built by Holland Shipyards and has the unique EDDY Tug design. This makes it easy to drive, easy to maintain and easy to move in any direction. EDDY Tugs are equipped as standard with a hybrid powertrain to minimize operational costs and realize savings. The powertrain consisting of electric, diesel or direct diesel-electric drive was chosen because its low power profile is well-suited to tugboat operating requirements.

 [Read the story](#)



CCB Bergen

Docked oil rigs spend large sums on diesel power generation and normally represent major local CO₂ and NO_x emissions, when parked at Norwegian yards. However vessels visiting Coast Centre Base in Norway now win huge power savings thanks to a shore supply system developed and delivered by SEC and Frekvensomformer.no.

“Shore supply to rigs provides a huge improvement in saved CO₂ and NO_x emissions. We have roughly calculated that a rig will save 10 to 15 tonnes emissions per day. This represents an annual saving of 4,500 tonnes of emissions.”

Sveinung Vethe
CCB Project Manager

 [Read the story](#)

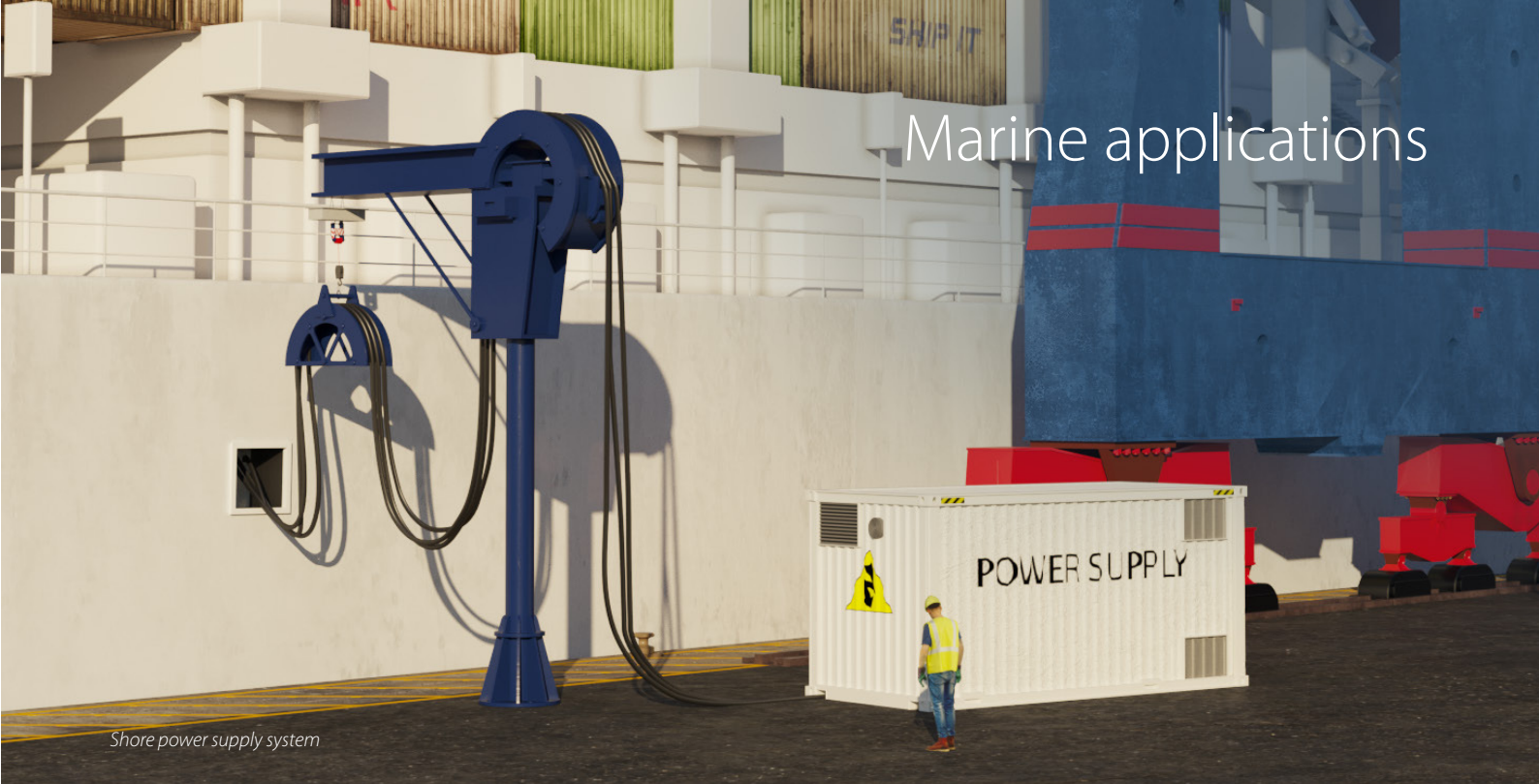

Shore power supply system

Shore supply

Ships consume a large amount of fuel to power their on-board electrical grids during port stays. Burning fuel in sensitive port areas is also a significant source of local air pollution. The obvious solution is to connect the ships to the on-shore electrical grid during berthing but the difference in frequency and voltage is a challenge. Most ocean-going ships have a 60 Hz grid, whereas the power supply in most of the world outside the Americas is 50 Hz.

Shore supply systems convert the 50 Hz shore power to the ship's power system, and synchronize the voltage and frequency to the ship's electrical grid, with a smooth changeover. VACON® micro grid power conversion functionality ensures:

- Timely compliance with ever-more-stringent air quality regulations, for example MARPOL Annex VI Emission Control Areas and European Council Directive 2005/33/EC.
- No contribution to local harbor air pollution. A large proportion of the shore power in the relevant countries is generated from renewable and non-fossil sources.
- Clean power supply, free of harmonic distortion, for protection of the on-board grid.
- Very high system efficiency and low standby losses.

Shore power supply system

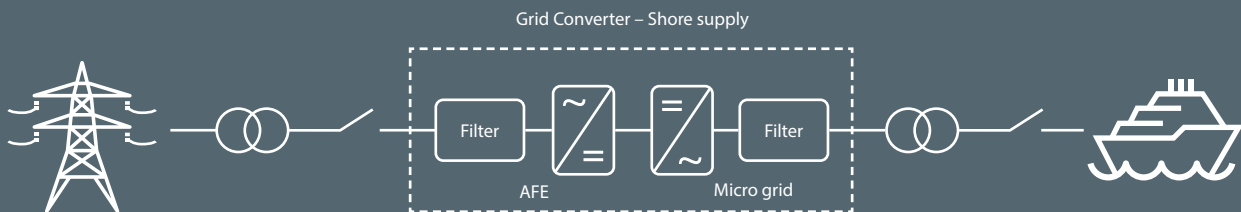

Marine applications

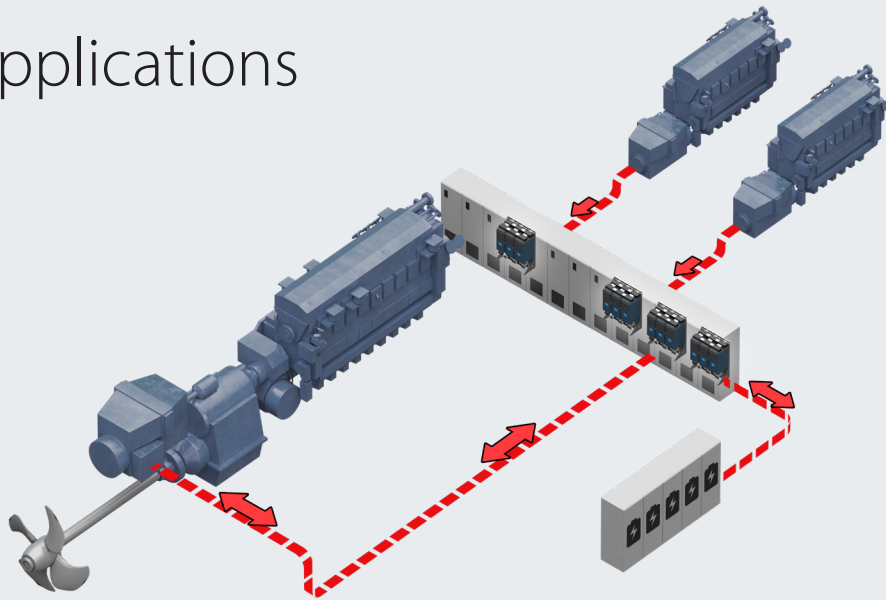

Variable speed shaft generator system with battery – hybridization

Variable speed shaft generator with PTI/PTO and hybrid energy storage

The variable speed shaft generator with power take in/power take out (PTI/PTO) allows the main engines and auxiliary gen-sets to run at their most efficient point. The additional hybrid energy storage battery allows smaller and more efficient engines. Vessels benefit from Danfoss VACON® power conversion technology in these ways:

- The speed of the engines can be optimized to the actual load

demand with up to 30% fuel savings, reduced CO₂ and NO_x emissions.

- During normal operation (PTO) the shaft generator supplies power to the ship grid.
- If an additional propulsion power boost is needed (PTI) the shaft generator receives power from the battery (peak shaving) or from the auxiliary gen-sets.
- In the event of a main engine failure the vessel can travel safely back to port (Take Me to Harbor) using the power from the gen-sets and the battery.

- The common DC bus technology reduces the conversion losses and allows easy integration of the hybrid battery system.
- The micro-grid converter produces a fixed-frequency clean ship grid.
- The DC/DC converter secures optimum battery charging and boosting of the battery voltage.
- Optional shore power supply.

The variable speed shaft generator system and the hybrid battery system can also be retrofitted on existing vessels - typically with an attractive pay back time.

Variable speed shaft generator system with battery – hybridization

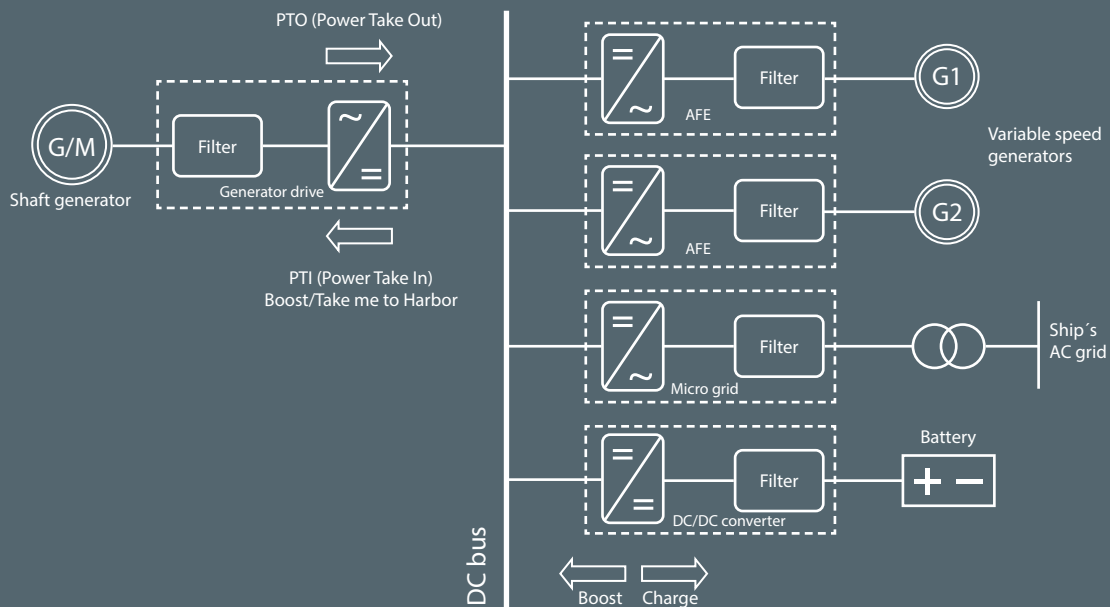

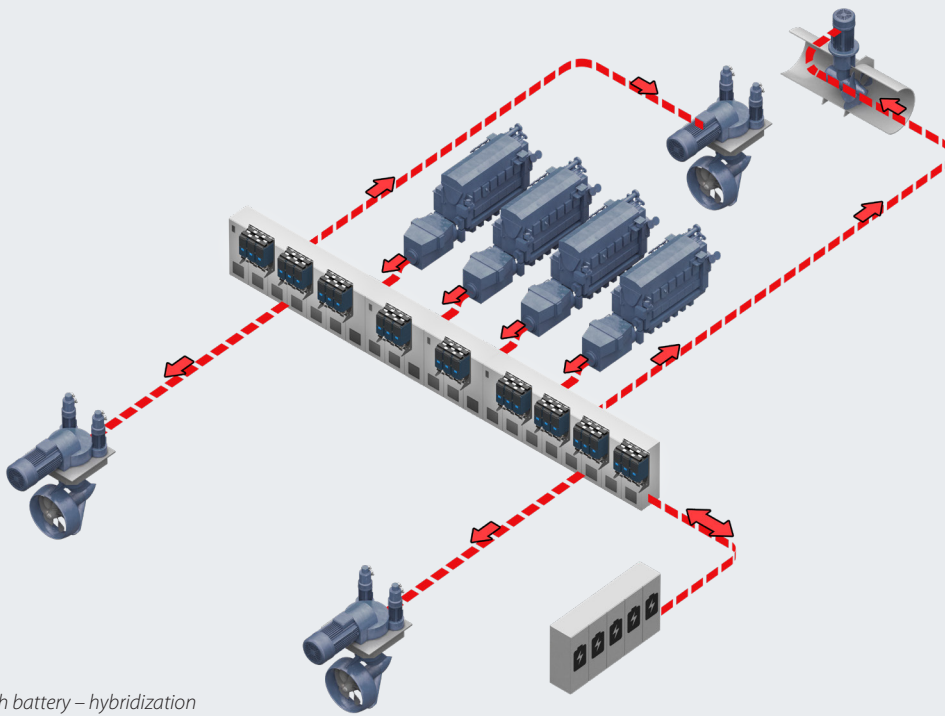

Electric propulsion with battery – hybridization

Electric propulsion with hybrid energy storage

The vessel is fully electric powered using electric azimuth thrusters and tunnel thrusters. The power is generated by variable speed gen-sets. This topology is often used for ferries and offshore vessels. The additional hybrid energy storage system offers peak shaving and allows smaller and more efficient gen-sets. This type of hybridization technology is well suitable for LNG powered vessels. Vessels benefit from Danfoss VACON® power conversion technology in these ways:

- The number of the gen-sets in operation and the speed of the gen-sets can be optimized for fuel savings, reduced CO₂ and NO_x emissions.
- The electrical azimuth thruster provides the ship with a high maneuverability.
- If an additional propulsion power boost is needed the thrusters receive power from the battery (peak shaving) or from the additional auxiliary gen-sets.
- The common DC bus technology reduces the conversion losses and

allows easy integration of the hybrid battery system.

- The micro-grid converter produces a fixed frequency clean ship grid.
- The DC/DC converter secures optimum battery charging and boosting of the battery voltage.
- Optional shore power supply.

Electric propulsion with battery – hybridization

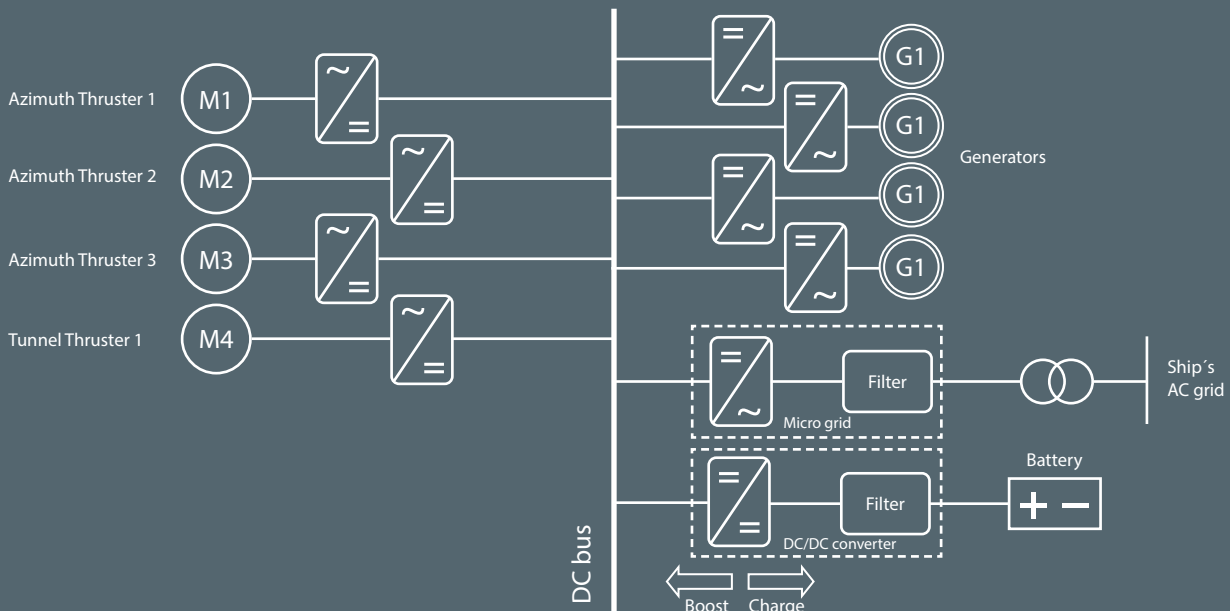

Marine applications

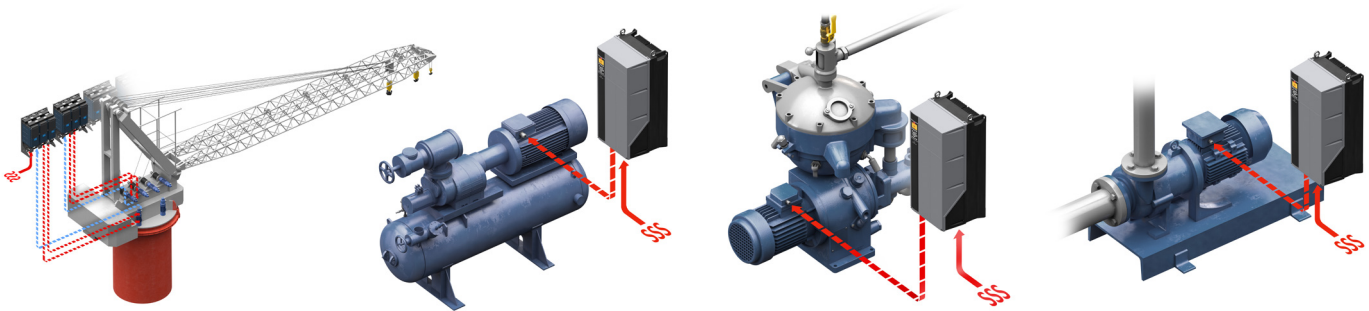

Crane

- Elimination of hydraulic fluid leakages
- Only marginal losses in standby mode
- High efficiency during normal operation
- Environmentally friendly and efficient system

Danfoss drive control of cranes provides higher availability and productivity, compared to traditional hydraulic cranes. By using a drive, owners avoid overheating in the hydraulic oil system and typically benefit from a 15% shorter cycle time, due to faster movements.

Refrigeration compressors

- Improved efficiency
- Built-in compressor control functions
- Improved compressor lifetime

Screw compressors controlled by a Danfoss drive typically use 15% less energy than traditional screw compressors with slide valve control only.

Optimized start/stop cycles reduce wear and tear on the compressor. Drive-controlled reciprocating and scroll compressors have higher COP at part loads. Danfoss drives are particularly suitable for controlling scroll compressors.

Separators

- High operation reliability
- Low maintenance cost
- Safe Maximum Speed (SMS) safety function without external speed sensor

Danfoss drives enable reliable operation of bilge water, fuel conditioning and oil centrifuge separators.

The AC drive ensures smooth acceleration that protects both the gearbox and high-speed bowl bearings.

Control by the AC drive provides tolerance against discharge shock loads. In the event of power failure the drive can catch the spinning separator on the fly, and brake it without needing resistors.

Pumps

- Built-in pump features
- Automatic Energy Optimizer (AEO) saving additional 5-15%
- Pay back down to 12 months using speed controlled pumps

Danfoss drives control the pump to match actual process need, leading to reduced energy consumption. Reducing the speed by 20% reduces the power consumption by 50%.

As well as saving energy, these AC drives also protect the pump in many different marine applications. Pump-dedicated features include built-in PID controllers, dry pump detection, flying start, sleep mode, cascade control, end of curve, and flow compensation.

Typical pump applications: scrubbers, ballast water, bilge water, circulation, cargo, firefighting, feeding pumps, lubrication, and sea water pumps.

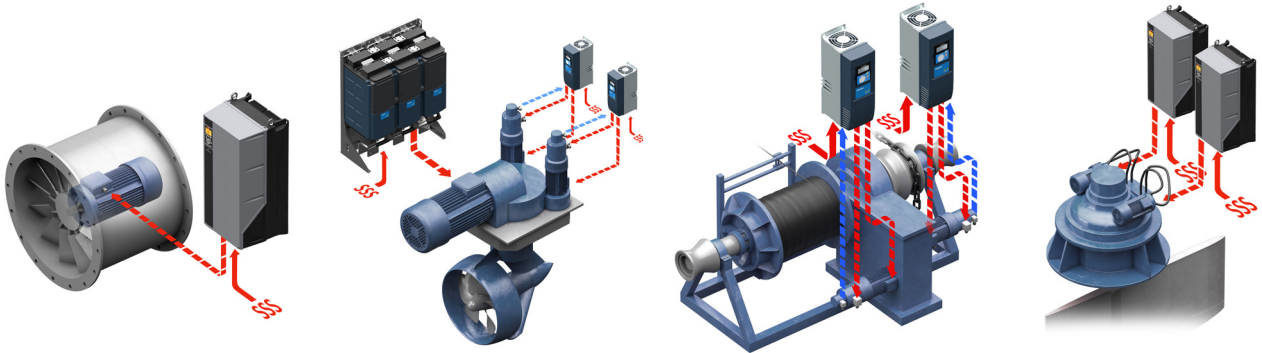

Fan and ventilation

- Typically 30-50% energy savings
- Reduced acoustic noise
- Fire mode improves safety in HVAC systems

Load-dependent capacity control and Automatic Energy Optimization save energy and reduce audible noise in ventilation systems in engine rooms, galleys, thruster rooms, cargo, pump rooms, defroster systems, dehumidifiers and cargo-room refrigeration. In the event of fire, the fans will maintain smoke extraction under all conditions running in fire mode.

Thrusters

- Safe and precise maneuverability
- 20-30% energy savings compared to variable pitch thrusters
- Low maintenance cost

Danfoss drives' high torque capabilities and their fast and accurate performance provide precise maneuverability in all seas.

Danfoss drive-controlled variable speed propellers with fixed pitch are typically 20-30% more energy efficient than fixed-speed variable-pitch propellers – which waste approximately 20% of the power at zero thrust.

Frequency-controlled variable-speed propellers use 50% less energy than hydraulic variable-speed propellers.

Electrically-steered thrusters, gives more accurate control and responds more quickly than a hydraulic steering system. A minimum of two parallel motors and drives are always in use. If one combination stops, the steering system continues to operate.

Winch

- No risk of hydraulic fluid leakages
- Low energy consumption and no stand-by losses
- Low acoustic noise level

Compared to hydraulic systems, electrical motors controlled by a Danfoss drive provide substantial energy savings, low noise operation and no risk of hydraulic oil leaks. Drives enable excellent speed and tension control and load sharing with several motors driving the same winch.

Advanced mechanical brake control eases stress on both gear and brake, while automatic DC hold preheating keeps the motor dry in standby mode. Robust open-loop control eliminates the need for fragile encoders in open deck environments. To enhance reliability, use highly dynamic active heave compensation functionality, which actively maintain a steady position of the load.

Steering gear

- Fast and precise rudder positioning
- Extremely safe due to live back-up system
- More than 70% energy savings compared to fixed speed hydraulic pump system

With variable-speed control, it is possible to achieve accurate rudder positioning, enabling a precise analog control system. In rotary-vane steering gear with reversible hydraulic pumps, use a Danfoss drive to change speed and direction, saving energy by only running when the vessel is changing course.

AC drives for marine applications

VLT® drives have proved their worth in demanding applications all over the world, for decades. They also offer distinct advantages in marine applications.

VLT® AutomationDrive

The VLT® AutomationDrive FC 302 is a single drive concept that covers the entire range of marine applications. Designed to provide control, stability and efficiency, the drive ensures that applications such as thrusters, winches, hoists and steering gear function reliably in all conditions.

Featuring high torque capabilities with overload as high as 160%, the VLT® AutomationDrive always takes firm grip on its application. Often, the strength of the drive will enable owners to eliminate other components.

VLT® HVAC Drive

Reduce energy consumption and increase energy efficiency in HVAC applications. VLT® HVAC Drive FC 102 provides precise and intelligent control of on-board pumps, fans and compressors.

All functions are built into the drive upon delivery and save space while enabling easy installation. The integrated Automatic Energy Optimizer function can save an additional 5-15% more energy through advanced control of the application in question. Due to the fact that the drive supports a wide range of HVAC protocols, the VLT® HVAC Drive reduces the need for extra gateway solutions.

VLT® AQUA Drive

Optimized for on-board, water and wastewater applications the VLT® AQUA Drive FC 202 provides optimized, energy-saving operation of pumps and fans.

Featuring dedicated pump features, such as auto-tuning of PI controllers, the drive monitors and learns how the system reacts to corrections made by the drive to quickly achieve precise and stable operation.



For more information please see:

[VLT® AutomationDrive](#), [VLT® HVAC Drive](#) and [VLT® AQUA Drive](#) selection guides.



Products																								
Type code power	VLT® HVAC Drive FC 102		VLT® AQUA Drive FC 202		Type code power	VLT® Automation Drive FC 302		T2 200 – 240 V					T4 380 – 480 V T5 380 – 500 V					T7 525 – 690 V						
	kW		kW			kW		IP20	IP21	IP54	IP55	IP66	IP20	IP21	IP54	IP55	IP66	IP20	IP21	IP54	IP55	IP66		
	NO ¹		NO ¹	HO ²		NO ¹	HO ²																	
PK25			0.25		PK25		0.25																	
PK37			0.37		PK37		0.37																	
PK55			0.55		PK55		0.55																	
PK75			0.75		PK75		0.75	A2	A2															
P1K1	1.1	1.1	1.1		P1K1		1.1				A4/A5	A4/A5												
P1K5	1.5	1.5	1.5		P1K5		1.5						A2	A2										
P2K2	2.2	2.2	2.2		P2K2		2.2								A4/A5	A4/A5								
P3K0	3	3	3		P3K0		3																	
P3K7	3.7	3.7	3.7		P3K7		3.7	A3	A3						A5	A5						A3	A3	
P4K0	4	4	4		P4K0		4						A2	A2										
P5K5	5.5	5.5	3.7																					
P7K5	7.5	7.5	5.5		P5K5	7.5	5.5	B3	B1								A3	A3						
P11K	11	11	7.5		P7K5	11	7.5																	
P15K	15	15	11		P11K	15	11	B4	B2															
P18K	18	18.5	15		P15K	18.5	15																	
P22K	22	22	18.5		P18K	22	18.5																	
P30K	30	30	22		P22K	30	22	C3	C1															
P37K	37	37	30		P30K	37	30																	
P45K	45	45	37		P37K	45	37																	
P55K	55	55	45		P45K	55	45																	
P75K/N75K*	75	75	55		P55K/N55K*	75	55																	
P90K/N90K*	90	90	75		P75K/N75K*	90	75																	
N110	110	110	90		N90	110	90																	
N132	132	132	110		N110	132	110						D3h	D1h/D5h/D6h	D1h/D5h/D6h									
N160	160	160	132		N132	160	132																	
N200	200	200	160		N160	200	160																	
N250	250	250	200		N200	250	200						D4h	D2h/D5h/D6h	D2h/D7h/D8h									
N315	315	315	250		N250	315	250																	
N400*	400	400	315		N315*	400	315																	
N355	355	355	315		N315	355	315																	
N400	400	400	355		N355	400	355																	
N450	450	450	400		N400	450	400																	
N450*	450	450	355		N355*	450	355																	
N500*	500	500	400		N400*	500	400																	
N500	500	500	450		N450	500	450																	
N560	560	560	500		N500	560	500																	
N630/P630**	630	630	560		N560/P560**	630	560																	
N710/P710**	710	710	630		N630/P630**	710	630																	
N800/P800**	800	800	710		N710/P710**	800	710																	
P1M0**	1000	1000	900		P800**	1000	800																	
P900	900	900	800		P800*	900	800																	
P1M0*	1000	1000	900		P900	1000	900																	
P1M2	1200	1200	1000		P1M0	1200	1000																	
P1M4	1400	1400	1200		P1M2	1400	1200																	

¹ Normal overload
² High overload
* @ 690 V
** @ 400 V

Note:
T4/T5: All ratings @ 400 V
T7: All ratings @ 690 V

- IP20/Chassis
- IP21/Type 1
- IP21 with upgrade kit
- IP54/Type 12
- IP55/Type 12
- IP66/NEMA 4X



Dimensions [mm]

	A2	A3	A4	A5	B1	B2	B3	B4	C1	C2	C3	C4	D1h	D2h	D3h	D4h	E1h	E2h	E3h	E4h	F1	F2	F3	F4	
H	268	390	420	480	650	399	520	680	770	550	660	901	1107	909	1122	2043	2043	1578	1578	2280	2280	2280	2280		
W	90	130	200	242		165	230	308	370	308	370	325	420	250	350	600	700	507	607	1400	1804	1997	2401		
D	205	175	200	260		249	242	310	335	333		378		375		510	510	482	482	607	607	607	607		
H+	375						475	670					755	950											
W+	90	130					165	255			329	391													

Note: H and W dimensions are with back-plate. H+ and W+ are with IP upgrade kit. D-frame dimensions are without options (extended versions).

AC drives for marine applications

VACON® 100 INDUSTRIAL

The VACON® 100 INDUSTRIAL serves a wide range of industrial applications. It is easy to integrate into systems and easy to adapt to different needs.

One drive - many applications

VACON® 100 INDUSTRIAL is full of smart features dedicated to a wide range of constant power/torque applications. It integrates easily into all major control systems and adapts quickly to different needs.

Easy integration

Integrated RS485 and Ethernet interfaces support all major industrial protocols. Save on extra cards – and use the same drive no matter what the protocol required.

Easy adaptation

Built-in PLC functionality enables you to create new functionality in the drive. The VACON® CUSTOMIZER facilitates smaller logic adaptations for special needs or retrofit situations.

High availability

Enjoy enhanced reliability due to long-life DC link capacitors which are electrolytic-free, using plastic foil technology.

Performance is ensured even after many years of storage.

VACON® 100 FLOW

Dedicated functionality helps you to improve flow control in industrial applications.

Dedicated flow control

In addition to general convenient usability and systems support functions, VACON® 100 FLOW provides specific flow-control functions to enhance pump and fan performance and protect pipes and equipment.

Connectivity included

No extra parts are required for connection to the leading industrial fieldbus systems, thanks to on-board RS485 and Ethernet interfaces as standard.

Run high-efficiency motors

Select the most efficient motor for your task, with the ability to run the new high-efficiency motor technologies, such as permanent magnet and synchronous reluctance motors.



For more information please see:

[VACON® 100 INDUSTRIAL and VACON® 100 FLOW selection guide.](#)



AC drive type	Low overload VACON® FLOW, VACON® INDUSTRIAL	High overload VACON® INDUSTRIAL	Enclosure size
	Motor shaft power	Motor shaft power	
	230 V 40 °C [kW]	230 V 50 °C [kW]	
Mains voltage 208-240 V, 50/60 Hz			
VACON 0100-3L-0003-2-xxxx	0.55	0.37	MR4
VACON 0100-3L-0004-2-xxxx	0.75	0.55	
VACON 0100-3L-0007-2-xxxx	1.1	0.75	
VACON 0100-3L-0008-2-xxxx	1.5	1.1	
VACON 0100-3L-0011-2-xxxx	2.2	1.5	
VACON 0100-3L-0012-2-xxxx	3	2.2	MR5
VACON 0100-3L-0018-2-xxxx	4	3	
VACON 0100-3L-0024-2-xxxx	5.5	4	MR6
VACON 0100-3L-0031-2-xxxx	7.5	5.5	
VACON 0100-3L-0048-2-xxxx	11	7.5	MR7
VACON 0100-3L-0062-2-xxxx	15	11	
VACON 0100-3L-0075-2-xxxx	18.5	15	MR8
VACON 0100-3L-0088-2-xxxx	22	18.5	
VACON 0100-3L-0105-2-xxxx	30	22	MR9
VACON 0100-3L-0140-2-xxxx	37	30	
VACON 0100-3L-0170-2-xxxx	45	37	MR9
VACON 0100-3L-0205-2-xxxx	55	45	
VACON 0100-3L-0261-2-xxxx	75	55	MR9
VACON 0100-3L-0310-2-xxxx	90	75	

AC drive type	Low overload VACON® FLOW, VACON® INDUSTRIAL	High overload VACON® INDUSTRIAL	Enclosure size
	Motor shaft power	Motor shaft power	
	400 V 40 °C [kW]	400 V 50 °C [kW]	
Mains voltage 380-500 V, 50/60 Hz			
VACON 0100-3L-0003-5-xxxx	1.1	0.75	MR4
VACON 0100-3L-0004-5-xxxx	1.5	1.1	
VACON 0100-3L-0005-5-xxxx	2.2	1.5	
VACON 0100-3L-0008-5-xxxx	3	2.2	
VACON 0100-3L-0009-5-xxxx	4	3	
VACON 0100-3L-0012-5-xxxx	5.5	4	MR5
VACON 0100-3L-0016-5-xxxx	7.5	5.5	
VACON 0100-3L-0023-5-xxxx	11	7.5	MR6
VACON 0100-3L-0031-5-xxxx	15	11	
VACON 0100-3L-0038-5-xxxx	18.5	15	MR7
VACON 0100-3L-0046-5-xxxx	22	18.5	
VACON 0100-3L-0061-5-xxxx	30	22	MR8
VACON 0100-3L-0072-5-xxxx	37	30	
VACON 0100-3L-0087-5-xxxx	45	37	MR9
VACON 0100-3L-0105-5-xxxx	55	45	
VACON 0100-3L-0140-5-xxxx	75	55	MR10
VACON 0100-3L-0170-5-xxxx	90	75	
VACON 0100-3L-0205-5-xxxx	110	90	MR12
VACON 0100-3L-0261-5-xxxx	132	110	
VACON 0100-3L-0310-5-xxxx	160	132	MR12
VACON 0100-3L-0385-5-xxxx	200	160	
VACON 0100-3L-0460-5-xxxx	250	200	MR12
VACON 0100-3L-0520-5-xxxx	250	250	
VACON 0100-3L-0590-5-xxxx	315	250	MR12
VACON 0100-3L-0650-5-xxxx	355	315	
VACON 0100-3L-0730-5-xxxx	400	355	MR12
VACON 0100-3L-0820-5-xxxx	450	400	
VACON 0100-3L-0920-5-xxxx	500	450	MR12
VACON 0100-3L-1040-5-xxxx	560	500	
VACON 0100-3L-1180-5-xxxx	630	500	MR12

AC drive type	Low overload VACON® FLOW, VACON® INDUSTRIAL	High overload VACON® INDUSTRIAL	Enclosure size
	Motor shaft power	Motor shaft power	
	690 V 50 °C [kW]	690 V 50 °C [kW]	
Mains voltage 525-690 V, 50/60 Hz			
VACON 0100-3L-0007-7-xxxx	5.5	4	MR6
VACON 0100-3L-0010-7-xxxx	7.5	5.5	
VACON 0100-3L-0013-7-xxxx	11	7.5	
VACON 0100-3L-0018-7-xxxx	15	11	
VACON 0100-3L-0022-7-xxxx	18.5	15	
VACON 0100-3L-0027-7-xxxx	22	18.5	MR7
VACON 0100-3L-0034-7-xxxx	30	22	
VACON 0100-3L-0041-7-xxxx	37	30	MR8
VACON 0100-3L-0052-7-xxxx	45	37	
VACON 0100-3L-0062-7-xxxx	55	45	MR9
VACON 0100-3L-0080-7-xxxx	75	55	
VACON 0100-3L-0100-7-xxxx	90	75	MR10
VACON 0100-3L-0125-7-xxxx	110	90	
VACON 0100-3L-0144-7-xxxx	132	110	MR12
VACON 0100-3L-0170-7-xxxx	160	132	
VACON 0100-3L-0208-7-xxxx	200	160	MR12
VACON 0100-3L-0261-7-xxxx	250	200	
VACON 0100-3L-0325-7-xxxx	315	250	MR12
VACON 0100-3L-0385-7-xxxx	355	315	
VACON 0100-3L-0416-7-xxxx	400	355	MR12
VACON 0100-3L-0460-7-xxxx	450	400	
VACON 0100-3L-0520-7-xxxx	500	450	MR12
VACON 0100-3L-0590-7-xxxx	560	500	
VACON 0100-3L-0650-7-xxxx	630	560	MR12
VACON 0100-3L-0750-7-xxxx	710	630	
VACON 0100-3L-0820-7-xxxx	800	630	MR12



Dimensions

Enclosure size	IP21 and IP54	IP00	Enclosed drive IP21 and IP54
	W x H x D	W x H x D	W x H x D
	mm	mm	mm
MR4	128 x 328 x 190		
MR5	144 x 419 x 214		
MR6	195 x 557 x 229		
MR7	237 x 645 x 259		
MR8	290 x 996 x 343	290 x 794 x 343	406 x 2100 x 600
MR9	480 x 1150 x 365	480 x 840.5 x 365	606 x 2100 x 600
MR10		506 x 980 x 525*	606 x 2100 x 600
MR12		2 x (506 x 980 x 525)*	1212 x 2100 x 600

* Without options module



For more information please see:
VACON® 100 INDUSTRIAL and VACON® 100 FLOW selection guide.

AC drives for marine applications

VACON® NXP Air Cooled

With a wide power range, the VACON® NXP Air Cooled drive is the ideal drive for enhanced performance for marine and offshore applications.

Top performance

With VACON® NXP control flexibility, you obtain maximum motor control performance combined with easy usability.

Fully configurable I/O and fieldbuses cater for any connectivity need. Fast drive-to-drive communication gives you the flexibility of load sharing and paralleling of power units.

High-power units are available in 6-pulse and 12-pulse versions.

Extremely flexible

Adapt the drive to many diverse usage requirements by loading the VACON® application software that best suits your needs. Built-in PLC functionality enables you to create new functionality in the drive.

VACON® NXC Air Cooled Enclosed

The VACON® NXC Air Cooled Enclosed Drive comprises a VACON® NXP drive which is cabinet-mounted, factory-tested and certified.

Easy to configure

Choose between a wide range of control and power options when ordering.

Select 6-pulse or 12-pulse supply compatibility as required. System integrators and panel builders will benefit from easy integration ability, pre-tested cabinet solutions and many control benefits.

Safety first

Ensure safe and easy installation by choosing this enclosed drive, which is delivered pre-mounted in its own cabinet, fully factory-tested and certified. It is internally protected against unintentional human contact.

Access to the control equipment is easy and safe, due to the dedicated control compartment located at the front of the cabinet.



For more information please see:

[VACON® NXP and VACON® NXC selection guide.](#)



VACON® NXP wall-mounted

AC drive type	Motor shaft power		Enclosure size	
	230 V / 400 V / 690 V			
	10% overload P [kW]	50% overload P [kW]		
Mains voltage 208-240 V, 50/60 Hz, 3[~]				
NXP 0003 2 A 2 H 1 S S S	0.55	0.37	FR4	
NXP 0004 2 A 2 H 1 S S S	0.75	0.55		
NXP 0007 2 A 2 H 1 S S S	1.1	0.75		
NXP 0008 2 A 2 H 1 S S S	1.5	1.1		
NXP 0011 2 A 2 H 1 S S S	2.2	1.5		
NXP 0012 2 A 2 H 1 S S S	3	2.2	FR5	
NXP 0017 2 A 2 H 1 S S S	4	3		
NXP 0025 2 A 2 H 1 S S S	5.5	4		
NXP 0031 2 A 2 H 1 S S S	7.5	5.5		
NXP 0048 2 A 2 H 1 S S S	11	7.5		
NXP 0061 2 A 2 H 1 S S S	15	11	FR6	
NXP 0075 2 A 2 H 0 S S S	22	15	FR7	
NXP 0088 2 A 2 H 0 S S S	22	22		
NXP 0114 2 A 2 H 0 S S S	30	22		
NXP 0140 2 A 2 H 0 S S S	37	30		
NXP 0170 2 A 2 H 0 S S S	45	37		
NXP 0205 2 A 2 H 0 S S S	55	45	FR8	
NXP 0261 2 A 2 H 0 S S F	75	55		
NXP 0300 2 A 2 H 0 S S F	90	75		
Mains voltage 380-500 V, 50/60 Hz, 3[~]				
NXP 0003 5 A 2 H 1 S S S	1.1	0.75		FR4
NXP 0004 5 A 2 H 1 S S S	1.5	1.1		
NXP 0005 5 A 2 H 1 S S S	2.2	1.5		
NXP 0007 5 A 2 H 1 S S S	3	2.2		
NXP 0009 5 A 2 H 1 S S S	4	3		
NXP 0012 5 A 2 H 1 S S S	5.5	4	FR5	
NXP 0016 5 A 2 H 1 S S S	7.5	5.5		
NXP 0022 5 A 2 H 1 S S S	11	7.5		
NXP 0031 5 A 2 H 1 S S S	15	11		
NXP 0038 5 A 2 H 1 S S S	18.5	15		
NXP 0045 5 A 2 H 1 S S S	22	18.5	FR6	
NXP 0061 5 A 2 H 1 S S S	30	22	FR7	
NXP 0072 5 A 2 H 0 S S S	37	30		
NXP 0087 5 A 2 H 0 S S S	45	37		
NXP 0105 5 A 2 H 0 S S S	55	45		
NXP 0140 5 A 2 H 0 S S S	75	55		
NXP 0168 5 A 2 H 0 S S S	90	75	FR8	
NXP 0205 5 A 2 H 0 S S S	110	90	FR9	
NXP 0261 5 A 2 H 0 S S F	132	110		
NXP 0300 5 A 2 H 0 S S F	160	132		
Mains voltage 525-690 V, 50/60 Hz, 3[~]				
NXP 0004 6 A 2 L 0 S S S	3	2.2	FR6	
NXP 0005 6 A 2 L 0 S S S	4	3		
NXP 0007 6 A 2 L 0 S S S	5.5	4		
NXP 0010 6 A 2 L 0 S S S	7.5	5.5		
NXP 0013 6 A 2 L 0 S S S	11	7.5		
NXP 0018 6 A 2 L 0 S S S	15	11	FR7	
NXP 0022 6 A 2 L 0 S S S	18.5	15		
NXP 0027 6 A 2 L 0 S S S	22	18.5		
NXP 0034 6 A 2 L 0 S S S	30	22		
NXP 0041 6 A 2 L 0 S S S	37.5	30		
NXP 0052 6 A 2 L 0 S S S	45	37.5	FR8	
NXP 0062 6 A 2 L 0 S S S	55	45	FR9	
NXP 0080 6 A 2 L 0 S S S	75	55		
NXP 0100 6 A 2 L 0 S S S	90	75		
NXP 0125 6 A 2 L 0 S S F	110	90		
NXP 0144 6 A 2 L 0 S S F	132	110		
NXP 0170 6 A 2 L 0 S S F	160	132		
NXP 0208 6 A 2 L 0 S S F	200	160		

Enclosure size	Height	Width	Depth
	mm	mm	mm
FR4	327	128	190
FR5	419	144	214
FR6	558	195	237
FR7	630	237	257
FR8	758	291	344
FR9	1150	480	362
FR10	2018	595	602
FR11	2018	794	602
FR12	2275	1206	605
FR13	2275	1406	605
FR14	2275	2406 2806	605

VACON® NXP drive module

AC drive type	Motor shaft power		Enclosure size	
	400 V / 690 V			
	10% overload P [kW]	50% overload P [kW]		
Mains voltage 380-500 V, 50/60 Hz, 3[~]				
NXP 0385 5 A 0 N 0 S S A	200	160	FR10	
NXP 0460 5 A 0 N 0 S S A	250	200		
NXP 0520 5 A 0 N 0 S S A	250	250		
NXP 0590 5 A 0 N 0 S S A	315	250		
NXP 0650 5 A 0 N 0 S S A	355	315		
NXP 0730 5 A 0 N 0 S S A	400	355	FR11	
NXP 0820 5 A 0 N 0 S S A	450	400		
NXP 0920 5 A 0 N 0 S S A	500	450		
NXP 1030 5 A 0 N 0 S S A	560	500		
NXP 1150 5 A 0 N 0 S S F	630	560		
NXP 1300 5 A 0 N 0 S S F ¹⁾	710	630	FR12	
NXP 1450 5 A 0 N 0 S S F ¹⁾	800	710		
NXP 1770 5 A 0 N 0 S S F	1000	900		
NXP 2150 5 A 0 N 0 S S F	1200	1100		
Mains voltage 525-690 V, 50/60 Hz, 3[~]				
NXP 261 6 A 0 N 0 S S A	250	200	FR10	
NXP 325 6 A 0 N 0 S S A	315	250		
NXP 385 6 A 0 N 0 S S A	355	315		
NXP 416 6 A 0 N 0 S S A*	400	315		
NXP 460 6 A 0 N 0 S S A	450	355		
NXP 502 6 A 0 N 0 S S A	500	450	FR11	
NXP 590 6 A 0 N 0 S S A*	560	500		
NXP 650 6 A 0 N 0 S S A	630	560		
NXP 750 6 A 0 N 0 S S A	710	630		
NXP 820 6 A 0 N 0 S S A*	800	630		
NXP 920 6 A 0 N 0 S S F	900	800	FR12	
NXP 1030 6 A 0 N 0 S S F	1000	900		
NXP 1180 6 A 0 N 0 S S F*	1150	1000		
NXP 1500 6 A 0 N 0 S S F ²⁾	1500	1300		
NXP 1900 6 A 0 N 0 S S F	1800	1500		
NXP 2250 6 A 0 N 0 S S F*	2000	1800	FR13	
Mains voltage 525-690 V, 50/60 Hz, 3[~]				
NXP 261 6 A 2 L 0 S S A	250	200	FR10	
NXP 325 6 A 2 L 0 S S A	315	250		
NXP 385 6 A 2 L 0 S S A	355	315		
NXP 416 6 A 2 L 0 S S A*	400	315		
NXP 460 6 A 2 L 0 S S A	450	355		
NXP 502 6 A 2 L 0 S S A	500	450	FR11	
NXP 590 6 A 2 L 0 S S A*	560	500		
Mains voltage 525-690 V, 50/60 Hz, 3[~]				
NXP 261 6 A 2 L 0 S S A	250	200		FR10
NXP 325 6 A 2 L 0 S S A	315	250		
NXP 385 6 A 2 L 0 S S A	355	315		
NXP 416 6 A 2 L 0 S S A*	400	315		
NXP 460 6 A 2 L 0 S S A	450	355		
NXP 502 6 A 2 L 0 S S A	500	450	FR11	
NXP 590 6 A 2 L 0 S S A*	560	500		

* Max. ambient temperature of +35°C
 1) 12-pulse units, 4 x (497 x 449 x 249/130)
 2) 12-pulse units, 2 x (354 x 319 x 230/53 kg)

VACON® NXP standalone

AC drive type	Motor shaft power		Enclosure size	
	400 V / 690 V			
	10% overload P [kW]	50% overload P [kW]		
Mains voltage 380-500 V, 50/60 Hz, 3[~]				
NXP 0385 5 A 2 L 0 S S A	200	160	FR10	
NXP 0460 5 A 2 L 0 S S A	250	200		
NXP 0520 5 A 2 L 0 S S A	250	250		
NXP 0590 5 A 2 L 0 S S A	315	250		
NXP 0650 5 A 2 L 0 S S A	355	315		
NXP 0730 5 A 2 L 0 S S A	400	355	FR11	
Mains voltage 525-690 V, 50/60 Hz, 3[~]				
NXP 261 6 A 2 L 0 S S A	250	200		FR10
NXP 325 6 A 2 L 0 S S A	315	250		
NXP 385 6 A 2 L 0 S S A	355	315		
NXP 416 6 A 2 L 0 S S A*	400	315		
NXP 460 6 A 2 L 0 S S A	450	355		
NXP 502 6 A 2 L 0 S S A	500	450	FR11	
NXP 590 6 A 2 L 0 S S A*	560	500		

* Max. ambient temperature of +35°C



 **For more information please see:**
 VACON® NXP and VACON® NXC selection guide.

AC drives for marine applications

VACON® NXC Low Harmonic

With a built-in active filter, the VACON® NXC Low Harmonic drive is the ideal choice for the most demanding power quality requirements.

Harmonics compliance

There is no need for additional harmonics mitigation, since the drive already complies with regulatory standards and requirements for power quality in electrical networks.

Save infrastructure costs

The low total current distortion (THDi) of the supply power contributes to a considerably lower supply current. As a result, the dimensions of fuses, supply cables and supply transformers can be kept optimal. And, as there's no need to oversize cables and transformers, you can achieve up to 30% savings on network infrastructure costs in both new and retrofit projects.

VACON® NXP Liquid Cooled

Active front-end (AFE)

The AFE unit is ideal for a wide range of applications where there is a need for energy regeneration.

Regenerative braking

The most significant benefits of an AFE unit come when the drive is used with applications with a braking need – such as cranes. The braking energy can be fed back to the mains to be effectively used elsewhere.

Clean power

Enjoy the benefits of a clean power supply, with virtually harmonics-free input current. AFE technology reduces the THDi to less than 5%.

Non-regenerative front-end (NFE)

The NFE unit is a unidirectional (motoring) power converter for the front-end of a common DC bus drive line-up. A dedicated external choke is used at the input.

Multi-pulse option for lower harmonics

This unit is suitable as a 6- or 12-pulse rectifying device when no regeneration to the mains is required. Connect NFE units in parallel to increase power without any drive-to-drive commutation between the units.



VACON® NXC Low Harmonic

AC drive type	Motor shaft power		Enclosure size
	400V/690V		
	10% overload P [kW]	50% overload P [kW]	
Mains voltage 380-500 V, 50/60 Hz			
NXC 0261 5 A 2 L O RSF	132	110	AF9
NXC 0300 5 A 2 L O RSF	160	132	
NXC 0385 5 A 2 L O RSF	200	160	AF10
NXC 0460 5 A 2 L O RSF	250	200	
NXC 0520 5 A 2 L O RSF	250	250	AF12
NXC 0650 5 A 2 L O RSF	355	315	
NXC 0730 5 A 2 L O RSF	400	355	AF12
NXC 0820 5 A 2 L O RSF	450	400	
NXC 0920 5 A 2 L O RSF	500	450	AF12
NXC 1030 5 A 2 L O RSF	560	500	
NXC 1150 5 A 2 L O RSF	630	560	AF13
NXC 1300 5 A 2 L O RSF	710	630	
NXC 1450 5 A 2 L O RSF	800	710	AF13
NXC 1770 5 A 2 L O RSF	1000	900	
NXC 2150 5 A 2 L O RSF	1200	1100	AF14
NXC 2700 5 A 2 L O RSF	1500	1200	
Mains voltage 525-690 V, 50/60 Hz			
NXC 0125 6 A 2 L O RSF	110	90	AF9
NXC 0144 6 A 2 L O RSF	132	110	
NXC 0170 6 A 2 L O RSF	160	132	AF10
NXC 0208 6 A 2 L O RSF*	200	160	
NXC 0261 6 A 2 L O RSF	250	200	AF10
NXC 0325 6 A 2 L O RSF	315	250	
NXC 0385 6 A 2 L O RSF	355	315	AF12
NXC 0416 6 A 2 L O RSF*	400	315	
NXC 0460 6 A 2 L O RSF	450	355	AF12
NXC 0502 6 A 2 L O RSF	500	450	
NXC 0590 6 A 2 L O RSF	560	500	AF12
NXC 0650 6 A 2 L O RSF	630	560	
NXC 0750 6 A 2 L O RSF	710	630	AF12
NXC 0820 6 A 2 L O RSF*	750	650	
NXC 0920 6 A 2 L O RSF	900	800	AF13
NXC 1030 6 A 2 L O RSF	1000	900	
NXC 1180 6 A 2 L O RSF*	1150	1000	AF13
NXC 1500 6 A 2 L O RSF	1500	1300	
NXC 1900 6 A 2 L O RSF	1800	1500	AF14
NXC 2250 6 A 2 L O RSF*	2000	1800	

* Max. ambient temperature of +35°C

Dimensions VACON® NXC Low Harmonic

Enclosure size	Height	Width	Depth	Weight
	mm	mm	mm	kg
AF9	2275	1006	605	680
	2275	1006	605	680
AF10	2275	1006	605	700
	2275	1006	605	700
AF12	2275	2006	605	1400
	2275	2006	605	1400
	2275	2006	605	1400
	2275	2006	605	1400
	2275	2206	605	1950
	2275	2206	605	1950
AF13	2275	2206	605	1950
	2275	2206	605	1950
AF14	2275	4406	605	3900
	2275	4406	605	3900

VACON® NXP Liquid Cooled Active front-end (AFE)

AC drive type	DC power				Enclosure size
	400 VAC mains I _{th} [kW]	500 VAC mains I _{th} [kW]	400 VAC mains I _L [kW]	500 VAC mains I _L [kW]	
DC bus voltage 465-800 VDC					
NXA01685A0T02WS	113	142	103	129	CH5
NXA02055A0T02WS	138	173	125	157	
NXA02615A0T02WS	176	220	160	200	CH61
NXA03005A0T02WF	202	253	184	230	
NXA03855A0T02WF	259	324	236	295	CH62
NXA04605A0T02WF	310	388	282	352	
NXA05205A0T02WF	350	438	319	398	CH62
NXA05905A0T02WF	398	497	361	452	
NXA06505A0T02WF	438	548	398	498	CH63
NXA07305A0T02WF	492	615	448	559	
NXA08205A0T02WF	553	691	502	628	CH63
NXA09205A0T02WF	620	775	563	704	
NXA10305A0T02WF	694	868	631	789	CH64
NXA11505A0T02WF	775	969	704	880	
NXA13705A0T02WF	923	1154	839	1049	CH64
NXA16405A0T02WF	1105	1382	1005	1256	
NXA20605A0T02WF	1388	1736	1262	1578	CH64
NXA23005A0T02WF	1550	1938	1409	1762	

AC drive type	DC power				Enclosure size
	525 VAC mains I _{th} [kW]	690 VAC mains I _{th} [kW]	525 VAC mains I _L [kW]	690 VAC mains I _L [kW]	
DC bus voltage 640-1100 VDC¹⁾					
NXA01706A0T02WF	150	198	137	180	CH61
NXA02086A0T02WF	184	242	167	220	
NXA02616A0T02WF	231	303	210	276	CH62
NXA03256A0T02WF	287	378	261	343	
NXA03856A0T02WF	341	448	310	407	CH62
NXA04166A0T02WF	368	484	334	439	
NXA04606A0T02WF	407	535	370	486	CH63
NXA05026A0T02WF	444	584	403	530	
NXA05906A0T02WF	522	686	474	623	CH63
NXA06506A0T02WF	575	756	523	687	
NXA07506A0T02WF	663	872	603	793	CH64
NXA08206A0T02WF	725	953	659	866	
NXA09206A0T02WF	814	1070	740	972	CH64
NXA10306A0T02WF	911	1197	828	1088	
NXA11806A0T02WF	1044	1372	949	1247	CH64
NXA13006A0T02WF	1150	1511	1046	1374	
NXA15006A0T02WF	1327	1744	1207	1586	CH64
NXA17006A0T02WF	1504	1976	1367	1796	

¹⁾ DC bus voltage 640-1200 VDC for wide range voltage version (NX_8)

VACON® NXP Liquid Cooled Non-regenerative front-end (NFE)

AC drive type	DC power				Enclosure size
	400 VAC mains I _{th} [kW]	500 VAC mains I _{th} [kW]	400 VAC mains I _L [kW]	500 VAC mains I _L [kW]	
DC bus voltage 465-800 V DC, 6/12-pulse					
NXN20006A0T0	1282	1605	1165	1458	CH60

AC drive type	DC power				Enclosure size
	525 VAC mains I _{th} [kW]	690 VAC mains I _{th} [kW]	525 VAC mains I _L [kW]	690 VAC mains I _L [kW]	
DC bus voltage 640-1100 V DC, 6/12-pulse					
NXN20006A0T0	1685	2336	1531	2014	CH60

See the dimensions (mm) on page 35.



AC drives for marine applications

VACON® NXP Liquid Cooled

This dedicated liquid-cooled drive is well-suited to applications where air quality is critical, space is limited, and efficient heat transfer is required.

Compact

No need for air ducts or large fans, combined with a more compact

enclosure, mean you achieve a high power density in your installation – and virtually silent operation.

Achieve cost savings

Save on both investment and operating costs, since there is no need for large air-conditioning systems to remove heat. Achieve maximum uptime, because the drive operates reliably

even in demanding conditions. There is no need for air filtering in dusty conditions.

Highest control flexibility

The drive utilizes the full VACON® NXP family control functionality to achieve modularity and scalability in your application.

VACON® NXP Liquid Cooled AC drives, 6-pulse and 12-pulse, mains voltage 400-500 VAC

AC drive type 6-pulse	AC drive type 12-pulse	Motor shaft power		Enclosure size
		Optimum motor at I _{th} (400 V) [kW]	Optimum motor at I _{th} (500 V) [kW]	
NXP00165A0N1SWS		7.5	11	CH3
NXP00225A0N1SWS		11	15	
NXP00315A0N1SWS		15	18.5	
NXP00385A0N1SWS		18.5	22	
NXP00455A0N1SWS		22	30	
NXP00615A0N1SWS		30	37	CH4
NXP00725A0N0SWS		37	45	
NXP00875A0N0SWS		45	55	
NXP01055A0N0SWS		55	75	CH5
NXP01405A0N0SWS		75	90	
NXP01685A0N0SWS		90	110	
NXP02055A0N0SWS		110	132	CH61
NXP02615A0N0SWS		132	160	
NXP03005A0N0SWS		160	200	
NXP03855A0N0SWS		200	250	CH72
NXP04605A0N0SWS	NXP04605A0N0TWF	250	315	
NXP05205A0N0SWS	NXP05205A0N0TWF	250	355	
NXP05905A0N0SWS	NXP05905A0N0TWF	315	400	CH74
NXP06505A0N0SWS	NXP06505A0N0TWF	355	450	
NXP07305A0N0SWS	NXP07305A0N0TWF	400	500	
NXP08205A0N0SWS		450	560	CH63
NXP09205A0N0SWS		500	600	
NXP10305A0N0SWS		560	700	
NXP11505A0N0SWS		600	750	CH74
NXP13705A0N0SWS	NXP13705A0N0TWF	700	900	
NXP16405A0N0SWS	NXP16405A0N0TWF	900	1100	
NXP20605A0N0SWS	NXP20605A0N0TWF	1100	1400	2 x CH74
NXP23005A0N0SWS		1250	1500	
NXP24705A0N0SWS	NXP24705A0N0TWF	1300	1600	
NXP29505A0N0SWS	NXP29505A0N0TWF	1550	1950	4 x CH74
NXP37105A0N0SWS	NXP37105A0N0TWF	1950	2450	
NXP41405A0N0SWS	NXP41405A0N0TWF	2150	2700	
2 x NXP24705A0N0SWS	2 x NXP24705A0N0TWF	2450	3050	4 x CH74
2 x NXP29505A0N0SWS	2 x NXP29505A0N0TWF	2900	3600	
2 x NXP37105A0N0SWS	2 x NXP37105A0N0TWF	3600	4500	
2 x NXP41405A0N0SWS	2 x NXP41405A0N0TWF	4100	5150	

VACON® NXP Liquid Cooled AC drives, 6-pulse and 12-pulse, mains voltage 525-690 VAC

AC drive type 6-pulse	AC drive type 12-pulse	Motor shaft power		Enclosure size
		Optimum motor at I _{th} (525 V) [kW]	Optimum motor at I _{th} (690 V) [kW]	
NXP01706A0T0SWS		110	160	CH61
NXP02086A0T0SWS		132	200	
NXP02616A0T0SWS		160	250	
NXP03256A0T0SWS	NXP03256A0T0TWF	200	300	CH72
NXP03856A0T0SWS	NXP03856A0T0TWF	250	355	
NXP04166A0T0SWS	NXP04166A0T0TWF	250	355	
NXP04606A0T0SWS	NXP04606A0T0TWF	300	400	CH63
NXP05026A0T0SWS	NXP05026A0T0TWF	355	450	
NXP05906A0T0SWS		400	560	
NXP06506A0T0SWS		450	600	CH74
NXP07506A0T0SWS		500	700	
NXP08206A0T0SWS	NXP08206A0T0TWF	560	800	
NXP09206A0T0SWS	NXP09206A0T0TWF	650	850	2 x CH74
NXP10306A0T0SWS	NXP10306A0T0TWF	700	1000	
NXP11806A0T0SWS	NXP11806A0T0TWF	800	1100	
NXP13006A0T0SWS	NXP13006A0T0TWF	900	1200	4 x CH74
NXP15006A0T0SWS	NXP15006A0T0TWF	1050	1400	
NXP17006A0T0SWS	NXP17006A0T0TWF	1150	1550	
NXP18506A0T0SWS	NXP18506A0T0TWF	1250	1650	4 x CH74
NXP21206A0T0SWS	NXP21206A0T0TWF	1450	1900	
NXP23406A0T0SWS	NXP23406A0T0TWF	1600	2100	
NXP27006A0T0SWS	NXP27006A0T0TWF	1850	2450	4 x CH74
NXP31006A0T0SWS	NXP31006A0T0TWF	2150	2800	
2 x NXP18506A0T0SWS	2 x NXP18506A0T0TWF	2400	3150	
2 x NXP21206A0T0SWS	2 x NXP21206A0T0TWF	2750	3600	4 x CH74
2 x NXP23406A0T0SWS	2 x NXP23406A0T0TWF	3050	3950	
2 x NXP27006A0T0SWS	2 x NXP27006A0T0TWF	3500	4600	
2 x NXP31006A0T0SWS	2 x NXP31006A0T0TWF	4050	5300	



For more information please see: [VACON® NXP Liquid Cooled selection guide.](#)



VACON® NXP Liquid Cooled inverter units, DC bus voltage 465-800 VDC

AC drive type	Motor shaft power		Enclosure size
	Optimum motor at I _{th} (540 VDC) [kW]	Optimum motor at I _{th} (675 VDC) [kW]	
NXP00165A0T1IWS	7,5	11	CH3
NXP00225A0T1IWS	11	15	
NXP00315A0T1IWS	15	18,5	
NXP00385A0T1IWS	18,5	22	
NXP00455A0T1IWS	22	30	
NXP00615A0T1IWS	30	37	CH4
NXP00725A0T0IWS	37	45	
NXP00875A0T0IWS	45	55	
NXP01055A0T0IWS	55	75	
NXP01405A0T0IWS	75	90	
NXP01685A0T0IWS	90	110	CH5
NXP02055A0T0IWS	110	132	
NXP02615A0T0IWS	132	160	
NXP03005A0T0IWF	160	200	CH61
NXP03855A0T0IWF	200	250	
NXP04605A0T0IWF	250	315	CH62
NXP05205A0T0IWF	250	355	
NXP05905A0T0IWF	315	400	
NXP06505A0T0IWF	355	450	
NXP07305A0T0IWF	400	500	
NXP08205A0T0IWF	450	560	CH63
NXP09205A0T0IWF	500	600	
NXP10305A0T0IWF	560	700	
NXP11505A0T0IWF	600	750	
NXP13705A0T0IWF	700	900	
NXP16405A0T0IWF	900	1100	CH64
NXP20605A0T0IWF	1100	1400	
NXP23005A0T0IWF	1250	1500	
NXP24705A0T0IWF	1300	1600	
NXP29505A0T0IWF	1550	1950	
NXP37105A0T0IWF	1950	2450	2 x CH64
NXP41405A0T0IWF	2150	2700	
2 x NXP24705A0T0IWF	2450	3050	4 x CH64
2 x NXP29505A0T0IWF	2900	3600	
2 x NXP37105A0T0IWF	3600	4500	
2 x NXP41405A0T0IWF	4100	5150	

The voltage classes for the inverter units used in the tables above have been defined as follows:
 Input 540 VDC = Rectified 400 VAC supply
 Input 675 VDC = Rectified 500 VAC supply

VACON® NXP Liquid Cooled inverter units, DC bus voltage 640-1100 VDC

AC drive type	Motor shaft power		Enclosure size
	Optimum motor at I _{th} (710 VDC) [kW]	Optimum motor at I _{th} (930 VDC) [kW]	
NXP01706A0T0IWF	110	160	CH61
NXP02086A0T0IWF	132	200	
NXP02616A0T0IWF	160	250	
NXP03256A0T0IWF	200	300	CH62
NXP03856A0T0IWF	250	355	
NXP04166A0T0IWF	250	355	
NXP04606A0T0IWF	300	400	
NXP05026A0T0IWF	355	450	
NXP05906A0T0IWF	400	560	CH63
NXP06506A0T0IWF	450	600	
NXP07506A0T0IWF	500	700	
NXP08206A0T0IWF	560	800	CH64
NXP09206A0T0IWF	650	850	
NXP10306A0T0IWF	700	1000	
NXP11806A0T0IWF	800	1100	
NXP13006A0T0IWF	900	1200	
NXP15006A0T0IWF	1050	1400	
NXP17006A0T0IWF	1150	1550	
NXP18506A0T0IWF	1250	1650	
NXP21206A0T0IWF	1450	1900	
NXP23406A0T0IWF	1600	2100	
NXP27006A0T0IWF	1850	2450	2 x CH64
NXP31006A0T0IWF	2150	2800	
2 x NXP18506A0T0IWF	2400	3150	4 x CH64
2 x NXP21206A0T0IWF	2750	3600	
2 x NXP23406A0T0IWF	3050	3950	
2 x NXP27006A0T0IWF	3500	4600	
2 x NXP31006A0T0IWF	4050	5300	



VACON® NXP Liquid Cooled enclosed drive

AC drive type	Electrical output power		Enclosure size
	Motor at I _{th} (525 VAC) [kW]	Motor at I _{th} (690 VAC) [kW]	
0820_6	560	800	CH64
0920_6	650	850	
1030_6	700	1000	
1180_6	800	1100	
1300_6	900	1200	
1500_6	1000	1400	
1700_6	1150	1550	

VACON® options for Liquid Cooled NXP Heat exchangers

Product code	Description
HXM-M-120-N-S	Heat exchanger unit stand; up to 120 kW, 360 l/min; Stainless steel piping, 2-pump
HXM-M-300-N-S	Heat exchanger unit stand; up to 300 kW, 900 l/min; Stainless steel piping, 2-pump
HXM-R-120-N-S	Heat exchanger unit installed into Rittal TS8 cabinet; up to 120 kW, 360 l/min; Stainless steel piping, 2-pump
HXM-R-300-N-S	Heat exchanger unit installed into Rittal TS8 cabinet; up to 300 kW, 900 l/min; Stainless steel piping, 2-pump
HXM-V-120-N-S	Heat exchanger unit installed into VEDA cabinet; up to 120 kW, 360 l/min; Stainless steel piping, 2-pump

See the dimensions (mm) on page 35.

 **For more information please see:**
[VACON® NXP Liquid Cooled selection guide.](#)

AC drives for marine applications

VACON® NXP System Drive

The VACON® NXP System Drive provides a strong package, comprising the complete offering for enclosed common DC systems, supplied consistently and quickly.

Simplicity in your project

Using pre-designed sections enables a short engineering lead time. The systems are fully documented, and adaptable to the specifics of your project for easy implementation.

Reliability is key

You can rest assured that performance is absolutely reliable, with verified and tested solutions that combine VACON® AC drives, DC bus components and options.

Easy serviceability

Enjoy easy access with design for fast service. Safety is a priority with internal touch protection and high power busbar sections in separate compartments. Any problem which arises is contained, and does not cause widespread failure.

VACON® NXP Grid Converter

This range of air- and liquid-cooled drives is specifically designed for energy storage and marine energy management applications.

Reliable grid

By creating and maintaining a stable electrical power grid, a reliable grid is assured in all applications.

The VACON® NXP Grid Converter provides a reliable shore supply for ships in harbor, meaning no need to run on-board generators.

Save on fuel and emissions

Fuel savings and reduced emissions are the immediate benefits achieved by eliminating generators.

VACON® NXP DC/DC Converter

Utilizing any of the air- or liquid-cooled NXP inverter modules, the DC to DC converter includes a specific licensed firmware to provide DC power conversion.

Connect to other DC sources

The DC to DC converter allows common DC bus systems or individual drives to connect their DC bus to alternate DC sources such as batteries or super capacitors to create hybrid systems.



For more information please see:

[VACON® NXP System Drive](#) and [VACON® NXP Grid Converter](#) selection guides.



VACON® NXP Grid Converter 465-800 VDC, type open, liquid-cooled, EMC Class T

Product code	DC power				Enclosure size
	400 VAC mains	500 VAC mains	400 VAC mains	500 VAC mains	
	I_{TH} [kW]	I_{TH} [kW]	I_L [kW]	I_L [kW]	
NXA02615A0T02WVA1A2000000+MASG	176	220	160	200	CH5
NXA03855A0T02WGA1A2000000+MASG	259	324	236	295	CH61
NXA05205A0T02WGA1A2000000+MASG	350	438	319	398	CH62
NXA07305A0T02WGA1A2000000+MASG	492	615	448	559	CH63
NXA09205A0T02WGA1A2000000+MASG	620	775	563	704	CH63
NXA11505A0T02WGA1A2000000+MASG	775	969	704	880	CH63
NXA16405A0T02WGA1A2000000+MASG	1105	1382	1005	1256	CH64
NXA23005A0T02WGA1A2000000+MASG	1550	1938	1409	1762	CH64

VACON® NXP Grid Converter 640-(1200)* IP00, liquid-cooled, EMC Class T

Product code	DC power				Enclosure size
	525 VAC mains	690 VAC mains	525 VAC mains	690 VAC mains	
	I_{TH} [kW]	I_{TH} [kW]	I_L [kW]	I_L [kW]	
NXA02616A0T02WGA1A2000000+MASG	231	303	210	276	CH61
NXA03856A0T02WGA1A2000000+MASG	341	448	310	407	CH62
NXA05026A0T02WGA1A2000000+MASG	444	584	403	530	CH62
NXA07506A0T02WGA1A2000000+MASG	663	872	603	793	CH63
NXA11806A0T02WGA1A2000000+MASG	1044	1372	949	1247	CH64
NXA15006A0T02WGA1A2000000+MASG	1327	1744	1207	1586	CH64
NXA17006A0T02WGA1A2000000+MASG	1504	1976	1367	1796	CH64

* With voltage class 8

VACON® NXP Grid Converter 380-500 V, IP00 air-cooled, EMC Class T

Product code	Low overload 110% / 40°C		High overload 150% / 40°C		DC power		Enclosure size
	I_{L-cont} [A]	$I_{1 min}$ [A]	I_{H-cont} [A]	$I_{1 min}$ [A]	400 VAC mains P_{L-cont} [kW]	500 VAC mains P_{L-cont} [kW]	
	NXA02615A0T02SGA1A2000000+MASG	261	287	205	308	176	
NXA04605A0T02SGA1A2000000+MASG	460	506	385	578	310	388	F110
NXA13005A0T02SGA1A2000000+MASG	1300	1430	1150	1725	876	1092	F113

VACON® NXP Grid Converter 525-690 V, IP00, air-cooled, EMC Class T

Product code	Low overload 110% / 40°C		High overload 150% / 40°C		DC power		Enclosure size
	I_{L-cont} [A]	$I_{1 min}$ [A]	I_{H-cont} [A]	$I_{1 min}$ [A]	600 VAC mains P_{L-cont} [kW]		
	NXA01706A0T02SGA1A2000000+MASG	170	187	144	216	198	
NXA03256A0T02SGA1A2000000+MASG	325	358	261	392	378		F110
NXA10306A0T02SGA1A2000000+MASG	1030	1133	920	1380	1195		F113

VACON® NXP Liquid Cooled dimensions: drives consisting of one module

Enclosure size	IP00
	W x H x D [mm]
CH3	160 x 431 x 246
CH4	193 x 493 x 257
CH5	246 x 553 x 264
CH60	246 x 673 x 374
CH61/62	246 x 658 x 372
CH63	505 x 923 x 375
CH64	746 x 923 x 375
CH72	246 x 1076 x 372
CH74	746 x 1175 x 385

VACON® NXP Air Cooled dimensions: drives consisting of one module

Enclosure size	IP00
	W x H x D [mm]
F19	239 x 1030 x 372
F110	239 x 1032 x 552
F113	708 x 1032 x 553



For more information please see:

VACON® NXP System Drive and VACON® NXP Grid Converter selection guides.



Certified solutions to control harmonics

- Advanced active filters
- Advanced harmonic filters
- Low harmonic drives
- 12-pulse drives
- Active front end drives

Adverse effects of harmonics

- Limitations on supply and network utilization
- Increased transformer, motor and cable heating
- Reduced equipment lifetime
- Costly equipment downtime
- Control system malfunctions
- Pulsating and reduced motor torque
- Audible noise

Harmonics mitigation

While AC drives increase precision, save energy and extend application lifetime, they also introduce harmonic currents to the on-board grid. If not kept under control, this can affect the performance and reliability of generators and other equipment and, ultimately, compromise safety.

Danfoss offers harmonic mitigation solutions to comply with the regulations imposed by marine certification bodies, which state that harmonics must be kept to 5 or 8% total harmonic voltage distortion (THDv) on the main busbar.

Danfoss has developed a wide range of mitigation solutions which can help restore weak networks, increase network capacity, and meet compact retrofit demands – or secure sensitive environments.

Low harmonic drives

The VLT® and VACON® low harmonic drives continuously regulate the network and load conditions without affecting the connected motor. The drives combine the well-known performance and reliability of standard VLT® and VACON® drives with an Advanced Active Filter. The result is a powerful, motor-friendly solution that provides the highest possible harmonic mitigation with total harmonic current distortion (THDi) of maximum 5%.

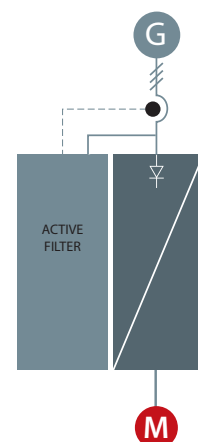

Advanced active filters

Advanced active filters identify harmonic distortion from non-linear loads and inject counter-phase harmonic and reactive currents into the AC line to cancel out the distortion. The result is distortion levels of no more than 5% THDi. The optimal sinusoidal waveform of the AC power is restored and the power factor of the system is re-established at 1.

Advanced active filters follow the same design principles as all our other drives. The modular platform provides high energy efficiency, user-friendly operation, efficient cooling and high enclosure ratings.

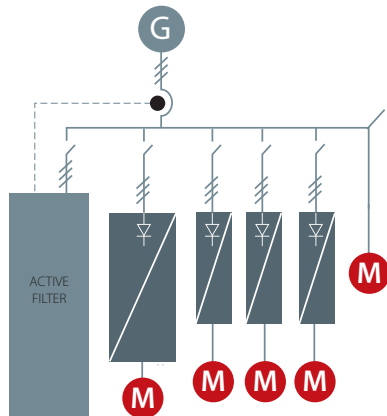

12-pulse drives

A robust and cost-effective harmonic solution for the higher power range, the Danfoss 12-pulse drive variants offer reduced harmonics for demanding industry applications above 250 kW.

VLT® and VACON® 12-pulse drives are high efficiency AC drives which are built with the same modular design as the popular 6-pulse drives. The 12-pulse variant is available with similar drive options and accessories and can be configured according to your specific needs.

The VLT® and VACON® 12-pulse drives provide harmonic reduction without adding capacitive or inductive components which often require network analysis to avoid potential system resonance problems.

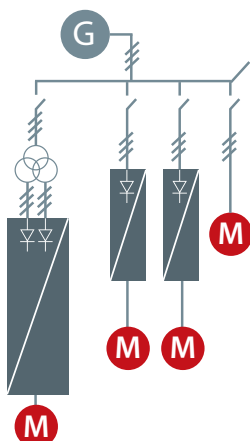

Advanced harmonic filters

The Danfoss harmonic filters are specially designed to be connected in front of a VLT® or VACON® drive, and ensure that the harmonic current distortion generated back to the mains is reduced to a minimum. Easy commissioning saves installation costs, and due to the maintenance-free design, running expenses for the units are eliminated.

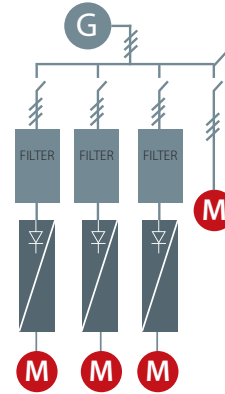

Active front-end drives

The clear advantage of active front-end (AFE) drives is that any back power generated can be used by other equipment on the vessel. This adds to the overall fuel saving and reduces costs in running equipment.

An AFE system is a regenerative power converter located at the front end of a common DC bus drive line-up, and is suitable in applications where:

- Low harmonics are required
- The frequency inverter load is up to 100% of the total generator capacity

The AFE system comprises two identical inverters with a common DC bus. There is one motor inverter and one supply inverter. The supply inverter works together with a tuned sinus filter, and the current distortion (THDi) at the supply is about 3-4%.

When an AFE system is installed, then the motor voltage can be increased above that of the network, because adjustment of the DC link voltage is enabled. Any excessive energy can be returned to the network as clean (active) power, rather than reactive power, which only produces heat.



We know Marine and Offshore

Working in the challenging world of the maritime and offshore industries, you demand a supplier who contributes to improving efficiency, safety and reliability while reducing total cost of ownership. Danfoss is a single supplier who delivers on all these criteria – and more.

For over 40 years, we have worked to make the marine industry safer and more efficient, by building and consolidating successful relationships with:

- Ship owner-operators
- Shipyards
- System integrators
- OEMs
- Naval design engineers
- Naval architects

Represented in all major marine hubs with full marine certification and global service, Danfoss is committed to creating a sustainable, competitive future for the marine industry.



VLT® and VACON® drives Maximum uptime and efficiency

VLT® and VACON® drives are designed and built for maximum uptime and robust performance, which is critical in the marine business, where repair and maintenance must be kept to a minimum. Our drives have the highest number of class type approvals – from nine authorities. This gives you the best possible choice when selecting drives for your marine application.



High Pressure Pumps Ultra-low energy consumption Rugged construction

Danfoss' dedicated high-pressure pumps are built on decades of development experience to provide exceptional efficiency and reliability in seawater reverse osmosis applications. Small in size and unsurpassed in engineering quality, the Danfoss range of APP pumps is at the heart of more than 15,000 seawater reverse osmosis systems throughout the world.



Visit:
[Danfoss High Pressure Pumps](#)



Industrial Refrigeration Precise temperature control and zero corrosion

The fishery industry requires fast, efficient and durable refrigeration solutions, both when at sea and during on-shore processing. Danfoss offers a wide range of stainless steel components for the fishery industry. These components make design easy, reduce maintenance, and lower operating costs, even at high pressure and in demanding marine conditions.



Visit:
[Danfoss Industrial Refrigeration](#)



Industrial Automation Increased efficiency throughout the entire ship

With a solid 40 years' marine expertise in control and monitoring solutions, Danfoss Industrial Automation offers the widest product portfolio in the market. Danfoss sensors, switches and fluid controls empower operators to sail smarter, faster and more efficiently. Our product portfolio put you in control of the processes that let you fine-tune performance. Controls for marine applications must be as dependable as they are safe. That's why the Danfoss range of controls have all achieved independent type approval and certification.

 **Visit:**
[Danfoss Industrial Automation](#)



Danfoss IXA Emission gas measurement

Danfoss IXA's marine emission sensor provides the marine industry with a solution that meets the constantly increasing focus on the environment, and regulations regarding emissions control that have followed from this. Built extremely robust and with cutting edge technology, the sensor enables ships to precisely- and continuously measure the environmentally harmful gases NO_x, SO₂ and NH₃. These data provide valuable input for documentation and performance optimization.

 **Visit:**
[Danfoss IXA](#)



Danfoss Semco Leaders in marine firefighting

At sea, safety is paramount. With over 50 years of experience in designing and installing water mist, CO₂ and foam systems, Danfoss Semco is a global leader in delivering total solutions for certified fixed firefighting systems.

 **Visit:**
[Danfoss Semco](#)

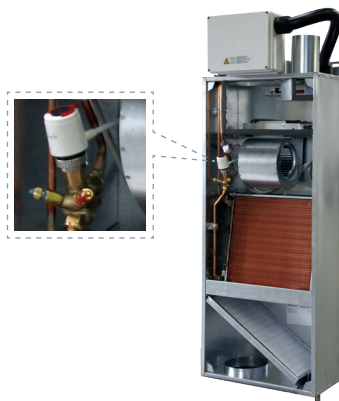

Hydronic Balancing and Control

Save fuel and installation costs and increase passenger comfort

Pressure-independent balancing and control valves ensure that the precise amount of cooling reaches passenger cabin fan coils and air handling units. Their linear control characteristic enables stable flow modulation to match demand, radically reducing energy used by chillers and pumps while providing higher comfort for passengers. No other HVAC solution is as efficient.

 **Visit:**
[Danfoss Hydronic Balancing
and Control](#)



Sondex® Heat Exchangers Highly efficient and service friendly heat exchangers

Our heat exchangers are designed for best possible thermal performance. On top of this, features developed over time ensure that our heat exchangers are easy to install and service. For example, we use the clever carrying- and guide bar, that ensures perfect alignment of the individual plates, while allowing good access during servicing. Our wide range of plate types are available in materials suitable for marine applications, with connections ranging from DN 25 up DN 650.

 **Visit:**
[Danfoss Sondex Heat Exchangers](#)



Power Solutions

Powerful hydraulics for highest efficiency and minimum downtime

When hydraulics and electronic controls are preferred, Danfoss Power Solutions offers the highest quality products and systems expertise to match your customers' demands. The broad portfolio includes rugged PVG load-sensing proportional valves for enhanced design flexibility and safety, powerful H1 axial piston pumps and bent axis motors for improved reliability and efficiency, and easy system integration and control with PLUS+1° microcontrollers and software. With Danfoss hydraulic marine solutions, you get the best of quality and a minimum of downtime.

 **Visit:**
[Danfoss Power Solutions](#)

Danfoss products are **everywhere on the ship** – improving **efficiency, safety** and **reliability**

Cargo deck

- Firefighting systems
- VLT® and VACON® drives
- Pressure and temperature sensors and controls
- Hydraulic valves and motors

Accommodation

- Control valves for air-conditioning
- Firefighting systems
- VLT® and VACON® drives
- Floor-heating systems

Winches

- VLT® and VACON® drives
- Hydraulic valves, motors and control systems



Engine room

- VLT® and VACON® drives
- Pressure and temperature sensors and controls
- IXA emission sensors
- Fluid controls
- Firefighting systems
- Hydraulic pumps, valves and motors
- Heat exchangers

Utilities

- High-pressure pumps
- VLT® and VACON® drives
- Pressure and temperature sensors and controls
- Fluid controls
- Refrigeration controls
- Firefighting systems
- Heat exchangers

Thrusters

- VLT® and VACON® drives
- Pressure and temperature sensors and controls
- Firefighting systems
- Hydraulic valves and motors



For further information please visit www.marine.danfoss.com