

Data Sheet

Danfoss Regus® thermostatic sensors series

Application



The Danfoss Regus® series is a comprehensive portfolio of high quality thermostatic sensors, produced in Denmark.

The Danfoss Regus® thermostat uses liquid-filled technology, that gives optimum reaction time and compact sensor size to fit most applications.

The Danfoss Regus® thermostat is installed onto a radiator valve. The combination of the thermostat and radiator valve, controls the individual room temperature at a given setpoint by adjusting the flow of hot water through the radiator.

The Danfoss Regus® thermostat is applicable to all types of heating applications, including applications with small calculated P-band.

Danfoss Regus® series includes:

- Standard thermostats with built-in sensor
- Variants with connection for radiator valves and radiators with integrated valves, type Danfoss RA
- Variants with M30x1.5 connection for radiator valves and radiators with integrated valves
- Variants with max or min limited temperature setting range

Features:

- Liquid-filled thermostat with precise temperature control
- Optimum reaction time in thermostatic sensor category
- Highest-class Control Accuracy (CA 0.2 K) per amended EN215
- Easy to operate, easy to clean
- Easy to set with ergonomic torque to turn the head to desired setting
- Facilities designed for the visually impaired
- Facilities for limiting and locking temperature set-point
- Frost protection setting
- A theft protection, from factory or available as accessory

Quality



Danfoss Regus® thermostatic sensors are certified according to the European standard EN 215.

All Danfoss radiator thermostats are manufactured in factories, assessed and certified by by BVC (Bureau Veritas Certification) against ISO 9001 and ISO 14001.

Datasheet

Danfoss Regus® Thermostatic sensors series







Technical data

Type	Sensor	Response time	Differential pressure influence (D)	Hysteresis (C)	Water temperature influence (W)	Control Accuracy (CA)
Regus RA	Built-in	22 mins	0.10 K	0.20 K	0.68 K	0.2 K
Regus M30	Built-in	22 mins	0.10 K	0.40 K	0.48 K	0.2 K

Ordering and Specification

Type	Model	Sensor	Set point range	Connection	Zero blocking	Limiter pins	EN215 Certified	Code no.
Regus RA	Standard	Built-in	8-28°C	RA		✓	✓	015G3690
Regus RA	Standard	Built-in	8-28°C	RA	✓	✓	✓	015G3818
Regus RA	Standard	Built-in	8-28°C	RA	✓	✓	✓	015G3698
Regus RA	Limited	Built-in	15-28°C	RA		✓		015G3695
Regus RA	Limited	Built-in	16-28°C	RA		✓	✓	015G3696
Regus M30	Standard	Built-in	8-28°C	M30x1.5		✓		015G3630
Regus M30	Standard	Built-in	8-28°C	M30x1.5	✓	✓		015G3839
Regus M30	Standard	Built-in	8-28°C	M30x1.5	✓	✓	✓	015G5312
Regus M30	Limited	Built-in	16-28°C	M30x1.5		✓		015G3636

Accessories

Accessories	Code no.
 Theft protection for RA sensors	015G3910
 Theft protection for M30 sensors (10 pcs.)	013G5287
 Blocking pin (130 pcs.)	013G5199
 Partner clip	015G3900
 Angle adapter for Danfoss RA sensors	013G1350
 Angle adapter for M30 x 1.5 connection	013G1360

Datasheet

Danfoss Regus® Thermostatic sensors series

Construction

Danfoss Regus® RA

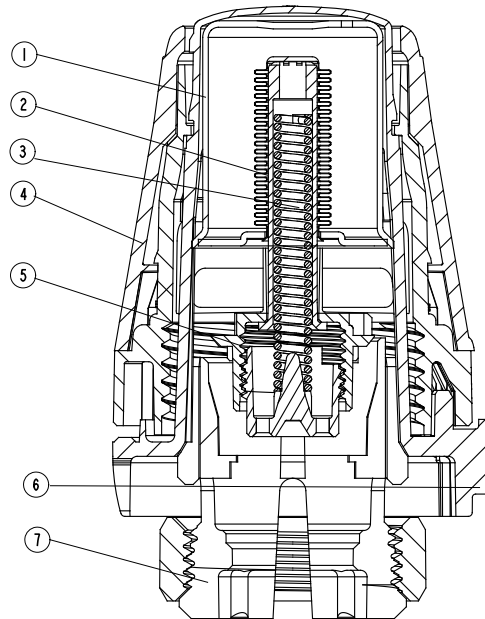

Danfoss Regus® M30

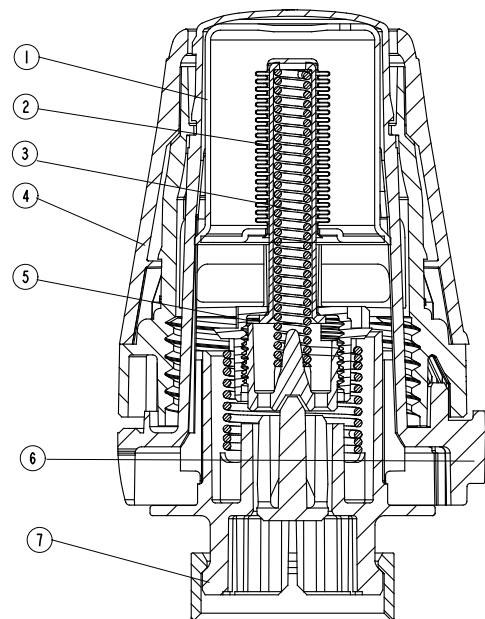

- 1 Actuator
- 2 Liquid filled bellow
- 3 Spring
- 4 Setting handle
- 5 Spindle
- 6 Setting mark
- 7 Socket

Operating Principle

Thermostatic sensors are proportional controls, regulating the heat supply in relation to the difference between the temperature set on the sensor and the temperature of ambient air, detected by the thermostat.

The thermal expansion element (bellow) responds to room temperature by expanding or contracting proportionally. The movement is transmitted onto the control element of the thermostatic valve.

The thermostatic sensor controls the amount of water which flows into radiator to the suitable flow level that is required to maintain the room temperature on the set level.

Danfoss Regus® series of thermostatic sensors are fitted with liquid-filled bellows, ensuring fast response time to changing ambient temperature.

Datasheet

Danfoss Regus® Thermostatic sensors series

Setting the temperature

The required room temperature is set by turning the setting dial. The temperature scales below shows the correlation between scale values and the room temperature. The temperature values stated are for guidance only as the obtained room temperature will often be influenced by installation conditions.

Locking and limitation of the temperature set-point of the Danfoss Regus® thermostats are carried out using the invisible limiters placed at the side of the sensor.

The procedure is described in the instruction.

Danfoss Regus®



Setting position

❄	1	2	3	4	5
8	12	16	20	24	28 °C

Room temperature

❄ = Frost protection setting

Danfoss Regus® 015G6396



Setting position

	2	3	4	5
	16	20	24	28 °C

Room temperature

Choose the right sensor

The thermostatic sensor should be selected on the basis of the following criteria:

The thermostat must always be able to register the temperature of the ambient air.

Radiator thermostats with built-in sensors

These should always be fitted horizontally so that the ambient air can pass freely over the sensor. Danfoss does not recommend the fitting of a built-in sensor in vertical position because heat effect from the valve body and possibly surface pipes will cause incorrect operation of the thermostat.

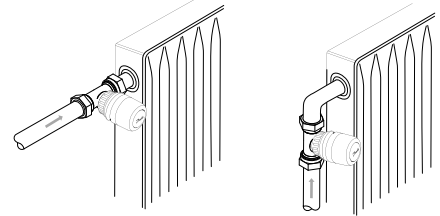

Radiator thermostats with remote sensor

These should be used when:

- Curtains cover the thermostat
- Thermostat is affected by surface pipes
- Thermostat is affected by draught
- It is necessary to mount the thermostat in vertical position if there are adjacent obstructions.

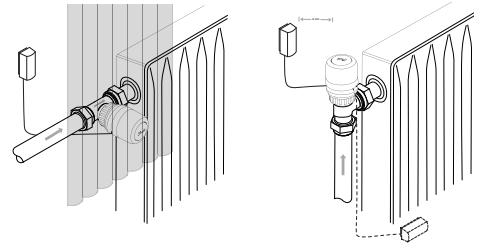

The remote sensor must be mounted on the wall, away from curtains, or on the skirting board beneath the radiator if free of surface pipes.

All remote sensors are now supplied with ultra-thin capillary tube. Simply pull out the length required (2 m maximum) and fix using clips provided or a special tacker gun.

Dimensions

Danfoss Regus® RA

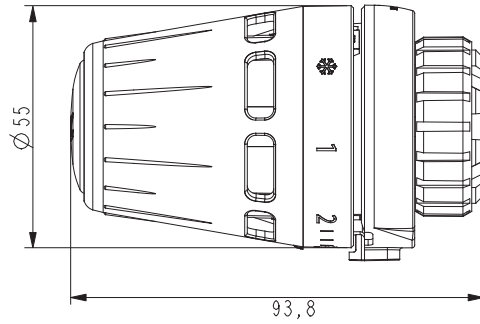

Danfoss Regus® M30

