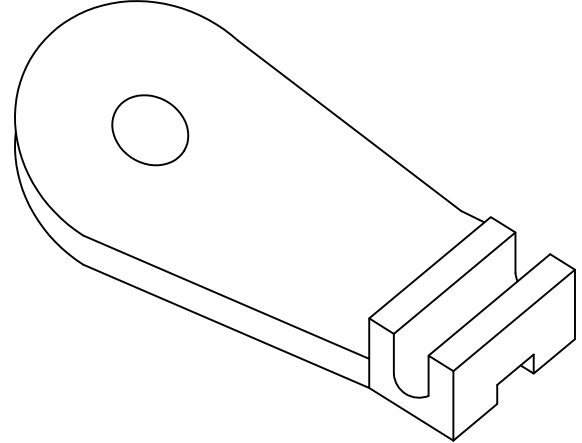
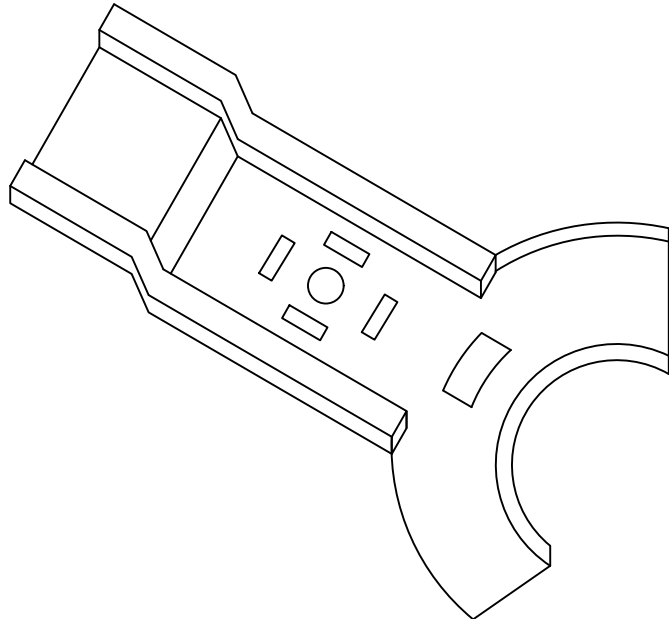
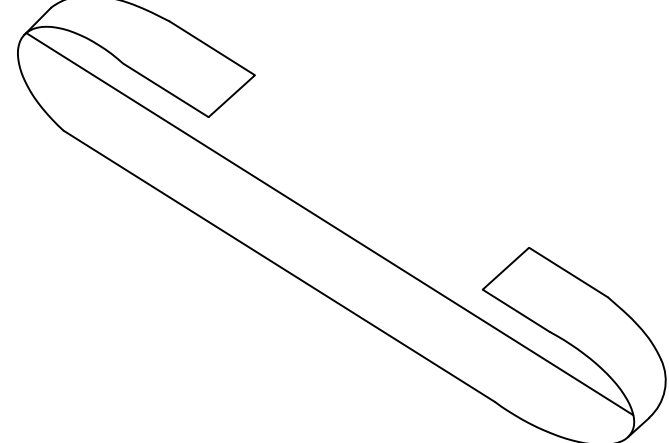
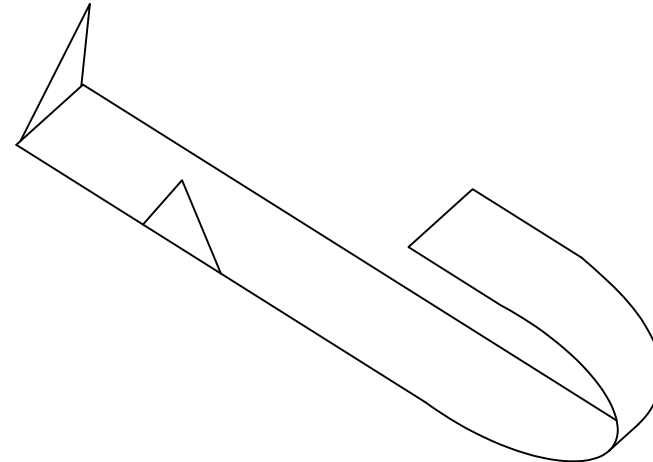
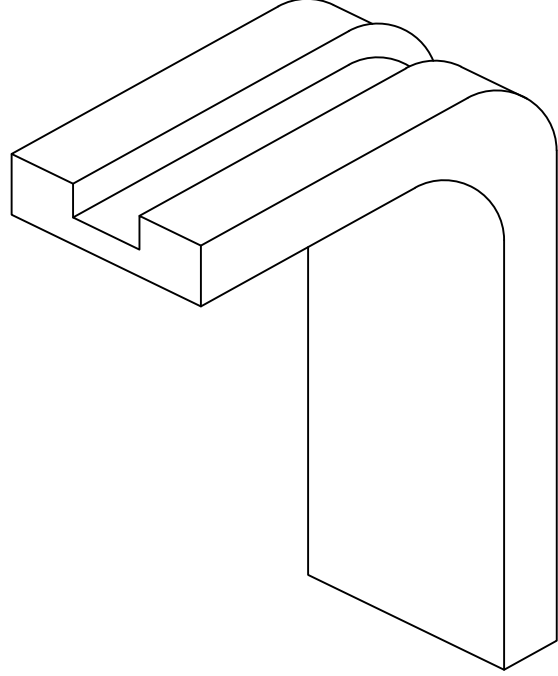
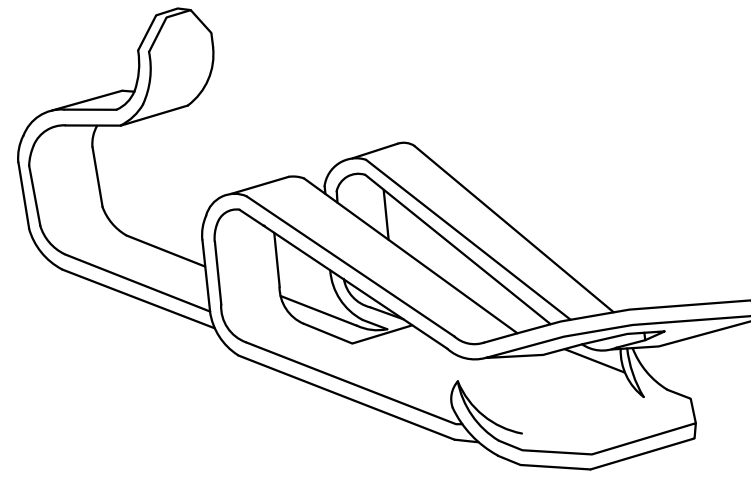
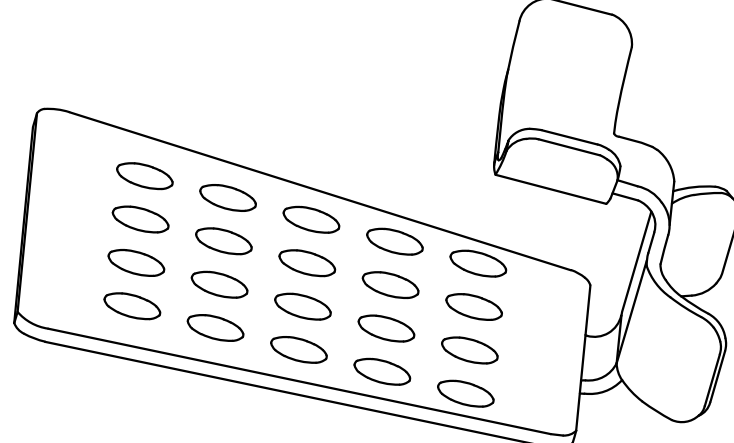

LEGEND

DRAWING LIST

	RX-C Roof Clips Type A 088L3024
	RX-C Roof Clips Type B 088L3003
	Spacer Clips 088L3004
	Shingle Clips 088L3005
	RX Downspout Edge Protection Plate 088L3002
	Shingle Clips 088L3012
	RX Roof Clips 088L3001

RX-1	Legend/Drawing List
RX-2	RX Constant Watt Cable Specification
RX-3	RX Self-Regulating Cable Specification
RX-4	RX Typical Roof Install
RX-5	RX Typical Dorm, Valley & Downspout Install
RX-6	DS-8C Application
RX-7	GX-850M Application
RX-8	RX-1200 Application

1.	Date	Desc.
----	------	-------

No: Date: Description:

Rep:

Project:

RX General Submittal

Drawing Title:

Legend/Drawing List



11655 Crossroads Circle
Baltimore, Maryland 21220
Tel: 1-888-326-3677 Option: 3 Fax : 1 410-931-8256
www.Heating.Danfoss.us

The Contractor shall verify all job site dimensions all drawing, details & specifications.

The Contractor shall report any discrepancies, in writing to Danfoss prior to commencing with any work.

Date:	Quote No:
-------	-----------

March 2018	
------------	--

Drawn By:	Scale:
-----------	--------

Drawing No:

RX-1

RX Constant Watt Cable Specification

1. General

Supply and install a complete system comprised of heating cables, accessories and controls for keeping roof eaves, gutters and downspouts from being clogged by ice and snow.

2. Material

- 2.1. Shall be Danfoss RX kits dual conductor heating cable.
- 2.2. Conductor: Copper or copper alloy with nickel coating.
- 2.3. Insulation: FEP DuPont with an average thickness not less than 0.25 mm and than layer of XLPE.
- 2.4. Shield: Tin coated drain wire combined with 0.050 mm aluminium foil coated with 0.012 mm PBT, 100% coverage.
- 2.5. Jacket: PVC with an average thickness not less than 0.75 mm.
- 2.6. Lead free 1/4" round heating cable that is both flexible and UV protected.
- 2.7. Rated temperature: 220 °F (105 °C), maximum voltage 277 V.
- 2.8. Shall include 6' cold lead with heavy duty grounded plug.
- 2.9. Heating cable circuit shall be protected by a ground fault device in accordance with section 426 of the NEC.
- 2.10. Shall be approved to applicable UL and CSA standards.

3. System Controls

Option 1: Automatic Snow Controller
The system shall be controlled by Danfoss GX 850 control panel with external digital temperature and moisture sensors either directly or through an appropriate contactor.

- 1.1. Automatic Snow Controller shall be microprocessor based to provide effective, economical, automatic control.
- 1.2. Automatic Snow Controller shall have dual zone capability.

- 1.3. Automatic Snow Controller shall have an adjustable timer providing up to ninety minutes of system operation after snowfall ceases for complete melting.
- 1.4. Automatic Snow Controller shall have the following modes.
 - a. Automatic
 - b. Constant OFF
 - c. Constant ON (manual timer)
- 1.5. Automatic Snow Controller shall have adjustable parameters
 - a. Melting Temperature (32°F to 49°F)
 - b. Timer (5 to 95 minutes)
- 1.6. Automatic Snow Controller shall be able to indicate the actual temperature and moisture levels for sensors.
- 1.7. Automatic Snow Controller shall have info-button for help/information.
- 1.8. Automatic Snow Controller shall have self-diagnosis program, which will detect faults and give them an alarm.
- 1.9. Automatic Snow Controller shall have individual LEDs to provide indication of alarm and heater operation.
- 1.10. Automatic Snow Controller shall be capable of accepting four roof sensors.
- 1.11. Automatic Snow Controller shall have multi-language capabilities (English, Spanish, and French)
- 1.12. Sensors shall include 50' lead.

Option 2: Snow Switch Control
The system shall be controlled by Danfoss DS-8 temperature and moisture sensor either directly or through an appropriate contactor.

- 2.1. DS-8 shall be microprocessor-based to provide effective, economical, automatic control.
- 2.2. DS-8 shall have an adjustable timer providing up to ninety minutes of system operation after snowfall ceases for complete melting.

- 2.3. DS-8 Snow Controller shall have the following modes.
 - a. Manual ON
 - b. Automatic
 - c. Standby/Reset
- 2.4. DS-8 Snow Controller shall have adjustable parameters
 - a. Melting Temperature (34°F to 44°F)
 - b. Timer (30 to 90 minutes)
- 2.5. DS-8 Snow Controller shall have two sensors: Moisture and Temperature.

Option 3: Thermostat
The system shall be controlled by an ambient sensing thermostat Danfoss 088L3422 either directly or through an appropriate contactor.

Option 4: Manual Switch
The system shall be controlled by a manual switch either directly or through an appropriate contactor.

4. Execution

- 4.1. Installation
 - a. System must be installed as per manufacturer's recommendation using method described in installation guide.
 - b. Place the heating cables and sensors in the surface material as per the installation guide.
 - c. Inspect the cable and controls upon receiving the shipment. Note any damage and ensure materials received match the order and shopping documents.
- 4.2. Tests
 - a. Refer the manufacturer's literature for requirements for testing and documenting cable resistance and insulation-to-ground readings.
 - b. Take test as outlined in the Installation manual.
 - c. If problems are discovered consult the manufacturer.
 - d. If unable to correct problems notify the engineer before proceeding with installation.
 - e. Keep record of all readings for inspection by the engineer or for submittal to the manufacturers to ensure a valid warranty.

5. Warranty

- 5.1. Manufacturer shall offer a 2-year, non-prorated warranty.

1.	Date	Desc.
----	------	-------

No: Date: Description:

Rep:

Project:

RX General Submittal

Drawing Title:

RX Constant Watt Specifications



11655 Crossroads Circle
Baltimore, Maryland 21220
Tel: 1-888-326-3677 Option: 3 Fax: 1 410-931-8256
www.Heating.Danfoss.us

The Contractor shall verify all job site dimensions all drawing, details & specifications.
The Contractor shall report any discrepancies, in writing to Danfoss prior to commencing with any work.

Date: **Quote No:**

March 2018

Drawn By: **Scale:**

N.T.S

Drawing No:

RX-2

RX-C Self Regulating Cable Specification

1. General

Supply and install a complete system comprised of heating cables, accessories, and controls for keeping roof eaves, gutters and downspouts from being clogged by ice and snow.

2. Material

- 2.1. Shall be Danfoss RX-C self-regulating heating cable.
- 2.2. The self-regulating heating cables shall consist of two (2) 16 AWG nickel-plated copper bus wires embedded in parallel in a radiation-cross linked polymer core that varies its power output in response to temperature all along its length, allows the heating cable to be cut in the field.
- 2.3. The heating cable shall be covered with a radiation cross-linked polyolefin dielectric jacket and protected by a tinned-copper braid and a polyolefin outer jacket.
- 2.4. The heating cable shall operate on line voltage of (select: 120V, 240V, 208V or 277V)
- 2.5. The heating cable shall have a nominal power output of 12W per foot in snow and ice and 5W per foot in air.
- 2.6. Power connection, end seal, splice, and tee connection kit, shall be able to be applied on site.
- 2.7. Heating cable circuit shall be protected by a ground fault device in accordance with section 426 of the NEC.
- 2.8. Shall be approved to applicable UL and CSA standards.

3. System Controls

Option 1: Automatic Snow Controller
The system shall be controlled by Danfoss GX850 control panel with external digital temperature and moisture sensors either directly or through an appropriate contractor.

- 1.1. Automatic Snow Controller shall be microprocessor based to provide effective, economical, automatic control.

- 1.2. Automatic Snow Controller shall have dual zone capability.

- 1.3. Automatic Snow Controller shall have an adjustable timer providing up to ninety minutes of system operation after snowfall ceases for complete melting.

- 1.4. Automatic Snow Controller shall have the following modes.
 - a. Automatic
 - b. Constant OFF
 - c. Constant ON (manual timer)

- 1.5. Automatic Snow Controller shall have adjustable parameters
 - a. Melting Temperature (32°F to 49°F)
 - b. Timer (5 to 95 minutes)

- 1.6. Automatic Snow Controller shall be able to indicate the actual temperature and moisture levels for sensors.

- 1.7. Automatic Snow Controller shall have info-button for help/information.

- 1.8. Automatic Snow Controller shall have self-doagnosis program, which will detect faults and give them an alarm.

- 1.9. Automatic Snow Controller shall have individual LEDs to provide indication of alarm and heater operation.

- 1.10. Automatic Snow Controller shall be capable of accepting four roof sensors.

- 1.11. Automatic Snow Controller shall have multi-language capabilities (English, Spanish, and French)

- 1.12. Sensors shall include 50' lead.

Option 2: Snow Switch Control
The system shall be controlled by Danfoss DS-8 temperature and moisture sensor either directly or through an appropriate contractor.

- 2.1. DS-8 shall be microprocessor-based to provide effective, economical, automatic control.

- 2.2. DS-8 shall have an adjustable timer providing up to ninety minutes of system operation after snowfall ceases for complete melting.

- 2.3. DS-8 Snow Controller shall have the following modes.
 - a. Manual ON
 - b. Automatic
 - c. Stanby/Reset

- 2.4. DS-8 Snow Controller shall have adjustable parameters
 - a. Melting Temperature (34°F to 44°F)
 - b. Timer (30 to 90 minutes)

- 2.5. DS-8 Snow Controller shall have two sensors: Moisture and Temperature.

Option 3: Thermostat
The system shall be controlled by an ambient sensing thermostat Danfoss 088L3422 either directly or through an appropriate contractor.

Option 4: Manual Switch
The system shall be controlled by a manual switch either directly or through an appropriate contractor.

4. Execution

- 4.1. Installation
 - a. The heating cable should be laid in gutters; shall be suspended in downspouts either as a loop or a single length and held in place by a downspout hanger (edge protection plate); and shall be attached to the roof using the roof clips.
 - b. The heating cable shall be protected from damage and installed according to manufacturer's instructions.
 - c. Inspect the cable and controls upon receiving the shipment. Note any damage and ensure materials received match the order and shopping documents.

- 4.2. Tests
 - a. After installation, the dielectric jacket's insulation resistance from the conductors to the shield shall be greater than 1000 mega-ohms.

5. Warranty

- 5.1. Manufacturer shall offer a 2-year, non-prorated warranty.

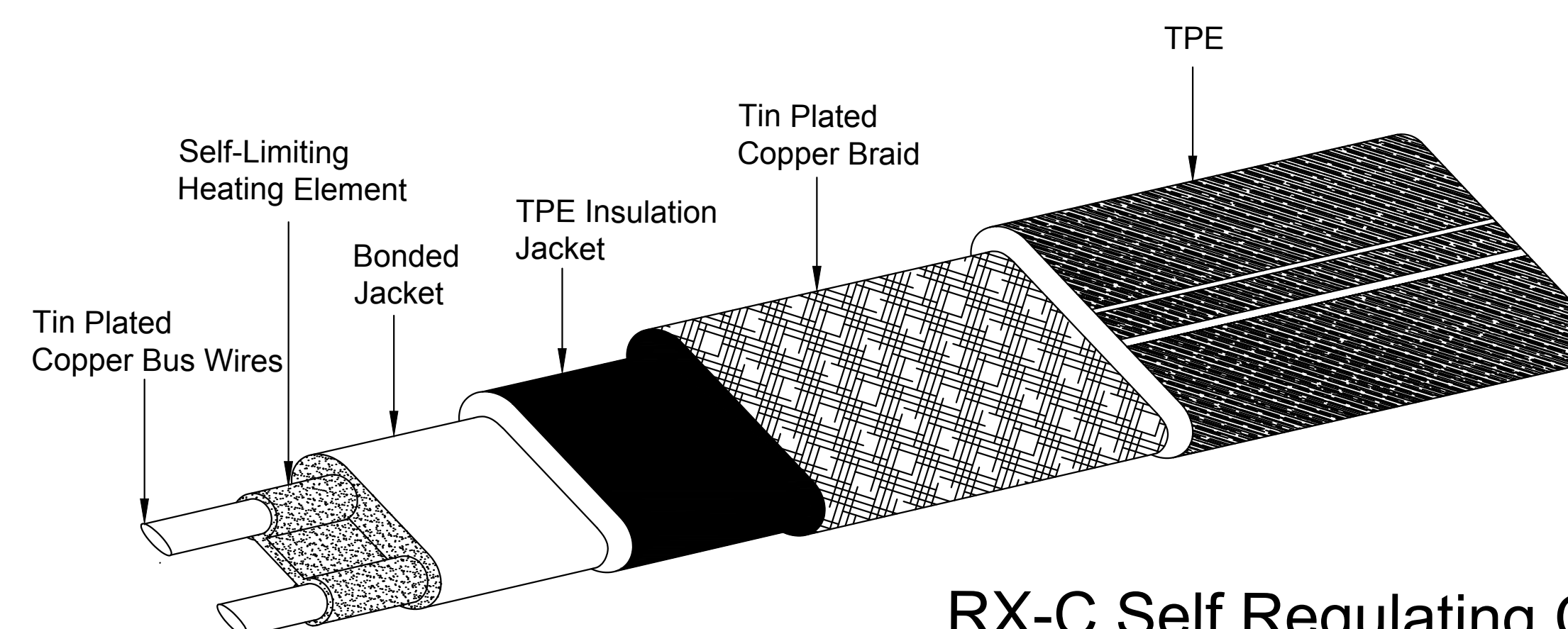

RX-C Self Regulating Cable

1.	Date	Desc.
No:	Date:	Description:
Rep:		
Project:		
RX General Submittal		
Drawing Title:		
RX-C Self Regulating Specifications		
		
11655 Crossroads Circle Baltimore, Maryland 21220 Tel: 1-888-326-3677 Option: 3 Fax : 1 410-931-8256 www.Heating.Danfoss.us		
The Contractor shall verify all job site dimensions all drawing, details & specifications. The Contractor shall report any discrepancies, in writing to Danfoss prior to commencing with any work.		
Date:	Quote No:	
March 2018		
Drawn By:	Scale:	
	N.T.S	
Drawing No:		
RX-3		



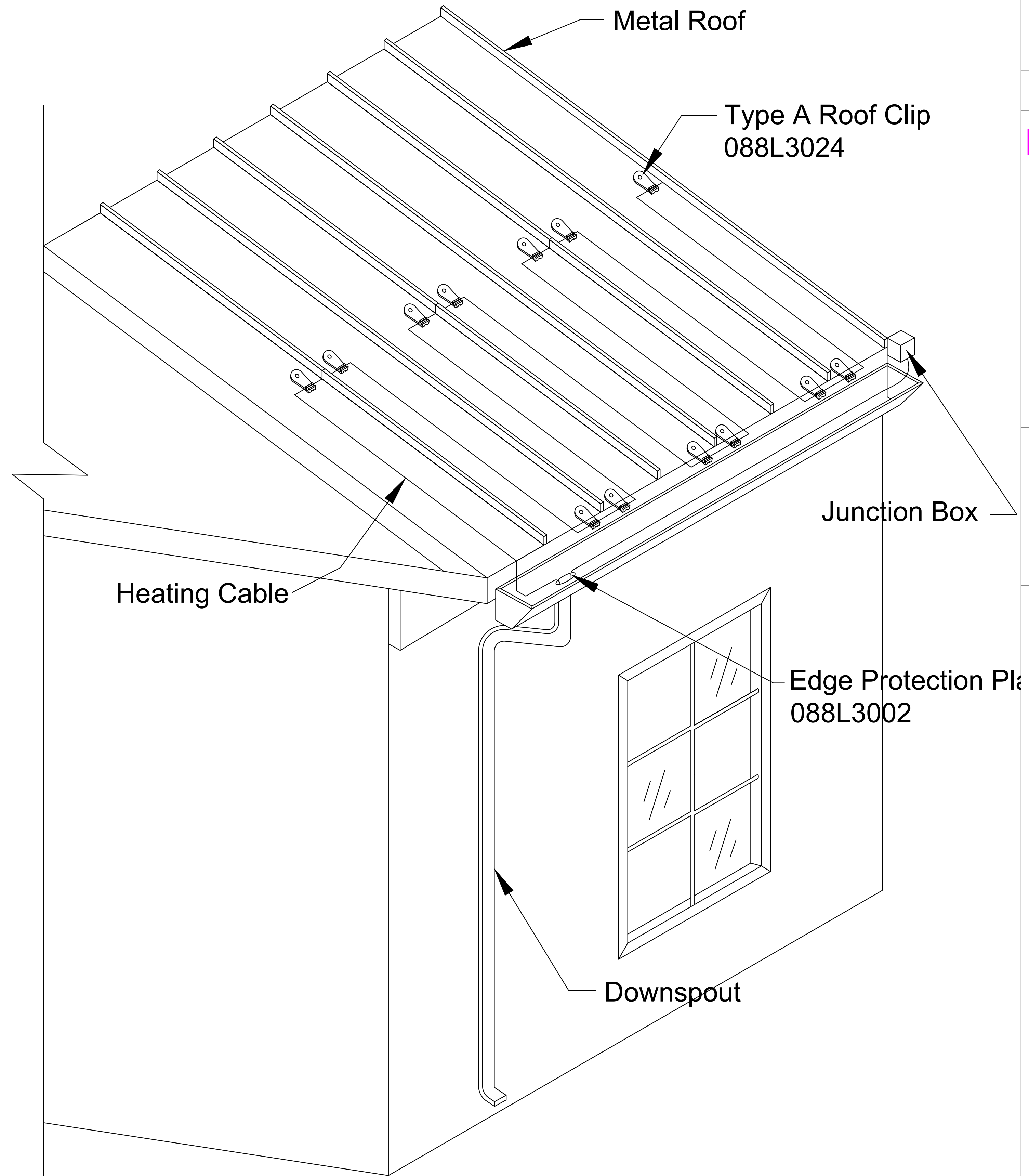
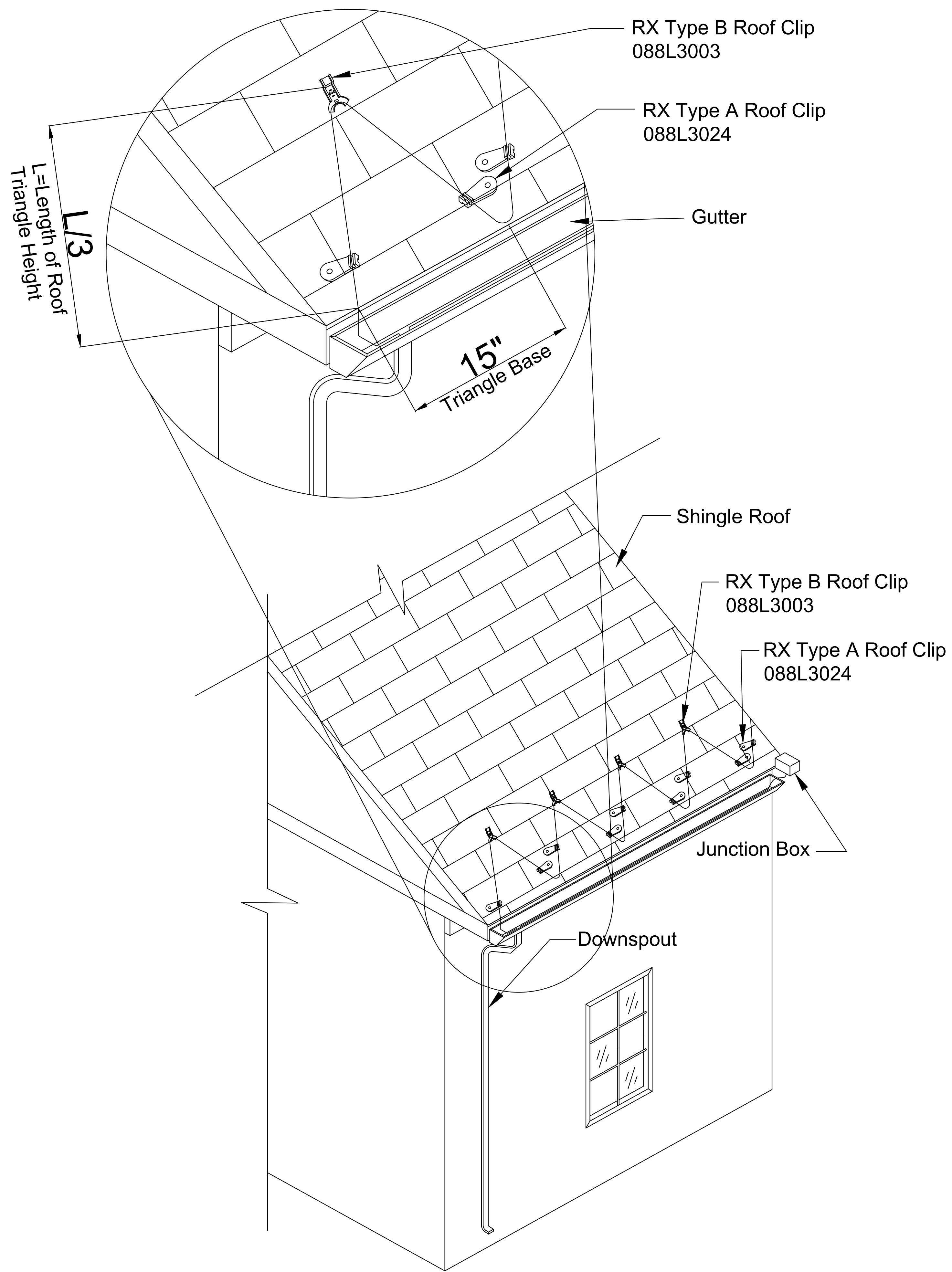

1.	Date	Desc.
No:	Date:	Description:

Rep:

Project:
RX General Submittal

Drawing Title:
Typical Roof Install



11655 Crossroads Circle
 Baltimore, Maryland 21220
 Tel: 1-888-326-3677 Option: 3 Fax: 1 410-931-8256
www.Heating.Danfoss.us

The Contractor shall verify all job site dimensions all drawing, details & specifications.
 The Contractor shall report any discrepancies, in writing to Danfoss prior to commencing with any work.

Date:	Quote No:
March 2018	

Drawn By:	Scale:
	N.T.S

Drawing No:
 RX-4

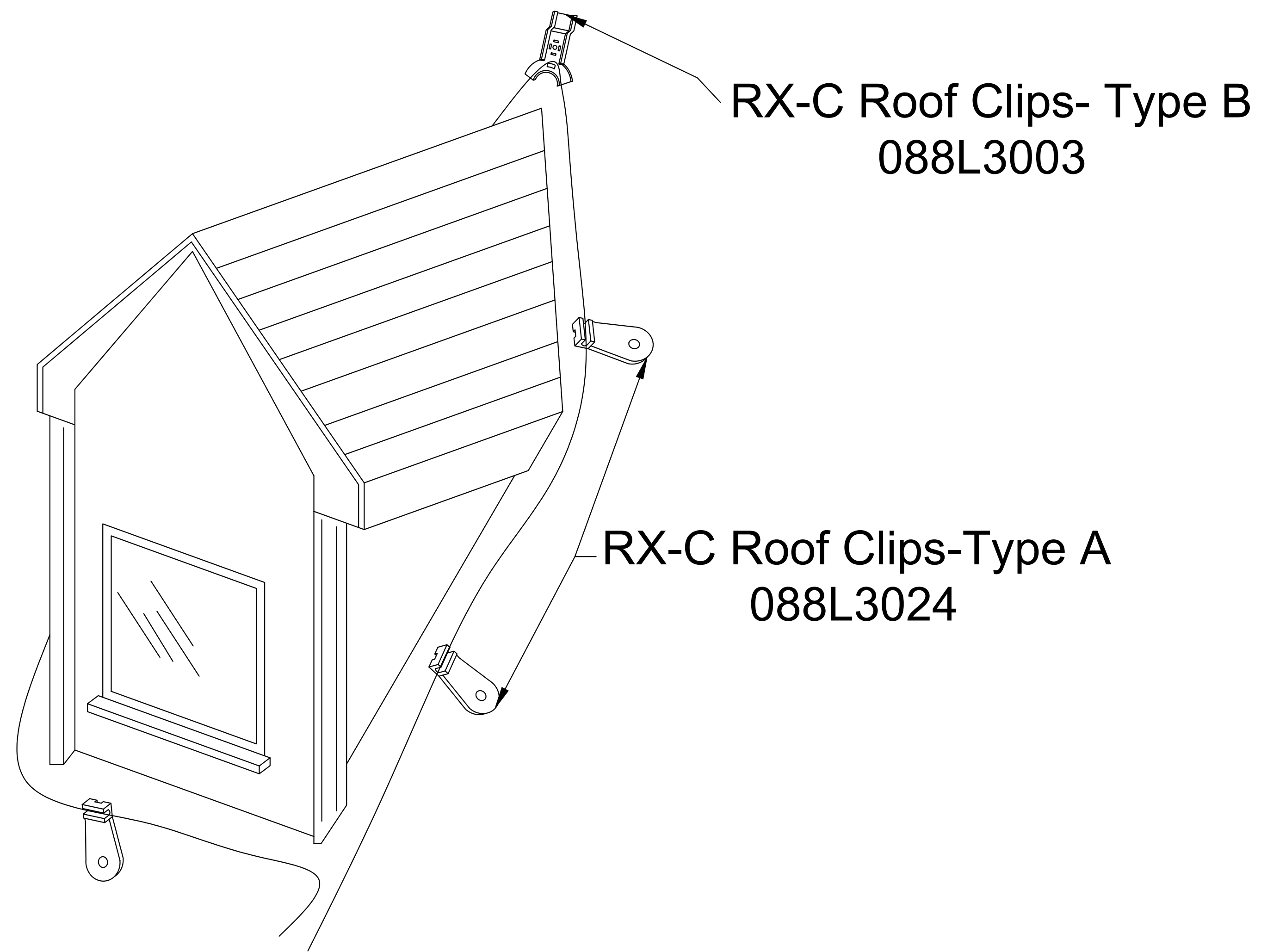

Detail:1 Dormer Pattern
RX-5

RX-C Roof Clips- Type B
088L3003

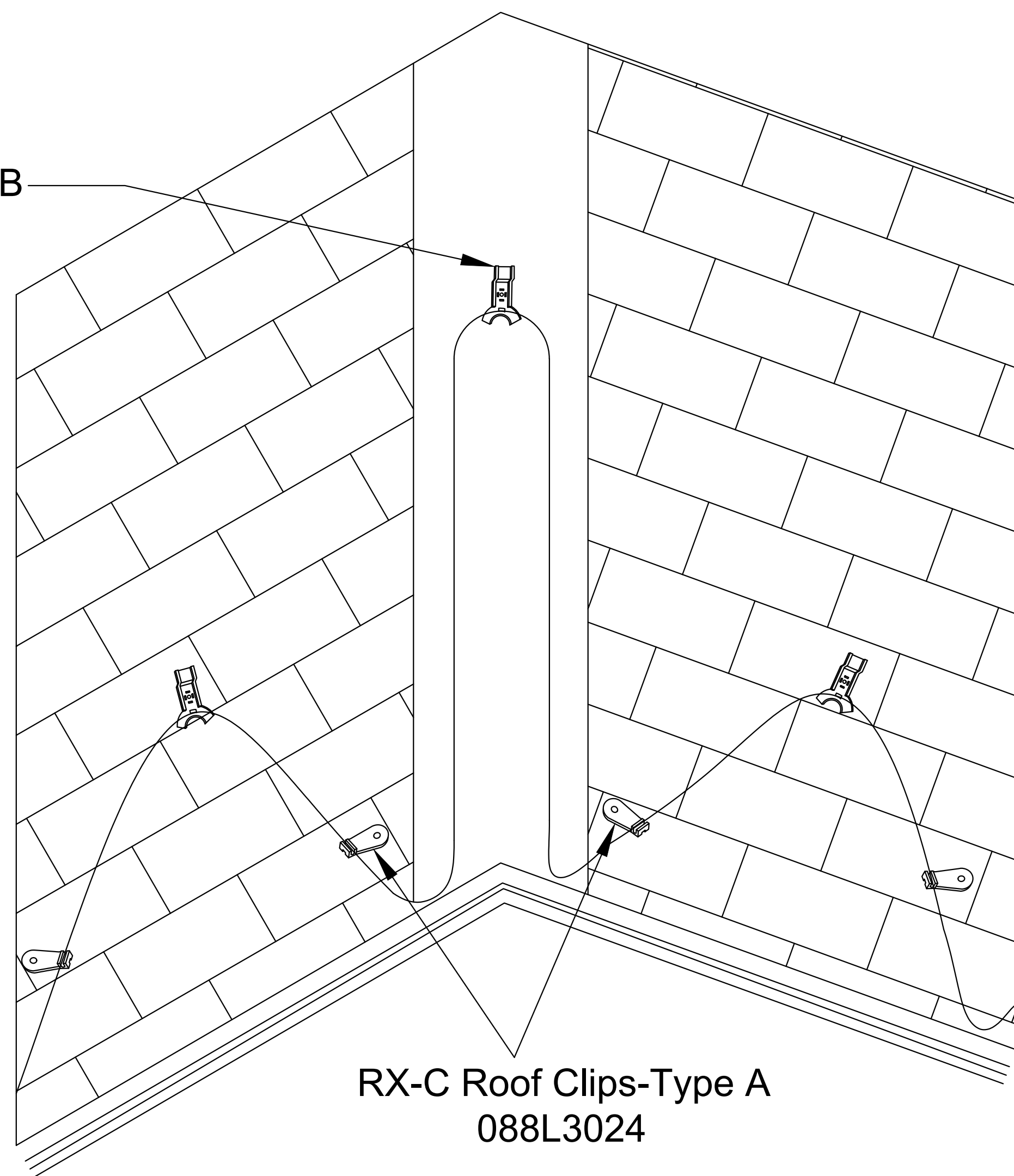

Detail:2 Valley Pattern
RX-5

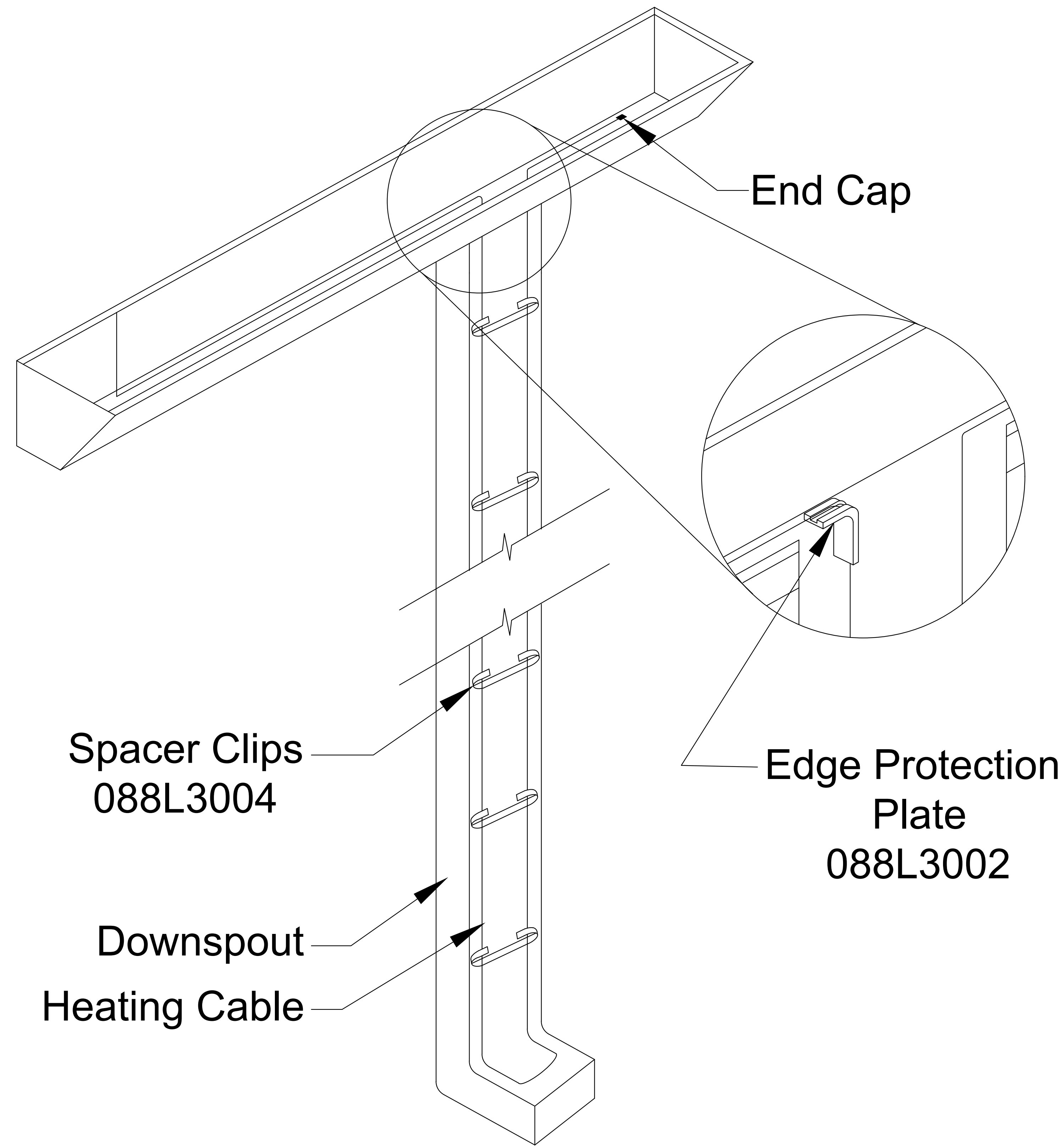

Detail:3 Downspout Pattern
RX-5

1.	Date	Desc.
No: Date: Description:		
Rep:		
Project:		
RX General Submittal		
Drawing Title:		
Detail Typical Roof Install		
		
11655 Crossroads Circle Baltimore, Maryland 21220 Tel: 1-888-326-3677 Option: 3 Fax : 1 410-931-8256 www.Heating.Danfoss.us		
The Contractor shall verify all job site dimensions all drawing, details & specifications. The Contractor shall report any discrepancies, in writing to Danfoss prior to commencing with any work.		
Date:	Quote No:	
March 2018		
Drawn By:	Scale:	
	N.T.S	
Drawing No:		
RX-5		



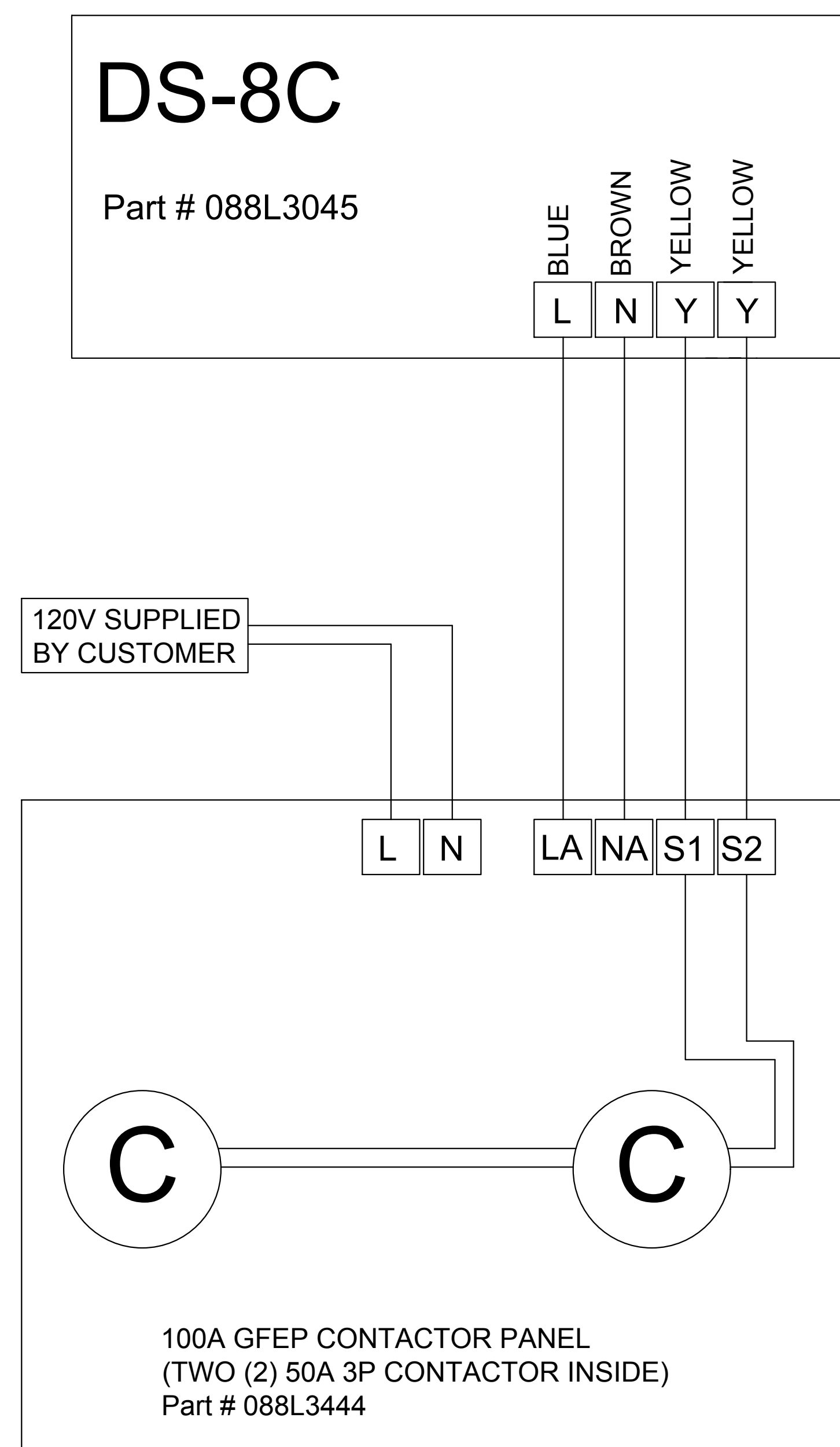
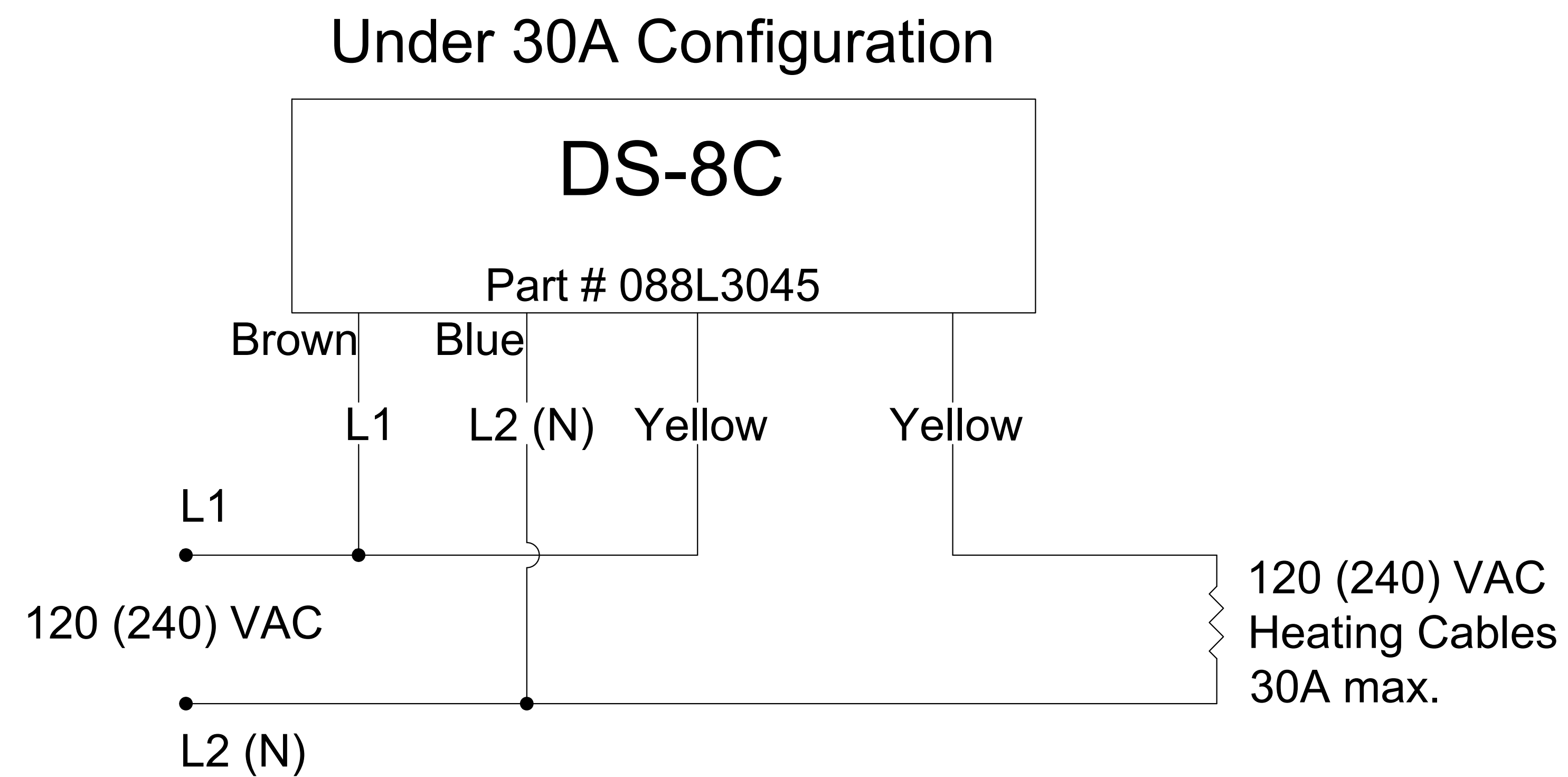

Moisture Sensor Mounting & Termination

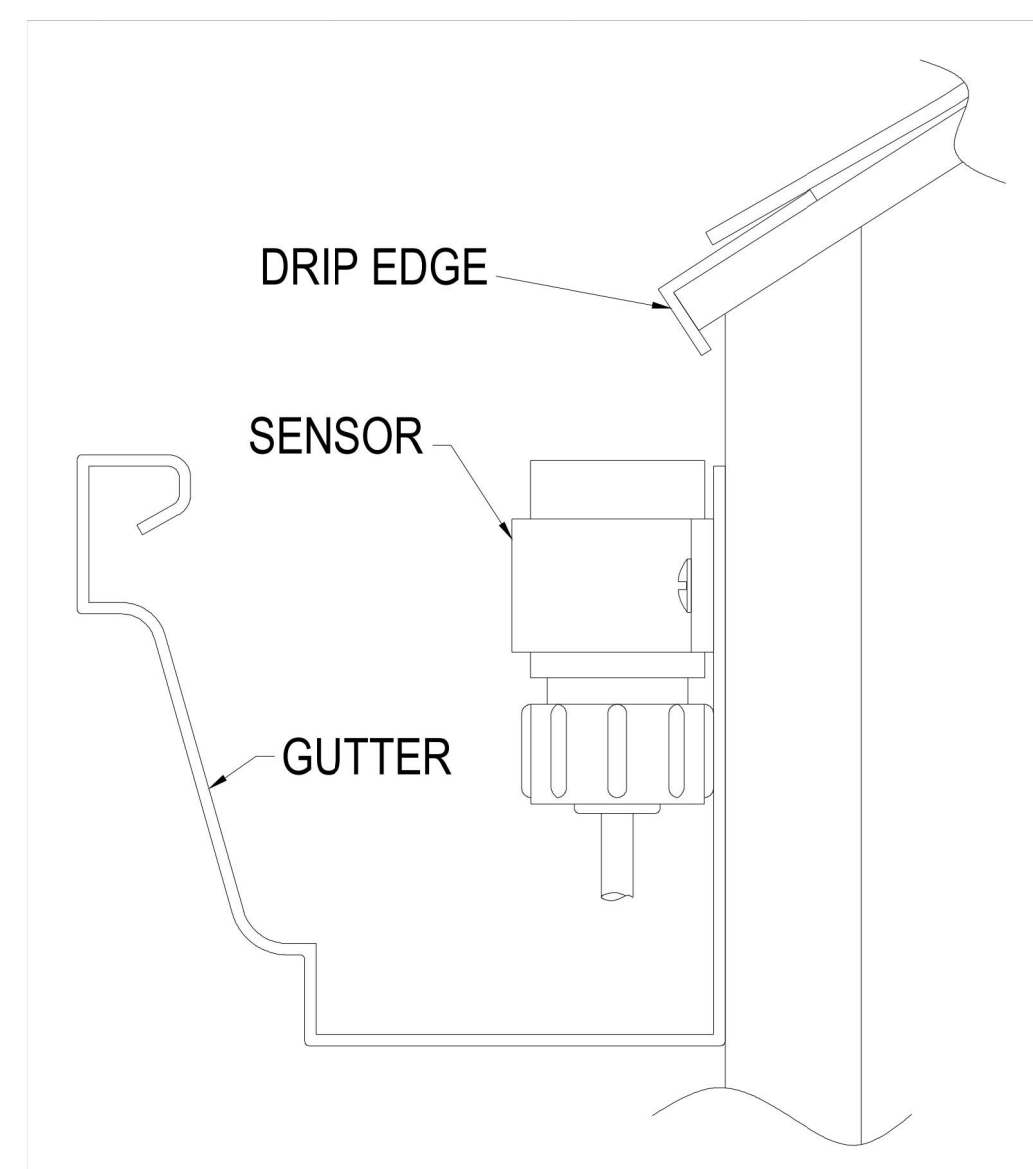

The DS-8C enclosure and moisture sensor must be mounted outdoors. The remote DS-8C moisture sensor may be mounted in a number of ways depending on the application. The unit operates at low voltage and can withstand immersion in water. For roof and gutter deicing applications the sensor head may be mounted in the gutter against the fascia board with a 1" "C"-style conduit clamp. Allow part of the sensor grid to be exposed to snowfall. This allows the sensor to initially trigger when snow starts falling and remain triggered as long as the roof/gutter heater continues to drip melted snow buildup from the roof edge when temperatures are below freezing. Detection can also be achieved by installing the sensor head near the top of the downspout using a 1" conduit hanger and mounting plate. As water is melted in the gutter it will run down the downspout, hitting and retriggering the sensor.

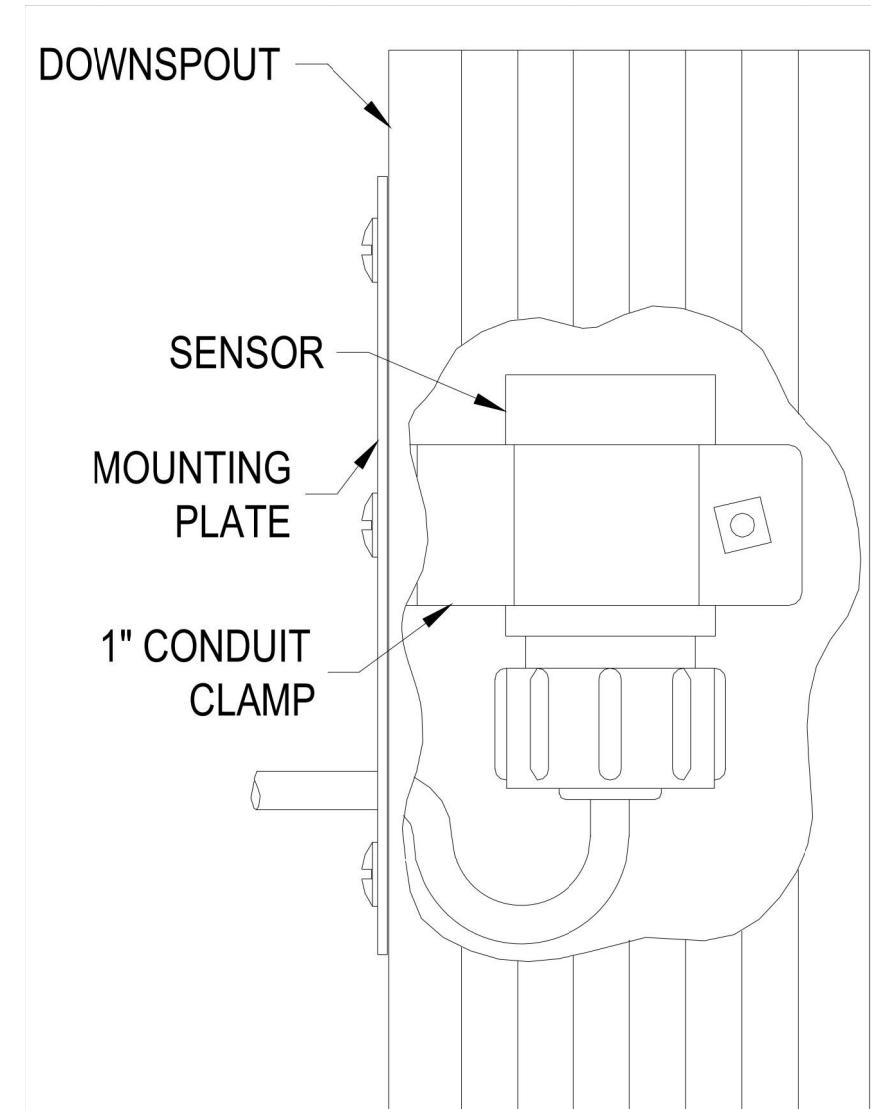

Ten feet of cable is pre-terminated to the sensor head. This cable may be shortened on the controller end as required. **Do not add additional cable to the interface.** Erratic operation may result. Strip the outer insulation and shield from the cable and terminate each conductor following the color code printed on the circuit board. The bare drain wire should be installed into the terminal marked "S" for Shield. Two cable ties are also included. Wrap these ties securely around the cable in the enclosure to provide additional strain relief between the flexible enclosure gland and the free end of the cable.

DS-8C

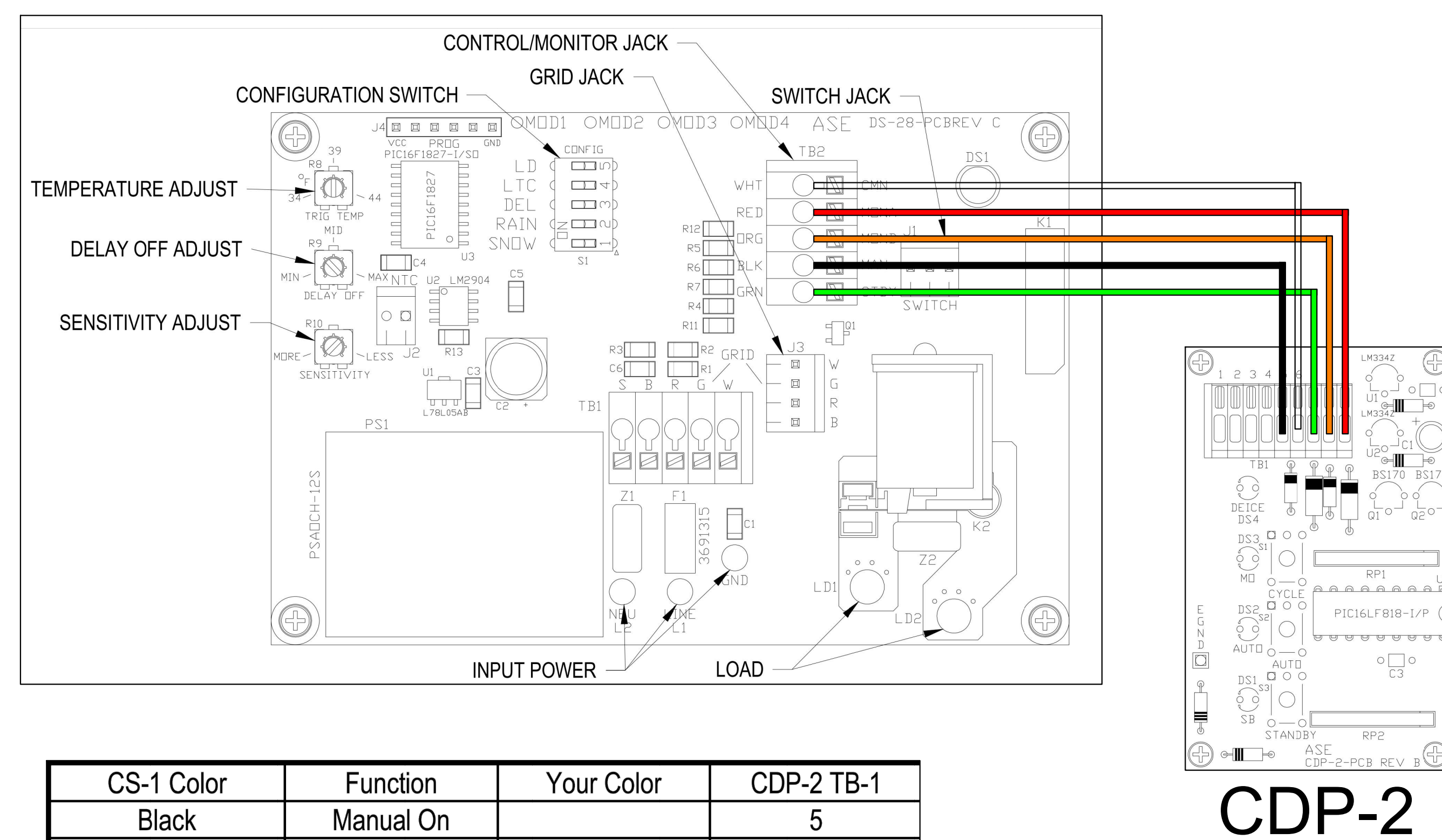

CS-1 Color	Function	Your Color	CDP-2 TB-1
Black	Manual On		5
White	Return		6
Green	Standby/Reset		7
Orange	Deice On Mon		8
Red	Deice On Mon		9

- Note:
- The cable conductors must be tinned, stranded, minimum 22AWG copper. Overall shielding is required
 - The CDP-2 can be installed as much as 500 feet away from the snow sensor if proper cable is used.

1. Date Desc.
No: Date: Description:

Project:
RX General Submittal
Drawing Title:
DS-8C Typical Application



11655 Crossroads Circle
Baltimore, Maryland 21220
Tel: 1-888-326-3677 Option: 3 Fax: 1 410-931-8256
www.Heating.Danfoss.us

The Contractor shall verify all job site dimensions all drawing, details & specifications. The Contractor shall report any discrepancies, in writing to Danfoss prior to commencing with any work.

Date: Quote No:

March 2018

Drawn By: Scale:

N.T.S

Drawing No:

RX-6

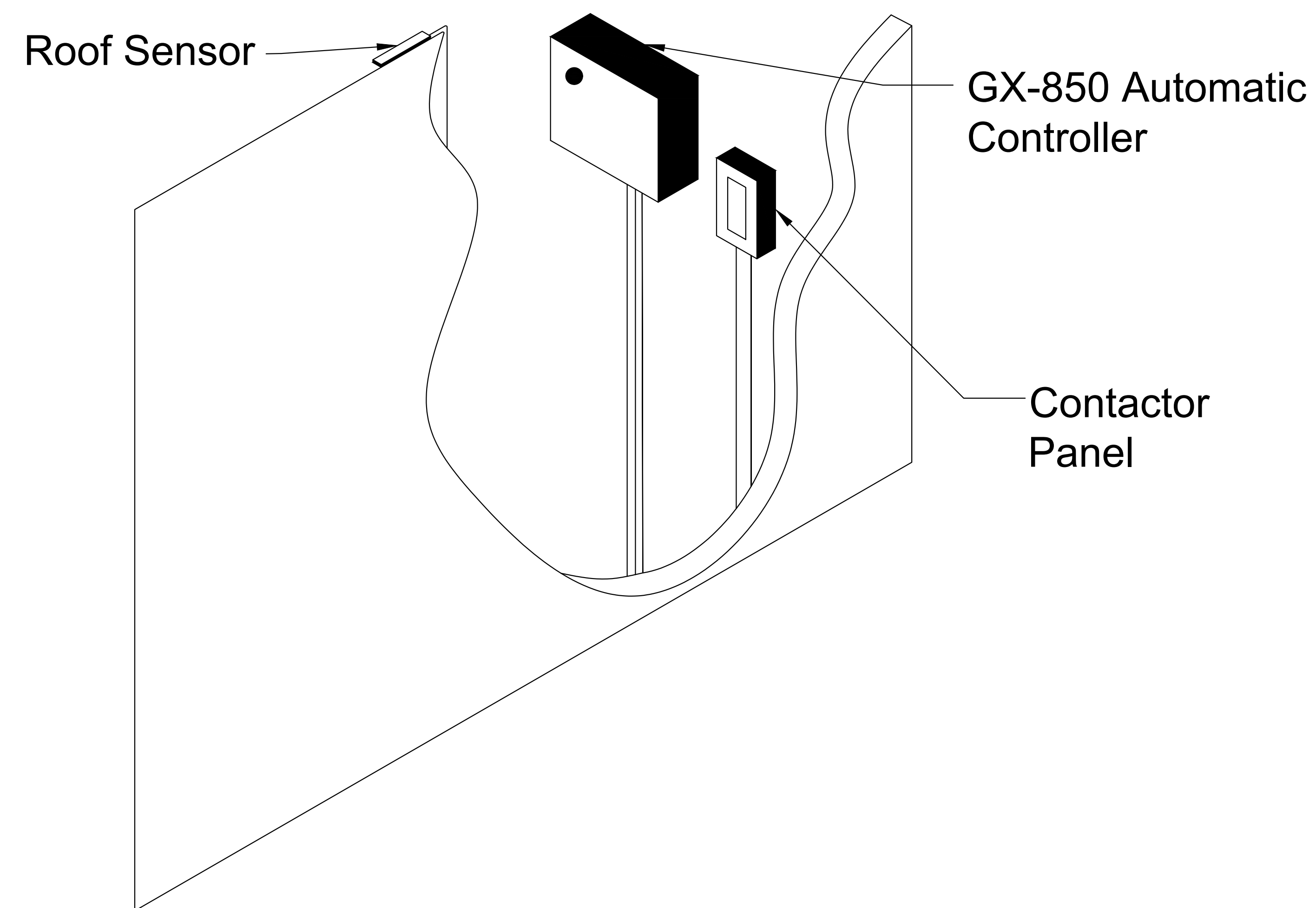
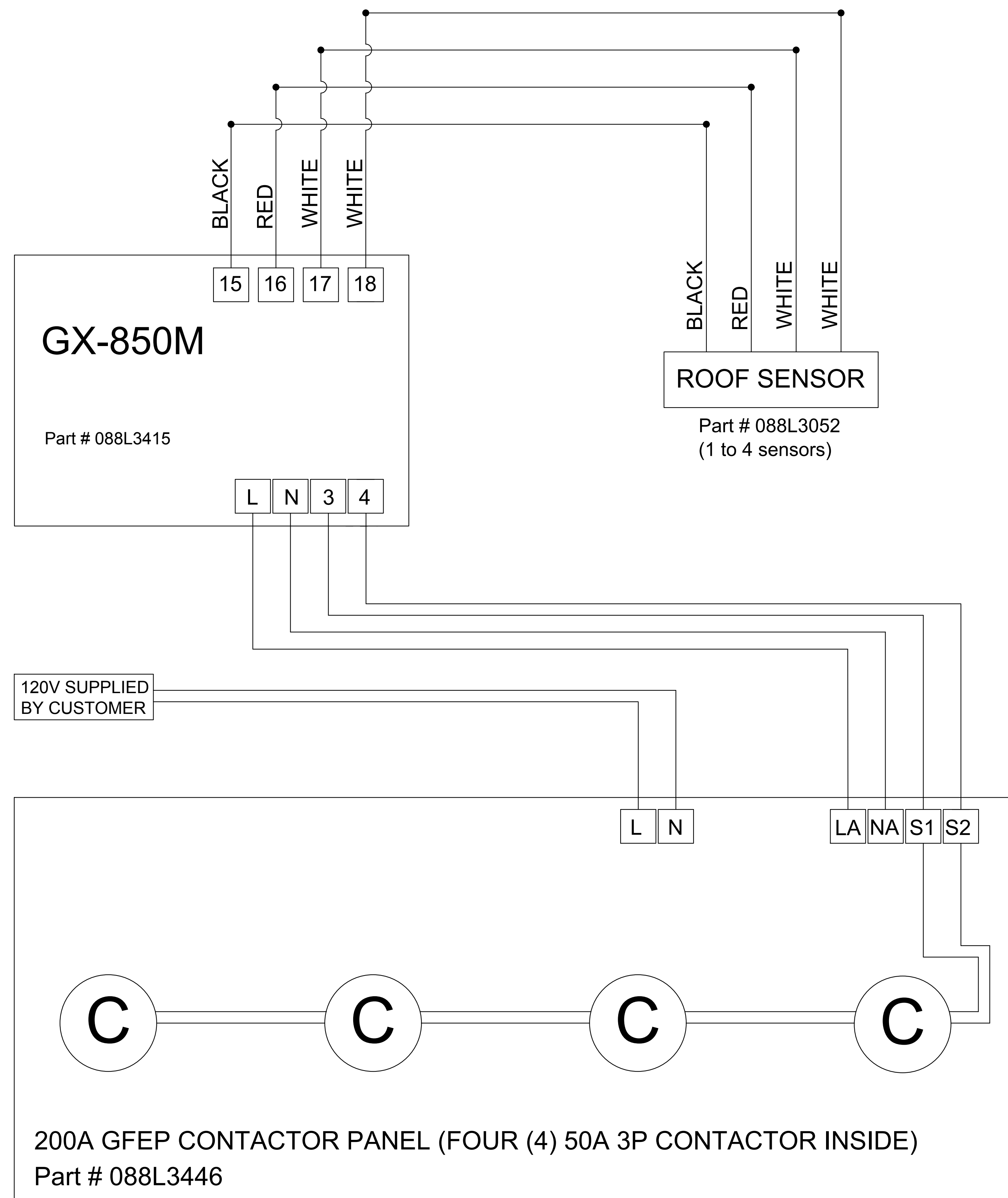

1.	Date	Desc.
No:	Date:	Description:

Rep:

Project:
RX General Submittal

Drawing Title:
GX-850M Typical Application



11655 Crossroads Circle
Baltimore, Maryland 21220
Tel: 1-888-326-3677 Option: 3 Fax: 1 410-931-8256
www.Heating.Danfoss.us

The Contractor shall verify all job site dimensions all drawing, details & specifications.
The Contractor shall report any discrepancies, in writing to Danfoss prior to commencing with any work.

Date:
March 2018

Quote No:

Drawn By:

Scale:
N.T.S

Drawing No:
RX-7

Note: Sensor wire cannot be extended.

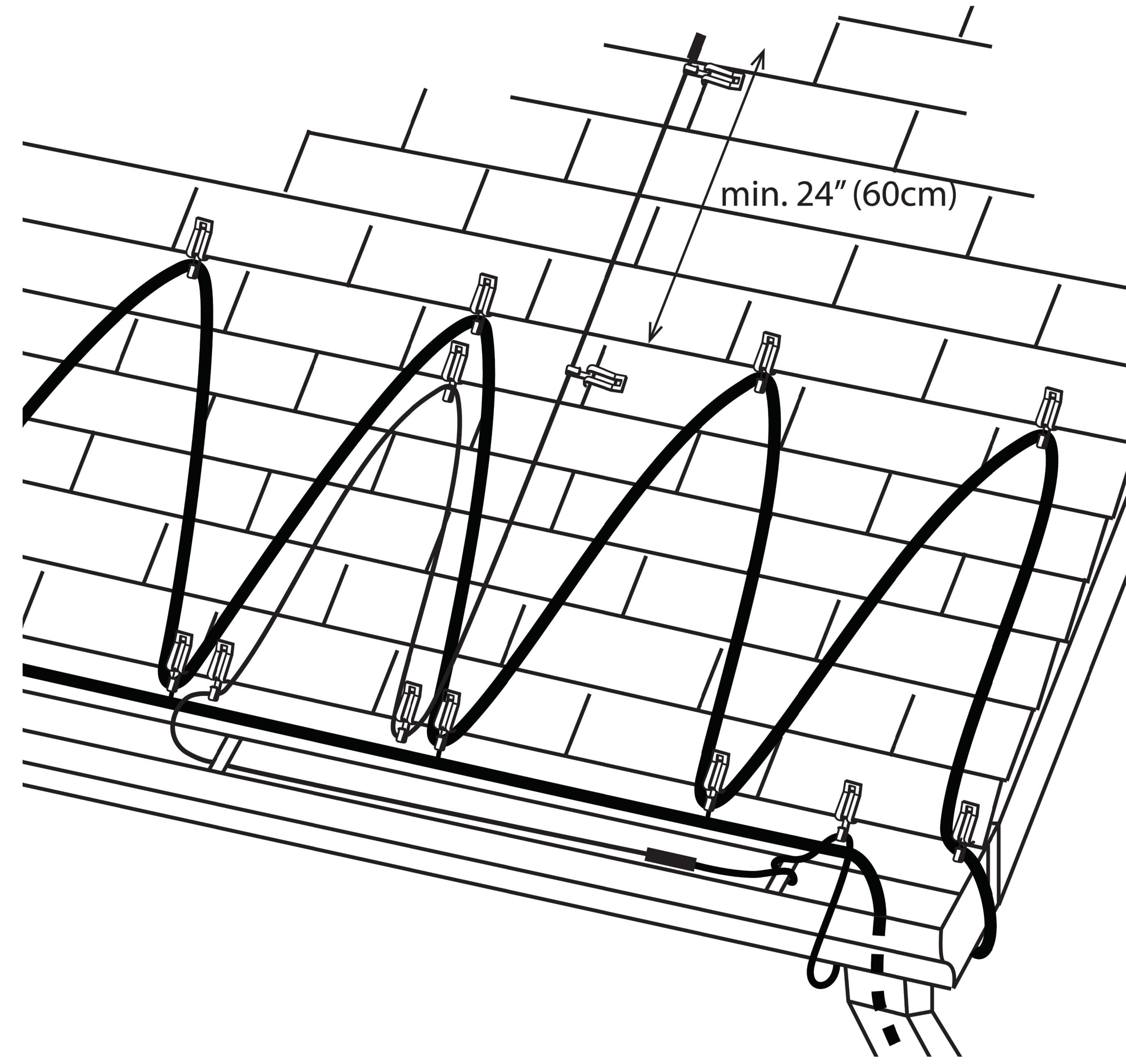

1.	Date	Desc.
No: Date: Description:		
Rep:		
Project:		
RX General Submittal		
Drawing Title:		
RX-1200 Typical Application		



11655 Crossroads Circle
 Baltimore, Maryland 21220
 Tel: 1-888-326-3677 Option: 3 Fax: 1 410-931-8256
www.Heating.Danfoss.us

The Contractor shall verify all job site dimensions all drawing, details & specifications.

The Contractor shall report any discrepancies, in writing to Danfoss prior to commencing with any work.

Date:

March 2018

Quote No:

Drawn By:

Scale:

N.T.S

Drawing No:

RX-8

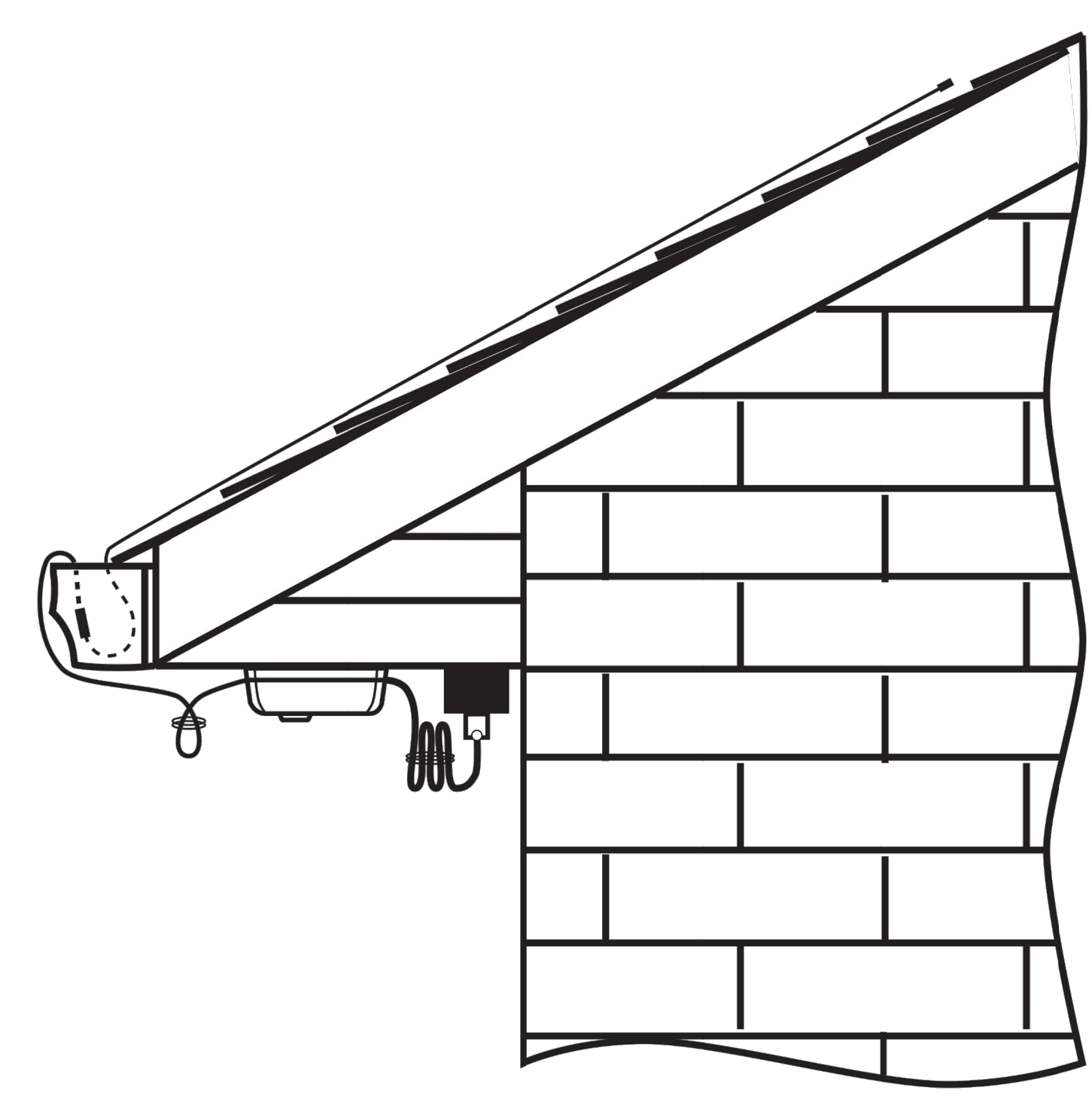
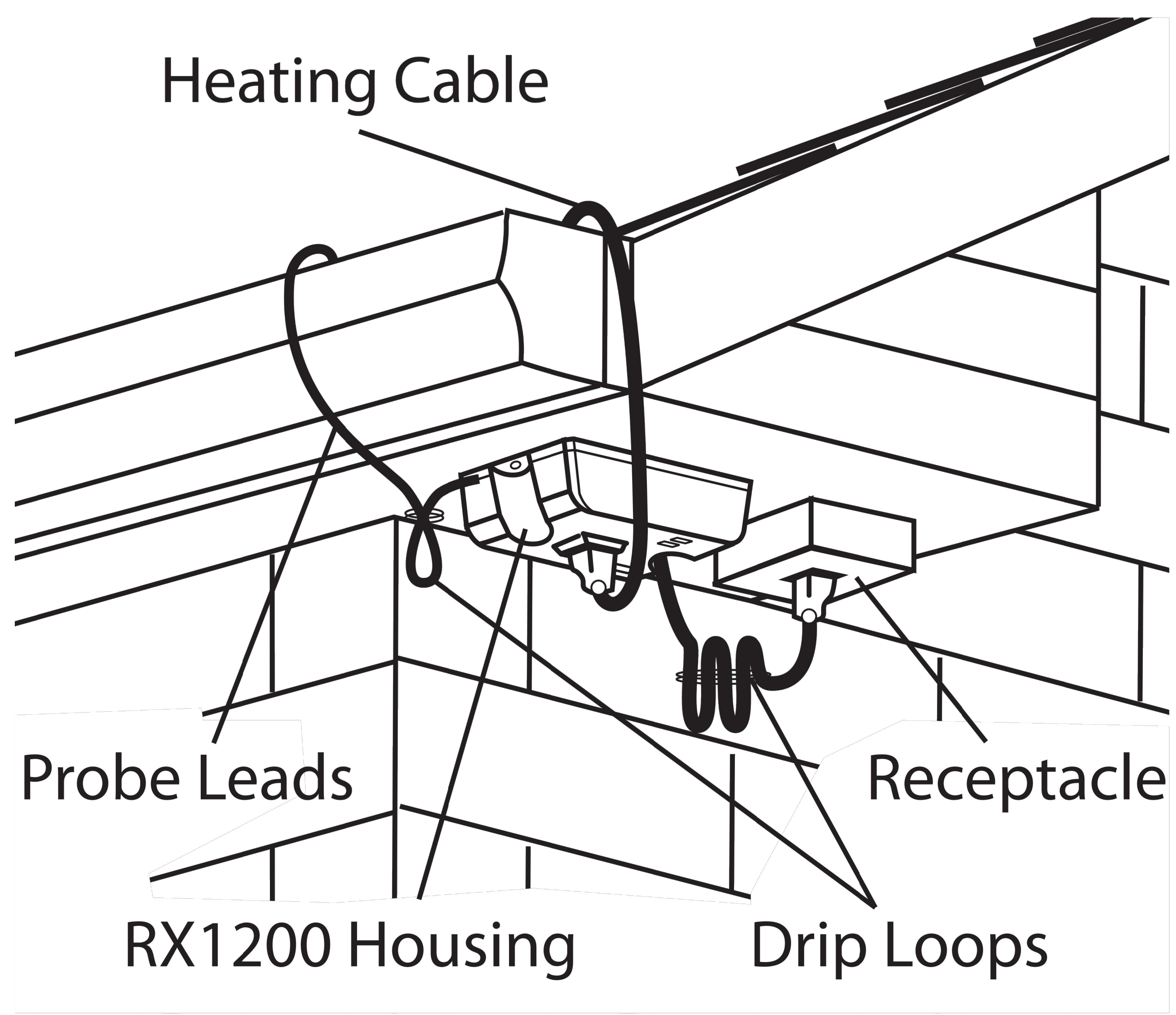

Sensor Wire installation with gutter

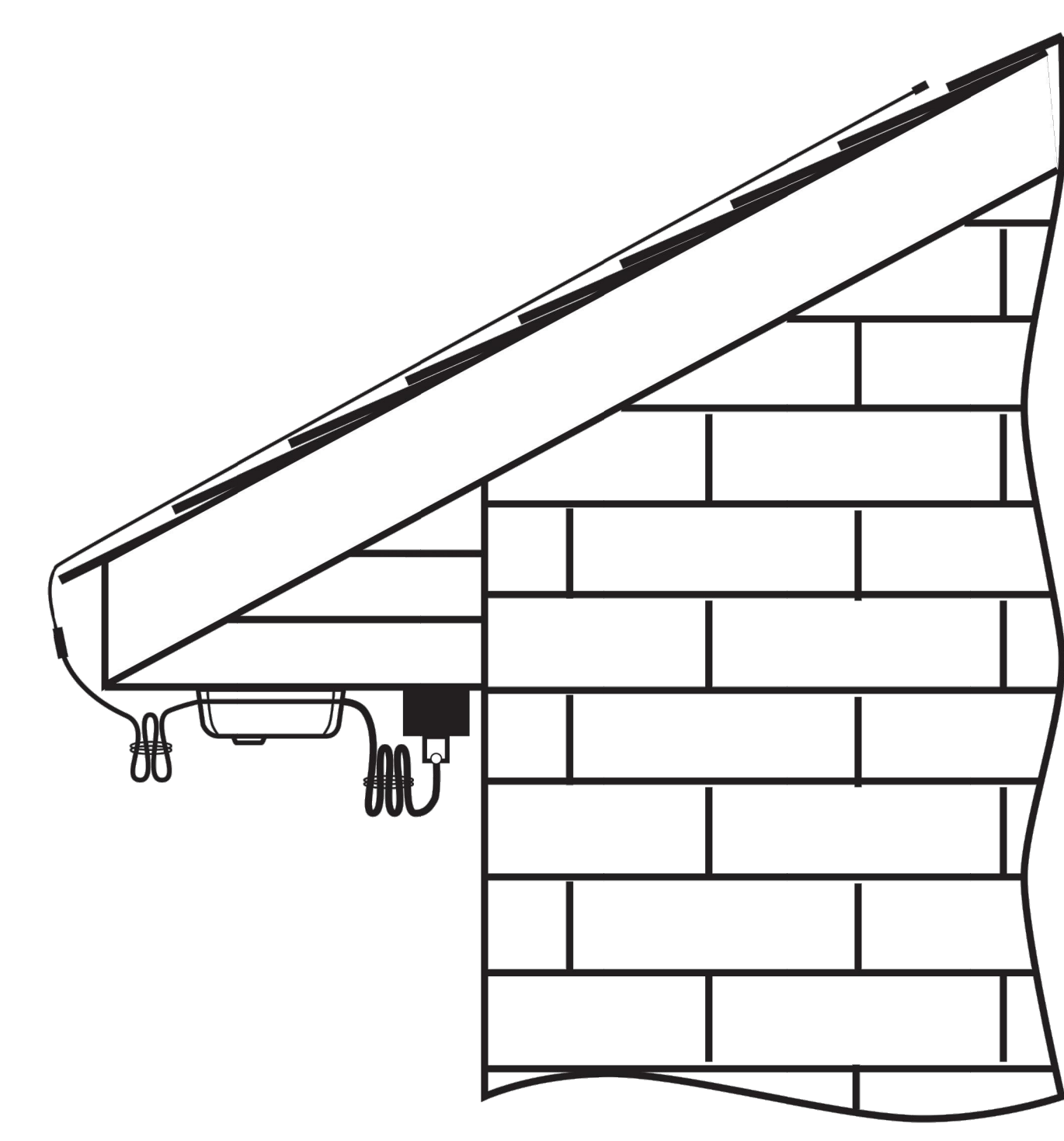

Sensor Wire installation without gutter