

Case study | VACON® NXP DC/DC Converter

# Flexible DC backup **protects** Russian power plant

Reliable power supply smooths out the briefest of voltage drops

**A large Russian power plant vulnerable to main supply interruptions is now equipped with VACON® NXP DC/DC Converters for industrial DC backup. The system ensures uninterrupted power plant operation during even the briefest of supply voltage drops.**

Stoppages in the power plant, even for just seconds, result in process failure and financial losses. Therefore, a preventive measure against power outages was required.

The contractor IC-ART chose an industrial DC backup system from Danfoss Drives to ensure a fully reliable but also flexible system to maintain power supply under all circumstances.



### Industrial DC backup for boiler fans

Using water-cooled drives in a “step down – step up” configuration with medium voltage motors, IC-ART and Danfoss Russia developed an industrial DC backup system to ensure reliable operation even during voltage drops in the mains. The powerful 1.2 MW system is also known as an uninterruptable motor drive (UMD) system and uses two 690 V air-cooled VACON® NXP DC/DC Converters, as shown in Figure 1.

A series of 1200 kW boiler fans supply up to 10 seconds operation in the event of main grid failure. A single battery storage is connected through the two separate DC/DC converters to 4 drives.

- Two 200 kW drives serve the forced-draft fans and share a common VACON® NXP DC/DC Converter
- Two 400 kW drives serve the exhaust fans and also share a common VACON® NXP DC/DC Converter

### Streamlined commissioning and service

This solution is streamlined, comprising only a few elements, simple connections, and integrated Danfoss application inside, to ensure simple commissioning and service procedures. IC-ART offers a range of industrial DC backup systems known as uninterruptable motor drives (UMDs). These UMDs are flexible because they cater to

- different topologies
- different types of AC drive
- different energy storage technologies
- diverse layouts
- the use of existing batteries if desired

### Danfoss Drives Russia

Project managers, R&D engineers and the technical support team at Danfoss Drives Russia support customer projects with these services:

- Dimensioning the system
- Technical support
- Application software development
- Solution delivery management
- Commissioning support
- 50+ service partners

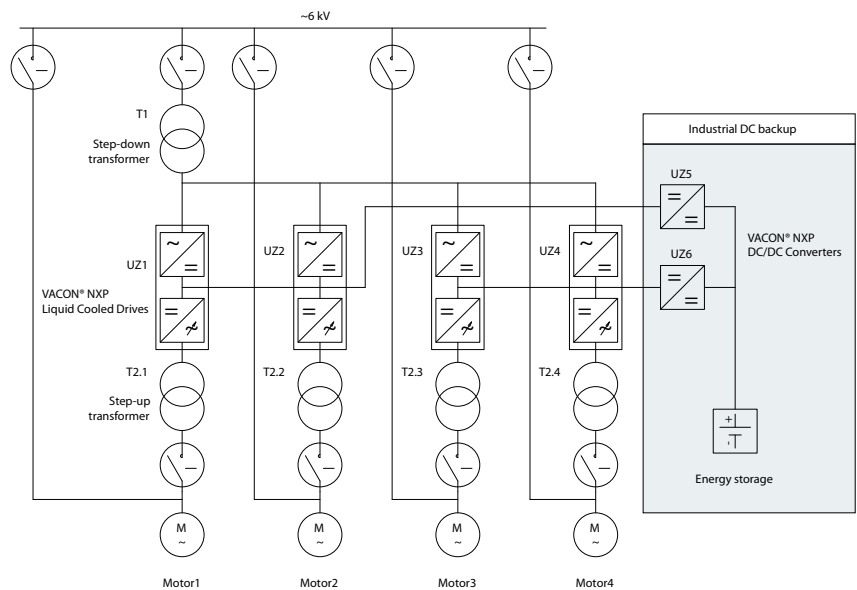

Figure 1: Schematic diagram of the power plant industrial DC backup system



Igor Zobov, General Director, IC-ART



Alexandr Melentiev, IC-ART

### IC-ART

#### The Engineering Center Automation of Resource-saving Technologies

known as IC-ART, is located in Saint Petersburg, Russia. The team comprises 25 employees and has a long history of cooperation with Danfoss, stretching back to 1999.

IC-ART offers engineering design of AC drives and automation systems for low- and medium-voltage applications, uninterruptable motor drive (UMD) systems, and active filters for use in harmonics and reactive power compensation, as well as maintenance and repair services.

Its business areas include power generation, oil and gas, and marine and offshore industries. To date, IC-ART has completed more than 700 drive automation system installations.

[www.ic-art.ru](http://www.ic-art.ru)