

ENGINEERING
TOMORROW

Danfoss

Product Brochure

Airflex[®] Coremo hydraulic brakes and accessories

Safe, reliable, hydraulic braking solutions



VICKERS
by Danfoss

A legacy of meticulous design, **high-quality components and reliable production**

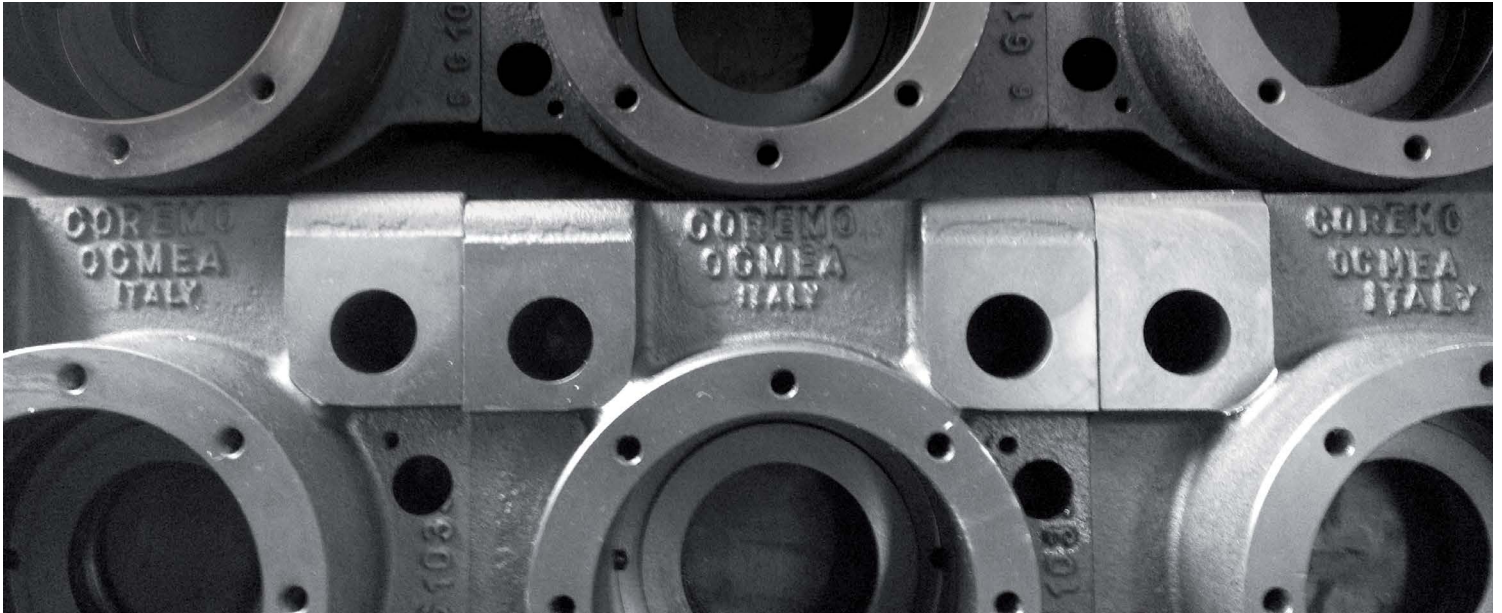

Our services

Drawing on a long tradition in the manufacture of brakes and clutches, Danfoss and Coremo Ocmea have partnered to become a global leader in safe, reliable solutions for industrial, marine, oil and gas, energy, and entertainment sector applications. We offer a broad range of hydraulic caliper brakes, as well as services with a high degree of customization.

Design services

Our goal is to design and provide a braking solution suitable for your specific application, through a process characterized by continuous research and development, cost optimization, customization and FEM analysis.

Products

A wide range of brakes and accessories are available and verified by both internal and external quality tests. Our product range includes hydraulic brakes, pneumatic brakes, multi-disc brakes, water-cooled brakes, air-cooled brakes, customized brakes, clutches, hydraulic power units, discs, couplings, and accessories.

Supply chain services

A large network of sales representatives, distributors, and support staff allows us to meet our customers' needs and provide flexible service worldwide. We offer quick response time, stocked parts, short delivery terms, and customized labeling.

After-sales support

Any post-sales help, questions, or special needs are quickly and thoroughly addressed by our specialists. In addition to technical support, we offer dedicated training, spare parts availability, and product reconditioning.

A solution for the safety requirements of a **wide range of industrial applications**

Coremo hydraulic brakes

Hydraulic thruster caliper brakes

Oil applied



Spring applied



The certified, tested, and inspected SG iron levers are designed to withstand the stresses generated during dynamic braking, while the steel thruster is calculated to support pressures of over 100 bar. The lining pads are produced using friction materials compliant with the relevant standards on safety and toxic substances.

Our brakes can be supplied complete with wear indicator and on/off switch. Operating temperatures range from -20 °C to +200 °C.

Direct hydraulic brakes

Oil applied



Spring applied



Brake bodies — in cast iron or steel — are designed to withstand high pressures and prevent oil leaks. Brake operating temperatures range from -20 °C to +200 °C, with solutions available for -40 °C. ID direct hydraulic brakes are supplied with wear indicators. Inductive on/off positioning sensors can be mounted upon request.

The steel and SG iron bodies are certified, tested and inspected. ID brakes are designed to withstand the stresses generated during dynamic braking, while the steel bodies are calculated to support pressures of over 200 bar.

HYDRAULIC POWER PACKS



Our hydraulic power packs are engineered to complete the braking system and make it more efficient, safe, and suitable for the specific application. All power units have redundant return valves, an oil temperature control system, and a hand-operated system to be used in case of power failure. The units are available for both oil-applied and spring-applied hydraulic brakes.

The size of the tank, pump, and motor are selected based on the type and quantity of brakes to be powered. Distances, braking time, reaction time, piping, unit positioning, temperature, and certifications are also considered in specifying the correct power pack.



Hydraulic brakes

Our hydraulic brakes cover a clamping force ranging from 10,000 N to 750,000 N.

Custom paint and treatments are available to meet specific customer needs or environmental conditions. For offshore applications, our brakes meet ISO 12944 class C5M corrosion protection to reduce maintenance and life-cycle costs.

Special attention is paid to the selection and combination of different materials and their treatments to minimize the electrolytic effect, which can produce unexpected oxidation in saltwater environments.

Special steel and treatments are used in low-temperature applications.

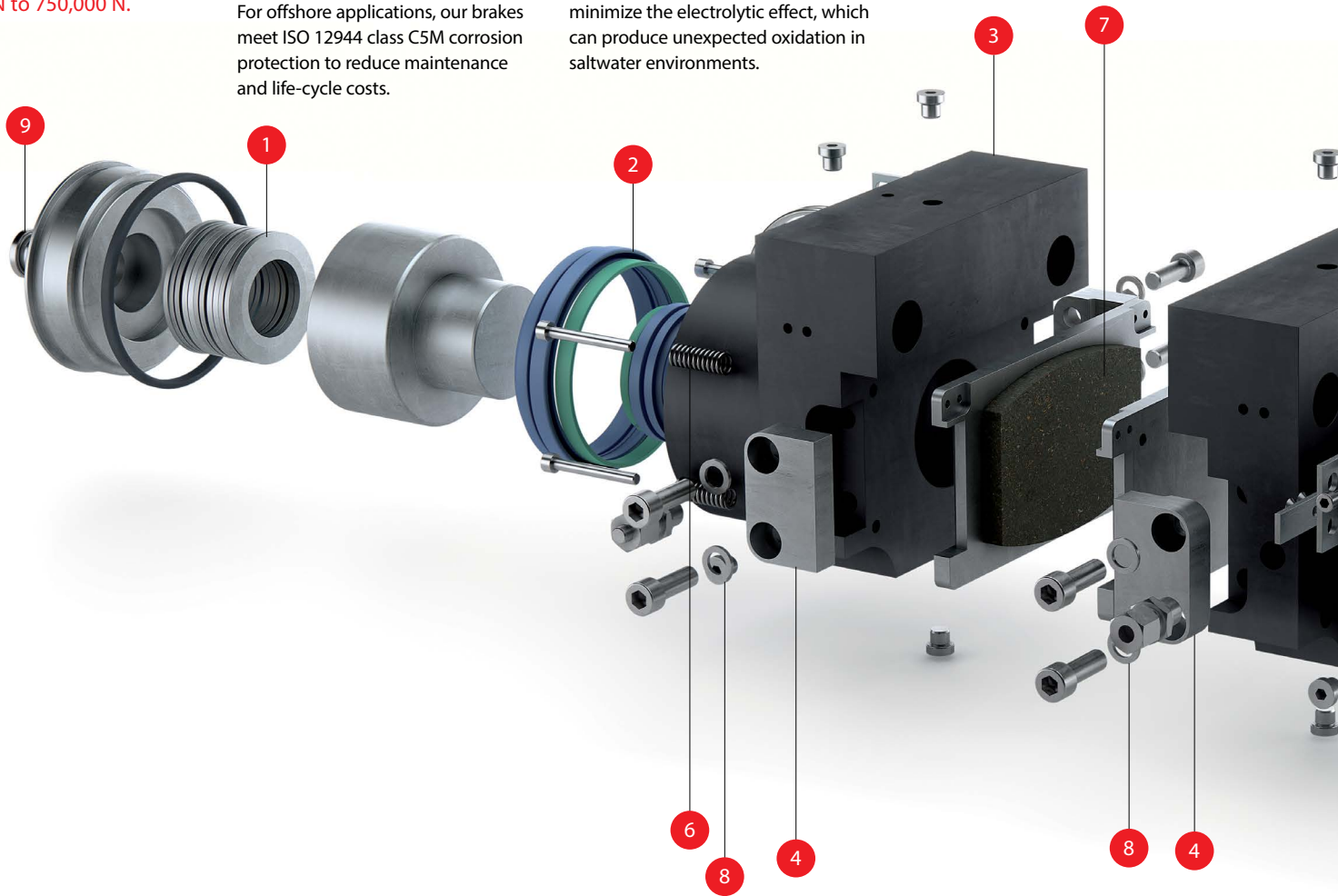

1 Spring pack
Cup spring pack designed for 2 million cycles.

2 Seals
Premium seals for high-pressure use and wide working temperature range.

3 Body
Steel body.

4 Lateral guides
Steel-made guides designed to support lateral forces and preserve the seals.

5 On/Off
Inox inductive switch.

6 Return spring system
To ensure pad/disc disengagement.

All materials, paint, and treatments of the brake parts and components have been chosen to resist corrosion in saltwater environments (full offshore protection) and minimize the electrolytic effect.

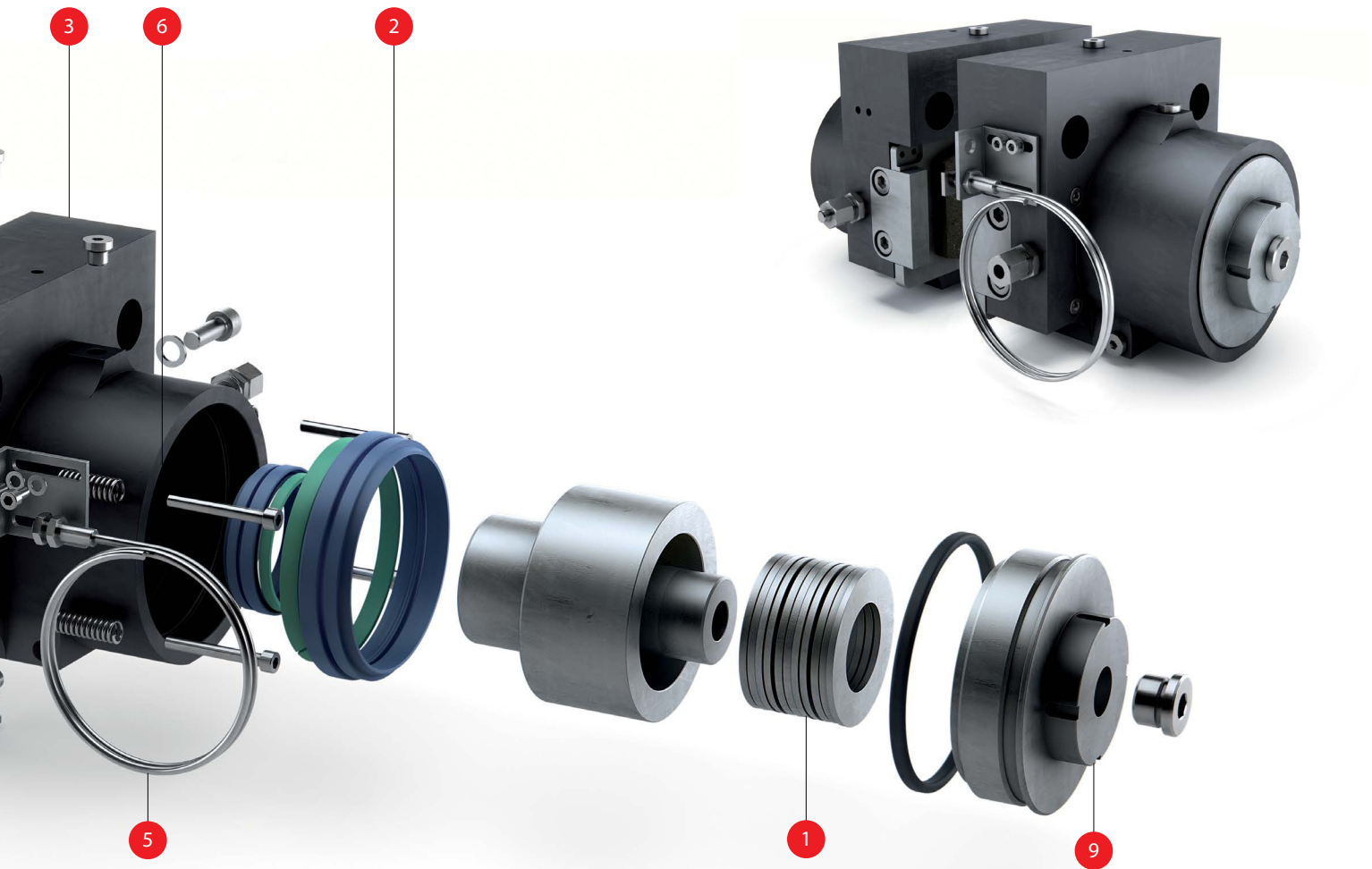

7 Pads
Self-aligning pads to reduce break-in time.

8 Washers
Anti-vibration approved washers.

9 Wear compensation system
New easy-to-handle design.

Hydraulic brakes

Hydraulic caliper brakes Oil applied



A3-ID



D3-ID



F3-ID



G3-ID

Hydraulic caliper brakes Spring applied



A3N-ID



D2N-ID



D3N-ID



EL4N-ID



F2N-ID



G3N-ID

Direct hydraulic brakes Oil applied



ID800



ID900



ID1500



ID2000



ID3000

Direct hydraulic brakes Spring applied



ID800N



ID900N



ID1500N



ID2000N



ID2500N



ID3000N



ID3005N

Other products

Brake discs



We offer a large range of standard or customized discs and mounting hubs. Flat steel discs, with or without hub, have been added to our cast iron disc offering. Made in normalized steel (C40+N) or stainless steel (AISI 316L), these discs have been tested and approved to perform with our friction material pads. They are available in 250 to 600 mm diameters and 12.7 to 25.5 mm thicknesses with surface hardness from 190 to 220 HB and roughness of 1.6 μm . Customized discs are also available.

Shaft couplings

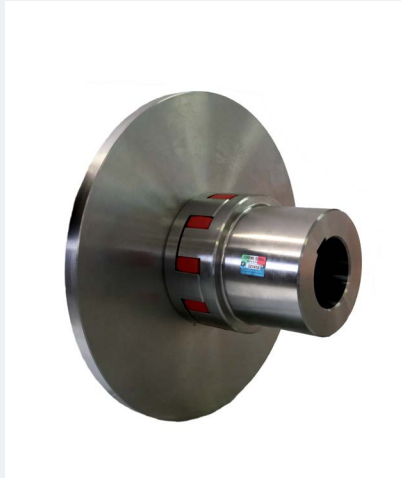

To offer a complete solution to our customers, Coremo can now supply a wide range of shaft couplings. Gear, flexible, steel lamina, and flanged couplings are available with or without discs.

Spare parts



Coremo maintains a safety stock and reacts quickly to spare parts requests. Brake linings, pistons, sensors, and seals are available promptly to help our customers avoid downtime.



Danfoss Power Solutions, Nordborgvej 81, 6430 Nordborg, Denmark, Tel. +45 74 88 22 22, Fax +45 74 65 25 80
www.danfoss.com, E-mail: info@danfoss.com

Any information, including, but not limited to information on selection of product, its application or use, product design, weight, dimensions, capacity or any other technical data in product manuals, catalogues descriptions, advertisements, etc. and whether made available in writing, orally, electronically, online or via download, shall be considered informative, and is only binding if and to the extent, explicit reference is made in a quotation or order confirmation. Danfoss cannot accept any responsibility for possible errors in catalogues, brochures, videos and other material. Danfoss reserves the right to alter its products without notice. This also applies to products ordered but not delivered provided that such alterations can be made without changes to form, fit or function of the product. All trademarks in this material are property of Danfoss A/S or Danfoss group companies. Danfoss and the Danfoss logo are trademarks of Danfoss A/S. All rights reserved.