

DOWMAX ME motor

Low-speed high-torque
Axial piston motor

Pressure: 280/250 bar rated, 325bar peak

Displacement: 99 to 4097cc

Torque: 15,990 Nm rated (motor itself)

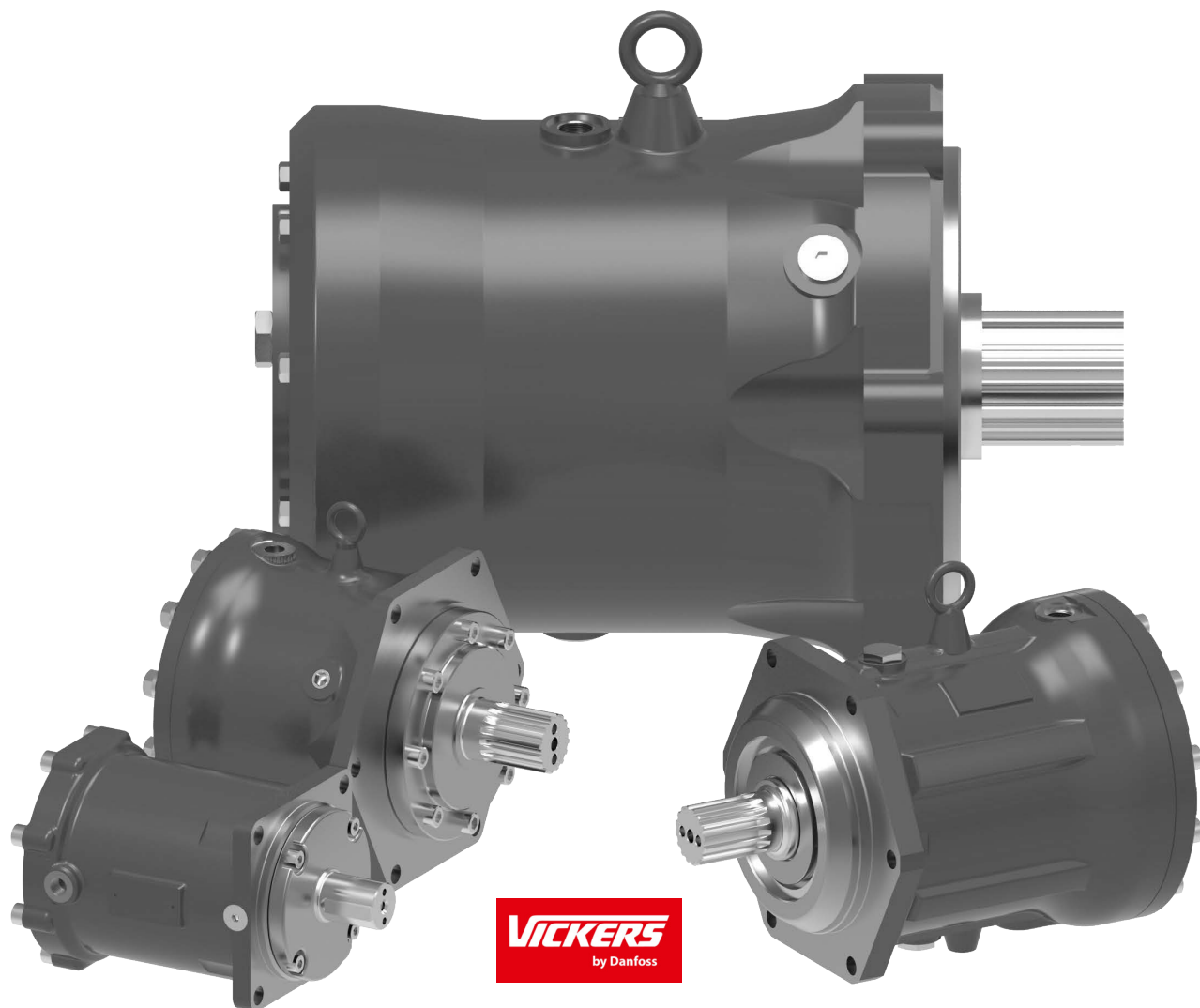

VICKERS
by Danfoss

Danfoss

ENGINEERING
TOMORROW

BC444081704987en-000102

Precautions for selecting DOWMAX motors



WARNING

- **Attention should be paid to the following matters when selecting DOWMAX motors.**

Carefully read precautions shown in the catalog and instruction manual to thoroughly understand them before selecting motors.

- **Check that the hydraulic system is planned in a manner to satisfy the matters described in the catalog, instruction manual, delivery drawing, manufacturing specifications, etc. Pay special attention to the following:**

1. The performance curves shown in this catalog show the summary (average values) of data on motors that have already been run-in. Provide sufficient margin of safety when selecting motors in accordance with specific applications. When motors are new (before running-in), they may fail to achieve the performance shown in the catalog. Contact us if that will cause any problem.
2. In cases where high back pressure is applied to the outlet line of the motor in a special application, the performance described in the catalog may not be exhibited. Contact us if the back pressure applied to the outlet line of the motor exceeds 2.0MPa (20kgf/cm²).
3. In cases where the motor is turned by a load, it is necessary to apply boost pressure to the suction line of the motor to prevent cavitation. The boost pressure is subject to the motor speed and the viscosity of hydraulic fluid. In general, apply pressure that exceeds the minimum boost pressure shown for each model.
4. In cases where external load torque is applied to the motor shaft while the motor is at rest, the motor will turn (slip) due to the leakage inside the motor. If there is no supply circuit, cavitation occurs and the motor goes out of control. (For example, a load will drop suddenly.) Use a mechanical brake as necessary in these cases.
5. In cases where the inertial force of a driving body is large, abnormal pressure will be produced. Measure the pressure of the actual motor, and use a brake valve if the peak pressure exceeds the value shown in the catalog; otherwise the motor shaft, key, and other parts may be damaged. Plan pipe installation in a manner to satisfy matters described in the related instruction manual.

- **Precautions for mechanical brake**

1. The mechanical brake of a DOW MAX motor is a reverse-operation type; the brake is released when brake pilot line is pressurized.
 - a. Pay attention, when planning the hydraulic circuit, to the brake pilot line not being pressurized at any time the brake is necessary, even if for a short time.
 - b. When residual pressure remains at the brake pilot line, brake torque decreases proportional to the residual pressure. Brake torque shown in this catalog is for the brake pilot line pressure of 0kgf/cm².
2. The mechanical brake of DOW MAX motor is originally for a static brake use (parking brake). Avoid the use of dynamic brake to the utmost. When dynamic brake is used unavoidably, pay attention to the following:
 - a. Mechanical brake and hydraulic brake shall not be used together. When the mechanical and hydraulic brake are planned to be used together, consult Danfoss for the applicability.
 - b. Usage classified as "Unsafe range" in the "Brake Use Limit Judging Diagram" in the related Instruction Manual shall be avoided.

- c. When the brake is used as a dynamic brake, the brake friction plate will be worn. Check the brake torque periodically and replace the brake friction plates with new ones, if necessary.
3. Brake torque shown in this catalog is for the use of standard mineral oil as a hydraulic fluid. When other oils such as fire-resistant fluid or special oils containing additive are used, brake characteristics will differ from the value in the catalog. Consult us in the case.
 - **Do not plan operation exceeding the usable conditions described in this catalog. (This does not apply to motors made to special specifications if special mention is shown in the delivery drawing or product specifications.)**

1. Operation exceeding the viscosity range of 15-500 cSt.
2. Operation exceeding the usable range (pressure and speed). Refer to this catalog for confirmation of limits for respective models.
3. Operation exceeding the allowable external force (radial and thrust load). Refer to the shaft strength diagrams shown in this catalog for confirmation.
4. Operation exceeding the operating conditions (pressure and speed) corresponding to the desired life of motor. Check the bearing life diagrams shown in this catalog for confirmation.
5. Operation in cold places (below -25°C). (Contact us for special motors for operation at temperatures from -25°C to -45°C.)
6. Operation that causes the case temperature to exceed 80°C.

* Never remodel motors.



CAUTION

- Use the recommended hydraulic fluid shown in the instruction manual. When fire-resistant fluid is used, strictly observe the cautions and notes described in the instruction manual. Standard motors cannot be used when phosphate-ester is used as hydraulic fluid. In that case, select the seal code of V or X (seal material: fluororubber). As in the case of water-glycol type hydraulic fluid, the motor life can substantially be shortened depending on the type of fire-resistant fluid. (Contact us for the expected life of motor under specific operating condition.)
- When the direction of rotation of the motor is to be changed frequently, select models with a spline shaft.
- Metal chips, sand, and other fine foreign substances contained in hydraulic fluid will reach the sliding surface of the motor, advancing the abrasion of component parts and causing malfunction and seizure of the motor. Prevent entry of dust, and be sure to install a filter in the circuit. Refer to the related instruction manual for the filter specifications.
- Precautions regarding the drain port position and drain piping are described in the related instruction manual. Be sure to refer to them and reflect them in the piping plan.
- When installation of motor with its shaft facing upward is desired, select "DOWMAX for installing the shaft upward" (mentioned before) that permits air bleeding from the case.
- Keep the drain pressure inside the motor case below 0.3MPa (3 kgf/cm²). Take care the pressure as it rises depending on the tank position and the length and diameter of pipes. The pressure on the low-pressure side of the main port must be higher than the drain pressure.
- When the shaft is exposed to water or seawater, the standard seal will allow the shaft to rust, and the abraded oil seal may cause oil leakage. In such a case, select or specify models made to the double oil seal specifications.

Table of contents

ME motor	8
MK two-speed motor	51
MB motor with mechanical brake	59
ME motor with hollow shaft	
ME motor with planetary gear	
Single reduction	77
Double reduction	79
Shield tunneling application	81
Counter balance valve with brake valves	84

Array of DOWMAX base products

Optional features	Two-speed motor	Mechanical brake	Single stage planetary gearbox	Double stage planetary gearbox	Counter balance valve	Speed detection shaft	Speed sensor	Hollow shaft
ME100		X	X	X	X	X	X	
ME150		X	X	X	X	X	X	
ME175		X	X	X	X	X	X	
ME300B	X	X	X	X	X	X	X	
ME350B		X	X	X	X	X	X	
ME600B	X	X	X	X	X	X	X	
ME750B		X	X	X	X	X	X	
ME850B		X	X	X	X	X	X	
ME1300A			X	X	X	X	X	
ME1900			X		X	X	X	
ME2600			X		X	X	X	X
ME3100					X	X	X	
ME4100					X	X	X	X

Note: Above are standard available options, please contact Danfoss representative for any other combinations - which is not available above.

DOWMAX ME motor

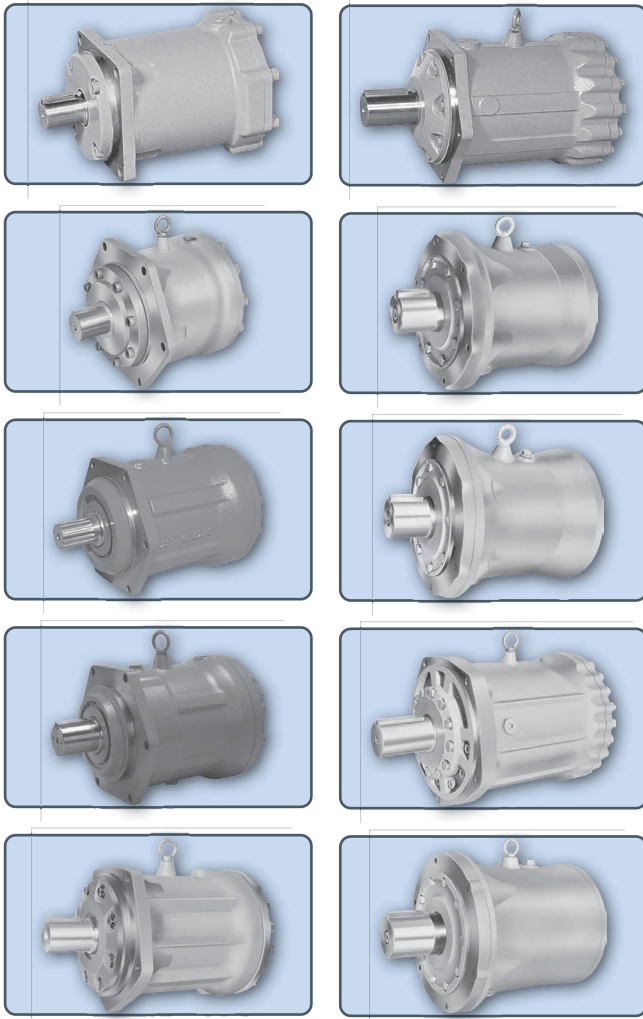

ME low-speed high-torque motor is a double swash plate type axial piston motor and has highest performance at low-speed range.

- Wide range of models - 13 displacements from 99 to 4097cm³/rev are available.
- High pressure-Continuous operating pressure 27.5Mpa (280kgf/cm²) & 24.5Mpa (250kgf/cm²).
- Smooth operation at low-speed. Multiple pistons and double swash plate result in smooth rotation at speeds down to 1 rev/min.
- High starting torque and high overall efficiency.
- Compact and easy installation.
- Robust construction.
- Quiet operation.
- Unaffected by thermal shock (good for starting at cold temperature).
- Speed pickup system is available.

Table of contents

Structure, operation, performance data	6
Coding, selection chart	7
ME100.....	8
ME150.....	10
ME175.....	12
ME300B	14
ME350B	16
ME600B	18
ME750B	20
ME850B	22
ME1300A	24
ME1900	26
ME2600	28
ME3100	30
ME4100	32
Inch size shaft and SAE ports	34
Bearing life and allowable radial load for shaft.....	43
Accessory parts	48
Standardized for special functions	50

DOW MAX, is respectively registered trade mark.

DOWMAX ME motor

Structure and operation

Fluid entering the supply port is directed via internal passages and timing plate to the center of the cylinder bores. Fluid pressure forces the pistons apart causing the slippers to slide on the angled faces of the swash plates and rotate the barrel and shaft assembly. After work, fluid is exhausted through the timing plate and internal passages to the return port.

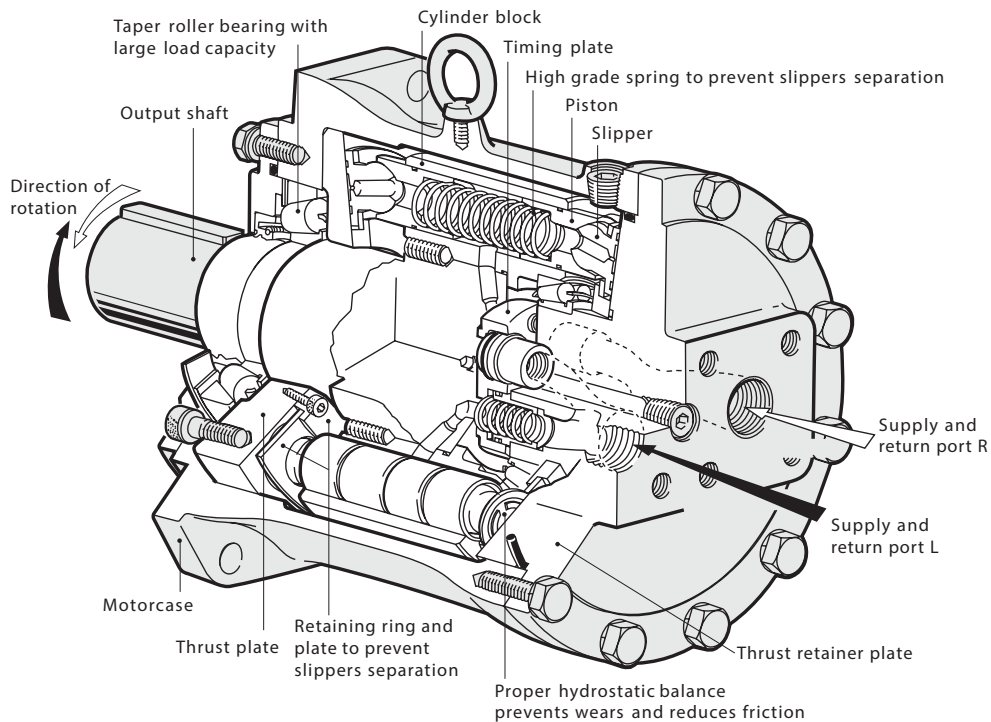

Performance data

Model	Displacement cm ³ /rev	Rated pressure MPa (kgf/cm ²)	Peak pressure MPa (kgf/cm ²)	Rated torque Nm (kgfm)	Rated speed rpm	Max. speed rpm	Rated horse power kW(P S)	Mass Kg		
ME100	99	27.5 (280)	31.9 (325)	432 (44)	1000	1000	45 (62)	22		
ME150	152			667 (68)	600	800	42 (57)	42		
ME175	175			765 (78)	600	800	48 (65)	42		
ME300B	300			1320 (135)	660	800	90 (123)	60		
ME350B	350			1530 (156)	660	800	106 (144)	60		
ME600B	600			2620 (267)	500	600	137 (186)	96		
ME750B	750			3280 (334)	450	520	154 (210)	123		
ME850B	848			3708 (378)	400	450	155 (211)	123		
ME1300A	1345			24.5 (250)		5250 (535)	200	390	138 (188)	170
ME1900	1868					7290 (743)	140	260	128 (174)	270
ME2600	2578	10070 (1026)	110			230	159 (216)	350		
ME3100	3104	12120 (1235)	110			230	186 (253)	364		
ME4100	4097	15990 (1630)	75			200	211 (287)	520		

□ Limit of hydraulic fluid temperature; -20°C~80°C

□ Limit of hydraulic fluid viscosity; 15~500cSt (Advisable fluid viscosity range; 25~100cSt)

DOWMAX ME motor

Coding

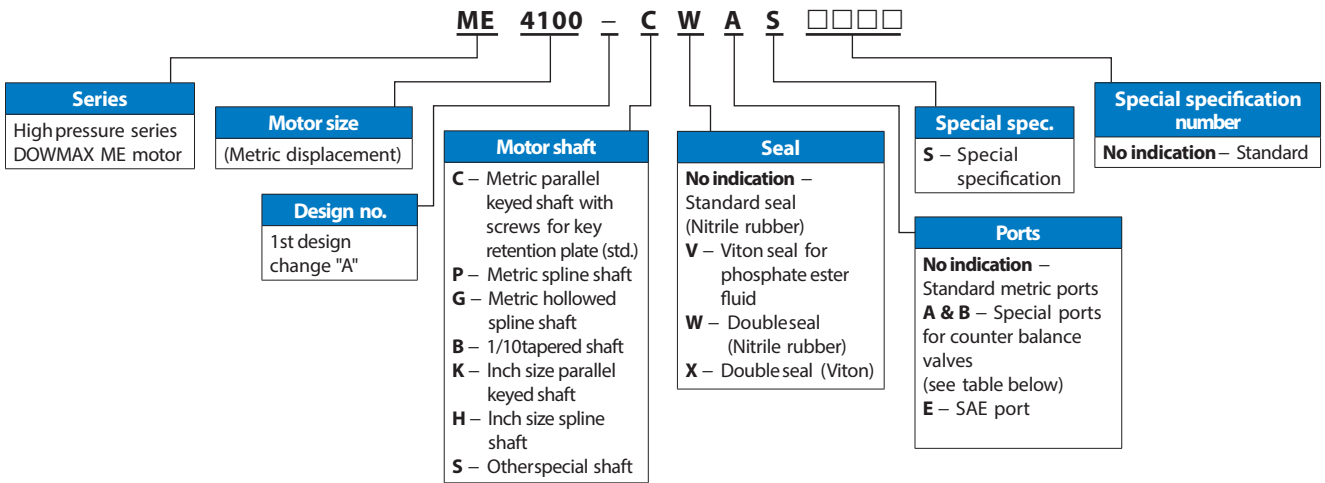

Port symbol for attaching counter balance valve

– Means Std. port

Model Valve	ME100	ME150 ~ ME850B	ME1300A	ME1900	ME2600	ME3100	ME4100
C100□	–	A	A	A	A	–	–
C300□B	*	B	A	B	B	–	B
CW300A	*	B	A	B	B	–	B

* Valves cannot be attached

Selection chart

This chart indicates the relation of actual torque and shaft rotation at the rated pressure of 27.5MPa (280kgf/cm²) and 24.5MPa (250kgf/cm²).

Given the required torque and shaft speed the appropriate model can be selected from the diagram. When the operating pressure differs from 27.5 or 24.5MPa (280 or 250kgf/cm²), refer to the performance data for the respective model.

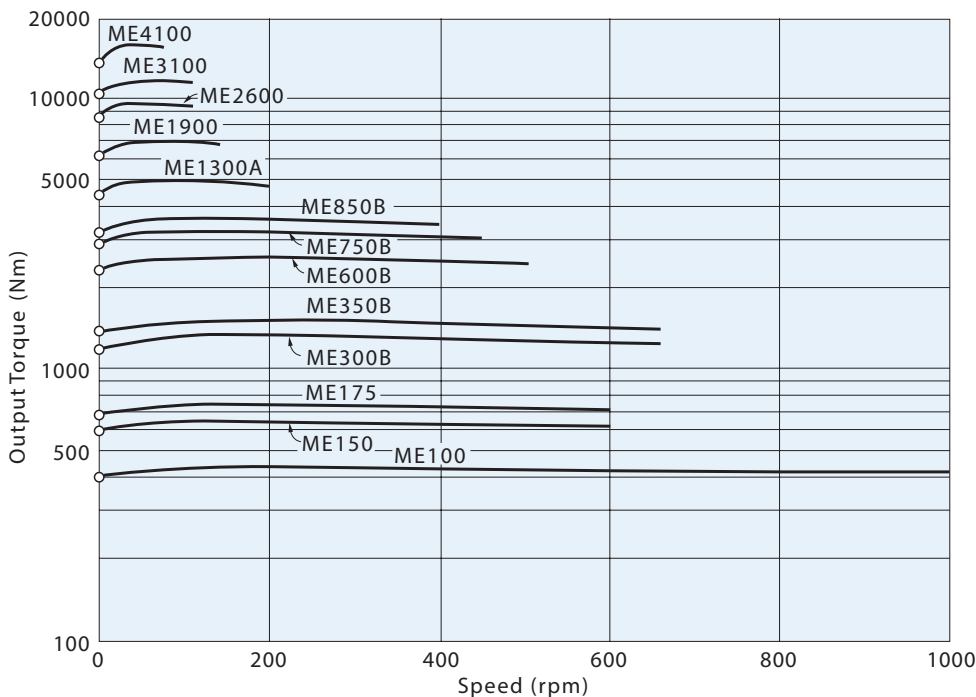

DOWMAX ME motor

ME100

(Dimensions in mm)

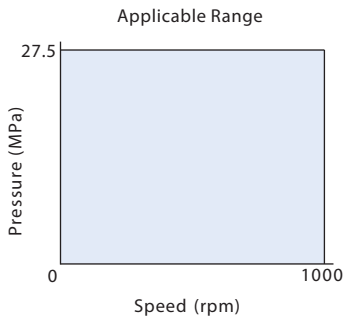

Displacement	99cm ³ /rev
Rated pressure	27.5MPa (280kgf/cm ²)
Peak pressure	31.9MPa (325kgf/cm ²)
Rated torque	432Nm (44kgfm)
Rated speed	1000rpm
Max. speed	1000rpm
Rated horsepower	45kW (62PS)
Mass	22kg

Nominal dimensions

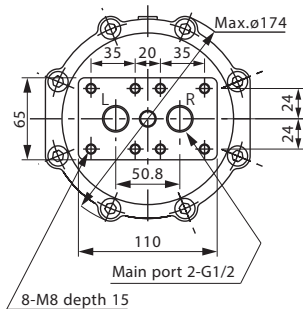
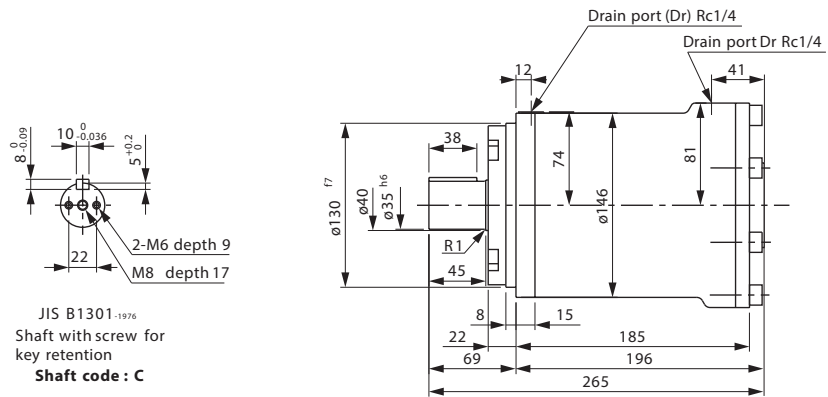
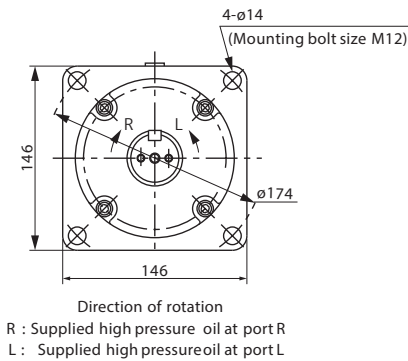

Splined shaft

Shaft code : P

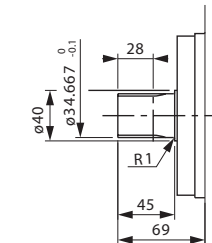
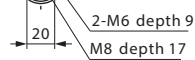

Tapered shaft (1/10 taper)

Shaft code : B (Single oil seal)

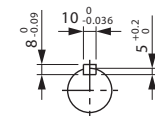

Seal land area of shaft is chrome plated

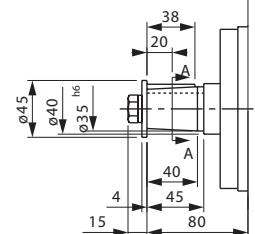

Tapered shaft (1/10 taper)

Shaft code : BW (Double oil seal)

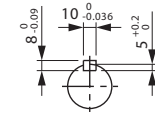
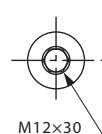

Seal land area of shaft is chrome plated

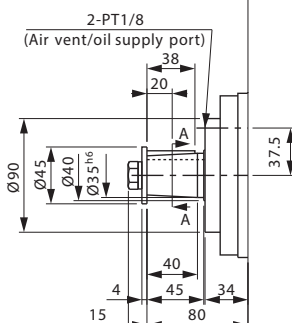

JIS D2001 Involute spline

35 x 19 x 1.667 (Class b)

Shaft	Coefficient of profile shifting	
Tool	Tooth form	Stub tooth
	Module	1.667
	Pressure angle	20°
Shaft	Number of teeth	19
	Dia. of basic pitch circle	31.667
Shaft thickness	Grade	Class b (flank fit)
	Over-pin dia.	37.819 ^{+0.019} _{-0.110} Pin dia.=ø3.0
Tooth thickness	Over-all, across a given number of teeth (reference)	13.656 ^{+0.003} _{-0.058} (3-teeth)
	Outer dia.	34.667
Shaft	Inner dia.	31.000
	Coefficient of profile shifting	
		+ 0.800
Tool	Tooth form	Stub tooth
	Module	1.667
	Pressure angle	20°
Shaft	Number of teeth	19
	Dia. of basic pitch circle	31.667
Hole	Over-pin dia.	28.337 ^{+0.085} Pin dia.=ø3.333 Thickness of chamfered part=2.80
	Over-all, Displacement across a given number of grooves (reference)	13.656 ^{+0.036} _{-0.008} (3-teeth)
Hole	Outer dia.	35.50
	Inner dia.	31.7 ^{+0.025} ₀

DOWMAX ME motor

Performance data

Fluid: Shell tellus 56 (Viscosity 37cSt at 50°C)

The graphs shown are mean values obtained for production units.

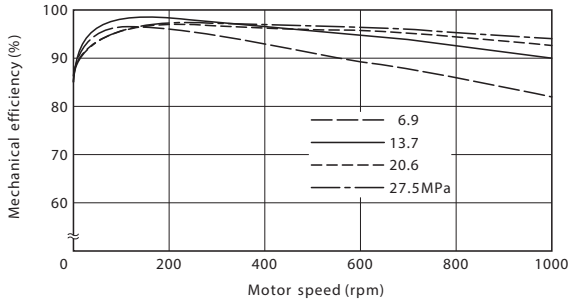

Fig. 1: Mechanical efficiency

Mechanical efficiency at various speeds is shown for 4 operating pressures.

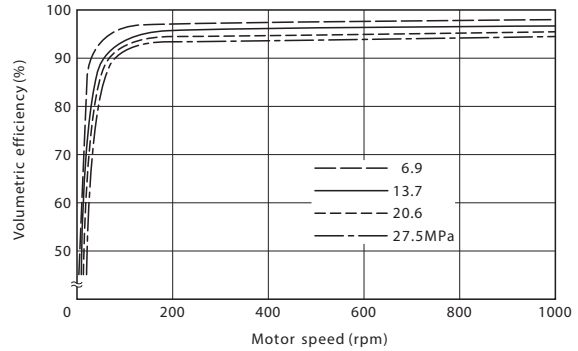

Fig. 2: Volumetric efficiency

Volumetric efficiency at various speeds is shown for 4 operating pressures.

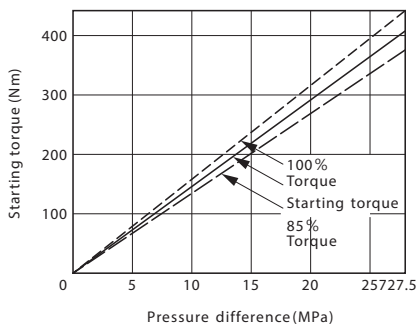

Fig. 3: Starting torque

Starting torque versus effective pressure is shown. Oil viscosity will not affect the starting torque efficiency.

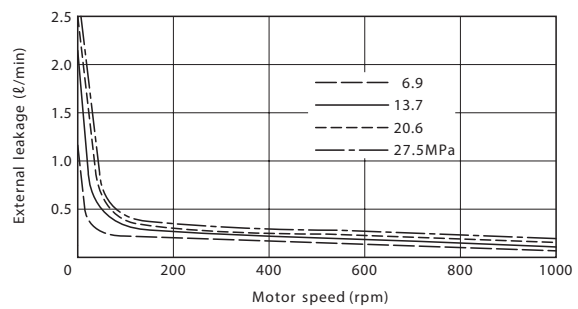

Fig. 4: External leakage

External leakage (from motor drain ports) relative to various speeds is shown for 4 operating pressures.

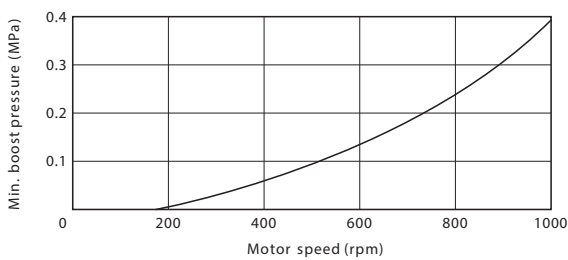

Fig. 5: Minimum boost pressure

It is important that sufficient inlet pressure is maintained, when the motor is operated as a pump or when the load overruns the motor, to prevent cavitation.

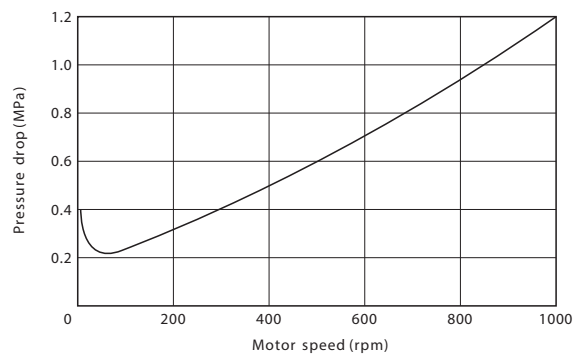

Fig. 6: Pressure drop

Pressure necessary to run motor without load is shown for various speeds.

DOWMAX ME motor

ME150

(Dimensions in mm)

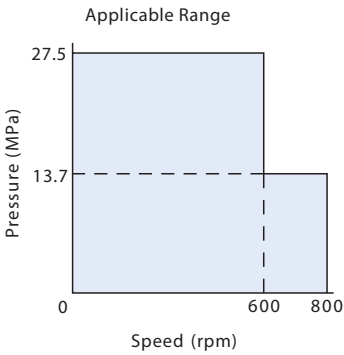

Displacement	152cm ³ /rev
Rated pressure	27.5MPa (280kgf/cm ²)
Peak pressure	31.9MPa (325kgf/cm ²)
Rated torque	667Nm (68kgfm)
Rated speed	600rpm
Max. speed	800rpm
Rated horse power	42kW (57PS)
Mass	42kg

Nominal dimensions

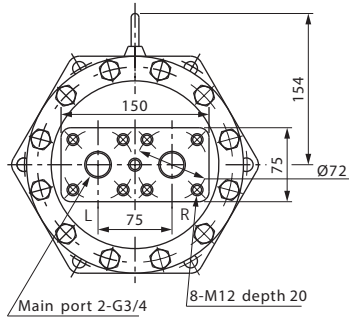
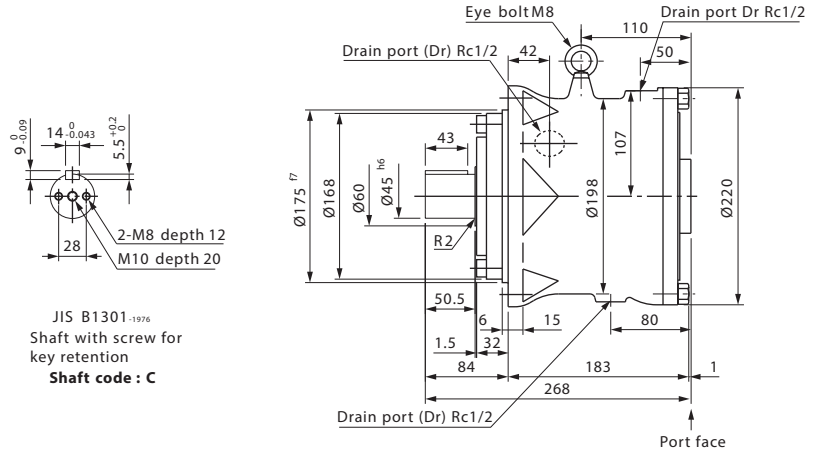
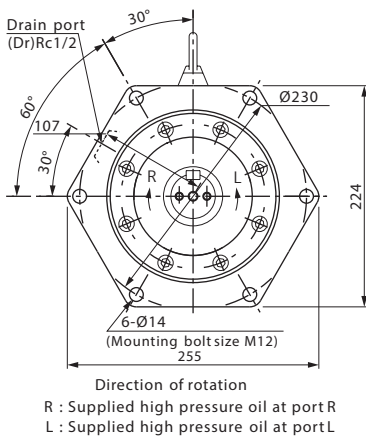

Tapered shaft (1/10 taper)
Shaft code : B (Single oil seal)



Tapered shaft (1/10 taper)
Shaft code : BW (Double oil seal)



Splined shaft

Shaft code : P

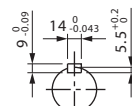
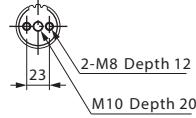

A ~ A
Seal land area of shaft is chrome plated

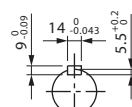

A ~ A
Seal land area of shaft is chrome plated

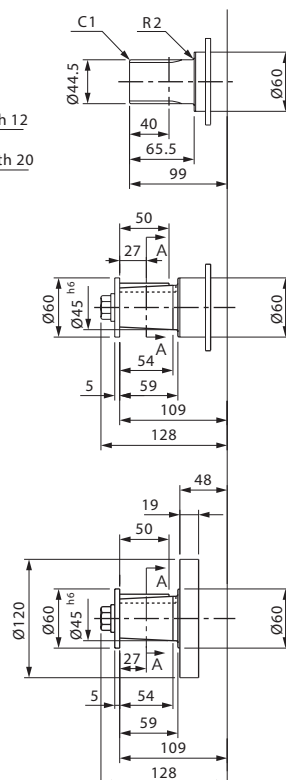

JIS D2001 Involute spline
45 × 16 × 2.5 (Class b)

Tool	Coefficient of profile shifting	+ 0.800
	Tooth form	Stub tooth
	Module	2.5
	Pressure angle	20°
Shaft	Number of teeth	16
	Dia of basic pitch circle	40
	Grade	Class b (Flank fit)
	Over-pin dia	49.277 ^{+0.018} _{-0.107} Pin dia=Ø4.5
Tooth thickness	Overall, across a given number of teeth (reference)	20.379 ^{-0.001} _{-0.058} (3-teeth)
	Outer dia	44.5
	Inner dia	39
	Hole	Coefficient of profile shifting
Tool		Tooth form: Stub tooth Module: 2.5 Pressure angle: 20° Number of teeth: 16
Dia of basic pitch circle		40
Tooth width		35.168 ^{+0.085} ₀ Pin dia=Ø5 Thickness of chamfered Part=4.26
Tooth width	Overall, displacement across a given number of grooves (reference)	20.379 ^{-0.030} _{-0.009} (3-teeth)
	Outer dia	45.75
	Inner dia	40 ^{+0.025}

DOWMAX ME motor

Performance data

Fluid: Shell tellus 56 (Viscosity 37cSt at 50°C)

The graphs shown are mean values obtained for production units.

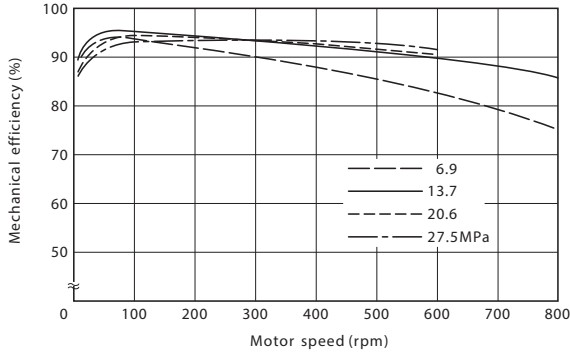

Fig. 1: Mechanical efficiency

Mechanical efficiency at various speeds is shown for 4 operating pressures.

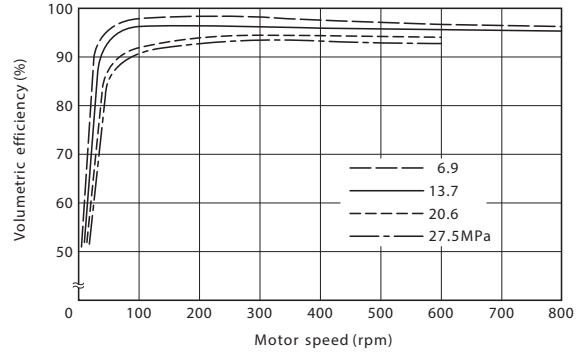

Fig. 2: Volumetric efficiency

Volumetric efficiency at various speeds is shown for 4 operating pressures.

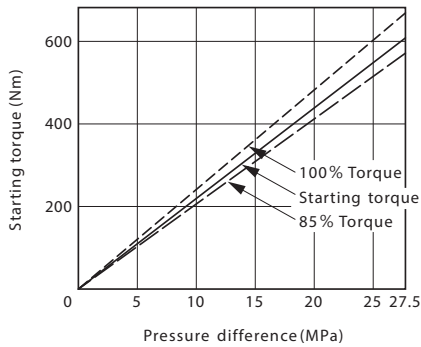

Fig. 3: Starting torque

Starting torque versus effective pressure is shown. Oil viscosity will not affect the starting torque efficiency.

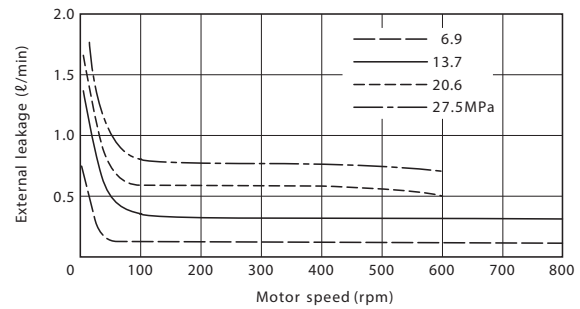

Fig. 4: External leakage

External leakage (from motor drain ports) relative to various speeds is shown for 4 operating pressures.

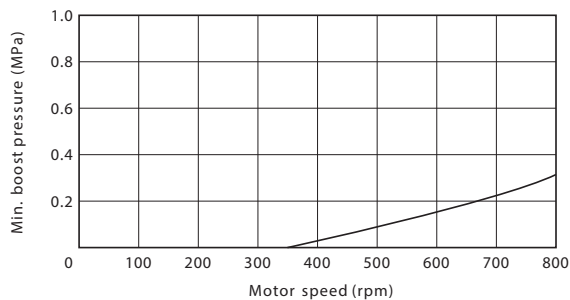

Fig. 5: Minimum boost pressure

It is important that sufficient inlet pressure is maintained, when the motor is operated as a pump or when the load overruns the motor, to prevent cavitation.

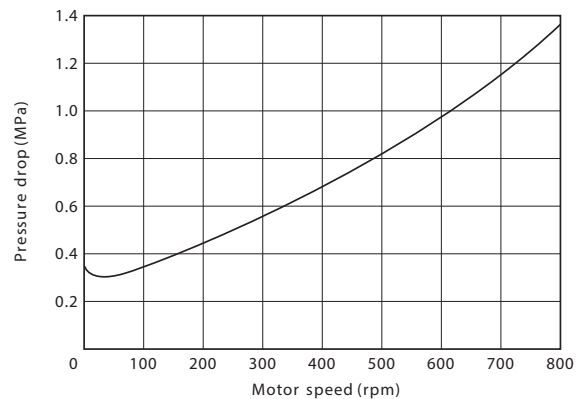

Fig. 6: Pressure drop

Pressure necessary to run motor without load is shown for various speeds.

DOWMAX ME motor

ME175

(Dimensions in mm)

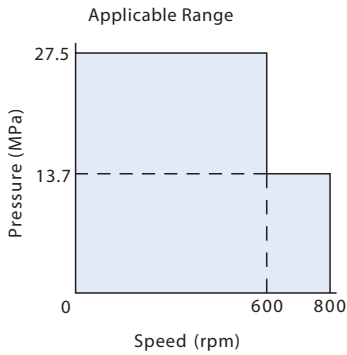

Displacement	175cm ³ /rev
Rated pressure	27.5MPa (280kgf/cm ²)
Peak pressure	31.9MPa (325kgf/cm ²)
Rated torque	765Nm (78kgfm)
Rated speed	600rpm
Max. speed	800rpm
Rated horse power	48kW (65PS)
Mass	42kg

Nominal dimensions

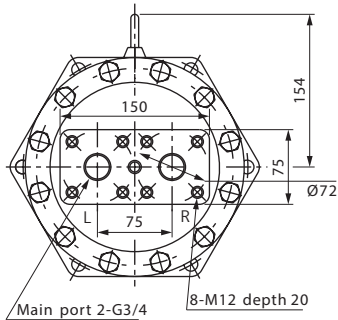
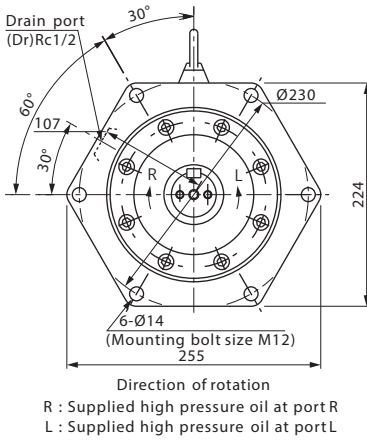

Tapered shaft (1/10 taper)
Shaft code : B (Single oil seal)



Tapered shaft (1/10 taper)
Shaft code : BW (Double oil seal)

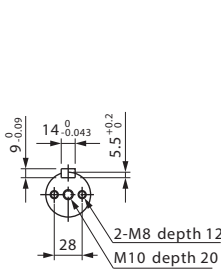

JIS B1301-1976
Shaft with screw for key retention
Shaft code : C

Splined shaft
Shaft code : P

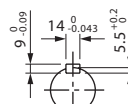
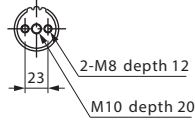

A ~ A
Seal land area of shaft is chrome plated

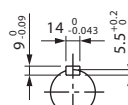

A ~ A
Seal land area of shaft is chrome plated

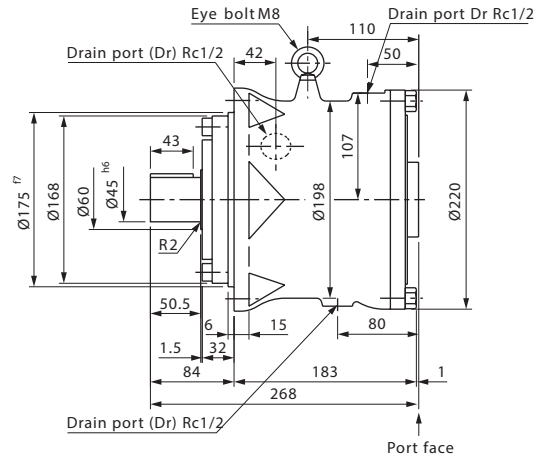

JIS D2001 Involute spline
45 × 16 × 2.5 (Class b)

Shaft	Coefficient of profile shifting	+ 0.800
	Tool	Tooth form Stub tooth
		Module 2.5
		Pressure angle 20°
		Number of teeth 16
Shaft	Dia. of basic pitch circle	40
	Grade	Class b (flank fit)
	Over-pin dia.	49.277 ^{+0.018} - 0.107
	Overall, across a given number of teeth (reference)	20.379 ^{-0.001} - 0.038
		(3-teeth)
Hole	Outer dia.	44.5
	Inner dia.	39
	Coefficient of profile shifting	+ 0.800
	Tool	Tooth form Stub tooth
		Module 2.5
Hole	Pressure angle	20°
	Number of teeth	16
	Dia. of basic pitch circle	40
	Over-pin dia.	35.168 ^{+0.085} - 0.05
	Overall, displacement across a given number of grooves (reference)	20.379 ^{+0.030} - 0.009
	(3-teeth)	
Hole	Outer dia.	45.75
	Inner dia.	40 ^{+0.025}

DOWMAX ME motor

Performance data

Fluid: Shell tellus 56 (Viscosity 37cSt at 50°C)

The graphs shown are mean values obtained for production units.

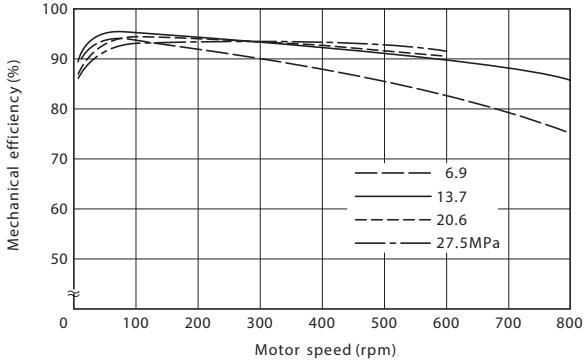

Fig. 1: Mechanical efficiency

Mechanical efficiency at various speeds is shown for 4 operating pressures.

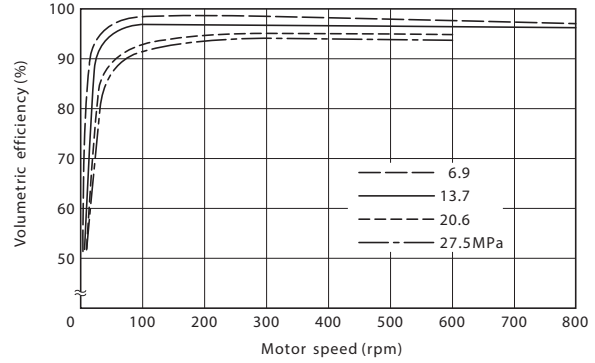

Fig. 2: Volumetric efficiency

Volumetric efficiency at various speeds is shown for 4 operating pressures.

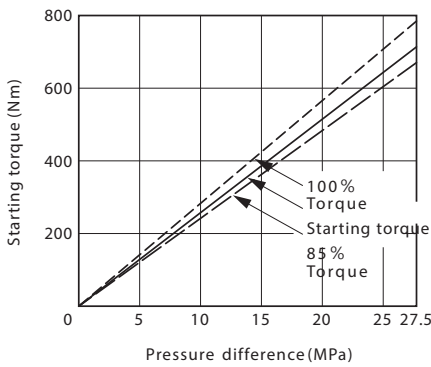

Fig. 3: Starting torque

Starting torque versus effective pressure is shown. Oil viscosity will not affect the starting torque efficiency.

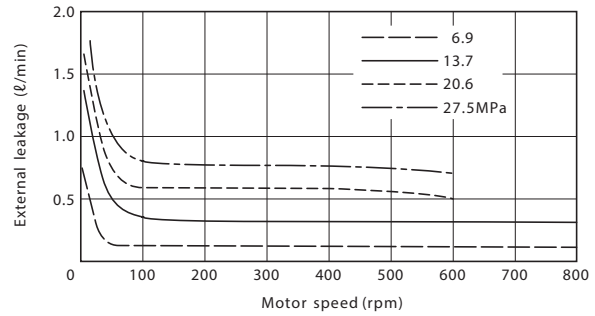

Fig. 4: External leakage

External leakage (from motor drain ports) relative to various speeds is shown for 4 operating pressures.

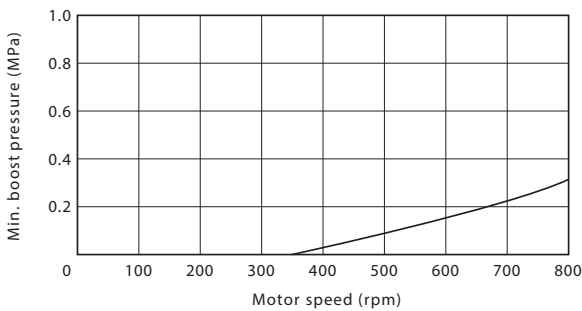

Fig. 5: Minimum boost pressure

It is important that sufficient inlet pressure is maintained, when the motor is operated as a pump or when the load overruns the motor, to prevent cavitation.

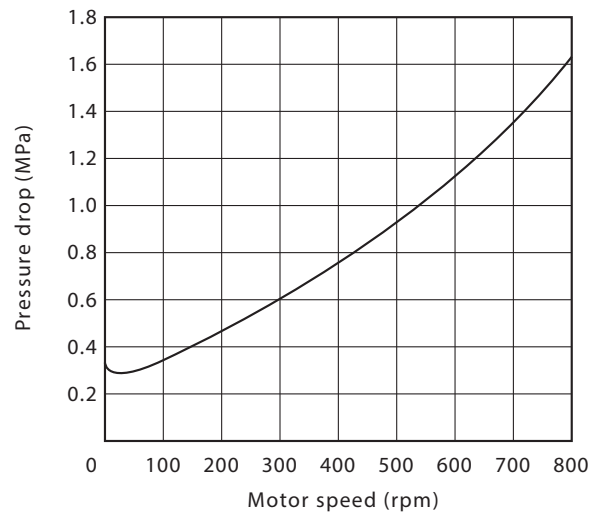

Fig. 6: Pressure drop

Pressure necessary to run motor without load is shown for various speeds.

DOWMAX ME motor

ME300B

(Dimensions in mm)

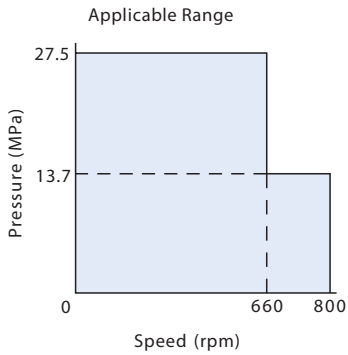

Displacement	300cm ³ /rev
Rated pressure	27.5MPa (280kgf/cm ²)
Peak pressure	31.9MPa (325kgf/cm ²)
Rated torque	1320Nm (134kgfm)
Rated speed	660rpm
Max. speed	800rpm
Rated horse power	90kW (123PS)
Mass	60kg

Nominal dimensions

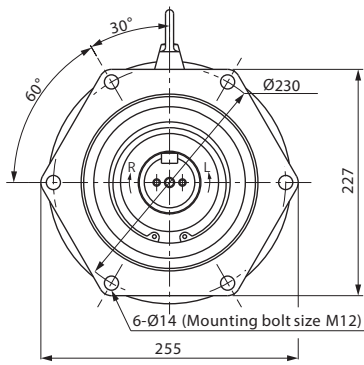

Direction of rotation
R : Supplied high pressure oil at port R
L : Supplied high pressure oil at port L

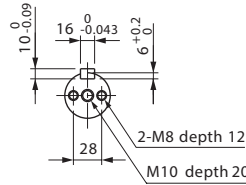

JIS B1301-1976
Shaft with screw for key retention
Shaft code : C

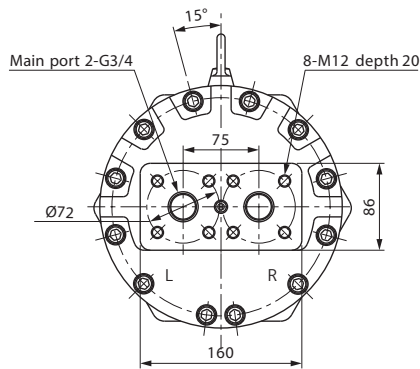
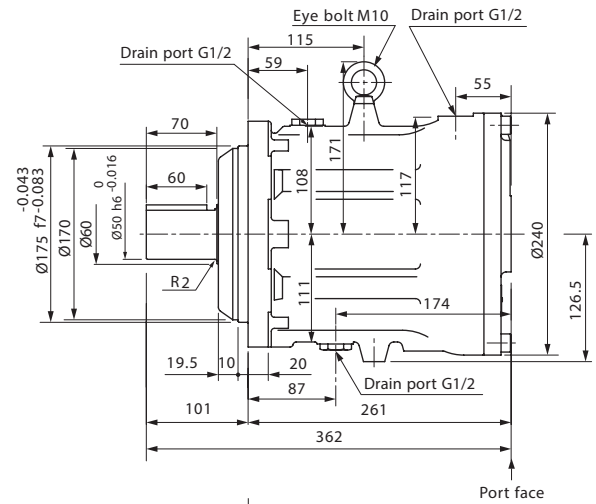

Splined shaft
Shaft code : P

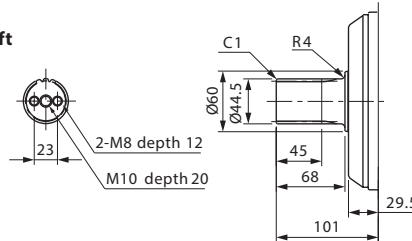

Tapered shaft (1/10 taper)
Shaft code : B (Single oil seal)

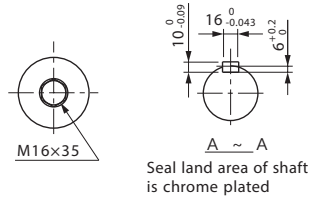

Tapered shaft (1/10 taper)
Shaft code : BW (Double oil seal)

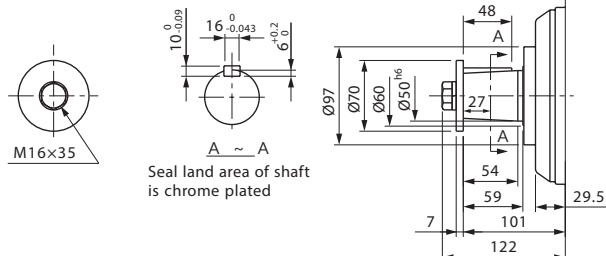

JIS D2001 Involute spline
45 × 16 × 2.5 (Class b)

Shaft	Coefficient of profile shifting	
	Tooth form	Stub tooth
	Module	2.5
	Pressure angle	20°
Shaft thickness	Number of teeth	16
	Dia. of basic pitch circle	40
	Grade	Class b (flank fit)
	Over-pin dia.	49.277 ^{+0.018} _{-0.107}
Tooth thickness	Overall, across a given number of teeth (reference)	20.379 ^{+0.001} _{-0.058}
		(3-teeth)
	Outer dia.	44.5
Hole	Coefficient of profile shifting	
	Tooth form	Stub tooth
	Module	2.5
	Pressure angle	20°
Hole width	Number of teeth	16
	Dia. of basic pitch circle	40
	Over-pin dia.	35.168 ^{+0.085} ₀
	Overall, displacement across a given number of grooves (reference)	20.379 ^{+0.030} _{-0.009}
	(3-teeth)	
Outer dia.	45.75	
Inner dia.	40 ^{+0.025} ₀	

Details of drain port

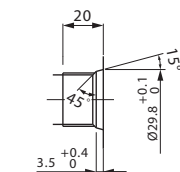

Details of main port

DOWMAX ME motor

Performance data

Fluid: Shell TellusK46 (Viscosity 30cSt at 50°C)

The graphs shown are mean values obtained for production units.

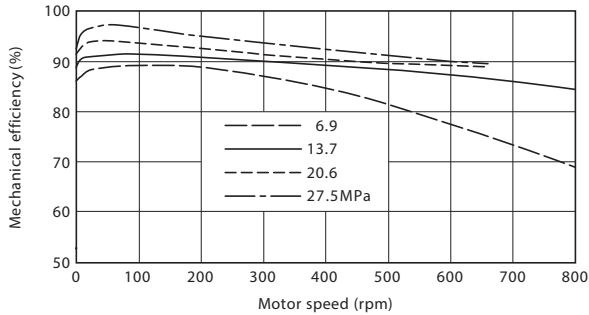

Fig. 1: Mechanical efficiency

Mechanical efficiency at various speeds is shown for 4 operating pressures.

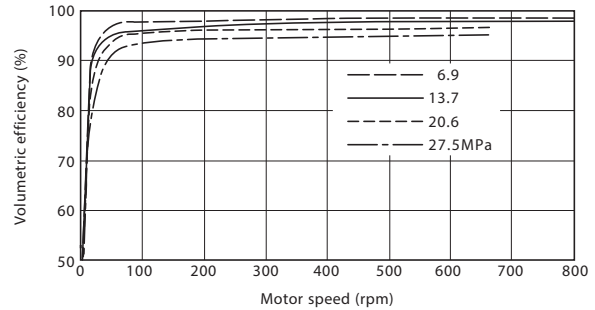

Fig. 2: Volumetric efficiency

Volumetric efficiency at various speeds is shown for 4 operating pressures.

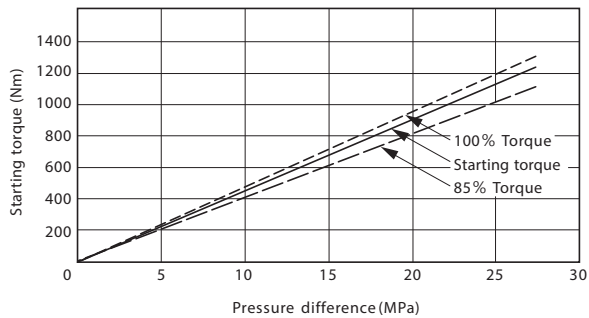

Fig. 3: Starting torque

Starting torque versus effective pressure is shown. Oil viscosity will not affect the starting torque efficiency.

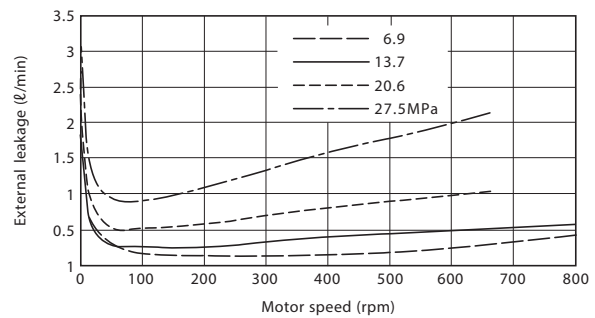

Fig. 4: External leakage

External leakage (from motor drain ports) relative to various speeds is shown for 4 operating pressures.

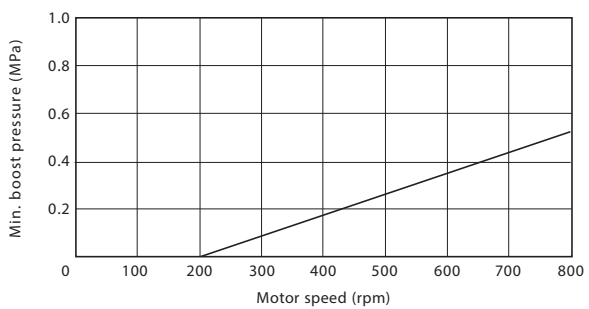

Fig. 5: Minimum boost pressure

It is important that sufficient inlet pressure is maintained, when the motor is operated as a pump or when the load overruns the motor, to prevent cavitation.

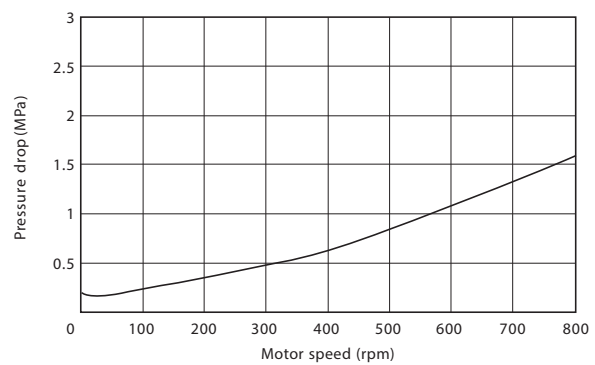

Fig. 6: Pressure drop

Pressure necessary to run motor without load is shown for various speeds.

DOWMAX ME motor

ME350B

(Dimensions in mm)

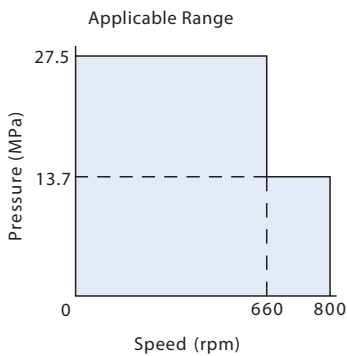

Displacement	350cm ³ /rev
Rated pressure	27.5MPa (280kgf/cm ²)
Peak pressure	31.9MPa (325kgf/cm ²)
Rated torque	1530Nm (156kgfm)
Rated speed	660rpm
Max. speed	800rpm
Rated horse power	106kW (144PS)
Mass	60kg

Nominal dimensions

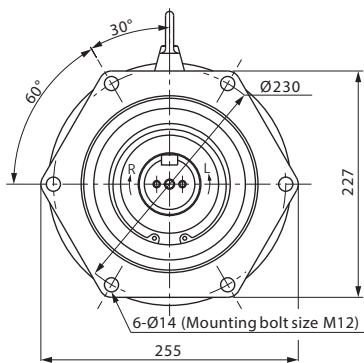

Direction of rotation
 R : Supplied high pressure oil at port R
 L : Supplied high pressure oil at port L

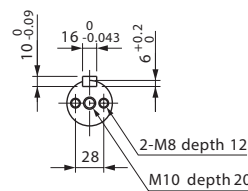

JIS B1301-1976
 Shaft with screw for key retention
Shaft code : C

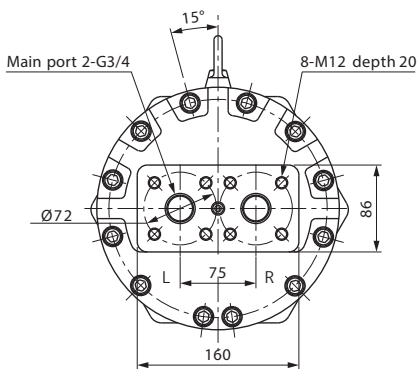
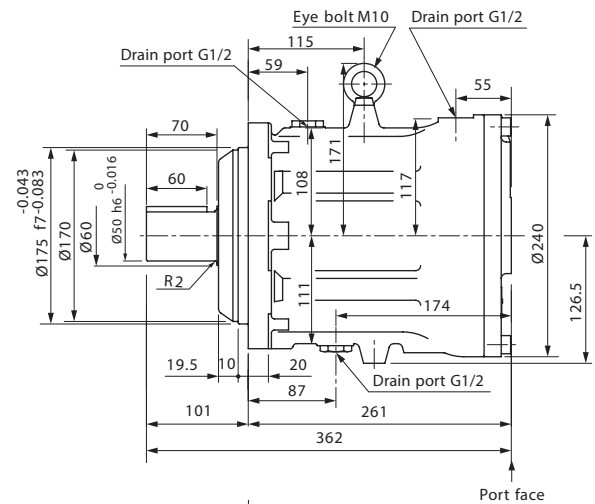

Splined shaft
Shaft code : P

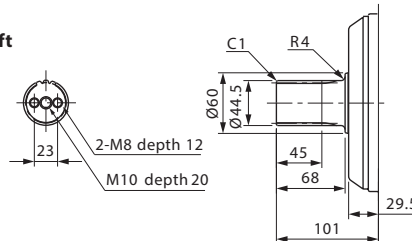

Tapered shaft (1/10 taper)
Shaft code : B (Single oil seal)

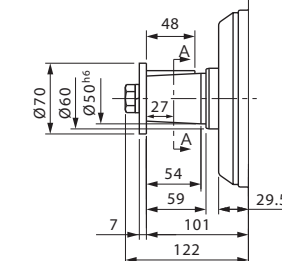
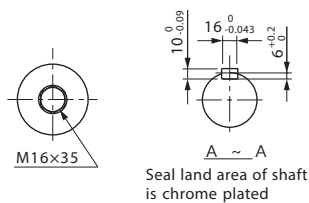

Tapered shaft (1/10 taper)
Shaft code : BW (Double oil seal)

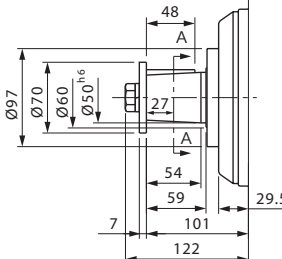
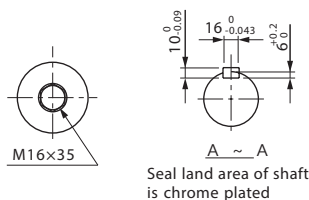

JIS D2001 Involute spline
45 × 16 × 2.5 (Class b)

Shaft	Coefficient of profile shifting	+ 0.800	
	Tool	Tooth form	Stub tooth
		Module	2.5
	Pressure angle	20°	
	Number of teeth	16	
	Dia. of basic pitch circle		40
Grade		Class b (flank fit)	
Tooth thickness	Over-pin dia.	49.277 ^{-0.018} _{-0.107}	
	Overall, across a given number of teeth (reference) (3-teeth)	20.379 ^{-0.001} _{-0.058}	
Outer dia.	44.5		
Inner dia.	39		
Hole	Coefficient of profile shifting	+ 0.800	
	Tool	Tooth form	Stub tooth
		Module	2.5
	Pressure angle	20°	
	Number of teeth	16	
	Dia. of basic pitch circle	40	
Tooth width	Over-pin dia.	35.168 ^{+0.085} ₀	
	Overall, displacement across a given number of grooves (reference) (3-teeth)	20.379 ^{+0.030} _{-0.009}	
Outer dia.	45.75		
Inner dia.	40 ^{+0.025} ₀		

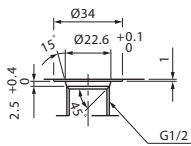

Details of drain port

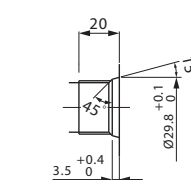

Details of main port

DOWMAX ME motor

Performance data

Fluid: Shell tellus K46 (Viscosity 30cSt at 50°C)

The graphs shown are mean values obtained for production units.

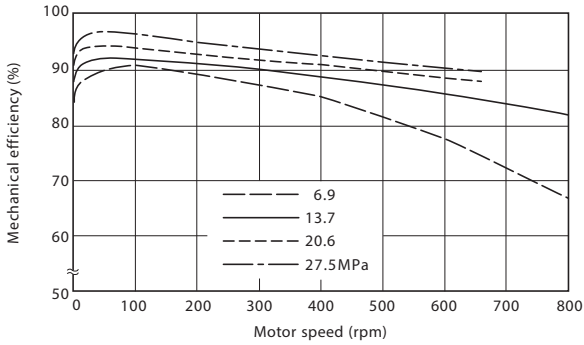

Fig. 1: Mechanical efficiency

Mechanical efficiency at various speeds is shown for 4 operating pressures.

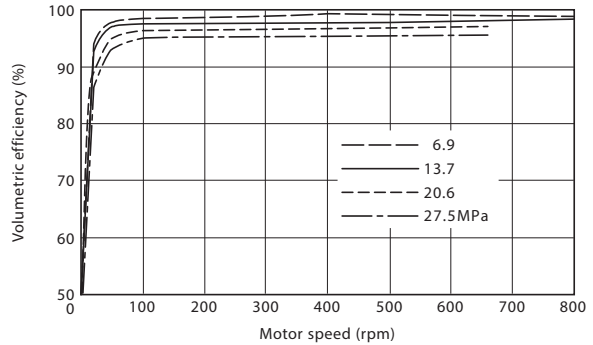

Fig. 2: Volumetric efficiency

Volumetric efficiency at various speeds is shown for 4 operating pressures.

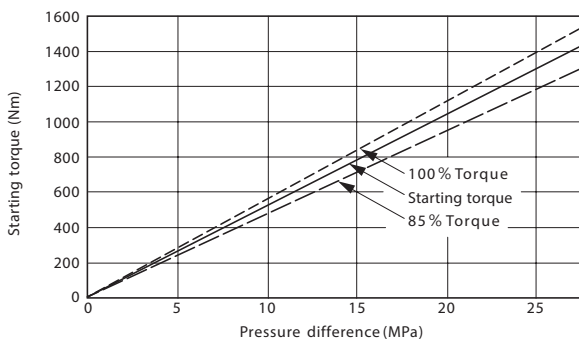

Fig. 3: Starting torque

Starting torque versus effective pressure is shown. Oil viscosity will not affect the starting torque efficiency.

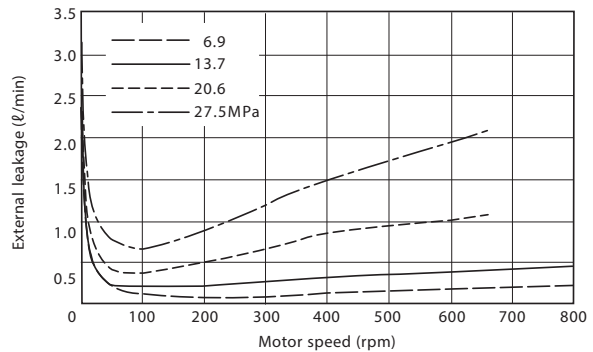

Fig. 4: External leakage

External leakage (from motor drain ports) relative to various speeds is shown for 4 operating pressures.

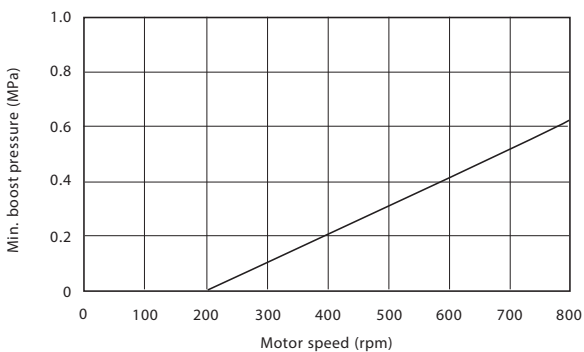

Fig. 5: Minimum boost pressure

It is important that sufficient inlet pressure is maintained, when the motor is operated as a pump or when the load overruns the motor, to prevent cavitation.

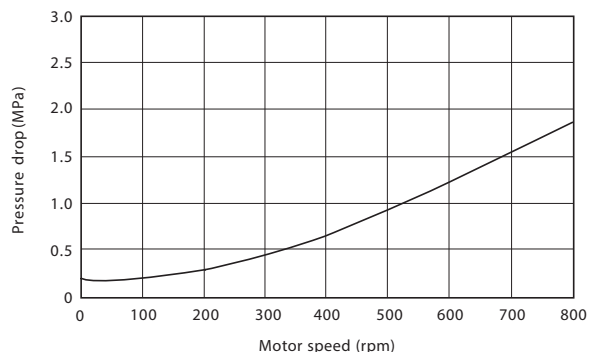

Fig. 6: Pressure drop

Pressure necessary to run motor without load is shown for various speeds.

DOWMAX ME motor

ME600B

(Dimensions in mm)

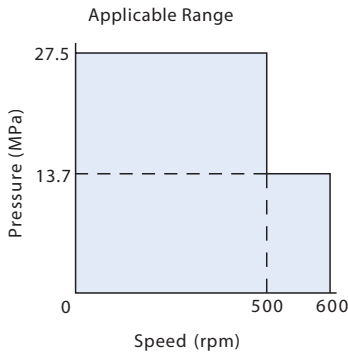

Displacement	600cm ³ /rev
Rated pressure	27.5MPa (280kgf/cm ²)
Peak pressure	31.9MPa (325kgf/cm ²)
Rated torque	2620Nm (267kgfm)
Rated speed	500rpm
Max. speed	600rpm
Rated horse power	137kW (186PS)
Mass	96kg

Nominal dimensions

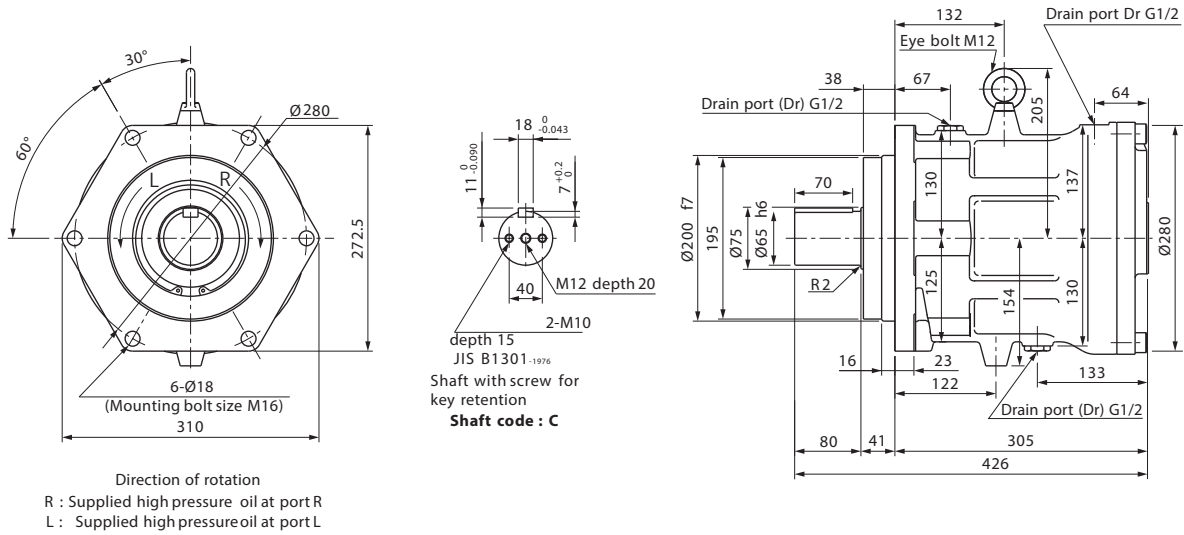

Splined shaft

Shaft code : P

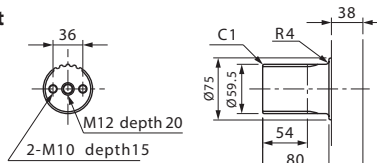

Tapered shaft (1/10 taper)

Shaft code : B (Single oil seal)

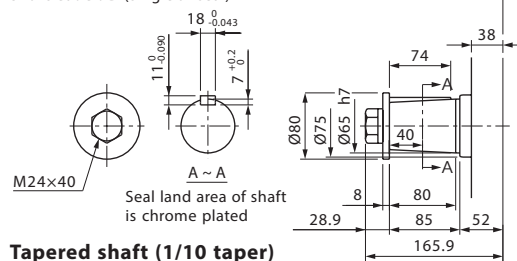

Tapered shaft (1/10 taper)

Shaft code : BW (Double oil seal)

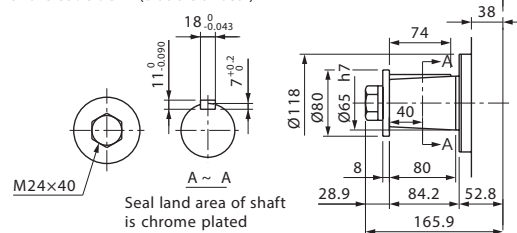

JIS D2001 Involute spline

60 × 22 × 2.5 (Class b)

Shaft	Coefficient of profile shifting	+ 0.800
	Tool	Tooth form Stub tooth
	Module	2.5
	Pressure angle	20°
	Number of teeth	22
	Grade	Class b (flank fit)
Tooth thickness	Overall, across a given number of teeth (reference)	64.516 ^{+0.020} _{-0.114}
	Outer dia.	Pin dia.=Ø4.5
	Inner dia.	54
	Coefficient of profile shifting	+ 0.800
Hole	Tool	Tooth form Stub tooth
	Module	2.5
	Pressure angle	20°
	Number of teeth	22
	Overall, across a given number of grooves (reference)	50.168 ^{+0.086} ₀
	Overall, displacement across a given number of grooves (reference)	Thickness of chamfered part=4.26
Tooth width	Outer dia.	60.75
	Inner dia.	55 ^{+0.030} ₀
	Overall, displacement across a given number of grooves (reference)	27.970 ^{+0.030} _{-0.009}

DOWMAX ME motor

Performance data

Fluid: Shell tellus K46 (Viscosity 30cSt at 50°C)

The graphs shown are mean values obtained for production units.

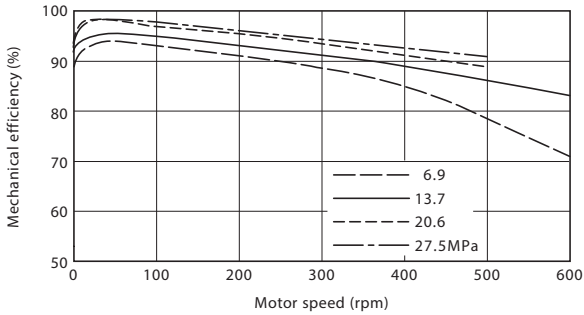

Fig. 1: Mechanical efficiency

Mechanical efficiency at various speeds is shown for 4 operating pressures.

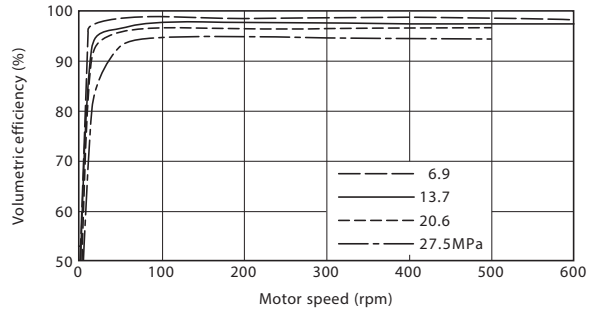

Fig. 2: Volumetric efficiency

Volumetric efficiency at various speeds is shown for 4 operating pressures.

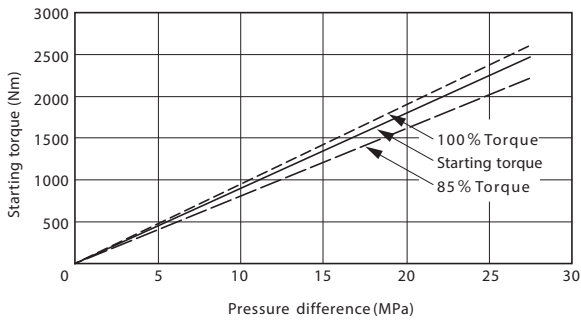

Fig. 3: Starting torque

Starting torque versus effective pressure is shown. Oil viscosity will not affect the starting torque efficiency.

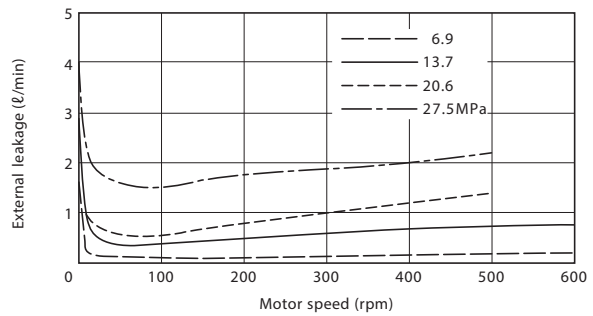

Fig. 4: External leakage

External leakage (from motor drain ports) relative to various speeds is shown for 4 operating pressures.

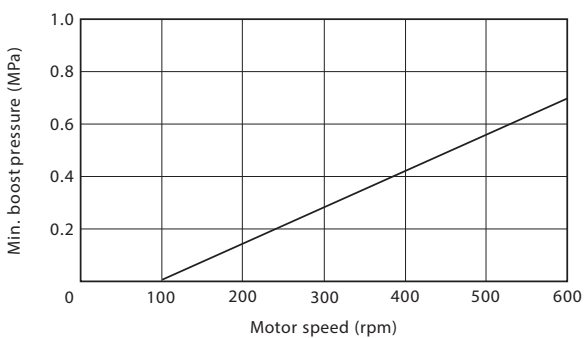

Fig. 5: Minimum boost pressure

It is important that sufficient inlet pressure is maintained, when the motor is operated as a pump or when the load overruns the motor, to prevent cavitation.

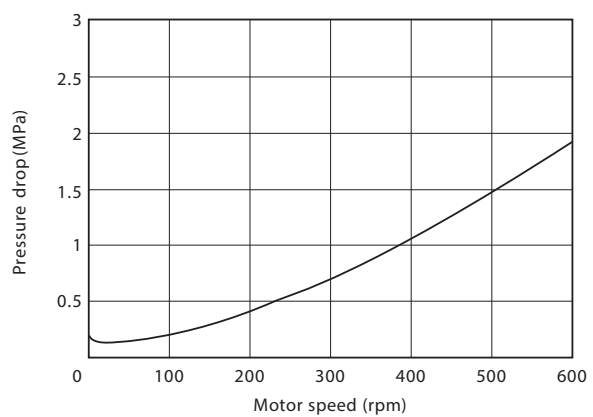

Fig. 6: Pressure drop

Pressure necessary to run motor without load is shown for various speeds.

DOWMAX ME motor

ME750B

(Dimensions in mm)

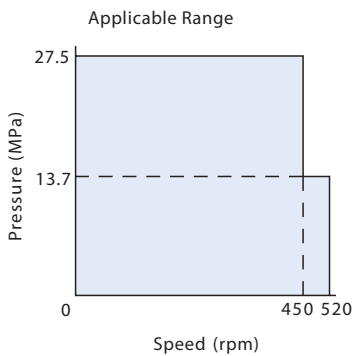

Displacement	750cm ³ /rev
Rated pressure	27.5MPa (280kgf/cm ²)
Peak pressure	31.9MPa (325kgf/cm ²)
Rated torque	3280Nm (334kgfm)
Rated speed	450rpm
Max. speed	520rpm
Rated horse power	154kW (210PS)
Mass	123kg

Nominal dimensions

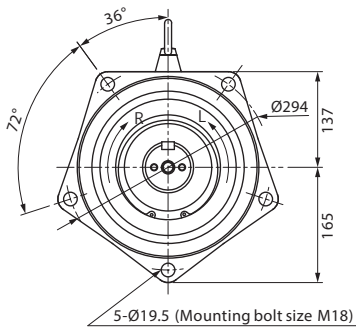

Direction of rotation

- R : Supplied high pressure oil at port R
- L : Supplied high pressure oil at port L

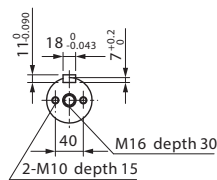

JIS B1301-1976
Shaft with screw for key retention
Shaft code : C

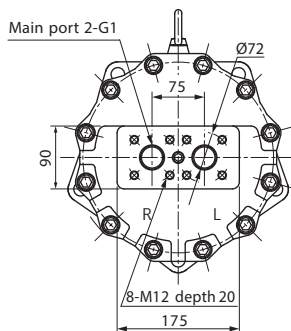
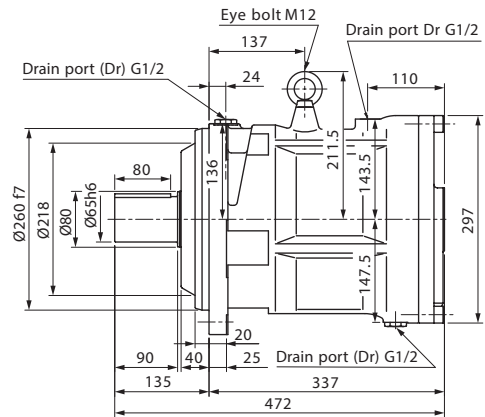

Splined shaft

Shaft code : P

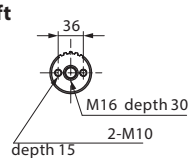

Tapered shaft (1/10 taper)

Shaft code : B (Single oil seal)

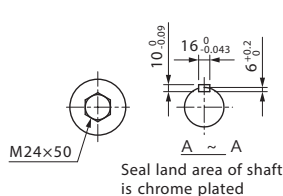

Tapered shaft (1/10 taper)

Shaft code : BW (Double oil seal)

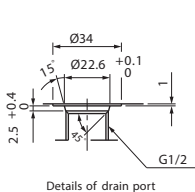
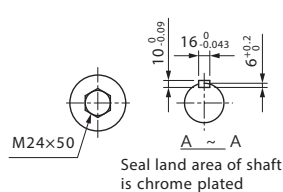

Details of drain port

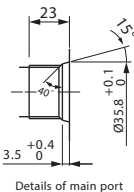

Details of main port

JIS D2001 Involute spline

60 × 22 × 2.5 (Class b)

Shaft	Coefficient of profile shifting	+ 0.800	
	Tool	Stub tooth	
	Tool	Module	2.5
	Pressure angle	20°	
	Number of teeth	22	
	Dia. of basic pitch circle	55	
	Grade	Class b (flank fit)	
	Over-pin dia.	64.516 ^{+0.020} _{-0.114}	
	Pin dia.	Ø4.5	
	Overall, across a given number of teeth (reference)	27.970 ^{+0.001} _{-0.058} (4-teeth)	
Outer dia.	59.5		
Inner dia.	54		
Hole	Coefficient of profile shifting	+ 0.800	
	Tool	Stub tooth	
	Tool	Module	2.5
	Pressure angle	20°	
	Number of teeth	22	
	Dia. of basic pitch circle	55	
	Over-pin dia.	50.168 ^{+0.086} ₋₀	
	Pin dia.	Ø5	
	Thickness of chamfered part	4.26	
	Overall, displacement across a given number of grooves (reference)	27.970 ^{+0.030} _{-0.009} (4-teeth)	
Outer dia.	60.75		
Inner dia.	55 ^{+0.030} ₀		

DOWMAX ME motor

Performance data

Fluid: Shell tellus K46 (Viscosity 30cSt at 50°C)

The graphs shown are mean values obtained for production units.

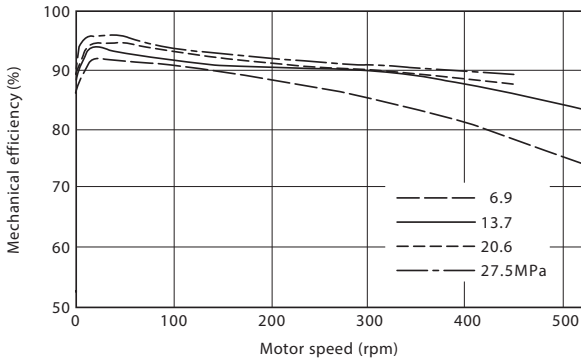

Fig. 1: Mechanical efficiency

Mechanical efficiency at various speeds is shown for 4 operating pressures.

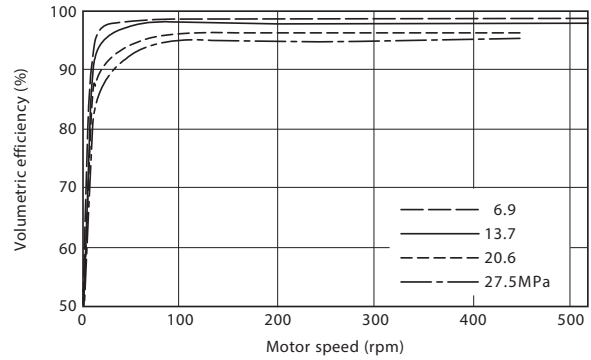

Fig. 2: Volumetric efficiency

Volumetric efficiency at various speeds is shown for 4 operating pressures.

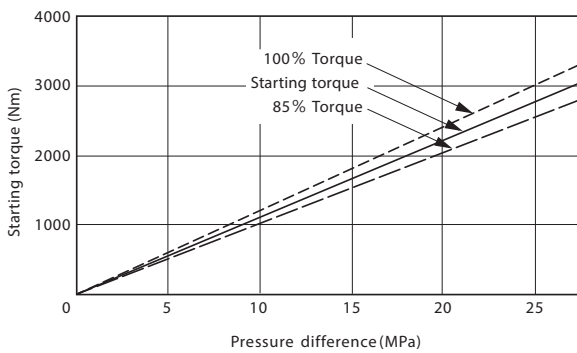

Fig. 3: Starting torque

Starting torque versus effective pressure is shown. Oil viscosity will not affect the starting torque efficiency.

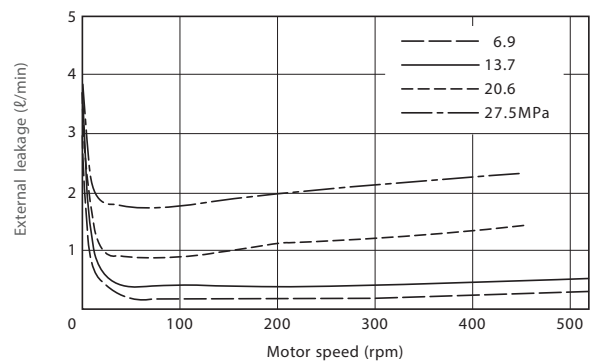

Fig. 4: External leakage

External leakage (from motor drain ports) relative to various speeds is shown for 4 operating pressures.

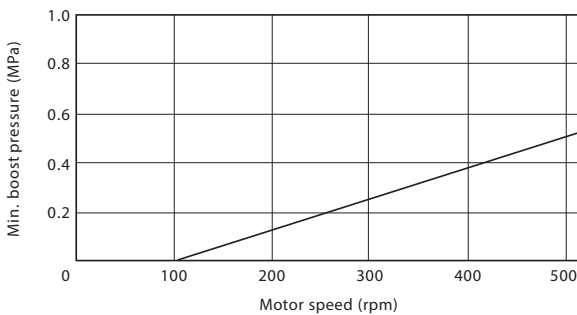

Fig. 5: Minimum boost pressure

It is important that sufficient inlet pressure is maintained, when the motor is operated as a pump or when the load overruns the motor, to prevent cavitation.

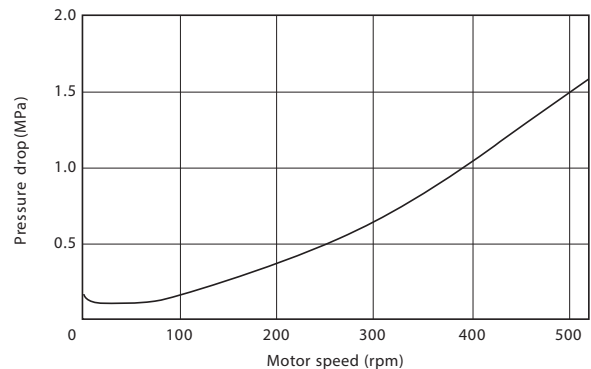

Fig. 6: Pressure drop

Pressure necessary to run motor without load is shown for various speeds.

DOWMAX ME motor

ME850B

(Dimensions in mm)

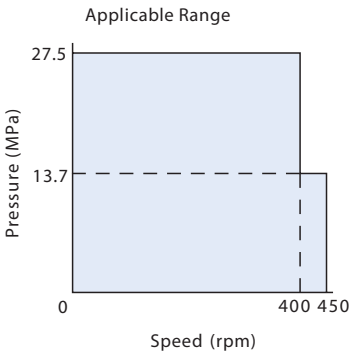

Displacement	848cm ³ /rev
Rated pressure	27.5MPa (280kgf/cm ²)
Peak pressure	31.9MPa (325kgf/cm ²)
Rated torque	3708Nm (378kgfm)
Rated speed	400rpm
Max. speed	450rpm
Rated horse power	155kW (211PS)
Mass	123kg

Nominal dimensions

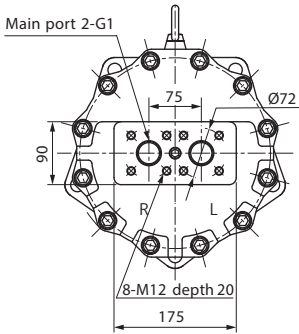
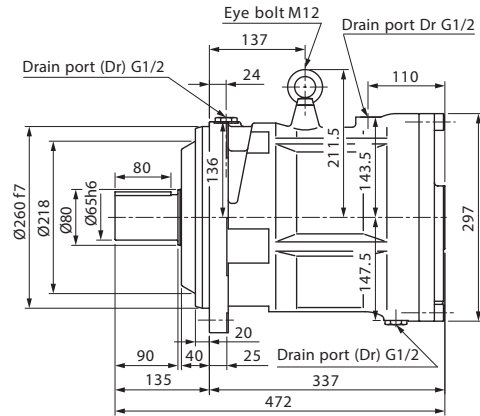
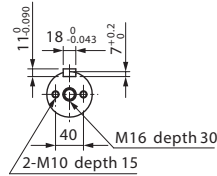
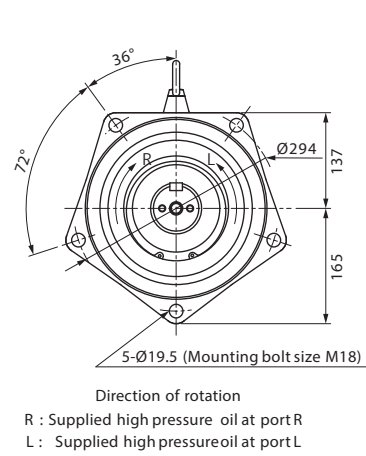

Splined shaft

Shaft code : P

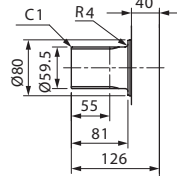
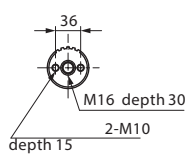

Tapered shaft (1/10 taper)

Shaft code : B (Single oil seal)

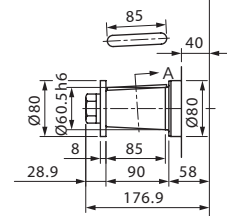
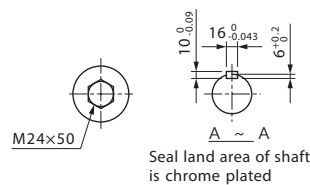

Tapered shaft (1/10 taper)

Shaft code : BW (Double oil seal)

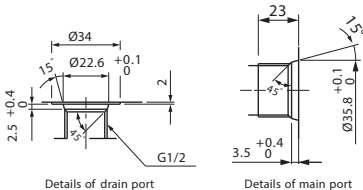
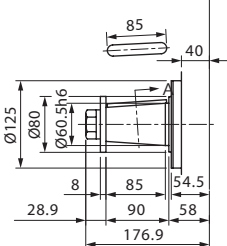
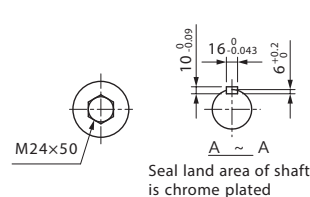

JIS D2001 Involute spline

60 × 22 × 2.5 (Class b)

Shaft	Coefficient of profile shifting	
	Tool	+ 0.800
Tooth thickness	Tooth form	Stub tooth
	Module	2.5
Tooth thickness	Pressure angle	20°
	Number of teeth	22
Tooth thickness	Dia. of basic pitch circle	55
	Grade	Class b (flank fit)
Tooth thickness	Over-pin dia.	64.516 ^{+0.020} _{-0.114}
	Overall, across a given number of teeth (reference)	Pin dia.=Ø4.5 27.970 ^{-0.001} _{-0.058} (4-teeth)
Tooth thickness	Outer dia.	59.5
	Inner dia.	54
Hole	Coefficient of profile shifting	
	Tool	+ 0.800
Tooth width	Tooth form	Stub tooth
	Module	2.5
Tooth width	Pressure angle	20°
	Number of teeth	22
Tooth width	Dia. of basic pitch circle	55
	Over-pin dia.	50.168 ^{+0.086} ₋₀ Pin dia.=Ø5 Thickness of chamfered part=4.26
Tooth width	Overall, displacement across a given number of grooves (reference)	27.970 ^{+0.030} _{-0.009} (4-teeth)
	Outer dia.	60.75
Tooth width	Inner dia.	55 ^{+0.030} ₀

DOWMAX ME motor

Performance data

Fluid: Shell tellus K46 (Viscosity 30cSt at 50°C)

The graphs shown are mean values obtained for production units.

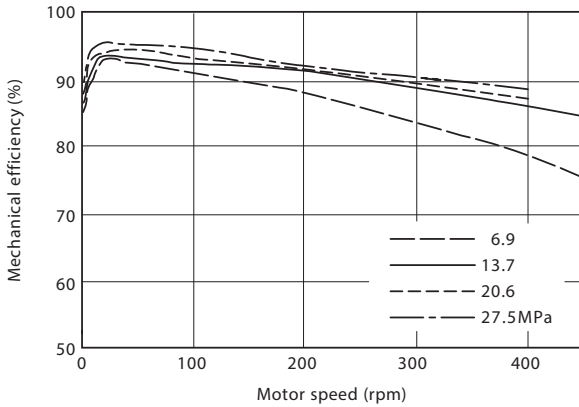

Fig. 1: Mechanical efficiency

Mechanical efficiency at various speeds is shown for 4 operating pressures.

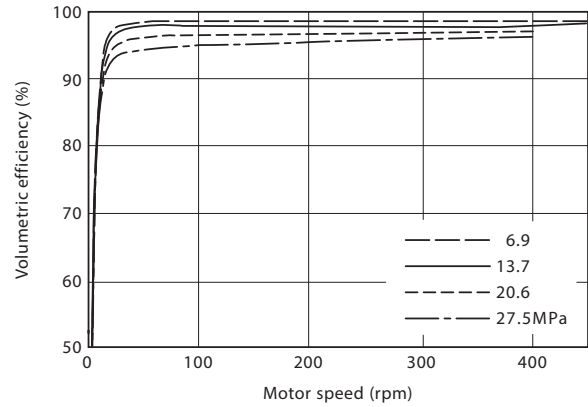

Fig. 2: Volumetric efficiency

Volumetric efficiency at various speeds is shown for 4 operating pressures.

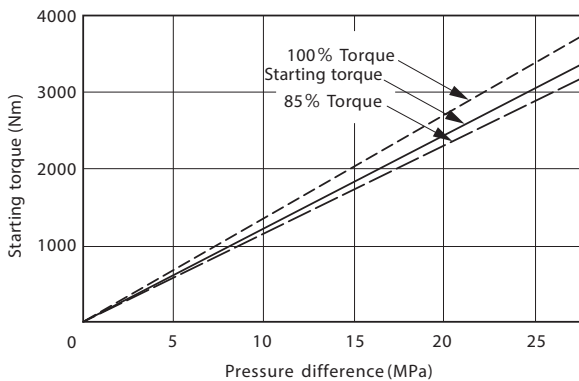

Fig. 3: Starting torque

Starting torque versus effective pressure is shown. Oil viscosity will not affect the starting torque efficiency.

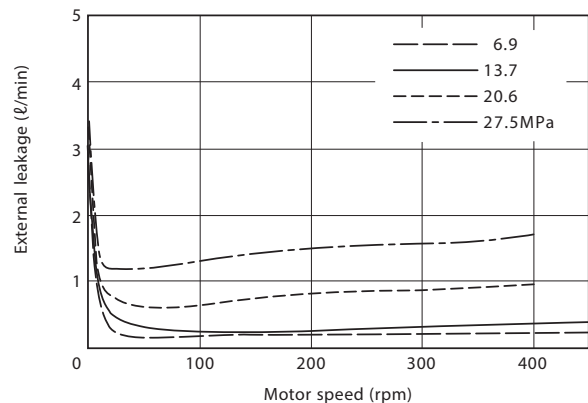

Fig. 4: External leakage

External leakage (from motor drain ports) relative to various speeds is shown for 4 operating pressures.

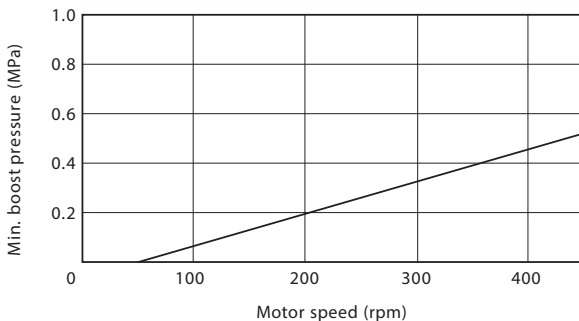

Fig. 5: Minimum boost pressure

It is important that sufficient inlet pressure is maintained, when the motor is operated as a pump or when the load overruns the motor, to prevent cavitation.

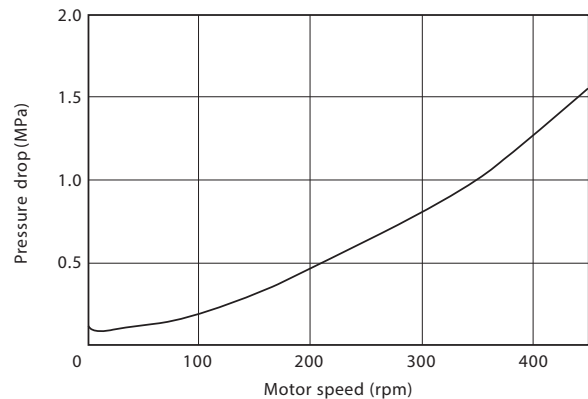

Fig. 6: Pressure drop

Pressure necessary to run motor without load is shown for various speeds.

DOWMAX ME motor

ME1300A

(Dimensions in mm)

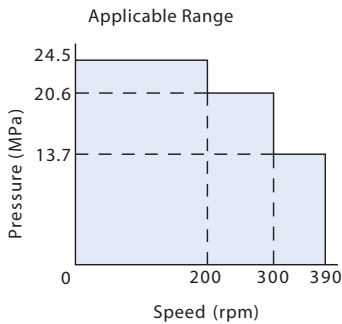

Displacement	1345cm ³ /rev
Rated pressure	24.5MPa (250kgf/cm ²)
Peak pressure	31.9MPa (325kgf/cm ²)
Rated torque	5250Nm (535kgfm)
Rated speed	200rpm
Max. speed	390rpm
Rated horse power	138kW (188PS)
Mass	170kg

Nominal dimensions

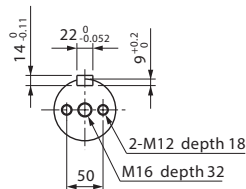
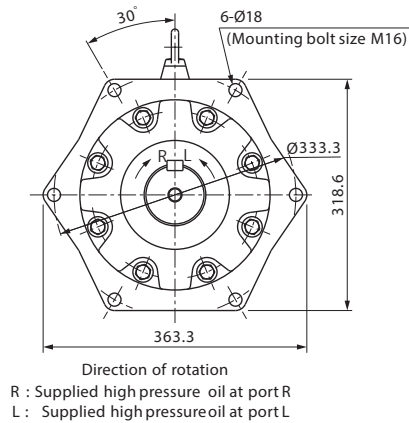

JIS B1301-1976
Shaft with screw for key retention
Shaft code : C

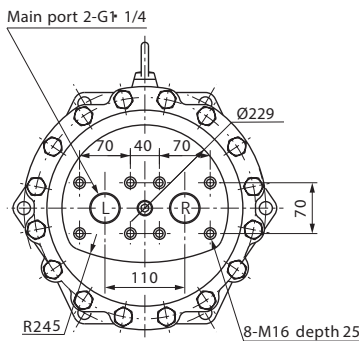
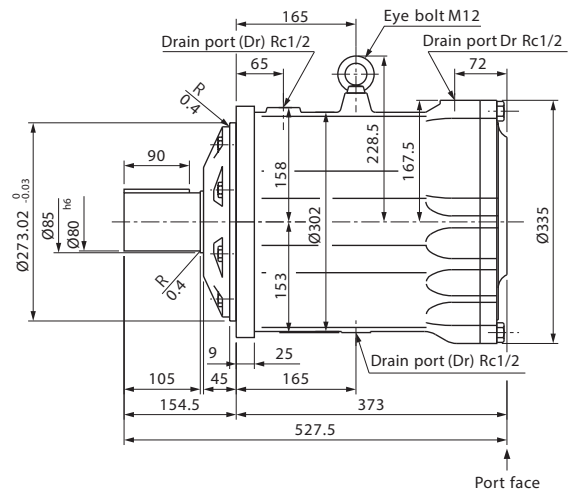

Splined shaft
Shaft code : P

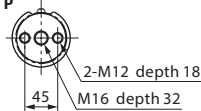

Tapered shaft (1/10 taper)
Shaft code : B (Single oil seal)

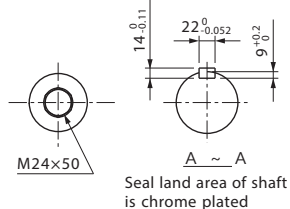

Tapered shaft (1/10 taper)
Shaft code : BW (Double oil seal oil seal)

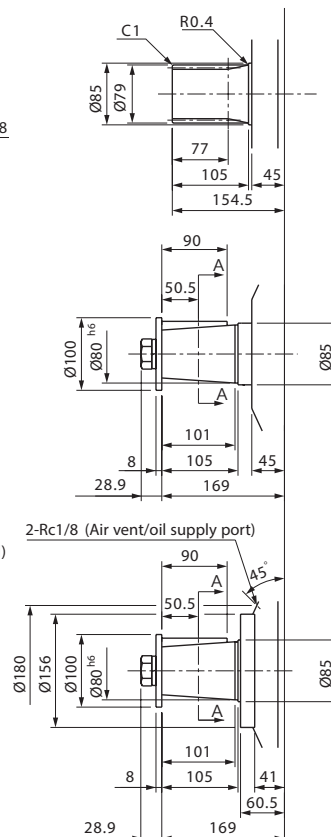
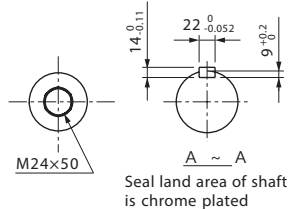

JIS D2001 Involute spline
80 × 14 × 5 (Class b)

Shaft	Coefficient of profile shifting	+ 0.800	
	Tool	Tooth form	Stub tooth
		Module	5
	Pressure angle	20°	
	Number of teeth	14	
	Shaft thickness	Grade	Class b (flank fit)
		Over-pin dia.	88.346 ^{+0.029} _{-0.154}
	Tooth thickness	Pin dia.=Ø9	
		Overall, across a given number of teeth (reference)	40.618 ^{+0.002} _{-0.086} (3-teeth)
	Outer dia.	79	
Inner dia.	68		
Hole	Coefficient of profile shifting	+ 0.800	
	Tool	Tooth form	Stub tooth
		Module	5
	Pressure angle	20°	
	Number of teeth	14	
	Tooth width	Over-pin dia.	60.335 ^{+0.121} ₀ Pin dia.=Ø10 Thickness of chamfered part=8.4
		Overall displacement across a given number of grooves (reference)	40.618 ^{+0.043} ₀ (3-teeth)
	Outer dia.	81.5	
	Inner dia.	70 ^{+0.030} ₀	

DOWMAX ME motor

Performance data

Fluid: Shell tellus 56 (Viscosity 37cSt at 50°C)

The graphs shown are mean values obtained for production units.

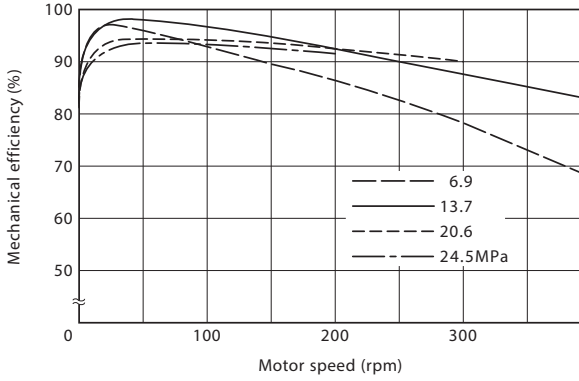

Fig. 1: Mechanical efficiency

Mechanical efficiency at various speeds is shown for 4 operating pressures.

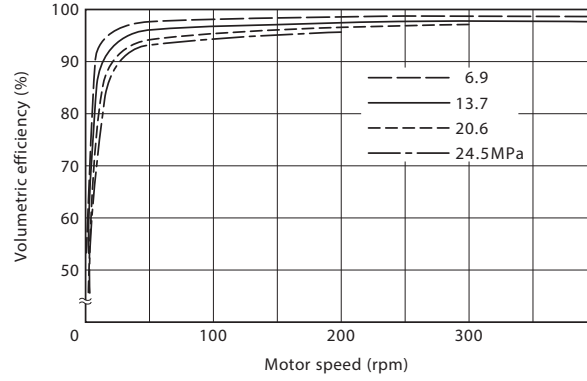

Fig. 2: Volumetric efficiency

Volumetric efficiency at various speeds is shown for 4 operating pressures.

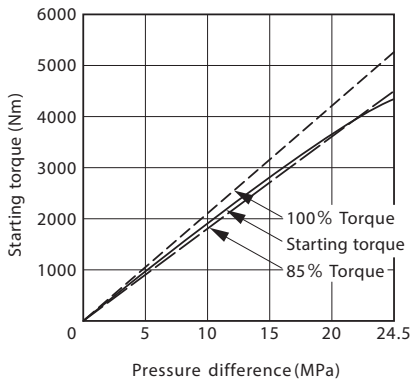

Fig. 3: Starting torque

Starting torque versus effective pressure is shown. Oil viscosity will not affect the starting torque efficiency.

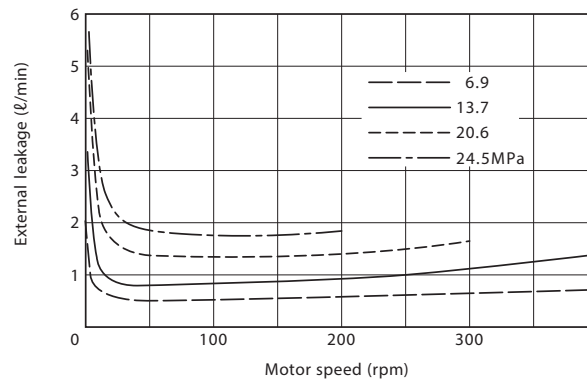

Fig. 4: External leakage

External leakage (from motor drain ports) relative to various speeds is shown for 4 operating pressures.

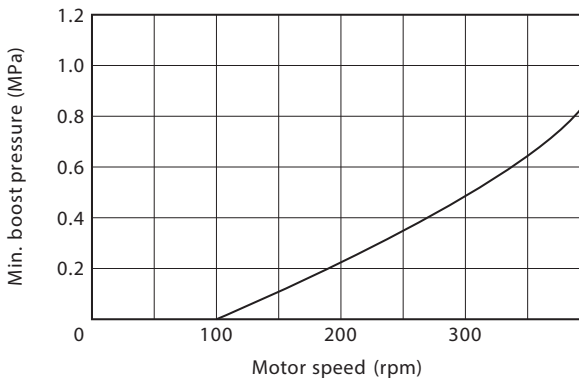

Fig. 5: Minimum boost pressure

It is important that sufficient inlet pressure is maintained, when the motor is operated as a pump or when the load overruns the motor, to prevent cavitation.

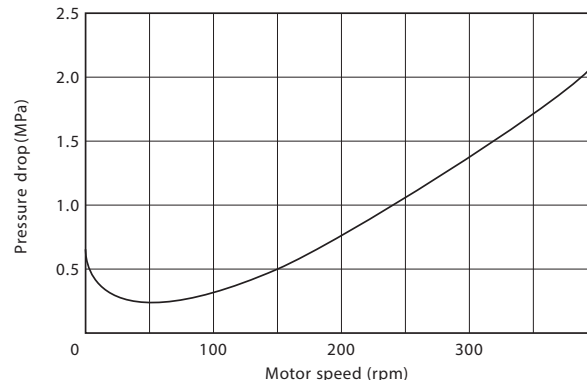

Fig. 6: Pressure drop

Pressure necessary to run motor without load is shown for various speeds.

DOWMAX ME motor

ME1900

(Dimensions in mm)

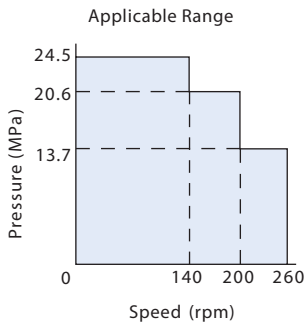

Displacement	1868cm ³ /rev
Rated pressure	24.5MPa (250kgf/cm ²)
Peak pressure	31.9MPa (325kgf/cm ²)
Rated torque	7290Nm (743kgfm)
Rated speed	140rpm
Max. speed	260rpm
Rated horse power	128kW (174PS)
Mass	270kg

Nominal dimensions

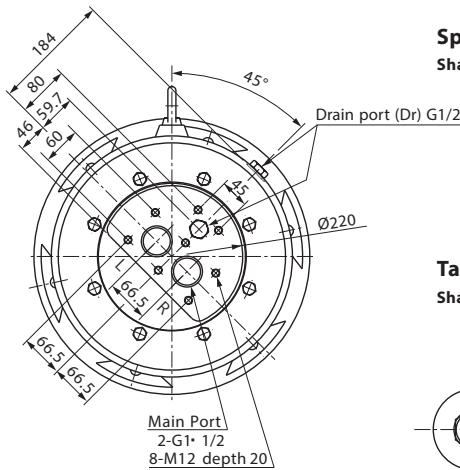
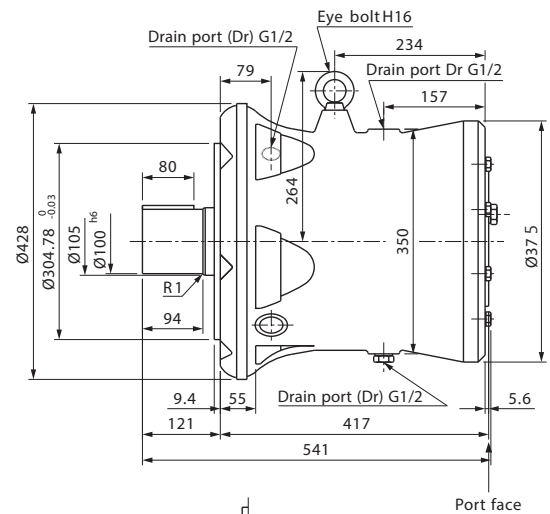
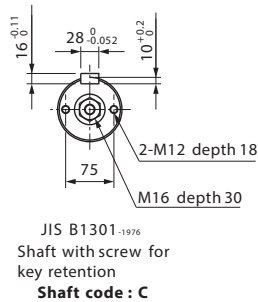
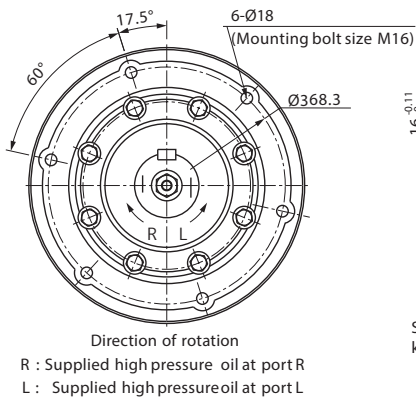

Splined shaft

Shaft code : P

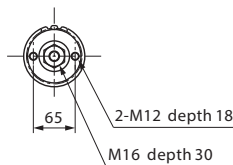

Tapered shaft (1/10 taper)

Shaft code : B (Single oil seal)

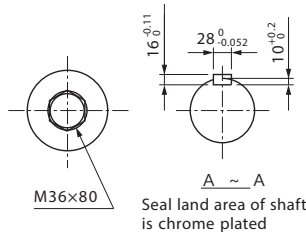

Tapered shaft (1/10 taper)

Shaft code : BW (Double oil seal)

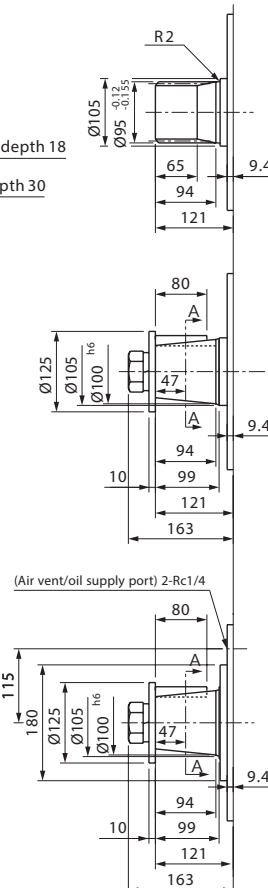
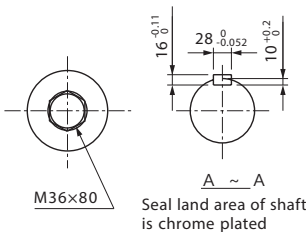

JIS D2001 Involute spline

95 × 17 × 5 (Class a)

Shaft	Coefficient of profile shifting	+ 0.800	
	Tool	Tooth form	Stub tooth
		Module	5
	Pressure angle	20°	
	Number of teeth	17	
	Shaft thickness	Dia. of basic pitch circle	85
		Grade	Class a (major dia. fit)
	Tooth thickness	Over-pin dia.	103.242 ^{-0.176} _{-0.306}
		Pin dia.=Ø9	
	Tooth thickness	Over-all, across a given number of teeth (reference)	40.828 ^{-0.084} _{-0.165} (3-teeth)
Outer dia.		95 ^{-0.12} _{-0.155}	
Inner dia.	83		
Hole	Coefficient of profile shifting	+ 0.800	
	Tool	Tooth form	Stub tooth
		Module	5
	Pressure angle	20°	
	Number of teeth	17	
	Tooth width	Dia. of basic pitch circle	85
		Over-pin dia.	74.972 ^{+0.122} ₀ Pin dia.=Ø10 Thickness of chamfered part=8.4
	Tooth width	Over-all, Displacement across a given number of grooves (reference)	40.828 ^{+0.043} _{-0.011} (3-teeth)
		Outer dia.	95 ^{-0.038} _{-0.073}
	Inner dia.	85 ^{+0.035} ₀	

DOWMAX ME motor

Performance data

Fluid: Shell tellus 56 (Viscosity 37cSt at 50°C)

The graphs shown are mean values obtained for production units.

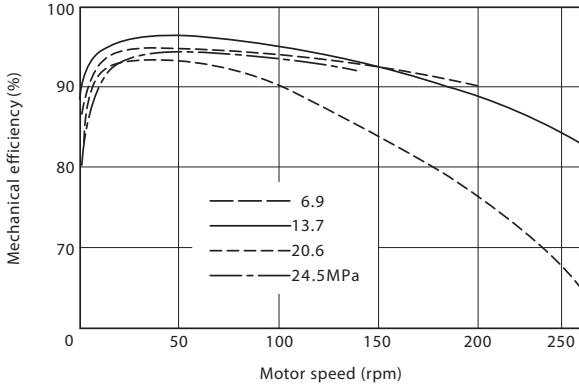

Fig. 1: Mechanical efficiency

Mechanical efficiency at various speeds is shown for 4 operating pressures.

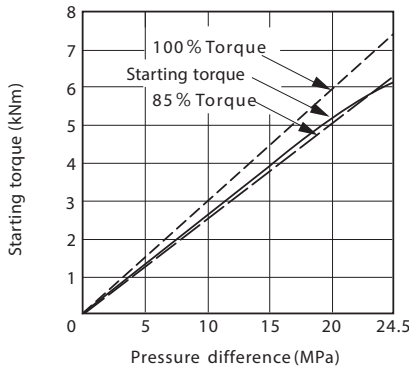

Fig. 3: Starting torque

Starting torque versus effective pressure is shown. Oil viscosity will not affect the starting torque efficiency.

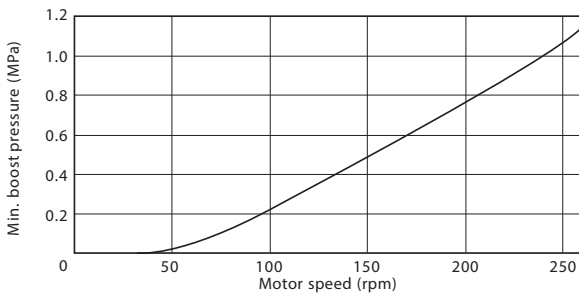

Fig. 5: Minimum boost pressure

It is important that sufficient inlet pressure is maintained, when the motor is operated as a pump or when the load overruns the motor, to prevent cavitation.

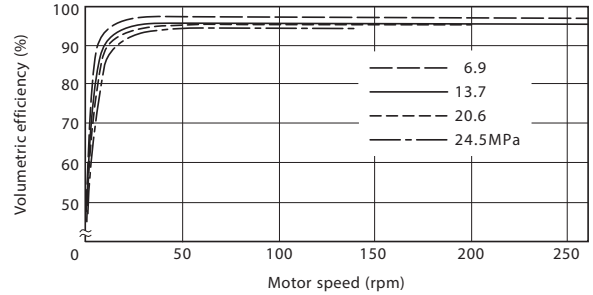

Fig. 2: Volumetric efficiency

Volumetric efficiency at various speeds is shown for 4 operating pressures.

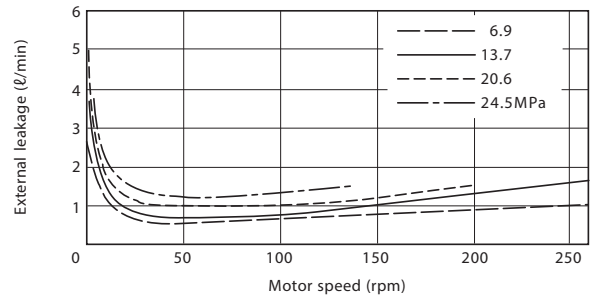

Fig. 4: External leakage

External leakage (from motor drain ports) relative to various speeds is shown for 4 operating pressures.

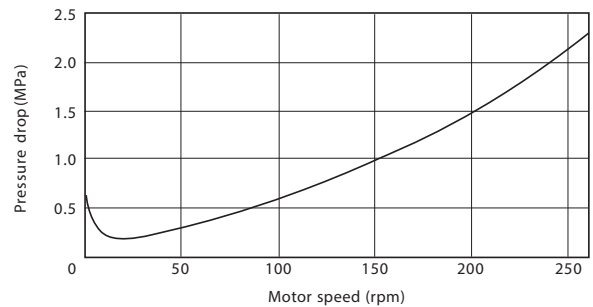

Fig. 6: Pressure drop

Pressure necessary to run motor without load is shown for various speeds.

DOWMAX ME motor

ME2600

(Dimensions in mm)

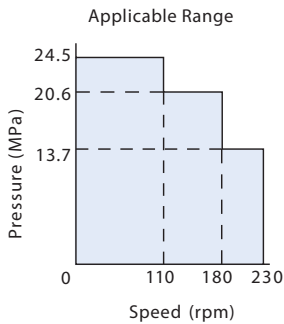

Displacement	2578cm ³ /rev
Rated pressure	24.5MPa (250kgf/cm ²)
Peak pressure	31.9MPa (325kgf/cm ²)
Rated torque	10060Nm (1026kgfm)
Rated speed	110rpm
Max. speed	230rpm
Rated horse power	159kW (216PS)
Mass	350kg

Nominal dimensions

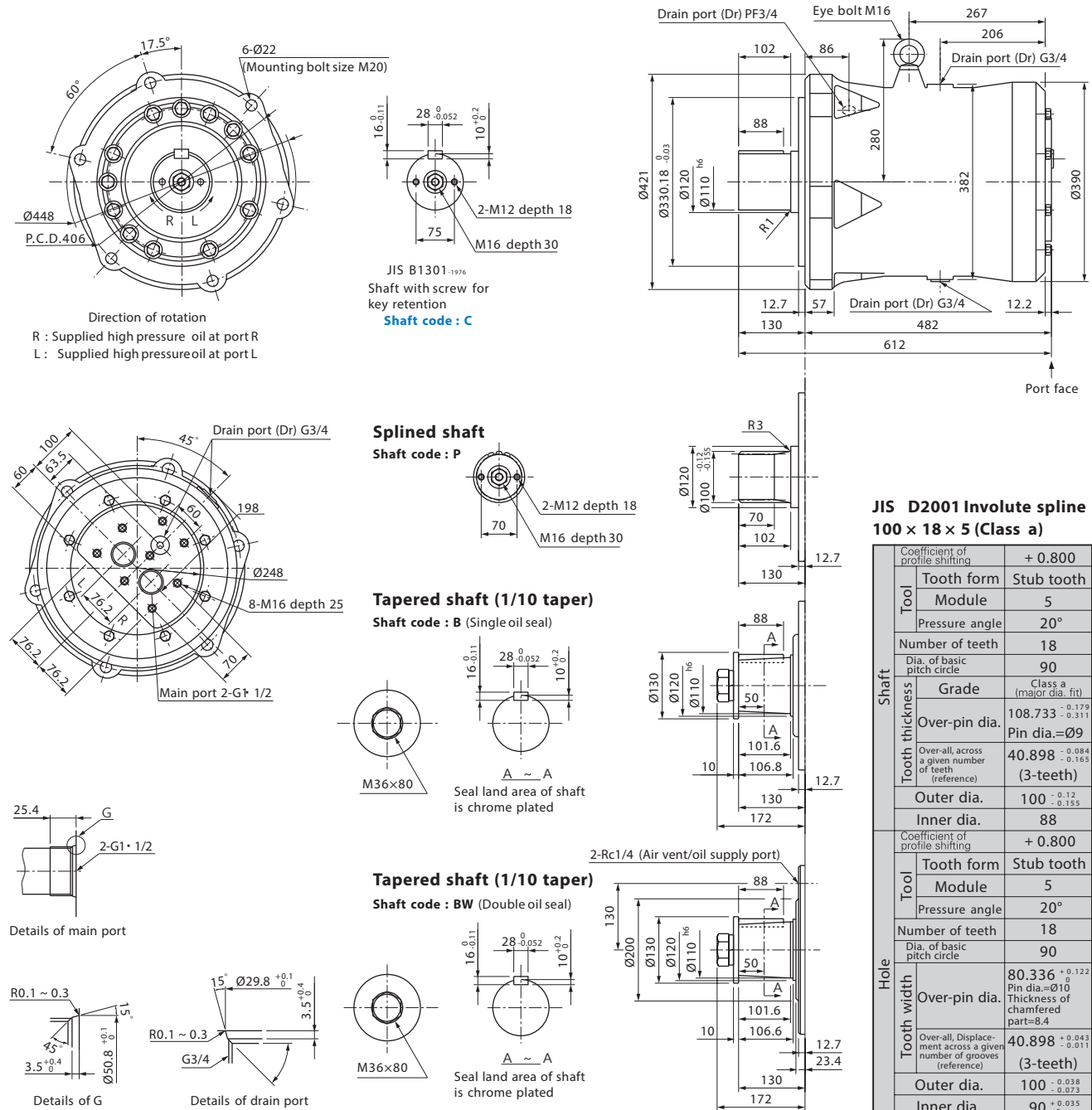

DOWMAX ME motor

Performance data

Fluid: Shell tellus 56 (Viscosity 37cSt at 50°C)

The graphs shown are mean values obtained for production units.

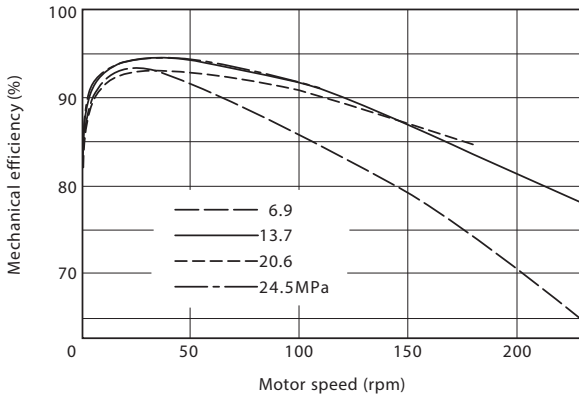

Fig. 1: Mechanical efficiency

Mechanical efficiency at various speeds is shown for 4 operating pressures.

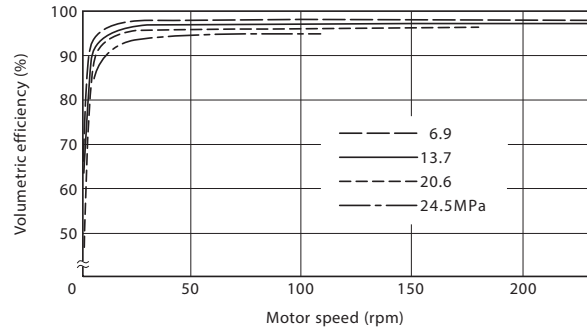

Fig. 2: Volumetric efficiency

Volumetric efficiency at various speeds is shown for 4 operating pressures.

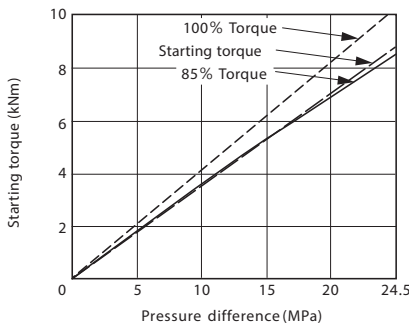

Fig. 3: Starting torque

Starting torque versus effective pressure is shown. Oil viscosity will not affect the starting torque efficiency.

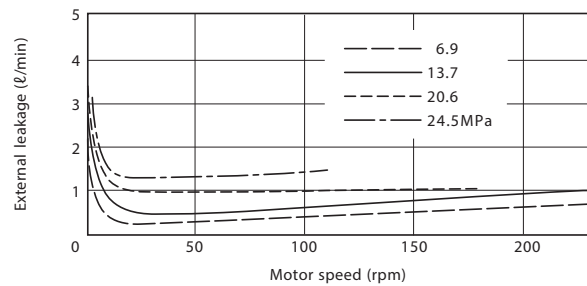

Fig. 4: External leakage

External leakage (from motor drain ports) relative to various speeds is shown for 4 operating pressures.

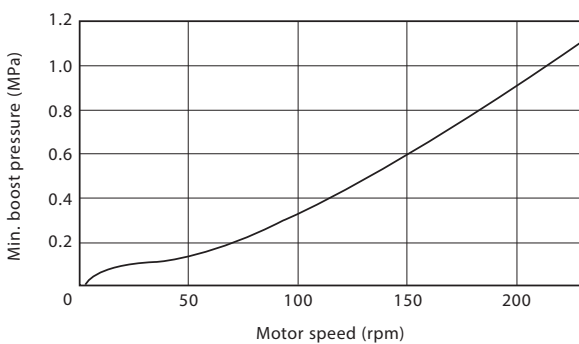

Fig. 5: Minimum boost pressure

It is important that sufficient inlet pressure is maintained, when the motor is operated as a pump or when the load overruns the motor, to prevent cavitation.

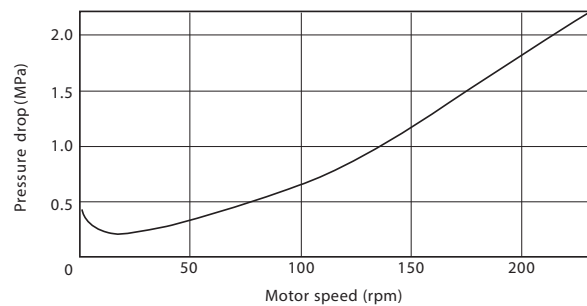

Fig. 6: Pressure drop

Pressure necessary to run motor without load is shown for various speeds.

DOWMAX ME motor

ME3100

(Dimensions in mm)

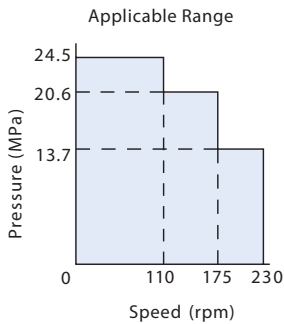

Displacement	3104cm ³ /rev
Rated pressure	24.5MPa (250kgf/cm ²)
Peak pressure	31.9MPa (325kgf/cm ²)
Rated torque	12110Nm (1235kgfm)
Rated speed	110rpm
Max. speed	230rpm
Rated horse power	186kW (253PS)
Mass	364kg

Nominal dimensions

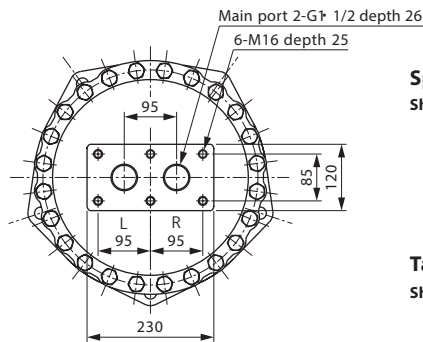
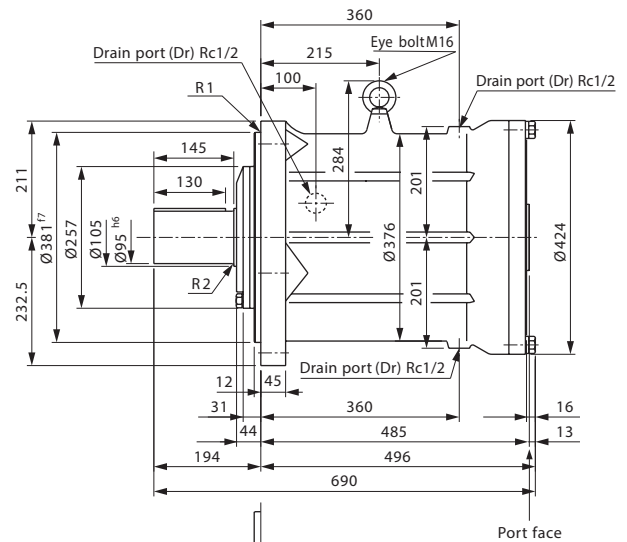
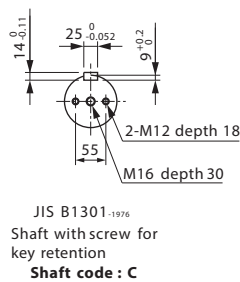
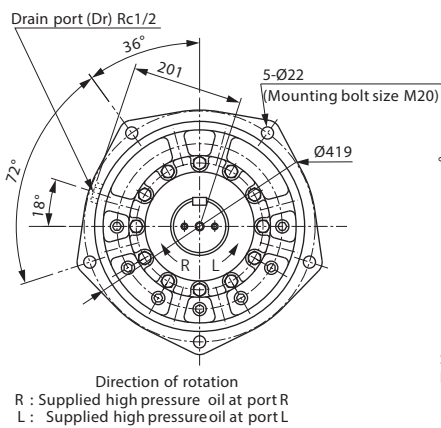

Splined shaft

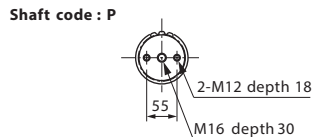

Tapered shaft (1/10 taper)

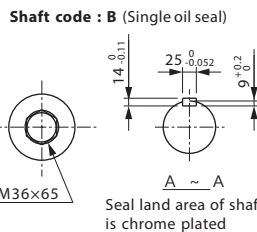

Tapered shaft (1/10 taper)

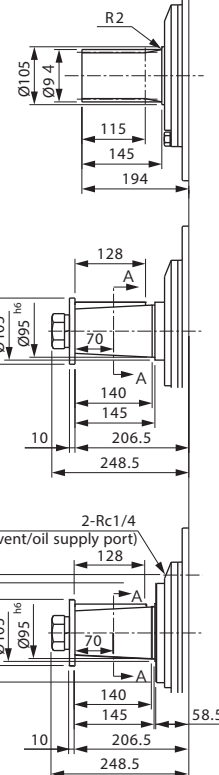
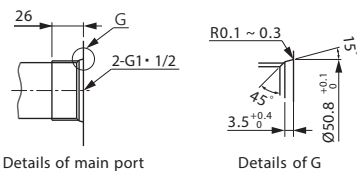
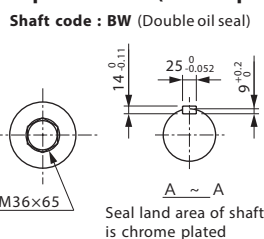

JIS D2001 Involute spline

		Coefficient of profile shifting		
Shaft	Tool	Tooth form	Stub tooth	
		Module	5	
	Pressure angle		20°	
	Number of teeth		17	
Shaft thickness	Dia. of basic pitch circle		85	
	Grade	Class b (flank fit)		
	Over-pin dia.	103.242 ^{+0.030} _{-0.160}		
	Pin dia.=Ø9		Pin dia.=Ø9	
Tooth thickness	Overall, across a given number of teeth (reference)		40.828 ^{+0.005} _{-0.086}	
	(3-teeth)		(3-teeth)	
	Outer dia.	94		
Inner dia.		83		
Hole	Coefficient of profile shifting		+ 0.800	
	Tool	Tooth form	Stub tooth	
		Module	5	
	Pressure angle		20°	
Number of teeth		17		
Tooth width	Dia. of basic pitch circle		85	
	Over-pin dia.	74.972 ^{+0.122} _{-0.011}		
	Pin dia.=Ø10		Pin dia.=Ø10	
	Thickness of chamfered part=8.4		Thickness of chamfered part=8.4	
Tooth thickness	Overall, displacement across a given number of grooves (reference)		40.828 ^{+0.043} _{-0.011}	
	(3-teeth)		(3-teeth)	
	Outer dia.	96.5		
Inner dia.		85 ^{+0.035} ₀		

DOWMAX ME motor

Performance data

Fluid: Shell tellus 56 (Viscosity 37cSt at 50°C)

The graphs shown are mean values obtained for production units.

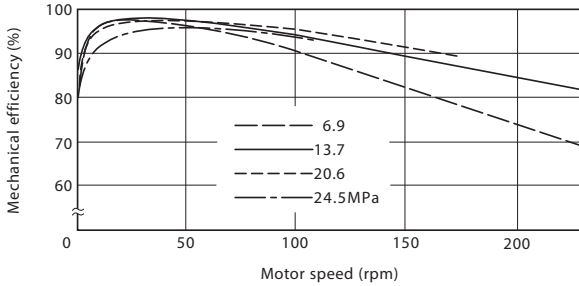

Fig. 1: Mechanical efficiency

Mechanical efficiency at various speeds is shown for 4 operating pressures.

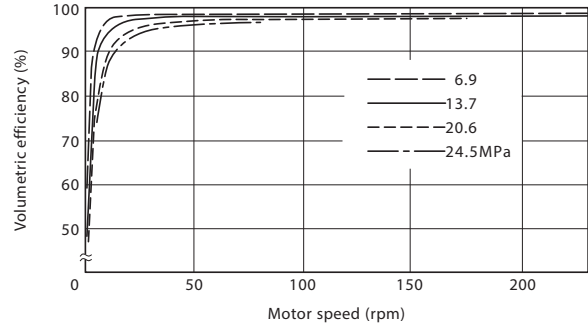

Fig. 2: Volumetric efficiency

Volumetric efficiency at various speeds is shown for 4 operating pressures.

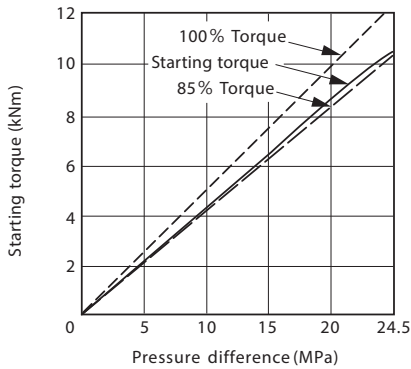

Fig. 3: Starting torque

Starting torque versus effective pressure is shown. Oil viscosity will not affect the starting torque efficiency.

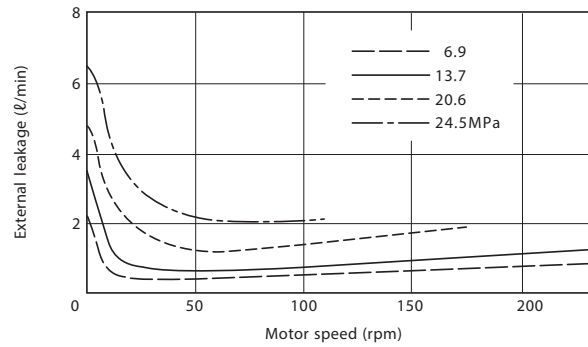

Fig. 4: External leakage

External leakage (from motor drain ports) relative to various speeds is shown for 4 operating pressures.

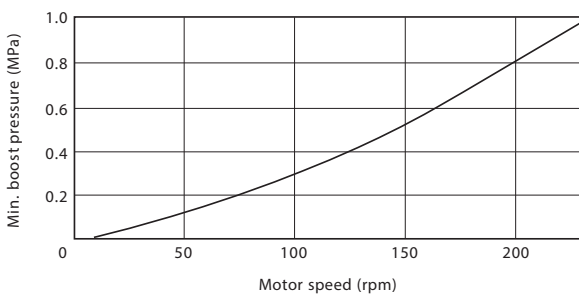

Fig. 5: Minimum boost pressure

It is important that sufficient inlet pressure is maintained, when the motor is operated as a pump or when the load overruns the motor, to prevent cavitation.

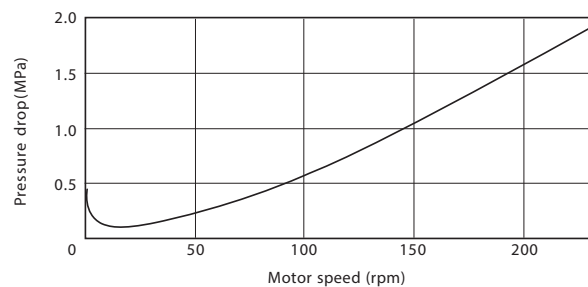

Fig. 6: Pressure drop

Pressure necessary to run motor without load is shown for various speeds.

DOWMAX ME motor

ME4100

(Dimensions in mm)

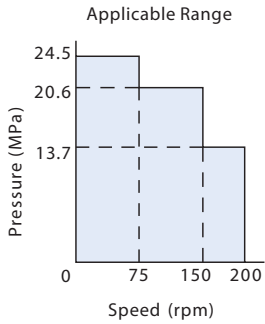

Displacement	4097cm ³ /rev
Rated pressure	24.5MPa (250kgf/cm ²)
Peak pressure	31.9MPa (325kgf/cm ²)
Rated torque	15990Nm (1630kgfm)
Rated speed	75rpm
Max. speed	200rpm
Rated horse power	211kW (287PS)
Mass	520kg

Nominal dimensions

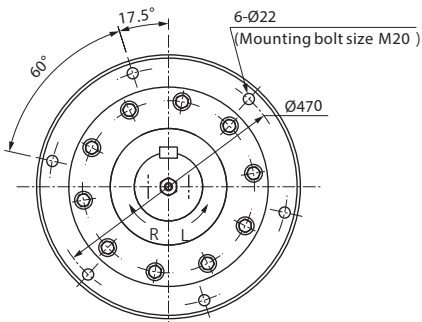

Direction of rotation
 R : Supplied high pressure oil at port R
 L : Supplied high pressure oil at port L

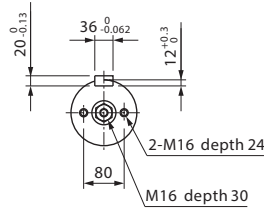

JIS B1301-1976
 Shaft with screw for key retention
Shaft code : C

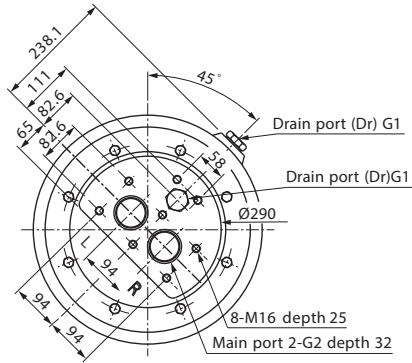
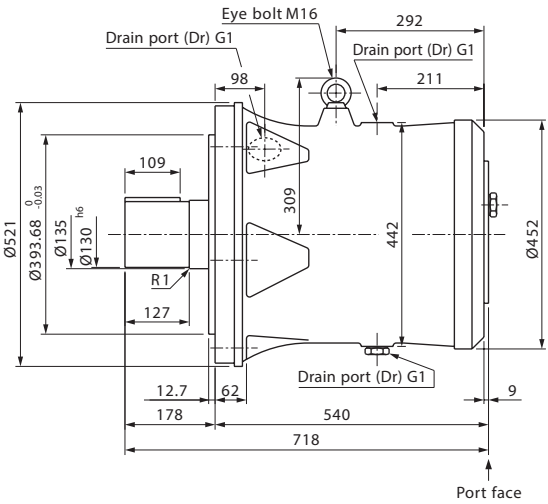

Splined shaft

Shaft code : P

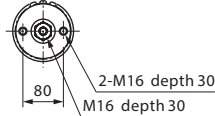

Tapered shaft (1/10 taper)

Shaft code : B (Single oil seal)

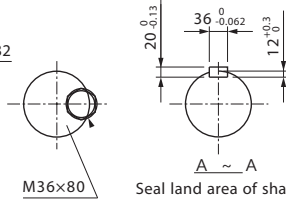

Tapered shaft (1/10 taper)

Shaft code : BW (Double oil seal)

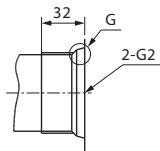
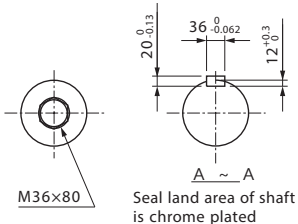

Details of main port

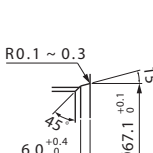

Details of G

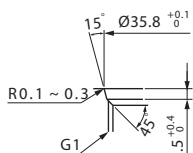

Details of drain port

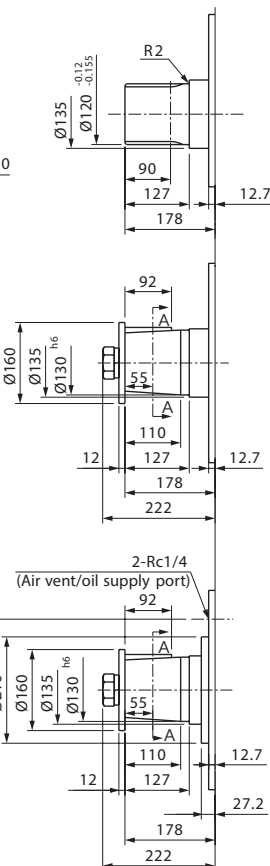

JIS D2001 Involute spline 120 × 22 × 5 (Class a)

Shaft	Coefficient of profile shifting	+ 0.800	
	Tool	Tooth form	Stub tooth
		Module	5
	Tooth thickness	Pressure angle	20°
		Number of teeth	22
	Tooth thickness	Dia. of basic pitch circle	110
		Grade	Class a (major dia. fit)
		Over-pin dia.	129.032 ^{+0.187} _{-0.325}
		Pin dia.=Ø9	55.939 ^{-0.084} _{-0.165}
	Tooth thickness	Over-all, across a given number of teeth (reference)	(4-teeth)
Outer dia.		120 ^{-0.12} _{-0.155}	
Tooth thickness	Inner dia.	108	
	Coefficient of profile shifting	+ 0.800	
Hole	Tool	Tooth form	Stub tooth
		Module	5
	Tooth thickness	Pressure angle	20°
		Number of teeth	22
	Tooth thickness	Dia. of basic pitch circle	110
		Over-pin dia.	100.337 ^{+0.123} ₀
		Pin dia.=Ø10	Thickness of chamfered part=8.4
		Over-all, Displacement across a given number of grooves (reference)	55.939 ^{+0.043} _{-0.011}
	Tooth thickness	Outer dia.	120 ^{-0.041} _{-0.076}
		Inner dia.	110 ^{+0.035} ₀

DOWMAX ME motor

Performance data

Fluid: Shell tellus 56 (Viscosity 37cSt at 50°C)

The graphs shown are mean values obtained for production units.

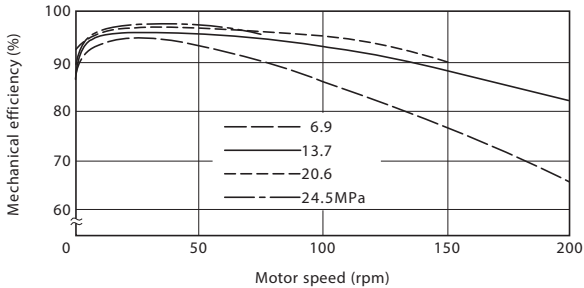

Fig. 1: Mechanical efficiency

Mechanical efficiency at various speeds is shown for 4 operating pressures.

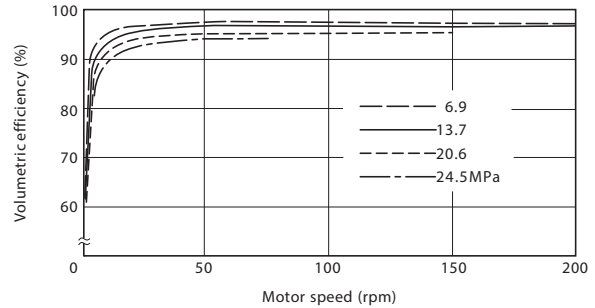

Fig. 2: Volumetric efficiency

Volumetric efficiency at various speeds is shown for 4 operating pressures.

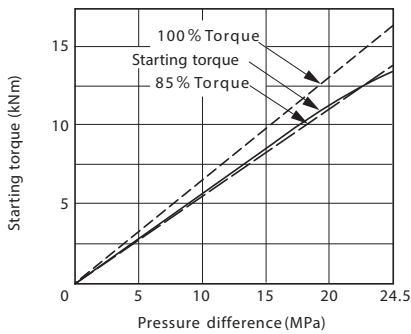

Fig. 3: Starting torque

Starting torque versus effective pressure is shown. Oil viscosity will not affect the starting torque efficiency.

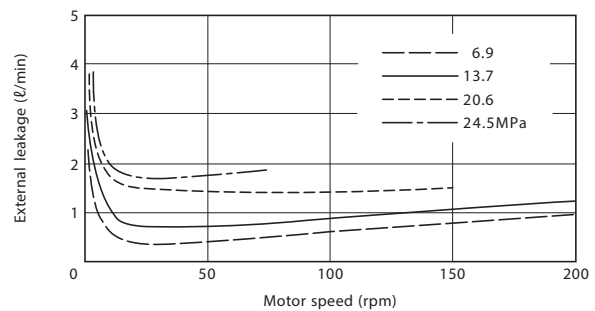

Fig. 4: External leakage

External leakage (from motor drain ports) relative to various speeds is shown for 4 operating pressures.

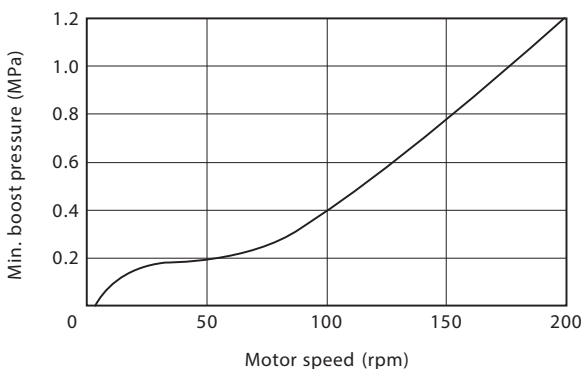

Fig. 5: Minimum boost pressure

It is important that sufficient inlet pressure is maintained, when the motor is operated as a pump or when the load overruns the motor, to prevent cavitation.

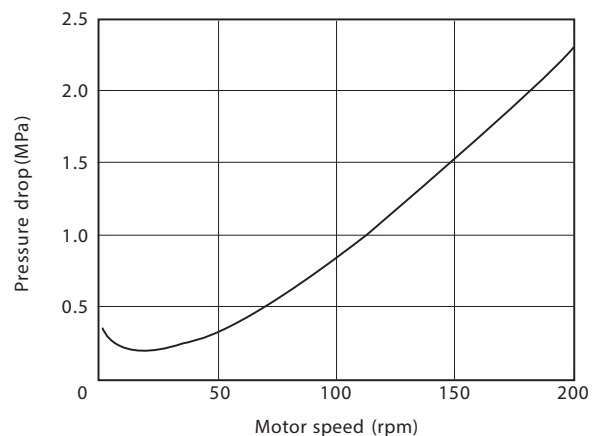

Fig. 6: Pressure drop

Pressure necessary to run motor without load is shown for various speeds.

DOWMAX ME motor

Nominal dimensions of inch size shaft and SAE ports

ME100-KE (HE)

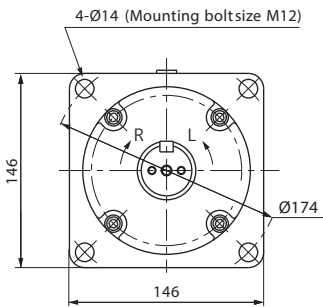

Rotation (Viewed from shaft end)
 CW : Port R pressurized
 CCW : Port L pressurized

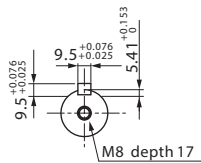

Shaft K
 Inch size
 Parallel keyed shaft



Shaft H
 Inch size spline shaft

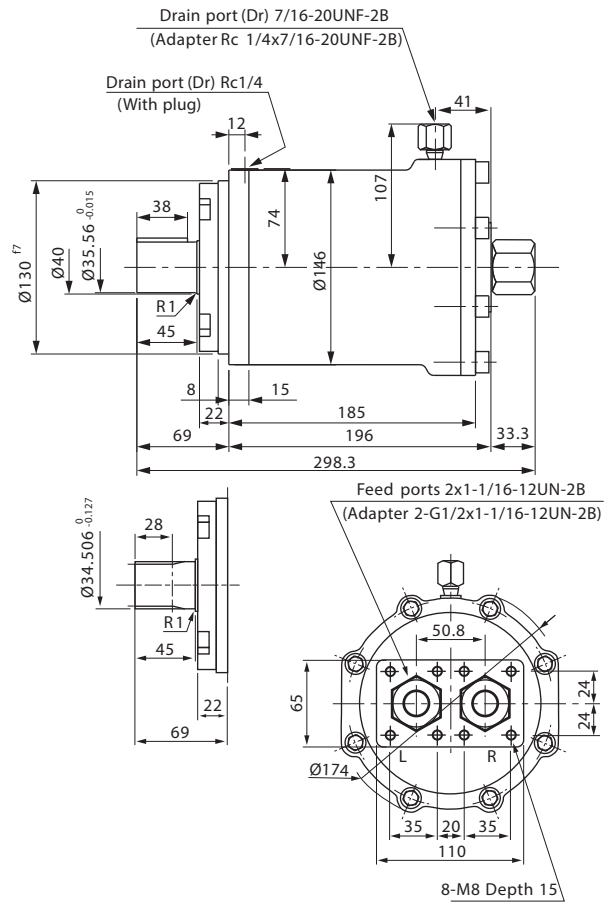

ME150-KE (HE)

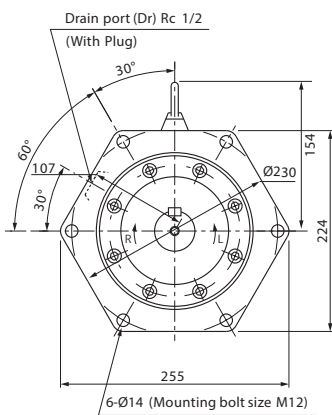

Rotation (Viewed from shaft end)
 CW : Port R pressurized
 CCW : Port L pressurized

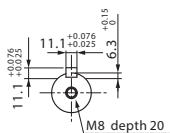

Shaft K
 Inch size
 Parallel keyed shaft

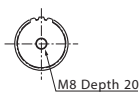

Shaft H
 Inch size spline shaft

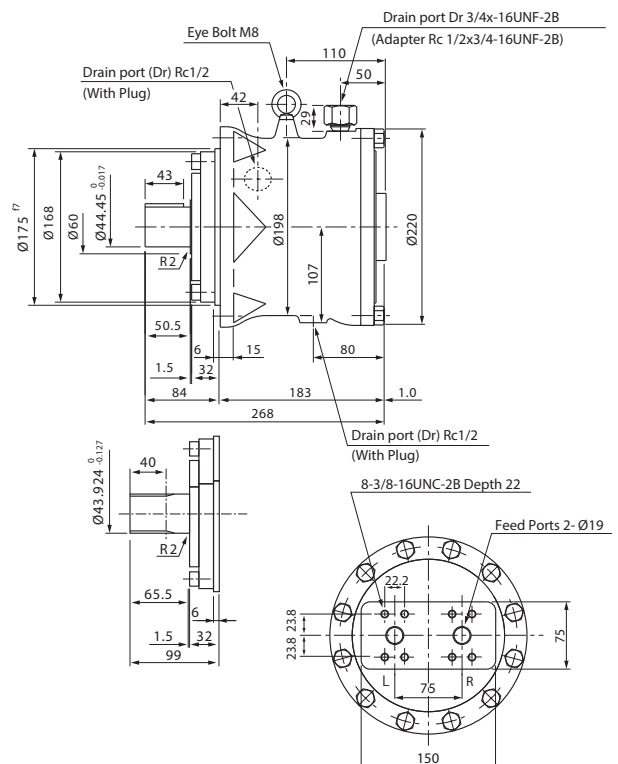

DOWMAX ME motor

ME175-KE (HE)

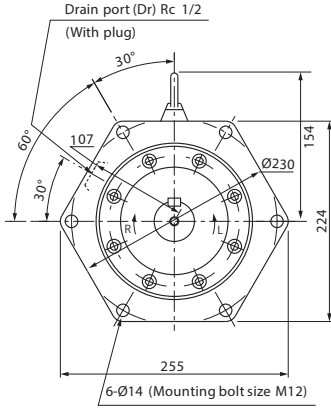

Rotation (Viewed from shaft end)
 CW : Port R pressurized
 CCW : Port L pressurized

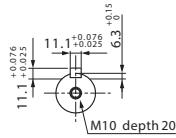

Shaft K
 Inch size
 Parallel keyed shaft

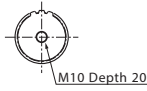

Shaft H
 Inch size spline shaft

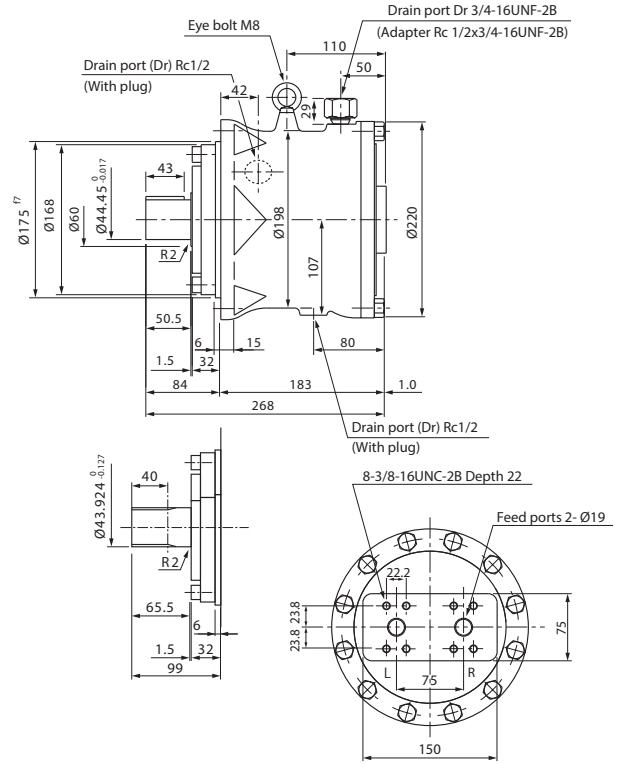

ME300KE (HE)

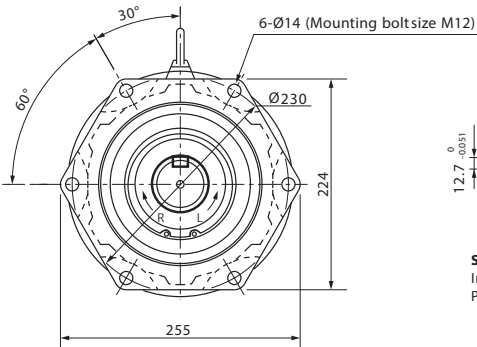

Rotation (Viewed from shaft end)
 CW : Port R pressurized
 CCW : Port L pressurized

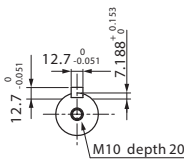

Shaft K
 Inch size
 Parallel keyed shaft

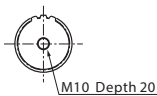

Shaft H
 Inch size spline shaft

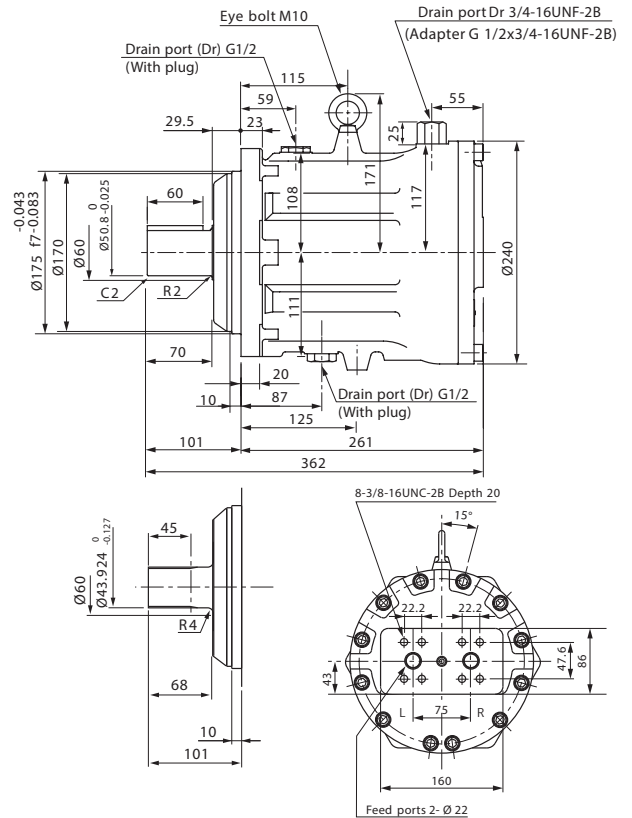

DOWMAX ME motor

Nominal dimensions of inch size shaft and SAE ports

ME350BKE (HE)

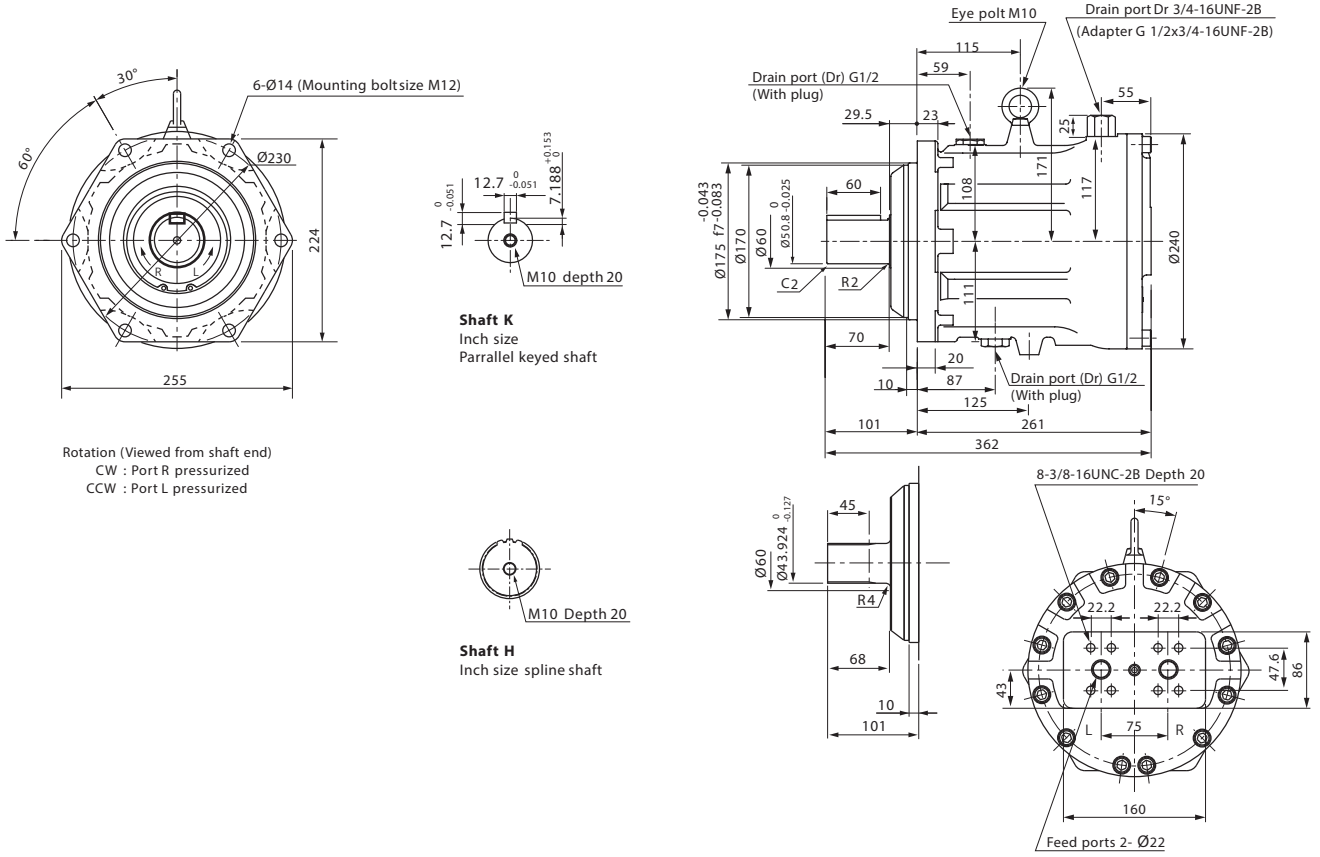

ME600BKE (HE)

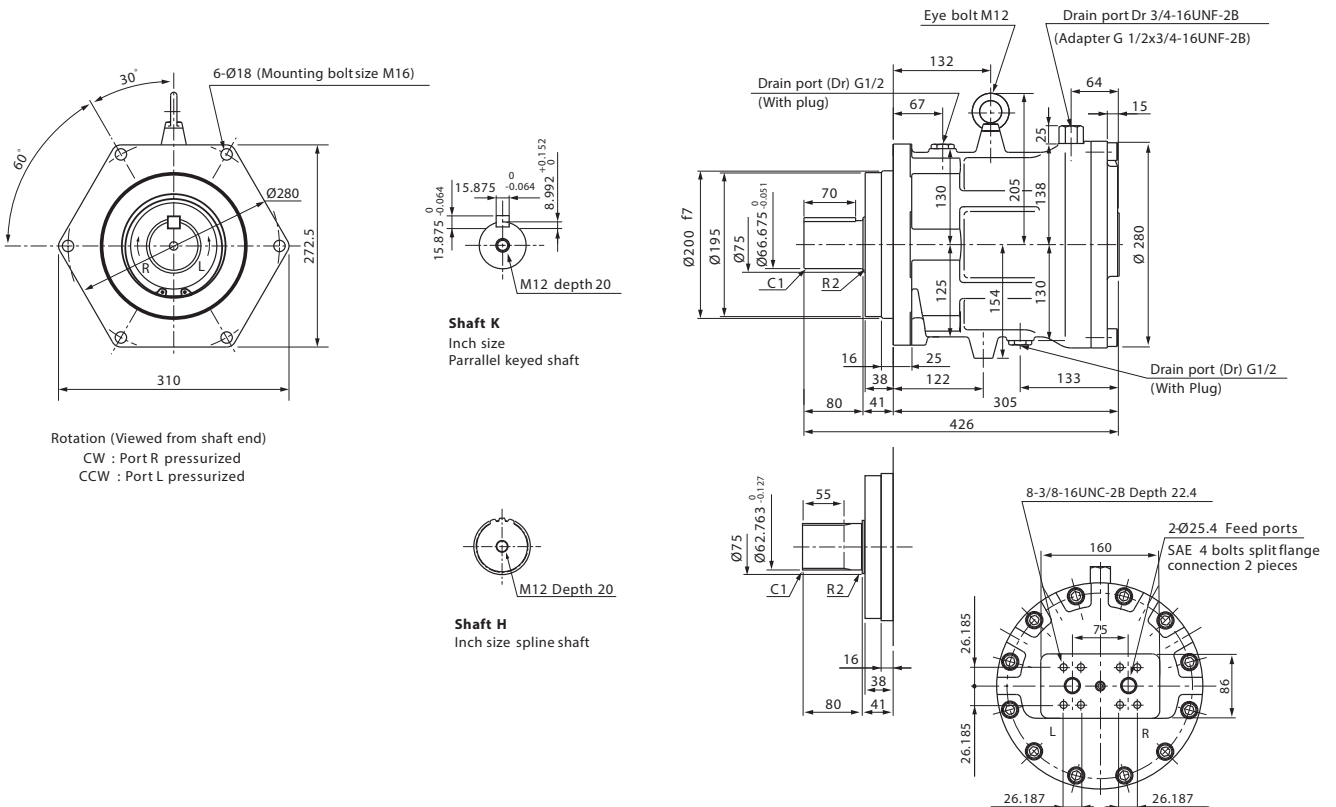

DOWMAX ME motor

ME750BKE (HE)

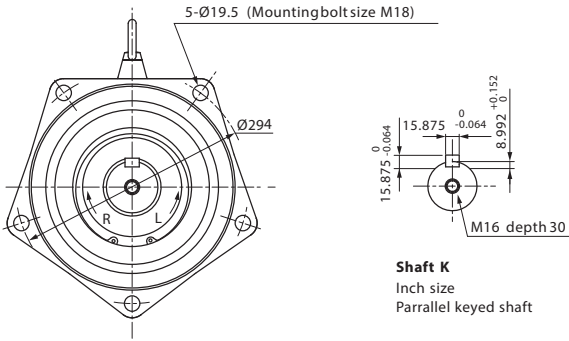

Rotation (Viewed from shaft end)
CW : Port R pressurized
CCW : Port L pressurized

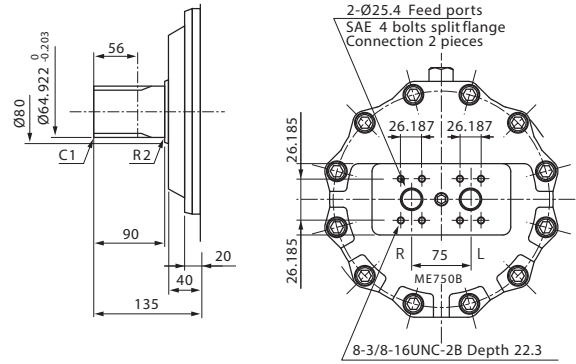
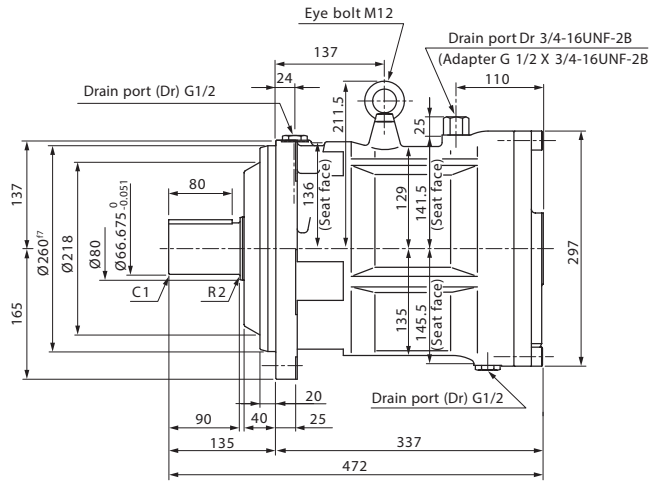
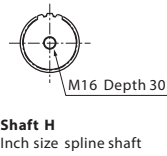

ME850BKE (HE)

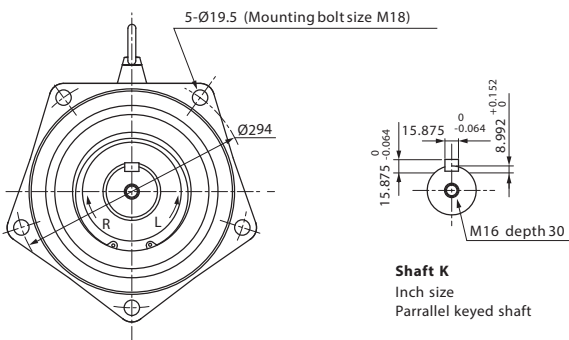

Rotation (Viewed from shaft end)
CW : Port R pressurized
CCW : Port L pressurized

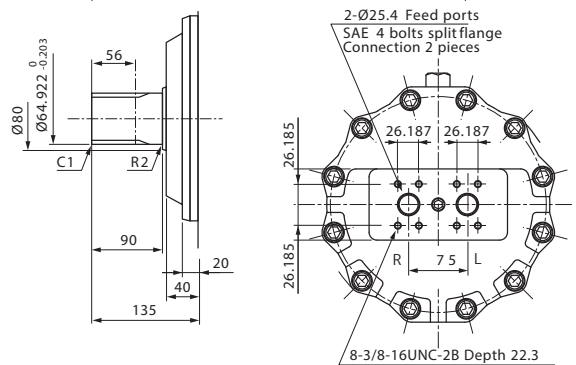
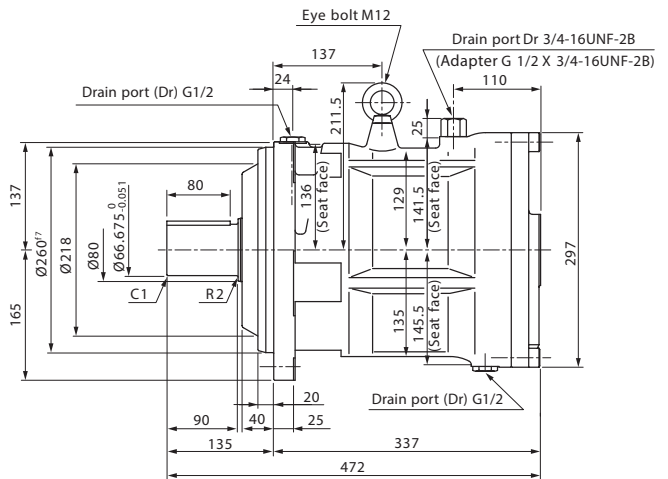
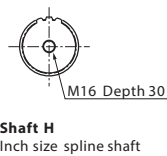

DOWMAX ME motor

Nominal dimensions of inch size shaft and SAE ports

ME1300AKE (HE)

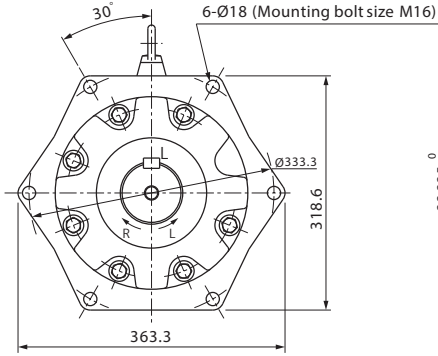

Rotation (Viewed from shaft end)
 CW : Port R pressurized
 CCW : Port L pressurized

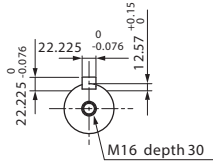

Shaft K
 Inch size
 Parallel keyed shaft

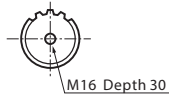

Shaft H
 Inch size spline shaft

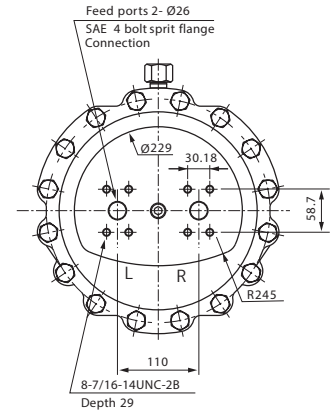
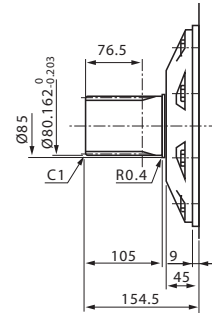
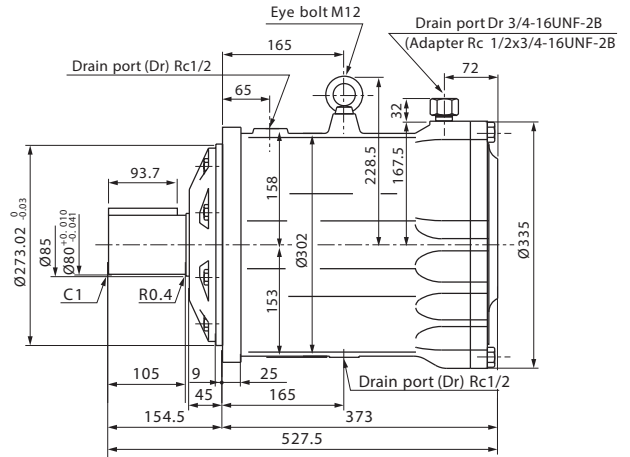

ME1900-KE (HE)

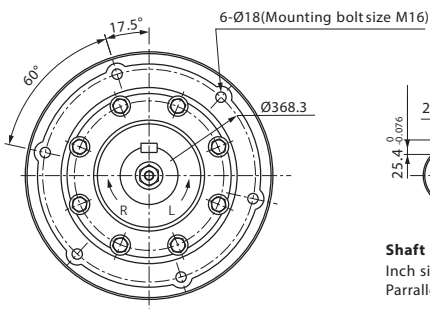

Rotation (Viewed from shaft end)
 CW : Port R pressurized
 CCW : Port L pressurized

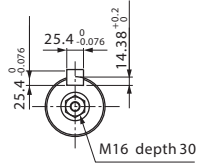

Shaft K
 Inch size
 Parallel keyed shaft



Shaft H
 Inch size spline shaft

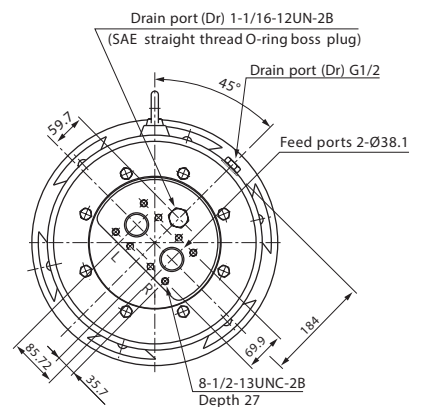
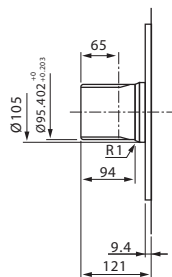
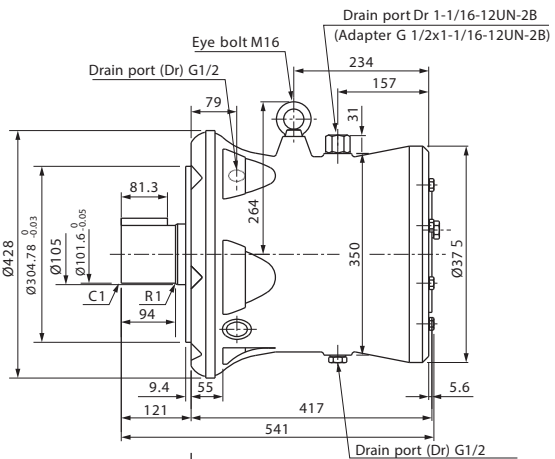

DOWMAX ME motor

ME2600-KE (HE)

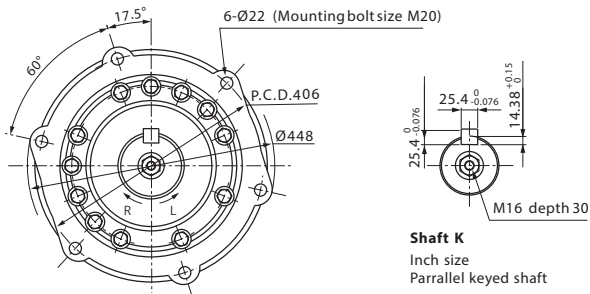

Rotation (Viewed from shaft end)
CW : Port R pressurized
CCW : Port L pressurized

Shaft K
Inch size
Parallel keyed shaft

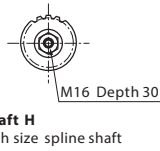

Shaft H
Inch size spline shaft

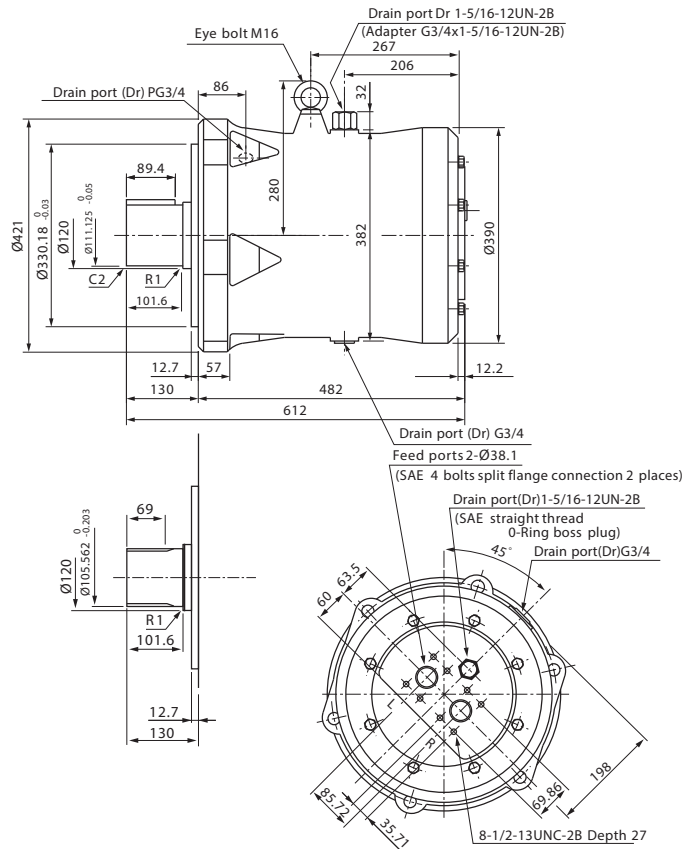

ME3100-KE (HE)

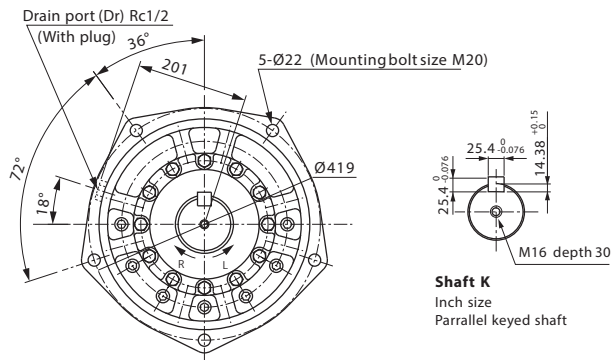

Rotation (Viewed from shaft end)
CW : Port R pressurized
CCW : Port L pressurized

Shaft K
Inch size
Parallel keyed shaft

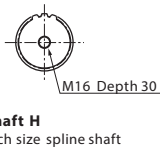

Shaft H
Inch size spline shaft

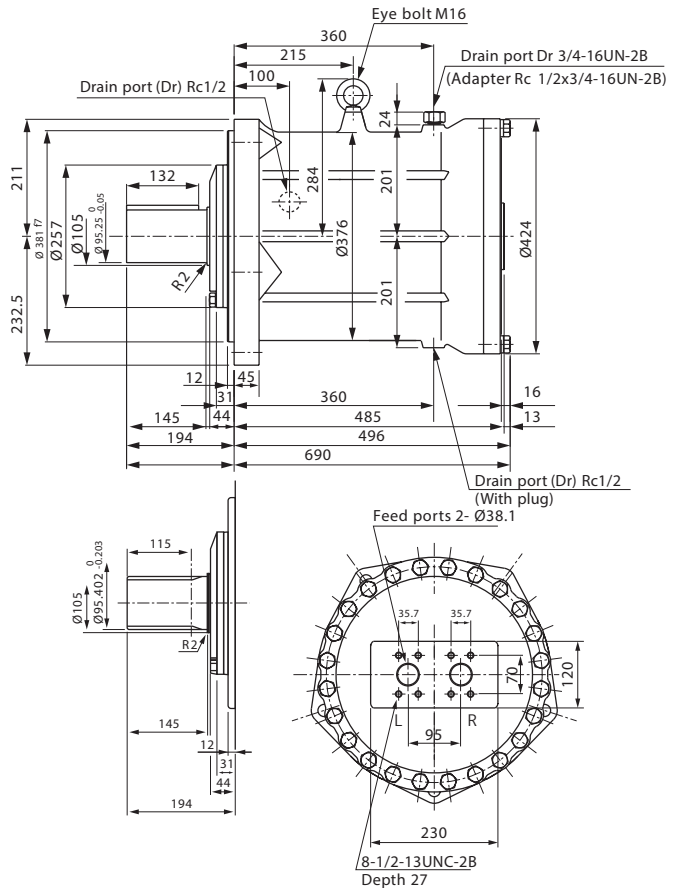

DOWMAX ME motor

Nominal dimensions of inch size shaft and SAE ports

ME4100-KE (HE)

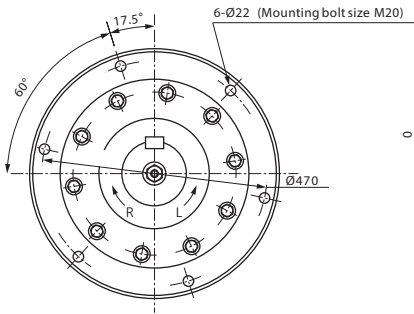

Rotation (Viewed from shaft end)
 CW : Port R pressurized
 CCW : Port L pressurized

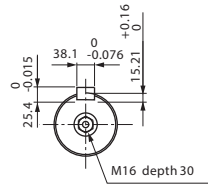

Shaft K
 Inch size
 Parallel keyed shaft

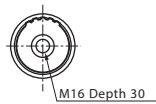

Shaft H
 Inch size spline shaft

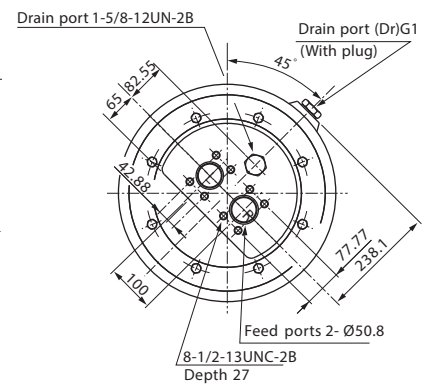
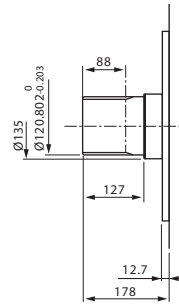
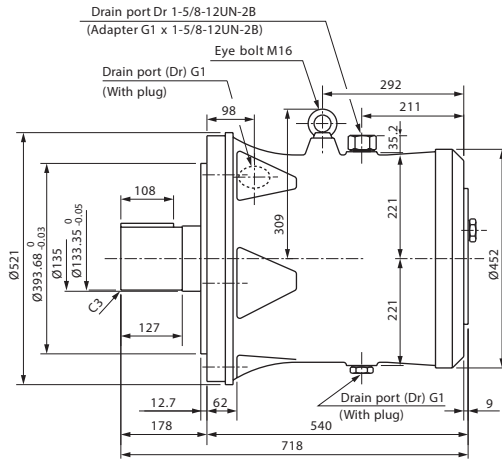

DOWMAX ME motor

Specification of spline

ME100

Type of spline : Involute : Flat root side fit
 Pressure angle 30°: Pitch 16/32 Class 1 Fit:
 To B. S. 3550 Or A. S. A. -B5-15

Shaft	No. of teeth	21
	Pitch dia.	33.338
	Base dia.	28.872
	Tooth thickness	2.416 $\begin{smallmatrix} 0 \\ -0.030 \end{smallmatrix}$
	Major dia.	34.506 $\begin{smallmatrix} 0 \\ -0.127 \end{smallmatrix}$
	Form dia.	31.648
	Minor dia.	31.052 $\begin{smallmatrix} +0.279 \\ 0 \end{smallmatrix}$
Hole	Fillet radius	0.28
	No. of teeth	21
	Pitch	16/32
	Pressure angle	30°
	Pitch dia.	33.338
	Major dia.	34.925 $\begin{smallmatrix} +0.279 \\ 0 \end{smallmatrix}$
	Minor dia.	31.750 $\begin{smallmatrix} +0.127 \\ 0 \end{smallmatrix}$
Space width	2.535 $\begin{smallmatrix} +0.03 \\ 0 \end{smallmatrix}$	

ME150 & ME175

Type of spline : Involute : Flat root side fit
 Pressure angle 30°: Pitch 12/24
 Class 1 Fit: To B. S. 3550 Or A. S. A. -B5-15

Shaft	No. of teeth	20
	Pitch dia.	42.334
	Base dia.	36.662
	Tooth thickness	3.286 $\begin{smallmatrix} -0.045 \\ -0.078 \end{smallmatrix}$
	Major dia.	43.924 $\begin{smallmatrix} 0 \\ -0.127 \end{smallmatrix}$
	Form dia.	40.114
	Minor dia.	39.692
Hole	Fillet radius	0.3556
	No. of teeth	20
	Pitch	12/24
	Pressure angle	30°
	Pitch dia.	42.3342
	Major dia.	44.450 $\begin{smallmatrix} +0.33 \\ 0 \end{smallmatrix}$
	Minor dia.	40.216 $\begin{smallmatrix} +0.12 \\ 0 \end{smallmatrix}$
Space width	3.368 $\begin{smallmatrix} +0.033 \\ 0 \end{smallmatrix}$	

ME300B & ME350B

Type of spline : Involute : Flat root side fit
 Pressure angle 30°: Pitch 12/24
 Class 1 Fit: To B. S. 3550 Or A. S. A. -B5-15

Shaft	No. of teeth	20
	Pitch dia.	42.334
	Base dia.	36.662
	Tooth thickness	3.286 $\begin{smallmatrix} -0.045 \\ -0.078 \end{smallmatrix}$
	Major dia.	43.924 $\begin{smallmatrix} 0 \\ -0.127 \end{smallmatrix}$
	Form dia.	40.114
	Minor dia.	39.692
Hole	Fillet radius	0.3556
	No. of teeth	20
	Pitch	12/24
	Pressure angle	30°
	Pitch dia.	42.3342
	Major dia.	44.450 $\begin{smallmatrix} +0.33 \\ 0 \end{smallmatrix}$
	Minor dia.	40.216 $\begin{smallmatrix} +0.12 \\ 0 \end{smallmatrix}$
Space width	3.368 $\begin{smallmatrix} +0.033 \\ 0 \end{smallmatrix}$	

ME600B

Type of spline : Involute : Flat root side fit
 Pressure angle 30°: Pitch 8/16
 Class 1 Fit: To B. S. 3550 Or A. S. A. -B5-15

Shaft	No. of teeth	19
	Pitch dia.	60.325
	Base dia.	52.243
	Tooth thickness	4.897 $\begin{smallmatrix} 0 \\ -0.035 \end{smallmatrix}$
	Major dia.	62.763 $\begin{smallmatrix} 0 \\ -0.127 \end{smallmatrix}$
	Form dia.	57.028
	Minor dia.	56.413 $\begin{smallmatrix} 0 \\ -0.457 \end{smallmatrix}$
Hole	Fillet radius	0.991
	No. of teeth	19
	Pitch	8/16
	Pressure angle	30°
	Pitch dia.	60.325
	Major dia.	63.50 $\begin{smallmatrix} +0.457 \\ 0 \end{smallmatrix}$
	Minor dia.	57.15 $\begin{smallmatrix} +0.127 \\ 0 \end{smallmatrix}$
Space width	5.034 $\begin{smallmatrix} +0.036 \\ 0 \end{smallmatrix}$	

ME750B & ME850B

Type of spline : Involute : Flat root side fit
 Pressure angle 30°: Pitch 5/10
 Class 1 Fit: To B. S. 3550 Or A. S. A. -B5-15

Shaft	No. of teeth	12
	Pitch dia.	60.96
	Base dia.	52.79
	Tooth thickness	7.935 $\begin{smallmatrix} -0.051 \\ -0.089 \end{smallmatrix}$
	Major dia.	64.922 $\begin{smallmatrix} 0 \\ -0.203 \end{smallmatrix}$
	Form dia.	56.055
	Minor dia.	54.762 $\begin{smallmatrix} 0 \\ -0.635 \end{smallmatrix}$
Hole	Fillet radius	0.9906
	No. of teeth	12
	Pitch	5/10
	Pressure angle	30°
	Pitch dia.	60.96
	Major dia.	66.04 $\begin{smallmatrix} +0.635 \\ 0 \end{smallmatrix}$
	Minor dia.	56.177 $\begin{smallmatrix} +0.203 \\ 0 \end{smallmatrix}$
Space width	8.034 $\begin{smallmatrix} +0.038 \\ 0 \end{smallmatrix}$	

ME1300A

Type of spline : Involute : Flat root side fit
 Pressure angle 30°: Pitch 5/10
 Class 1 Fit: To B. S. 3550 Or A. S. A. -B5-15

Shaft	No. of teeth	15
	Pitch dia.	76.2
	Base dia.	65.992
	Tooth thickness	7.879 $\begin{smallmatrix} 0 \\ -0.038 \end{smallmatrix}$
	Major dia.	80.162 $\begin{smallmatrix} 0 \\ -0.203 \end{smallmatrix}$
	Form dia.	71.00
	Minor dia.	70.000 $\begin{smallmatrix} 0 \\ -0.633 \end{smallmatrix}$
Hole	Fillet radius	0.889
	No. of teeth	15
	Pitch	5/10
	Pressure angle	30°
	Pitch dia.	76.2
	Major dia.	81.28 $\begin{smallmatrix} +0.635 \\ 0 \end{smallmatrix}$
	Minor dia.	71.252 $\begin{smallmatrix} +0.203 \\ 0 \end{smallmatrix}$
Space width	8.037 $\begin{smallmatrix} +0.038 \\ 0 \end{smallmatrix}$	

DOWMAX ME motor

ME1900

Type of spline : Involute : Flat root side fit
 Pressure angle 30°: Pitch 5/10
 Class 1 Fit: To B. S. 3550 Or A. S. A. -B5-15

Shaft	No. of teeth	18
	Pitch dia.	91.44
	Base dia.	79.19
	Tooth thickness	7.932/7.836
	Major dia.	95.402 ⁰ _{-0.203}
	Form dia.	86.215
	Minor dia.	85.242 ⁰ _{-0.635}
	Fillet radius	0.813
Hole	No. of teeth	18
	Pitch	5/10
	Pressure angle	30°
	Pitch dia.	91.44
	Major dia.	96.52 ^{+0.635} ₀
	Minor dia.	86.398 ^{+0.203} ₀
	Space width	8.037 ^{+0.04} ₀

ME2600

Type of spline : Involute : Flat root side fit
 Pressure angle 30°: Pitch 5/10
 Class 1 Fit: To B. S. 3550 Or A. S. A. -B5-15

Shaft	No. of teeth	20
	Pitch dia.	101.6
	Base dia.	87.988
	Tooth thickness	7.932 ^{-0.058} _{-0.099}
	Major dia.	105.562 ⁰ _{-0.203}
	Form dia.	96.317
	Minor dia.	95.402 ⁻⁰ _{-0.635}
	Fillet radius	0.7874
Hole	No. of teeth	20
	Pitch	5/10
	Pressure angle	30°
	Pitch dia.	101.6
	Major dia.	106.68 ^{+0.63} ₀
	Minor dia.	96.52 ^{+0.20} ₀
	Space width	8.039 ^{+0.041} ₀

ME3100

Type of spline : Involute : Flat root side fit
 Pressure angle 30°: Pitch 5/10
 Class 1 Fit: To B. S. 3550 Or A. S. A. -B5-15

Shaft	No. of teeth	18
	Pitch dia.	91.440
	Base dia.	79.190
	Tooth thickness	7.932 ^{-0.055} _{-0.099}
	Major dia.	95.402 ⁻⁰ _{-0.203}
	Form dia.	86.215
	Minor dia.	85.242 ⁻⁰ _{-0.635}
	Fillet radius	0.813
Hole	No. of teeth	18
	Pitch	5/10
	Pressure angle	30°
	Pitch dia.	91.44
	Major dia.	96.52 ^{+0.635} ₀
	Minor dia.	86.398 ^{+0.203} ₀
	Space width	8.042 ^{+0.035} ₀

ME4100

Type of spline : Involute : Flat root side fit
 Pressure angle 30°: Pitch 5/10
 Class 1 Fit: To B. S. 3550 Or A. S. A. -B5-15

Shaft	No. of teeth	23
	Pitch dia.	116.84
	Base dia.	101.186
	Tooth thickness	7.932/7.831
	Major dia.	120.802 ⁻⁰ _{-0.203}
	Form dia.	115.526
	Minor dia.	110.642 ⁻⁰ _{-0.635}
	Fillet radius	0.762
Hole	No. of teeth	23
	Pitch	5/10
	Pressure angle	30°
	Pitch dia.	116.84
	Major dia.	121.92 ^{+0.635} ₀
	Minor dia.	111.76 ^{+0.203} ₀
	Space width	8.042 ^{+0.040} ₀

DOWMAX ME motor

Bearing life and allowable radial load for shaft

ME100

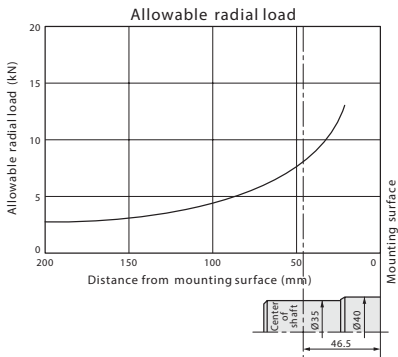

Fig. 1

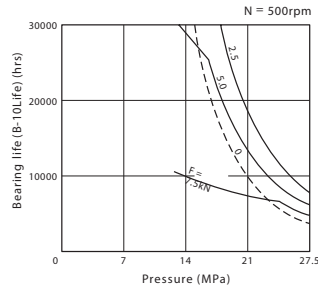
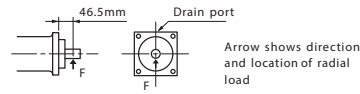

Fig. 2

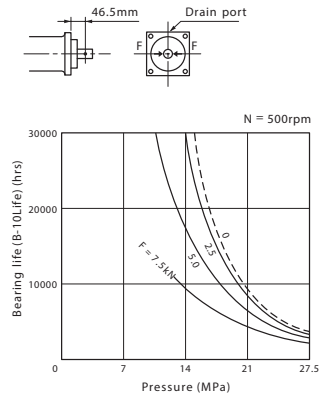

Fig. 3

ME150

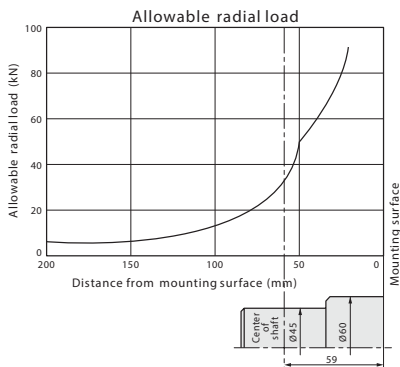

Fig. 1

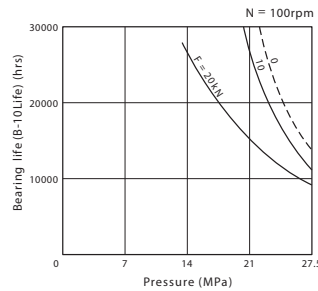
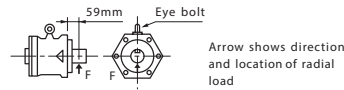

Fig. 2

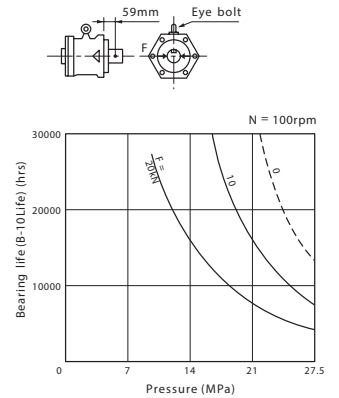

Fig. 3

ME175

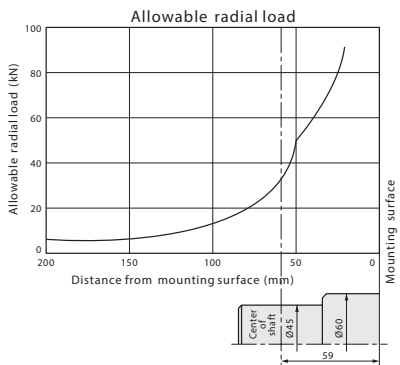

Fig. 1

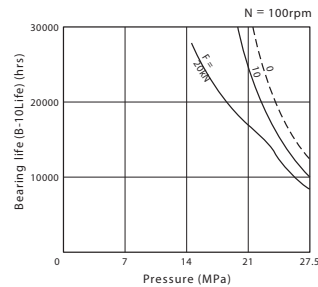
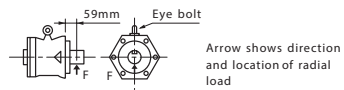

Fig. 2

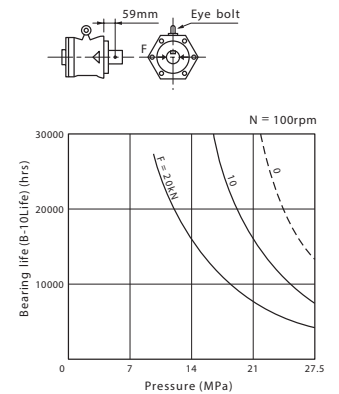

Fig. 3

DOWMAX ME motor

ME300B

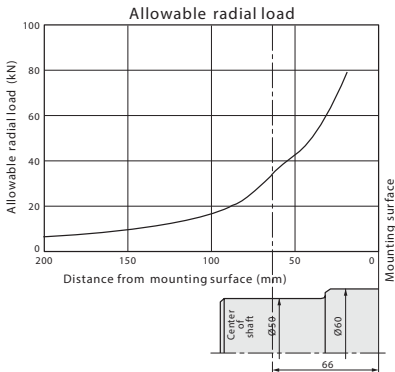

Fig. 1

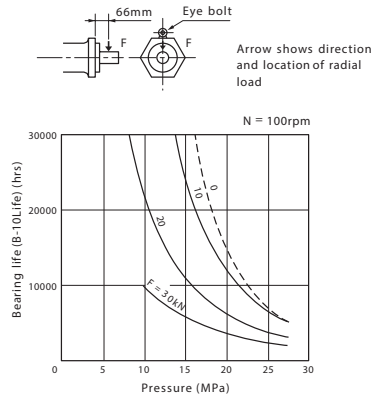

Fig. 2

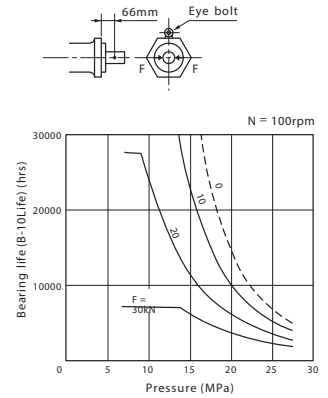

Fig. 3

ME350B

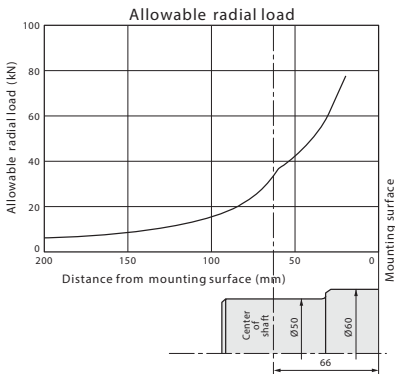

Fig. 1

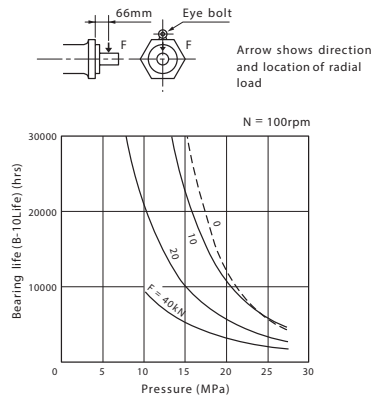

Fig. 2

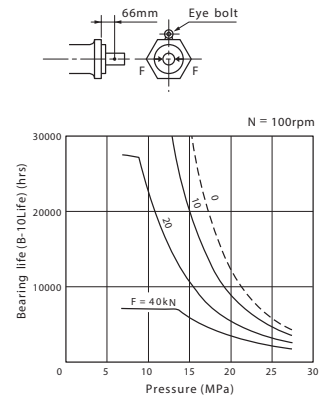

Fig. 3

ME600B

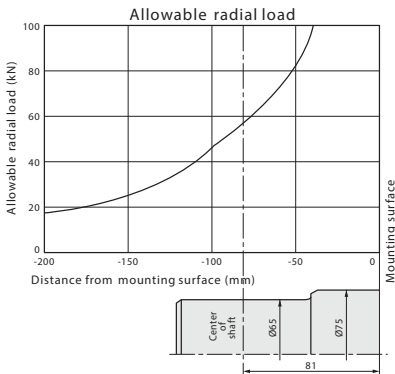

Fig. 1

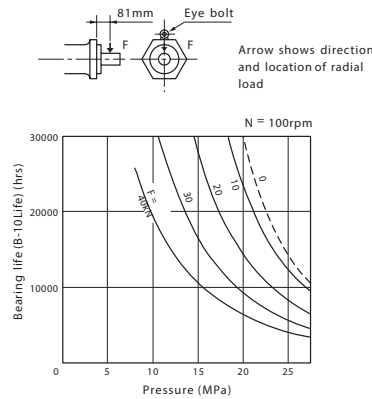

Fig. 2

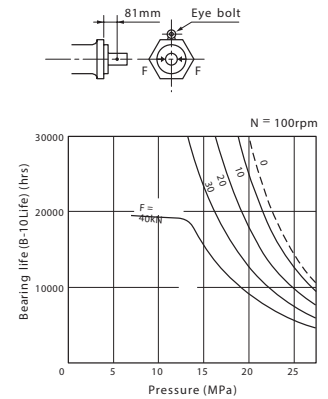

Fig. 3

- Note:** 1. If motors are operated within the proper ratings and conditions, the operational life is determined by the bearing life.
 2. In order to maintain the maximum bearing life, when a radial load is imposed on the output shaft the motor should be installed as illustrated in Fig. 2 or Fig. 3.
 For a uni-directional application, motor should be installed so that side load acts as shown in Fig. 2.
 For a bi-directional application, a radial load for each rotational direction being applied, the motor should be installed so that side loads act as shown in Fig. 3.
 3. The graphs shown are the bearing life (B-10 Life) at 100 rpm shaft speed (500 rpm only for ME100) for various pressures and radial loads. When the shaft speed differs from 100 rpm (500 rpm only for ME100) the bearing life can be obtained by the following formula:

$$\text{B-10 Life} = (\text{Bearing Life obtainable in the graph}) \times \frac{100 \text{ (500 for ME100)}}{\text{Actual Shaft Speed, rpm}}$$

In case where the side load acts at a different location to the midpoint of the shaft projection please refer to us.

- Applications with axial thrust loads should be referred to us.
- When motor is used in meter-out circuit, pressure in Fig. 2 & 3 shaft be a sum of motor inlet and outlet pressure.
- Bearing life varies due to kind of fluid. Bearing life should be decided by multiplying by the factor as shown in table:

Fluid type	life factor
Mineral-based fluid	1.0
Phosphate-ester fluid	1.0
Water-glycol w/o forced lubrication	0.05~0.10
Water-glycol w/ forced lubrication	0.6

DOWMAX ME motor

Bearing life and allowable radial load for shaft

ME750B

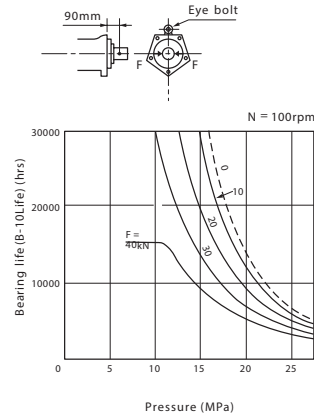
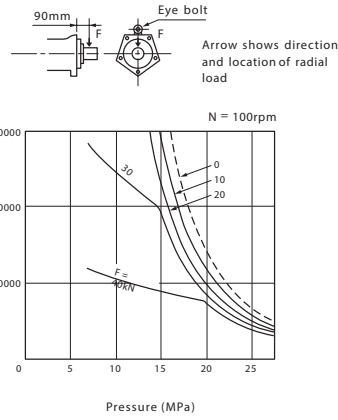
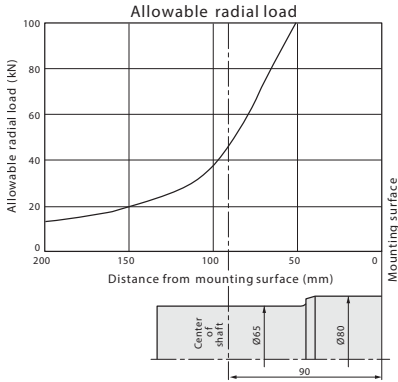

ME850B

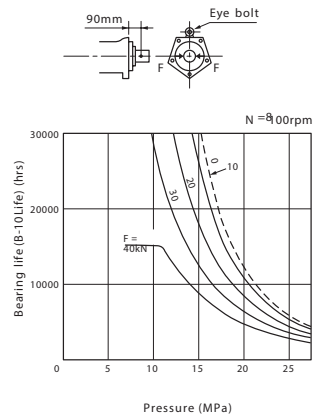
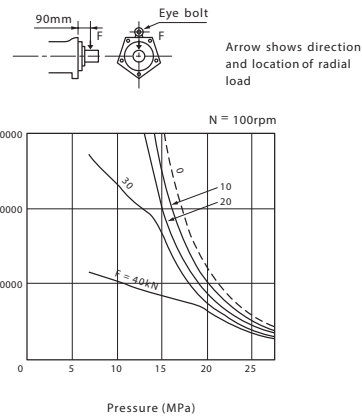
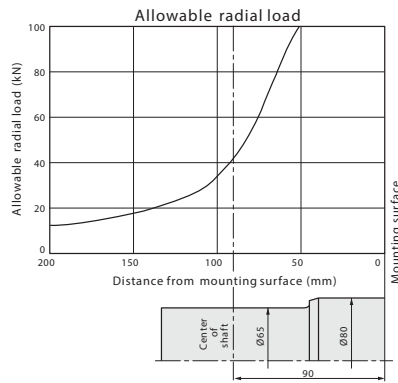

ME1300A

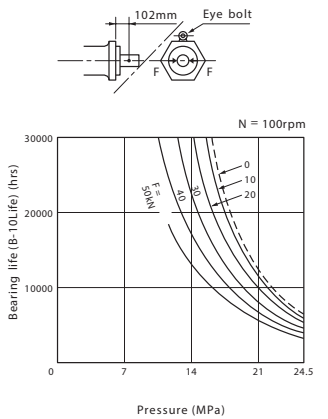
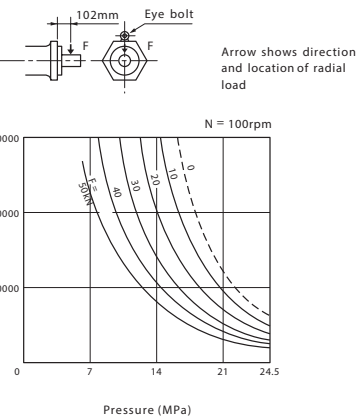
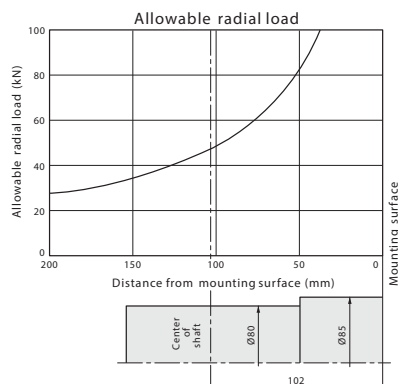

DOWMAX ME motor

ME1900

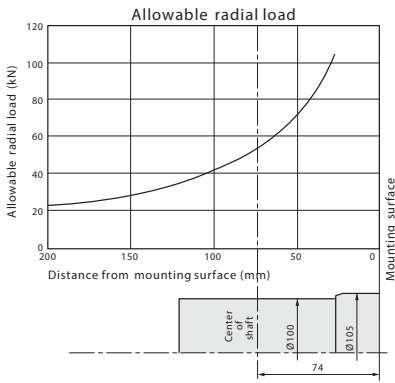

Fig. 1

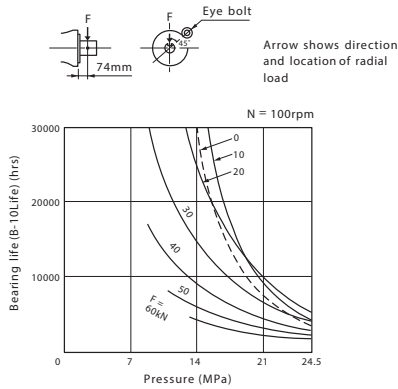

Fig. 2

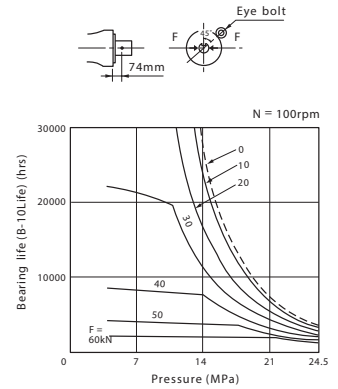

Fig. 3

ME2600

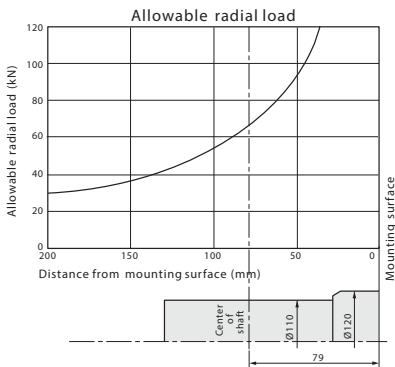

Fig. 1

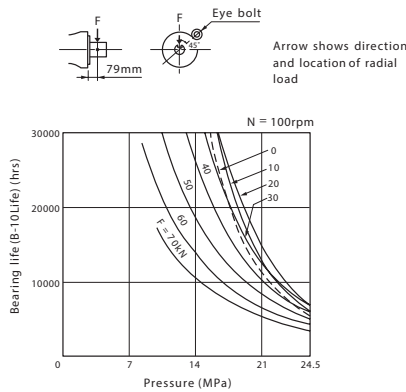

Fig. 2

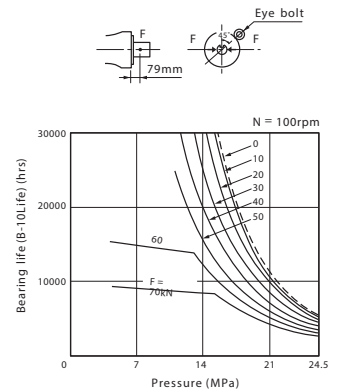

Fig. 3

ME3100

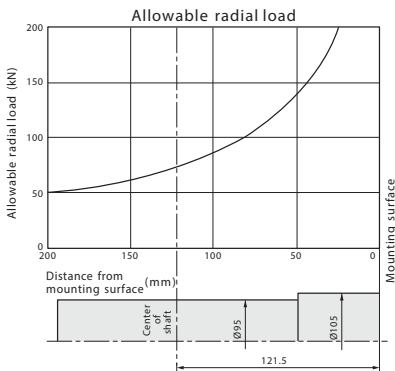

Fig. 1

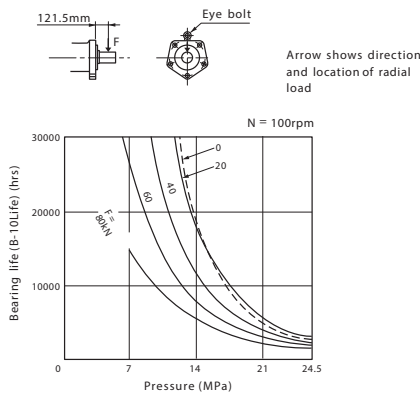

Fig. 2

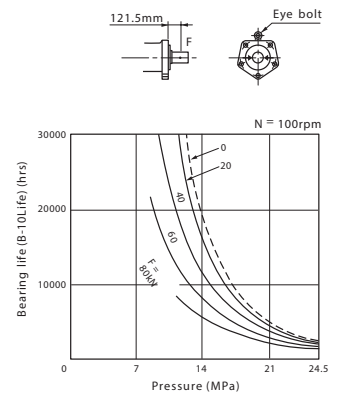

Fig. 3

- Note:**
- If motors are operated within the proper ratings and conditions, the operational life is determined by the Bearing Life.
 - In order to maintain the maximum bearing life, when a radial load is imposed on the output shaft the motor should be installed as illustrated in Fig. 2 or Fig. 3; For a uni-directional application, motor should be installed so that side load acts as shown in Fig. 2. For a bi-directional application, a radial load for each rotational direction being applied, the motor should be installed so that side loads act as shown in Fig. 3.
 - The graphs shown are the bearing life (B-10 Life) at 100 rpm shaft speed (500 rpm only for ME100) for various pressures and radial loads. When the shaft speed differs from 100 rpm (500 rpm only for ME100) the bearing life can be obtained by the following formula:

$$\text{B-10 Life} = (\text{Bearing Life obtainable in the graph}) \times \frac{100 \text{ (500 for ME100)}}{\text{Actual shaft speed, rpm}}$$

In case where the side load acts at a different location to the midpoint of the shaft projection please refer to us.

- Applications with axial thrust loads should be referred to us.
- When motor is used in meter-out circuit, pressure in Fig. 2 & 3 shaft be a sum of motor inlet and outlet pressure.
- Bearing life varies due to kind of fluid. Bearing life should be decided by multiplying by the factor as shown in table:

Fluid type	life factor
Mineral-based fluid	1.0
Phosphate-ester fluid	1.0
Water-glycol w/o forced lubrication	0.05~0.10
Water-glycol w/ forced lubrication	0.6

DOWMAX ME motor

Bearing life and allowable radial load for shaft

ME4100

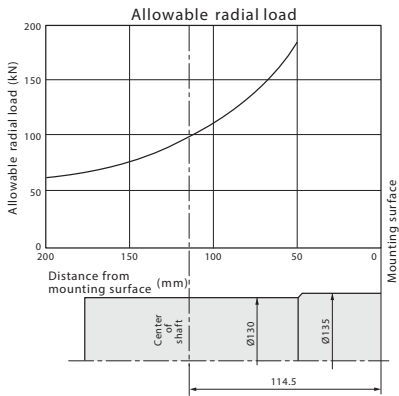

Fig. 1

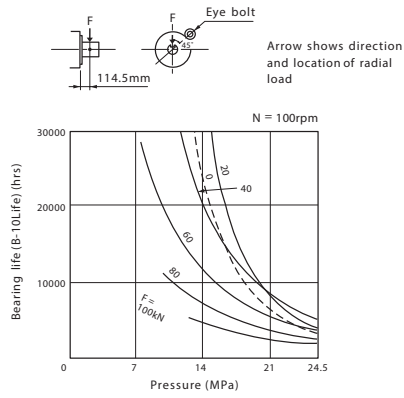

Fig. 2

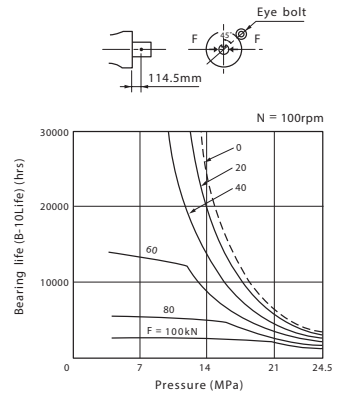
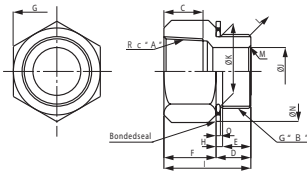

Fig. 3

DOWMAX ME motor

Accessory parts dimensions

Adapter



Part No.	A	B	C	D	E	F	G	H	I	J	K	L	M	N	O	Part No. of bonded seal
T21154-1-A	Rc1/2	G1/2	15	14	11	22	27	3	36	10	18	C1	C1	30	23	DW0036A-004
T21154-2-A	3/4	3/4	17	16	12	25	36	3	41	16	23.5	C1	C1	35	23	DW0036A-006
T21154-3-A	1	1	19	18	15	27	41	3	45	21.5	29.5	C1	C1	42	3.2	DW0036A-008
T21154-4-A	1-1/4	1-1/4	22	21	18	30	50	3	51	27.5	38	C1.5	C2	54	2.3	DW0036A-010
T21154-5-A	1-1/2	1-1/2	22	21	18	30	60	3	51	33	44	C1.5	C2	65	3.2	DW0036A-012
T21154-6-A	2	2	26	26	22	36	70	4	62	44	56	C1.5	C2	72	3.2	DW0036A-016

Note: The Part No. with suffix “-A” indicates that adapter is supplied with bonded seal.

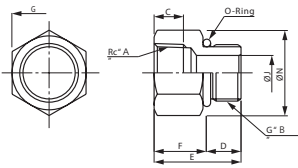

Part No.	A	B	C	D	E	F	G	J	N	Mass (g)	O-Ring
DW0331A-002	Rc1/4	G1/4	11	12	29	17	19	5	19	35	1BP11
DW0331A-003	3/8	3/8	12	12	31	19	22	8	22	55	1BP14
DW0331A-004	1/2	1/2	15	16	38	22	27	10	27	90	1BP18
DW0331A-006	3/4	3/4	17	17	42	25	36	16	36	180	1BP22.4
DW0331A-008	1	1	19	21	48	27	41	22	41	230	1BP29
DW0331A-010	1-1/4	1-1/4	22	21	51	30	50	27	50	380	1BP38
DW0331A-012	1-1/2	1-1/2	22	21	51	30	60	33	60	490	1BP44
DW0331A-016	2	2	26	25	61	36	70	44	70	780	1BP56

Note: The O-ring and the fitting are JIS standard product. It is possible to use a marketing product, too.

Straight flange

(Socket welding connection)

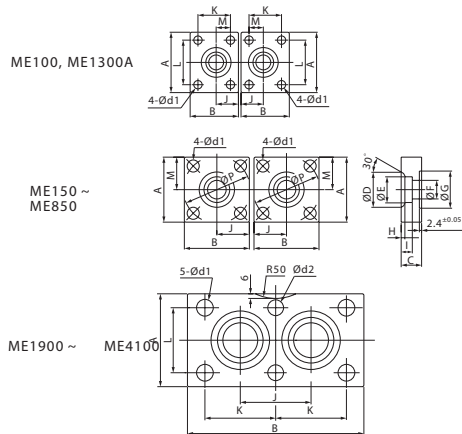

Dowmax Model	ME100	ME150 ME175 ME300B ME350B	ME600B ME750B ME850B	ME1300A	ME1900	ME2600	ME3100	ME4100
Part No.	DM0277A-A	DA0751A-A	DB0467A-A	DE0512A-A	T10838-A	T10841-A	DK0026B-A	T10845-A
A	65	70	70	100	84	100	120	114
B	52	70	70	100	165	190	230	230
C	22	22	25	36	40	40	40	40
D	32	38	45	63	63	63	63	75
E	22.2	27.7	34.5	49.1	49.1	49.1	49.3	61.1
F	16	20	25	37.5	37.5	37.5	37.5	47.5
G	30	40	45	55	60	65	60	80
H	3.5	4	4	7	7	7	7	7
I	11	12	14	18	18.5	18	18	20
J	24	35	35	50	66.5	76.2	95	94
K	35	—	—	70	66.5	76.2	95	94
L	48	—	—	70	60	70	85	82.5
M	15.4	35	35	35	—	—	—	—
P	—	72	72	—	—	—	—	—
d1	9	13	13	18	14	18	18	18
d2	—	—	—	—	14	17	18	18
O-Ring	1BG25	1BG35	1BG40	1BG50	1BG55	1BG60	1BG55	1BG75
Hex. socket headbolt	8-M8X35	8-M12X40	8-M12X45	8-M16X60	6-M12X60	6-M16X60	6-M16X60	6-M16X60

Note: The cut shown with R50 is only for ME2600.

Elbow flange

(Socket welding connection)

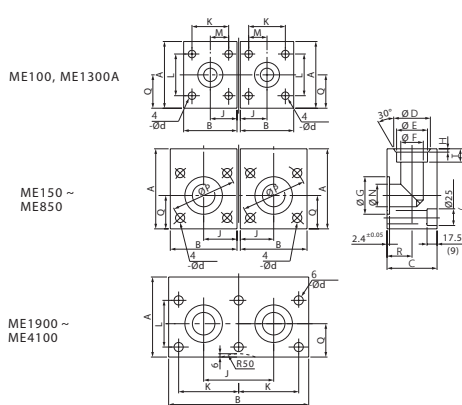

Dowmax Model	ME100	ME150 ME175 ME300B ME350B	ME600B ME750B ME850B	ME1300A	ME1900	ME2600	ME3100	ME4100
Part No.	DM0278A-A	DA0683B-A	DB0369A-A	DE0513A-A	T22130-A	T22131-A	DK0037B-A	T22132-A
A	75	80	85	110	106	114	125	132
B	52	73	70	100	165	190	230	230
C	38	45	60	71	71	71	90	85
D	32	38	45	63	63	63	56	75
E	22.2	27.7	34.5	49.1	49.1	49.1	43.2	61.1
F	16	20	25	37.5	37.5	37.5	31.5	47.5
G	30	40	45	55	60	65	60	80
H	3.5	4	4	7	7	7	7	7
I	11	12	14	18	18	18	18	20
J	24	36.5	35	50	66.5	76.2	95	94
K	35	—	—	70	66.5	76.2	95	94
L	48	—	—	70	60	70	85	82.5
M	15.4	—	—	35	—	—	—	—
N	16	20	25	37.5	37.5	37.5	37.5	47.5
P	—	72	72	—	—	—	—	—
Q	33	37.5	37.5	50	42	50	60	57
R	20	23	35	35.5	35.5	35.5	52.5	42.5
d	9	13	13	18	14	17	18	18
O-Ring	1BG25	1BG35	1BG40	1BG50	1BG55	1BG60	1BG55	1BG75
Hex. socket headbolt (With spring washer)	—	—	8-M12x80	8-M16x95	6-M12x90	6-M16x90	—	6-M16x105
Hex. socket headbolt	8-M8x40	8-M12x60	—	—	—	—	6-M16x95	—

Note: 1. The spot-facing for hex. socket head bolt is only for ME100 & ME3100. () dimensions are for ME100.
2. The cut shown with R50 is only for ME2600.

DOWMAX ME motor

Straight flange

(Thread connection)

ME100, ME1300A

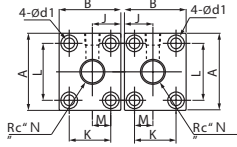

ME150 ~ ME850

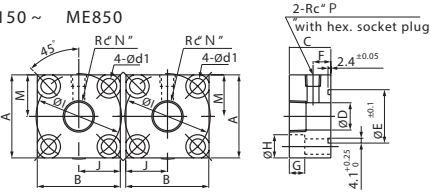

ME1900 ~ ME4100

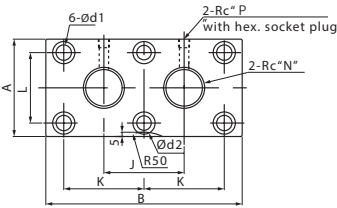

Note: The cut shown with R50 is only for ME2600.

Dowmax Model	ME100	ME150 ME175 ME300B ME350B	ME600B ME750B ME850B	ME1300A	ME1900	ME2600	ME3100	ME4100
Part No.	DM0250A-A	DA0724A-A	DB0401A-A	DE0489A-A	DG0191A-A	DH0148B-A	DK0141A-A	DJ0166B-A
A	65	70	70	100	84	100	120	114
B	52	70	70	100	165	190	230	230
C	20	35	35	40	35	40	40	40
D	18	23.5	29.5	38	44	44	44	44
E	30	45	45	55	60	65	60	80
F	10	15	15	15	15	15	15	20
G	9	13	13	17	13	17	17	18
H	14	20	20	26	20	26	26	26
I	—	72	72	—	—	—	—	—
J	24	35	35	50	66.5	76.2	95	94
K	35	—	—	70	66.5	76.2	95	94
L	48	—	—	70	60	70	85	82.5
M	15.4	35	35	35	—	—	—	—
N	Rc1/2	Rc3/4	Rc1	Rc1-1/4	Rc1-1/2	Rc1-1/2	Rc1-1/2	Rc1-1/2
P	Rc1/4	Rc1/4	Rc1/4	Rc1/4	Rc1/4	Rc1/4	Rc1/4	Rc1/4
d1	9	13	13	18	14	18	18	18
d2	—	—	—	—	14	17	18	18
O-Ring	1BG25	1BG40	1BG40	1BG50	1BG55	1BG60	1BG55	1BG75
Hex. socket head bolt	8-M8×20	8-M12×40	8-M12×40	8-M16×45	6-M12×40	6-M16×45	6-M16×45	6-M16×45

Elbow flange

(Thread connection)

ME100, ME1300A

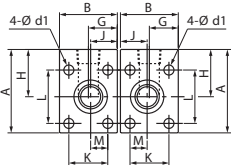

ME150 ~ ME850

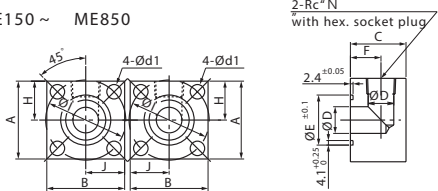

ME1900 ~ ME4100

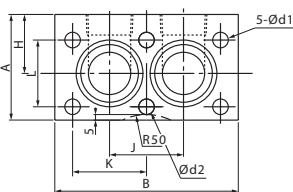

Note: The cut shown with R50 is only for ME2600.

Dowmax Model	ME100	ME150 ME175 ME300B ME350B	ME600B ME750B ME850B	ME1300A	ME1900	ME2600	ME3100	ME4100
Part No.	DM0282A-A	DA0795A-A	DB0468A-A	DE0517A-A	DG0211A-A	DH0152B-A	DK0142A-A	DJ0170A-A
A	75	70	85	110	97	110	120	117
B	52	70	70	100	165	190	230	230
C	40	50	55	65	70	70	70	70
D	18	23.5	29.5	38	44	44	44	44
E	30	45	45	55	60	65	60	80
F	23	27.5	30	36	37.5	37.5	37.5	37.5
G	26	—	—	—	—	—	—	—
H	42.5	35	50	60	55	60	60	60
I	—	72	72	—	—	—	—	—
J	24	35	35	50	66.5	76.2	95	94
K	35	—	—	70	66.5	76.2	95	94
L	48	—	—	70	60	70	85	82.5
M	15.4	—	—	—	—	—	—	—
N	Rc1/2	Rc3/4	Rc1	Rc1-1/4	Rc1-1/2	Rc1-1/2	Rc1-1/2	Rc1-1/2
d1	9	13	13	18	14	18	18	18
d2	—	—	—	—	14	17	18	18
O-Ring	1BG25	1BG40	1BG40	1BG50	1BG55	1BG60	1BG55	1BG75
Hex. socket head bolt	8-M8×50	8-M12×65	8-M12×70	8-M16×85	6-M12×80	6-M16×85	6-M16×85	6-M16×85

DOWMAX ME motor

DOWMAX motor standardizes for special function

* The following motors with special functions are available.
Select an appropriate motor that best suits your requirements.

1. DOWMAX motors with rotation detecting shaft



- These motors are for speed control use on injection molding machines, steel rolling mills, winches, etc. In these applications, they sense rotary motions and detect rotational speed for control.
- Each DOWMAX motor in the ME Series can be supplied with a rotation detecting shaft.
- Refer to drawing; DZ3503B.

2. DOWMAX motors for Water-Glycol Hydraulic fluid use (with flushing circuit)

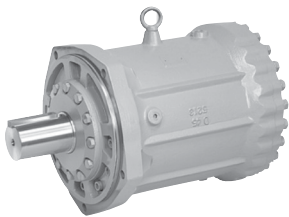

- Water-glycol fluid, commonly employed as fire resistant hydraulic oil, shorten bearing life because of its low lubricating property. This DOWMAX motor is equipped with internal flushing circuit in order to extend the bearing life.
- Refer to drawing; DZ5821 B and DZ5861B (with flow control valve).

3. DOWMAX for installing the shaft upward

- With air bleeding hole: An air bleeding hole (with plug) is provided in the end cover in order to facilitate oil filling in the motor casing before operation. Refer to drawing; DZ5823B.
- With special drain port: The highest portion of the motor (when its shaft faces upward) is provided with a special drain port to completely fill the motor casing with oil. Refer to drawing; DZ5822B.

4. DOWMAX motors with speed sensor

- With Shaft encoder type: motor shaft comes with the option, where customer can fit their own encoder
- With Pulse type: motor comes with compact no contact type speed sensor, which can measure 9 to 11 pulse per revolution
- Contact us for any other customized Sensor which needs more accuracy, or specific outputs

5. Coating and rustproofing

- In addition to the standard coating, 8 types of coating system are standardized for DOWMAX motors. Refer to drawing; DZ6373B
- The uncoated surfaces (excluding the nameplate) of all DOWMAX motors are rustproofed. This standard rustproofing is valid for approx. three months. Contact us if the storage period will be longer than that or the motor is to be used in a corrosive atmosphere.

6. Others

- Contact us for motors with special capacities, such as 250, 450, and 530 cc/rev.
- Contact us for the cold-resistant specification for operation at temperatures from -25°C to -45°C. (Standard motors are usable up to -25°C.)
- A socket welding type flange is shown in this catalog for main port piping. A screw type flange is also available. Refer to drawing; DZ5831 B (straight flange, screw connection) and DZ5852B (elbow flange, screw connection).

DOWMAX two-speed motor

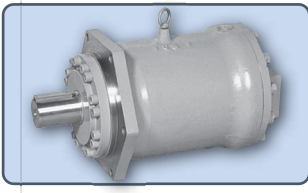

The structure of this two-speed motor is simple because of a construction where the front and rear piston travel independently, making use of the advantages of the opposed piston and double swash plates motor.

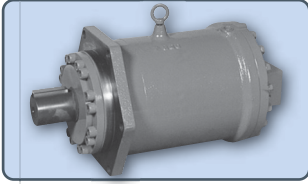

- **High starting efficiency** - Because of the same working structure as standard DOWMAX motor.
- **Good low-speed performance** - Because of multiple-piston construction.
- **Slim configuration** - Motor diameter is same as standard DOWMAX motor.
- **Change-over between large and small displacement can be done while running with a load.**
- **No separate pilot pressure is required for change-over because of the self pressure utilized as a pilot pressure.**

Table of contents

Structure, operation, performance data	52
Coding, change-over circuit in two-speed operation	53
MK300.....	54
MK600.....	56
Bearing life and radial load	58

DOWMAX two-speed motor

Performance data

Model	Displacement cm ³ /rev	Rated pressure MPa (kgf/cm ²)	Peak pressure MPa (kgf/cm ²)	Rated torque Nm (kgfm)	Max. speed rpm	Change-over pilot pressure MPa (kgf/cm ²)	Max. pressure for pilot port MPa (kgf/cm ²)	Pilot piston stroke volume cm ³	Mass kg
MK300	304/152	24.5 (250)	31.9 (325)	1190/594 (121/61)	600/800	more than self-pressure min.0.98 (min.10)	31.9 (325)	3.1	60
MK600	602/301	24.5 (250)	31.9 (325)	2350/1180 (240/120)	300/600	more than self-pressure min.0.98 (min.10)	31.9 (325)	4.1	110

- Limit of hydraulic fluid temperature; -20°C~+80°C
- Limit of hydraulic fluid viscosity; 15~500cSt (Advisable fluid viscosity range; 25~100cSt)
- In case motors are used, as it's output shaft to be positioned upward, special specification should be applied. In this case, please contact us.

Construction and working principle

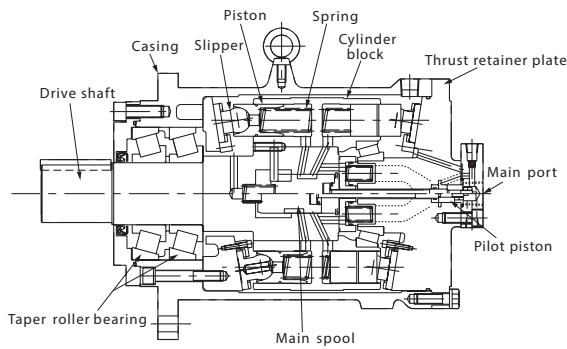

Fig. 1

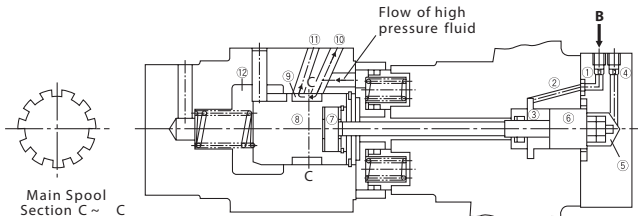

Fig. 2

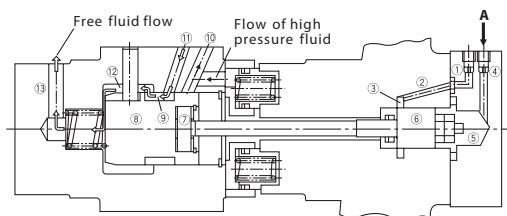

Fig. 3

In the Fig. 1 the high pressure fluid flowing in from the main port enters through the passage in the thrust retainer plate. It then flows into the port which opens at the shaft end surface which slides against the timing plate, and branches into both right and left cylinders.

One flow reaches the piston bores at the right side of the cylinder block, after passing through port holes of the shaft and cylinder block. The other flows into the piston bores at the left side through the groove in the main spool and port holes in the shaft and cylinder block.

Thus the drive shaft starts to rotate through the rotation of cylinder block which is caused by the tangential force on the swash plates exerted by the axial movement of pistons (the pistons are located in the cylinder block which is integral with a drive shaft).

The low-pressure fluid, after working on the pistons, is pushed back by the pistons in the cylinder bore, flows out from the low-pressure main port, through the passage in the reverse way as it came in.

Fig. 2 shows a case of large displacement.

When high pressure fluid is fed to the pilot pressure port B, it arrives at the pilot piston chamber 3 through the passage 1 and 2, and pushes the pilot piston 6 to the right. With the pilot piston 6 pressed to the right side, the main spool 8 also moves to the right by the piston rod 7.

The groove 9 on the main spool comes to the position shown in Fig. 2. With this movement of the main spool, the high pressure fluid coming from the main port flows into both passages of 10 and 11 and exerts force on the right and left pistons, thus working as a large displacement motor.

Fig. 3 shows a case of small displacement.

When high pressure fluid is fed to the pilot pressure port A, it flows to the pilot piston chamber 5 through the passage 4, and pushes the pilot piston 6 to the left. With the movement of the pilot piston 6 to the left side, the main spool 8 also moves to the left by the piston rod 7.

The groove 9 on the main spool comes to the position shown in Fig. 3. With this movement of the main spool, the high pressure fluid coming from the main port flows only to the passage 10, exerting force only on the right pistons thus working as a small displacement motor.

In this case, although high pressure fluid does not flow to the left side pistons, it reciprocates in the cylinders repeating suction and discharge stroke along with the shaft rotation. This is made possible because the groove 9 around the main spool is positioned as shown by which each left side cylinder is channeled through the passage 12. Further, as the passage 12 is connected with the hole 13, fluid is supplied and cooled through the flow to the drain.

DOWMAX two-speed motor

Model code & symbols

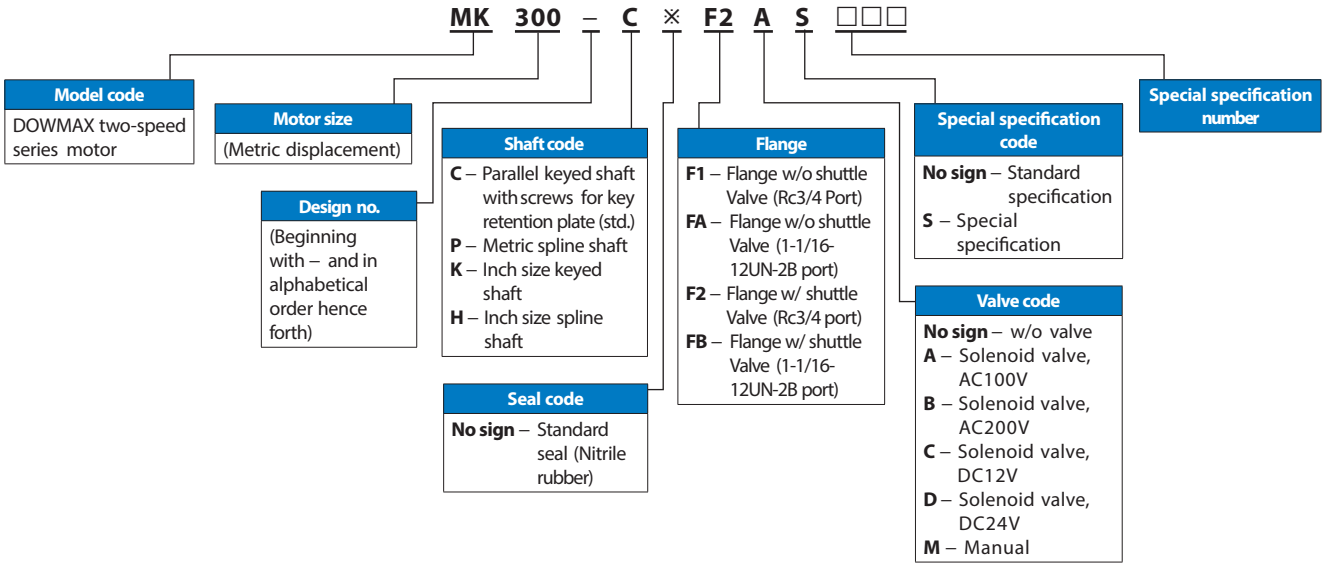

Change-over circuit in two-speed operation

(Basic conditions of a changeover operation)

1. The change-over pilot pressure is basically self-pressure.
However, when a separate pilot pressure other than system-pressure is used, it must be higher than the system-pressure.
2. When the system-pressure is utilized as the pilot pressure for the change-over, the change-over can not be done if the system-pressure is below 1MPa (10 kgf/cm²). (If back-pressure exists at the low pressure side of the change-over pilot pressure, the system-pressure must be larger than the back pressure by 1MPa (10 kgf/cm²) or more.)

(Example of 2-speed change-over circuit)

1. Where a F2 flange with solenoid valve is used.

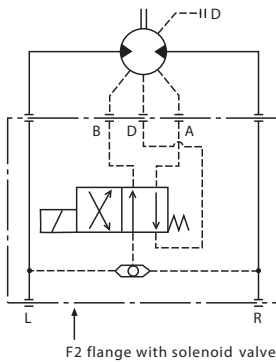

2. Where a F2 flange with manual valve is used.

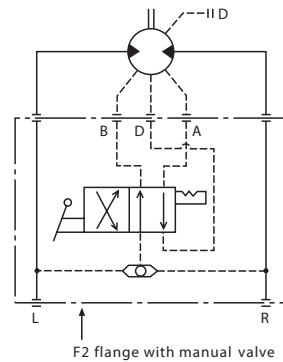

3. Where a F2 flange is used.

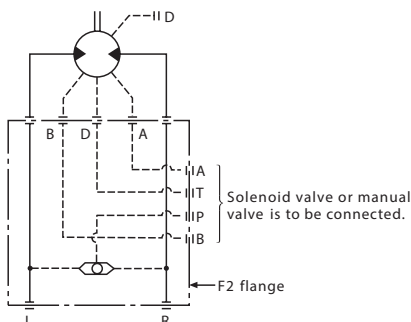

4. Where a F1 flange (without shuttle valve) is used.

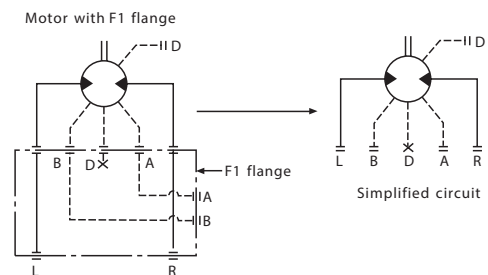

DOWMAX two-speed motor

MK300

Displacement	304/152cm ³ /rev
Rated pressure	24.5MPa (250kgf/cm ²)
Peak pressure	31.9MPa (325kgf/cm ²)
Rated torque	1190/594Nm (121/61kgfm)
Max. Speed	600/800rpm
Change-over pilot pressure	more than self-pressure, Min.0.98MPa (10kgf/cm ²)
Max. pressure for pilot port	31.9MPa (325kgf/cm ²)
Pilot piston stroke volume	3.1cm ³
Mass	60kg

Nominal dimensions

MK300-CF1

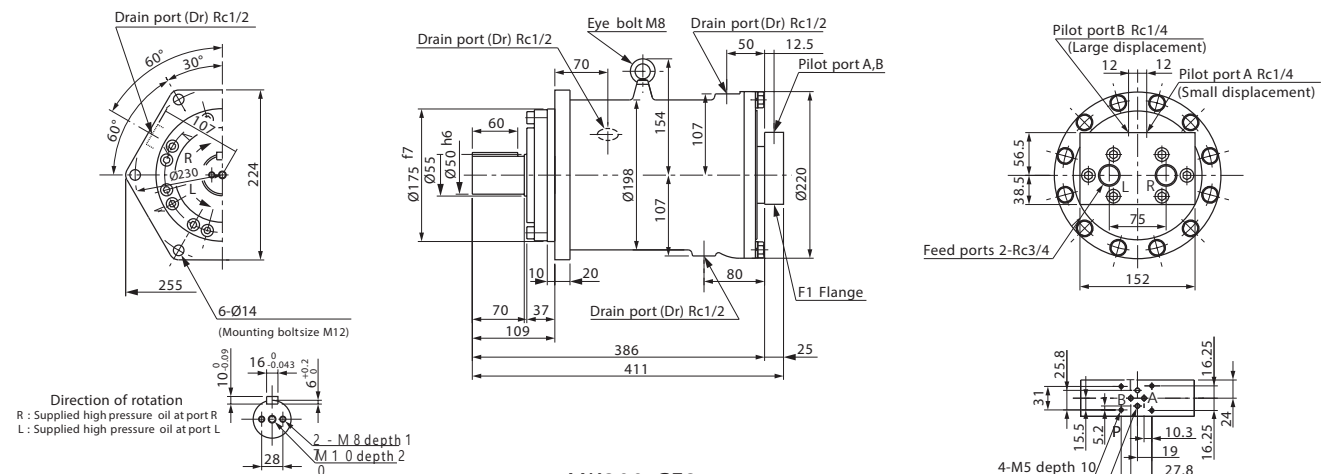

MK300-CF2

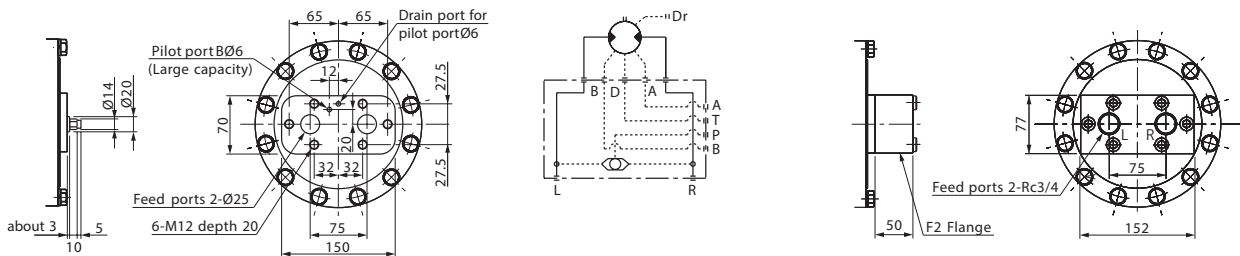

MK300-CF2A ~ D

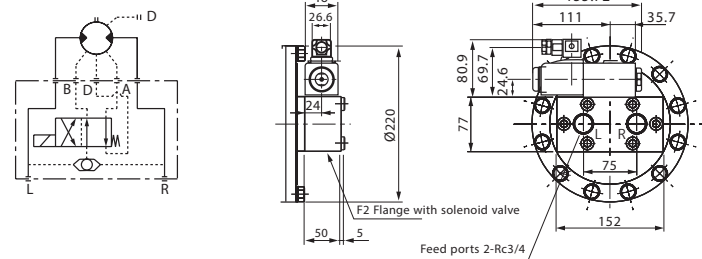

MK300-CF2M

Change of capacity
 Large displacement: Solenoid valve off
 Small displacement: Solenoid valve on

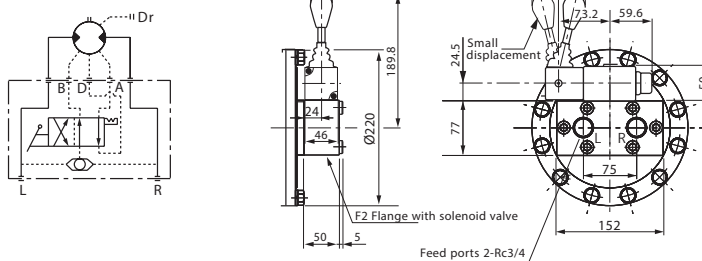

Change of capacity
 Large displacement: Operate the lever to the right
 Small displacement: Operate the lever to the left

DOWMAX two-speed motor

Performance data

Fluid: Shell tellus 56 (Viscosity 37cSt at 50°C)

The graphs shown are mean values obtained for production units.

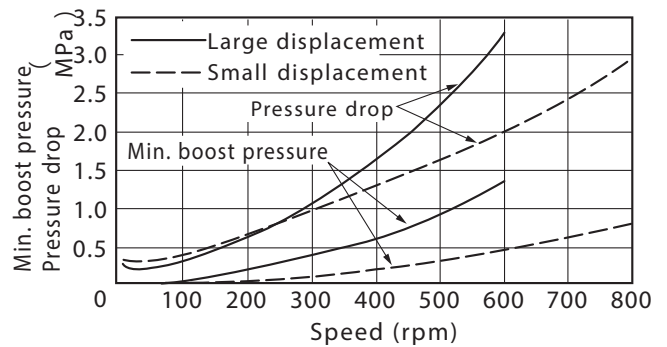
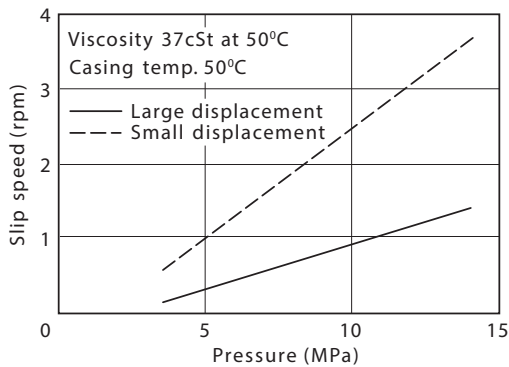
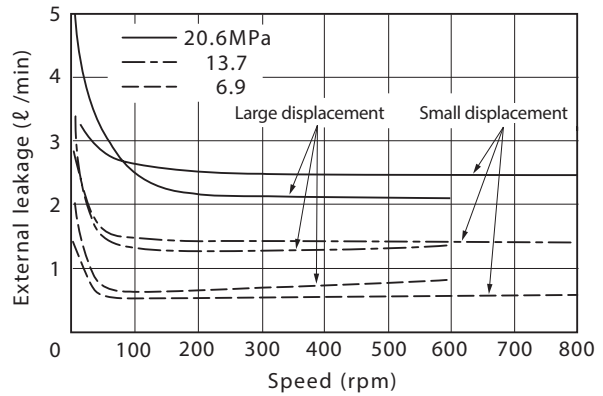
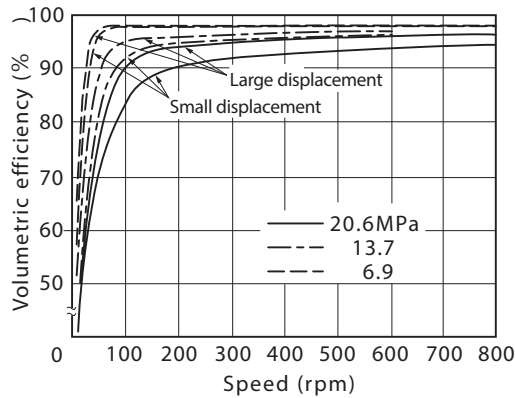
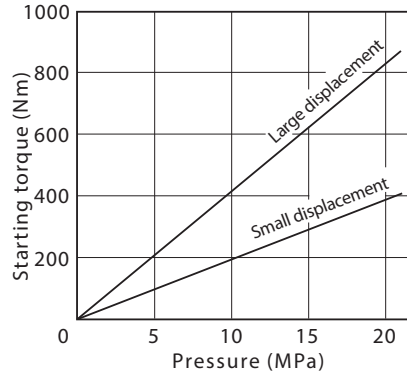
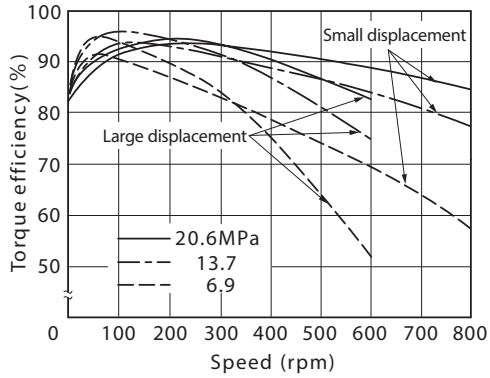

DOWMAX two-speed motor

MK600

Displacement	602/301cm ³ /rev
Rated pressure	24.5MPa (250kgf/cm ²)
Peak pressure	31.9MPa (325kgf/cm ²)
Rated torque	2354/1177Nm (240/120kgfm)
Max. Speed	300/600rpm
Change-over pilot pressure	more than self-pressure, Min.0.98MPa (10kgf/cm ²)
Max. pressure for pilot port	31.9MPa (325kgf/cm ²)
Pilot piston stroke volume	4.1cm ³
Mass	110kg

Nominal dimensions

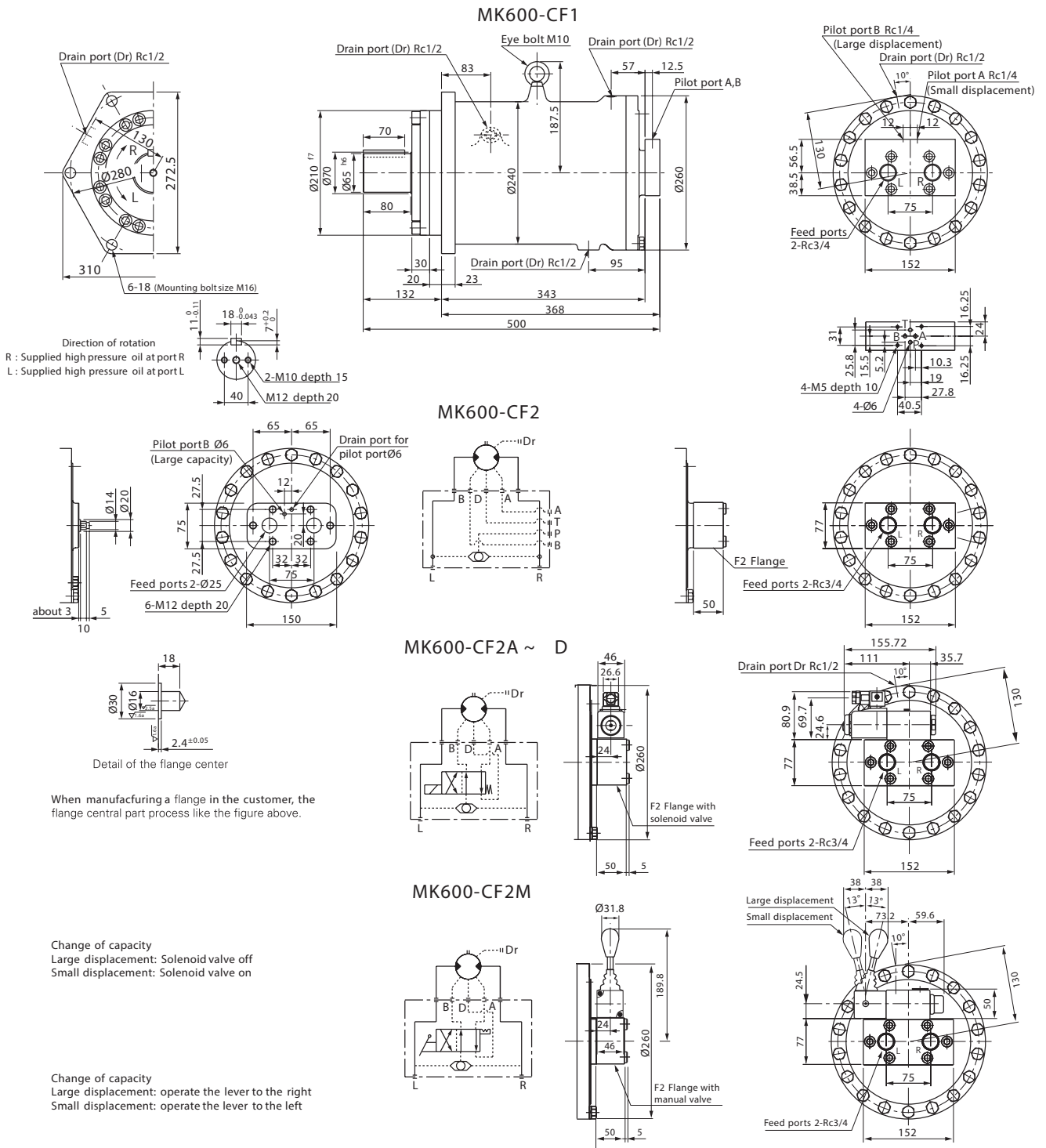

DOWMAX two-speed motor

Performance data

Fluid: Shell tellus 56 (Viscosity 37cSt at 50°C)

The graphs shown are mean values obtained for production units.

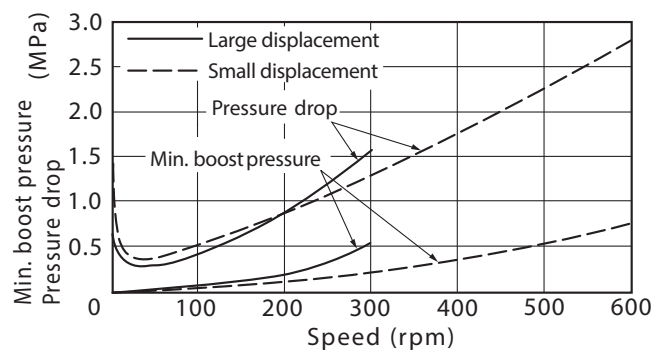
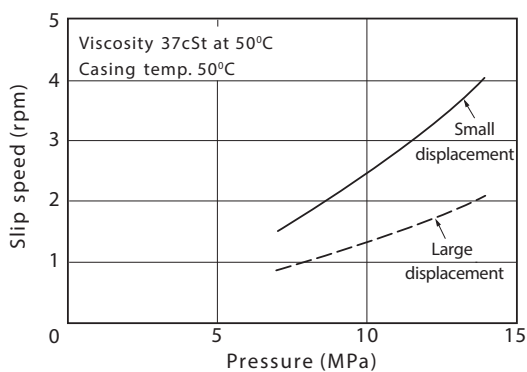
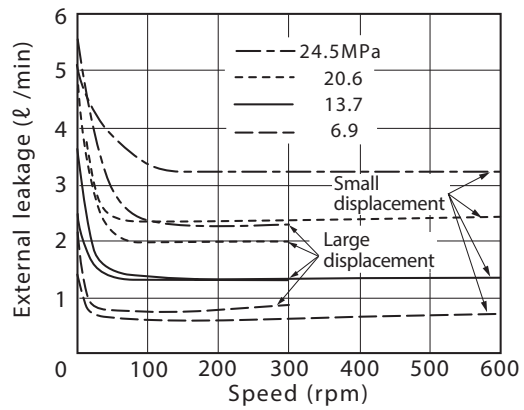
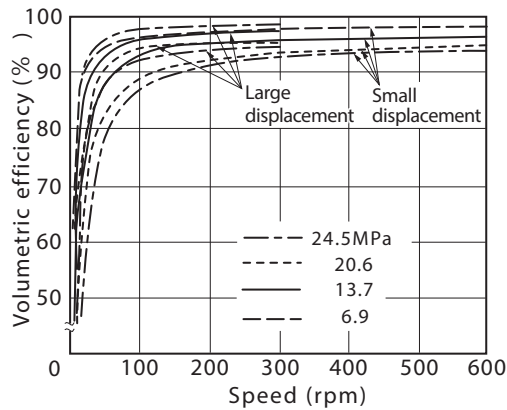
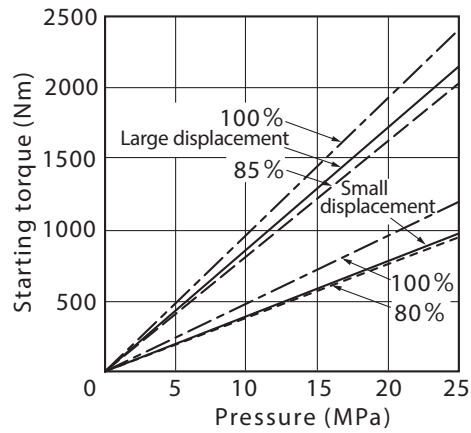
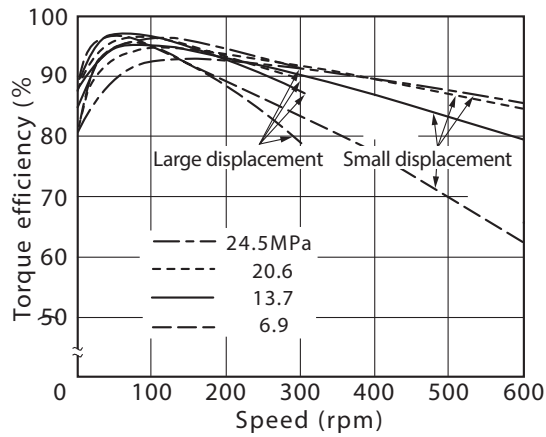

DOWMAX two-speed motor

Bearing life and allowable radial load for shaft

MK300

Allowable max. radial load

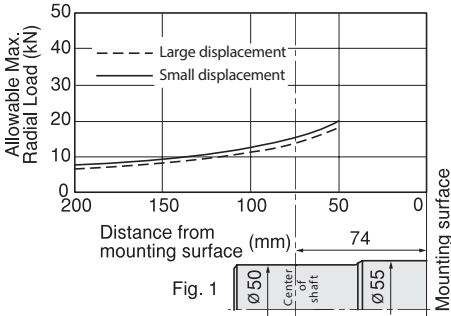

Bearing life

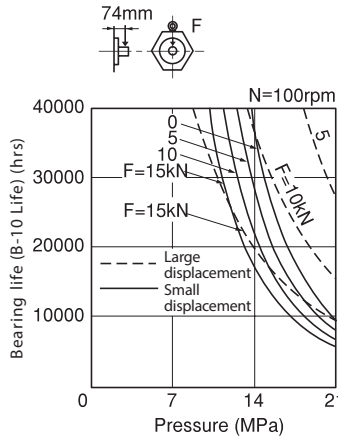

Fig. 2

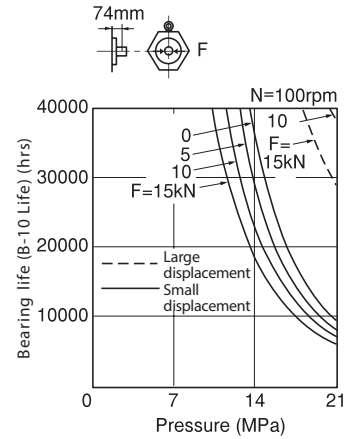
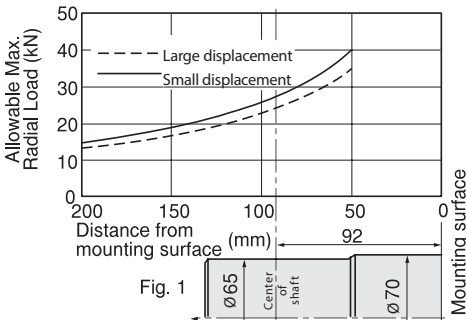

Fig. 3

MK600

Allowable max. radial load



Bearing life

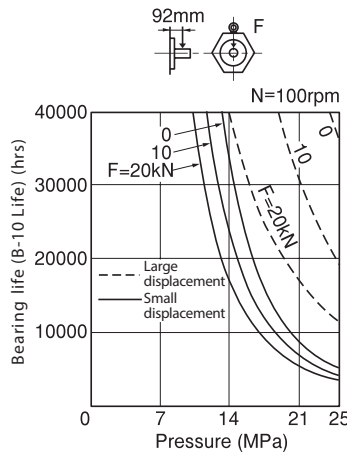

Fig. 2

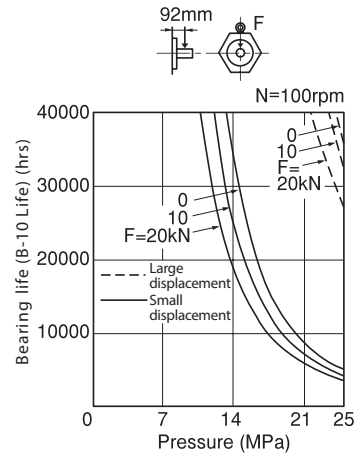

Fig. 3

- Note:**
- If motors are operated within the proper ratings and conditions, the operational life is determined by the Bearing Life.
 - In order to maintain the maximum bearing life, when a radial load is imposed on the output shaft the motor should be installed as illustrated in Fig. 2 or Fig. 3.
For a uni-directional application, motor should be installed so that side load acts as shown in Fig. 2.
For a bi-directional application, a radial load for each rotational direction being applied, the motor should be installed so that side loads act as shown in Fig. 3.
 - The graphs shown are the bearing life (B-10 Life) at 100 rpm shaft speed for various pressures and radial loads.
When the shaft speed differs from 100 rpm the bearing life can be obtained by the following formula:

$$\text{B-10 Life} = (\text{Bearing life obtainable in the graph}) \times \frac{100}{\text{Actual shaft speed, rpm}}$$

In case where the side load acts at a different location to the midpoint of the shaft projection please refer to us.

- Applications with axial thrust loads should be referred to us.
- When motor is used in Meter-Out circuit, pressure in Fig. 2 & 3 shaft be a sum of motor inlet and outlet pressure.
- Bearing life varies due to kind of fluid. Bearing life should be decided by multiplying by the factor recommended:

Fluid type	life factor
Mineral-based fluid	1.0
Phosphate-ester fluid	1.0
Water-glycol w/o forced lubrication	0.05~0.10
Water-glycol w/ forced lubrication	0.6

DOWMAX with mechanical brake

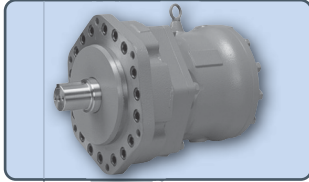
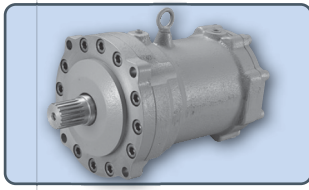

This brake is a wet multi-disc type and is of a pressure-release type (negative brake type) where the brake is on at all time and is released only when the pilot fluid is led through the brake releasing port. Any adjustment after initial installation is not required.

The mechanical brake provides the following two types. Select one depending on application.

- Cartridge type mechanical brake which enables easy mounting and dismounting with the hydraulic motor (BB, BC, BP, BR types)
- Integral shaft type mechanical brake which is compact and light weight (MB type)
 - The mechanical brake is highly durable as it has adopted wet type multiple discs/plates.
 - Having a large torque capacity, it is suited for a wide range of applications.
 - Safe operation is ensured as it is a pressure-release type (brake is only released by applying pressure).
 - Being compact in construction, it is easy to design its installation on any equipment.
 - It provides a large radial load capability, because of a large capacity roller bearing being adopted on the drive shaft.
 - The brake motor has a quick access for servicing as the removal of either brake or motor can easily be made.

Table of contents

Structure, operation, performance data, examples of application	60
MB100-C40	62
MB150AP100	64
MB175AP100	64
MB300BP150	66
MB350BP150	66
ME600BCS2550+BB250BC	68
ME750BCS2560+BC300-C	70
ME850BCS2570+BC300-C	70
MK300-FS001+BP121-C	72
MK600-CS002+BR250-C	74

DOWMAX with mechanical brake

Structure & operating principle

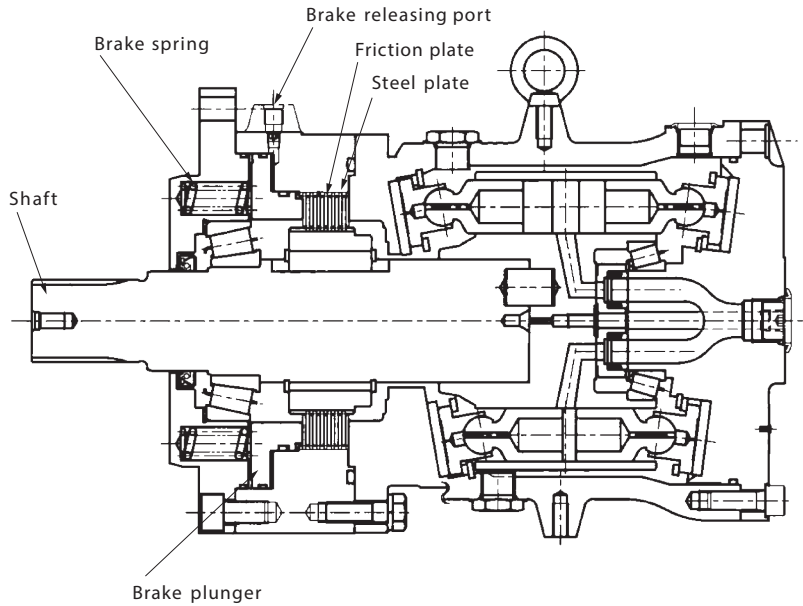

Structure of integral shaft type mechanical brake
(MB type: Above drawing shows MB300B.)

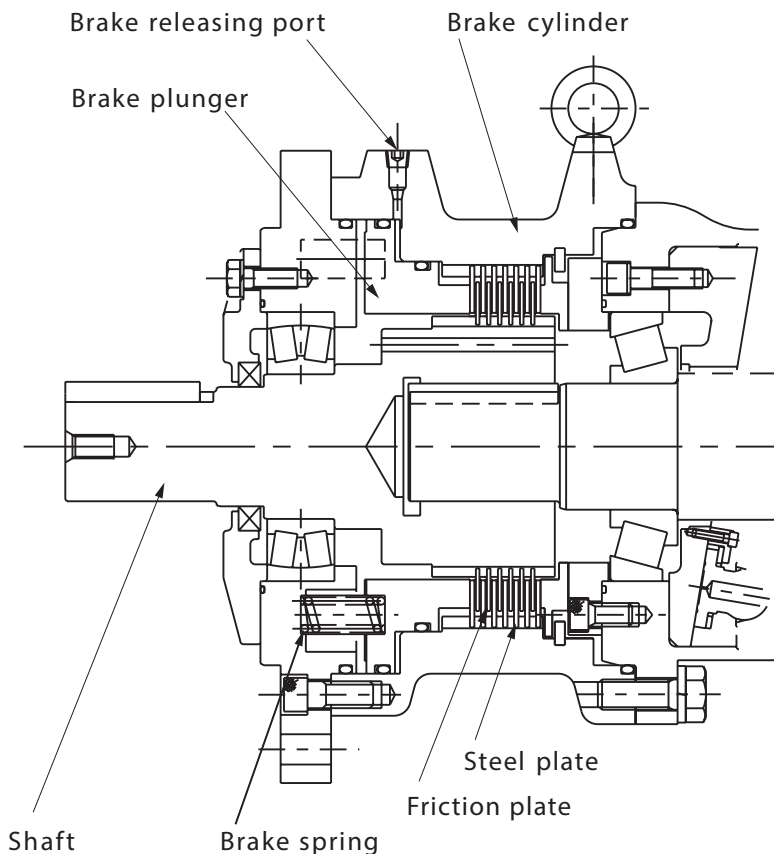

Structure of cartridge type mechanical brake (BB, BC, BP, BR types)

The internal structure of the mechanical brake is shown above. The friction plates and steel plates are located one side the other, and the braking torque is generated by the friction force applied when the spring presses these plates. The friction plates are placed on the splined drive shaft for cartridge type and on the brake spline for integral shaft type, which are connected to the motor shaft with a key. The steel plates are placed on the brake cylinder for cartridge type and brake plunger for integral shaft type by splines. The braking torque is generated by the force of the spring, and when a pressure higher than a spring force is applied in the brake releasing port, the friction plates and steel plates are separated and the brake is released. When the pressure at the brake releasing port is lowered, the brake plunger is pressed against the friction plate by the spring force, and the brake torque is generated by the friction force between the plates.

DOWMAX with mechanical brake

Performance data

Model	Hydraulic motor						Mechanical brake				Mass
	Displacement	Rated pressure	Peak pressure	Rated torque	Rated speed	Max. speed	Static brake torque	Brake releasing pressure	Max. pressure for cylinder	Brake cylinder stroke volume	
	cm ³ /rev	MPa (kgf/cm ²)	MPa (kgf/cm ²)	Nm (kgfm)	rpm	rpm	Nm (kgfm)	MPa (kgf/cm ²)	MPa (kgf/cm ²)	cm ³	kg
MB100-C40	99	27.5 (280)	31.9 (325)	432 (44)	1000	1000	392 (40)	1.23 (12.5)	31.9 (325)	13	34
MB150AP100	152			667 (68)	600	800	980 (100)	1.0 (10)		20	71
MB175AP100	175			765 (78)	600	800					
MB300BP150	300			1320 (134)	660	800	1470 (150)	89			
MB350BP150	350			1530 (156)	660	800					
ME600BCS2550+BB250BC	600			2620 (267)	500	600	2450 (250)	1.2 (12)		58	190
ME750BCS2560+BC300-C	750			3280 (334)	450	520	2940 (300)				217
ME850BCS2570+BC300-C	848			3700 (377)	400	450	1190 (121)	37		102	
MK300-FS001+BP121-C	304			1190 (121)	600	600					
	152			594 (61)	800	800					
MK600-CS002+BR250-C	602	2350 (240)	300	300	2450 (250)	58			204		
	301	1180 (120)	600	600							

Examples of application

Winch circuit.

A case where the mechanical brake is applied to hold the load, when a change-over lever at neutral.

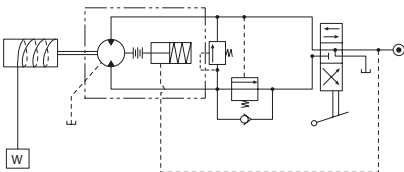

Truck (carrier) drive circuit.

A case where the mechanical brake is used in combination with counter balance valve with brake valves, for traction drive use.

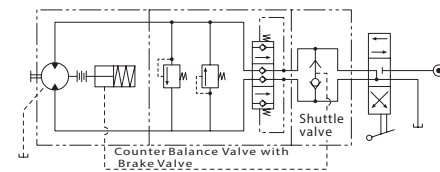

A case where the mechanical brake is used in combination with brake valve, for traction drive use.

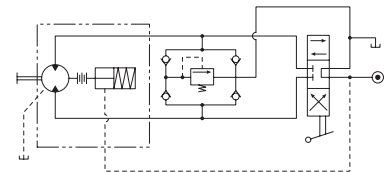

When this mechanical brake is used as dynamic brake, the friction plate will slip against steel plate, and in some cases excessive heat would be generated by friction. In such a case, please contact us.

Brake characteristics

The Brake torque is generated in proportion to the force exerted between the friction plates and steel plates. Therefore, the brake torque varies with the pressure at the brake releasing port and the drain pressure in the motor case. Every displacement have a specific curve, which is shown in respective motor brake characteristic graph, to show the relationship between the brake torque vs. the pressure at the brake releasing port and the drain pressure in the motor case.

Brake torque varies due to unevenness of friction coefficient between friction plate and steel plate, these curves shows the lower limit of these values.

CAUTION: In case motors are used as it's output shaft to be positioned upward, some modification would be necessary. In this case, please contact us.

- Note:**
- If motors are operated within the proper ratings and conditions, the operational life is determined by the Bearing Life.
 - In order to maintain the maximum bearing life, when a radial load is imposed on the output shaft the motor should be installed as illustrated in Fig. 2 or Fig. 3.
For a uni-directional application, motor should be installed so that side load acts as shown in Fig. 2.
For a bi-directional application, a radial load for each rotational direction being applied, the motor should be installed so that side loads act as shown in Fig. 3.
 - The graphs shown are the bearing life (B-10 Life) at 100 rpm shaft speed for various pressures and radial loads. When the shaft speed differs from 100 rpm the bearing life can be obtained by the following formula:

$$\text{B-10 Life} = (\text{Bearing life obtainable in the graph}) \times \frac{100}{\text{Actual shaft speed, rpm}}$$

Caution : In case where the side load acts at a different location to the midpoint of the shaft projection please refer to us.

DOWMAX with mechanical brake

MB100-C40

Hydraulic motor	Displacement	99cm ³ /rev
	Rated pressure	27.5MPa (280kgf/cm ²)
	Peak pressure	31.9MPa (325kgf/cm ²)
	Rated torque (theoretical)	432Nm (44kgfm)
	Rated speed	1000rpm
	Max. speed	1000rpm
Mechanical brake	Static brake torque	392Nm (40kgfm)
	Brake releasing pressure	1.2MPa (12.5kgf/cm ²)
	Endurable press. of brake cylinder	31.9MPa (325kgf/cm ²)
	Brake cylinder stroke volume	13cm ³
GD ²	0.08kgm ²	
Casing capacity	0.7 ℓ	
Mass	34kg	

Outline dimensions

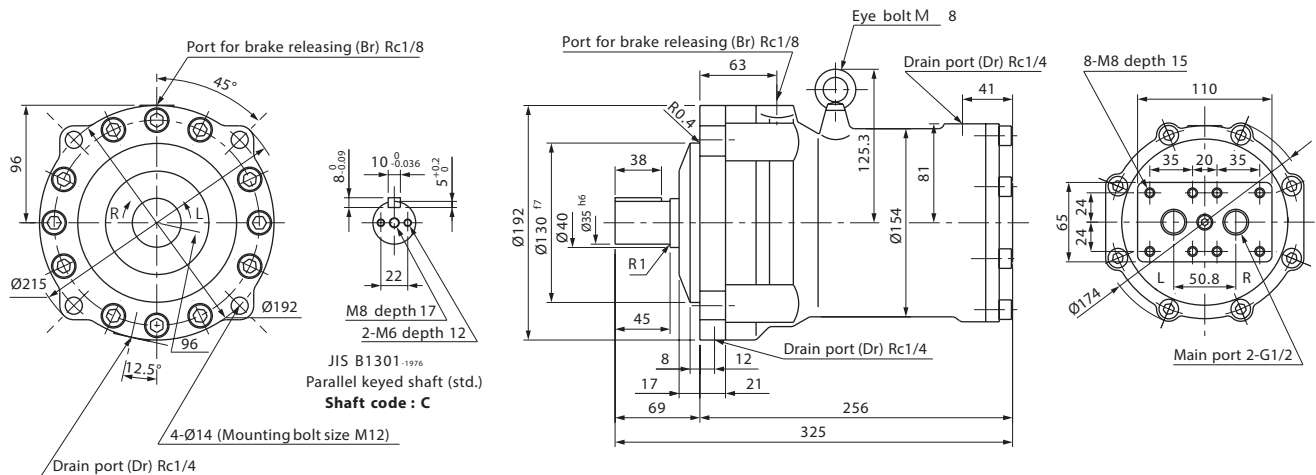

Direction of rotation

R : Supplied high pressure oil at port R

L : Supplied high pressure oil at port L

Spline shaft

Shaft code : P

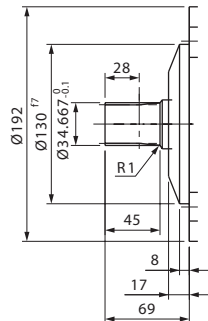
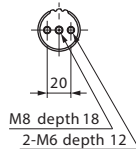

JIS D2001 Involute spline 35 × 19 × 1.667 (Class b)

Tool	Coefficient of profile shifting	+ 0.800
	Tooth form	Stub tooth
Pressure angle	Module	1.667
	Pressure angle	20°
Number of teeth	19	
Shaft thickness	Dia. of basic pitch circle	31.667
	Grade	Class b (flank fit)
Tooth thickness	Over-pin dia.	37.819 ^{-0.019} -0.110
	Overall across a given number of teeth (reference)	Pin dia.=Ø3.0 13.656 ^{-0.002} -0.058
Outer dia.	34.667	
Inner dia.	31.000	

DOWMAX with mechanical brake

Coding

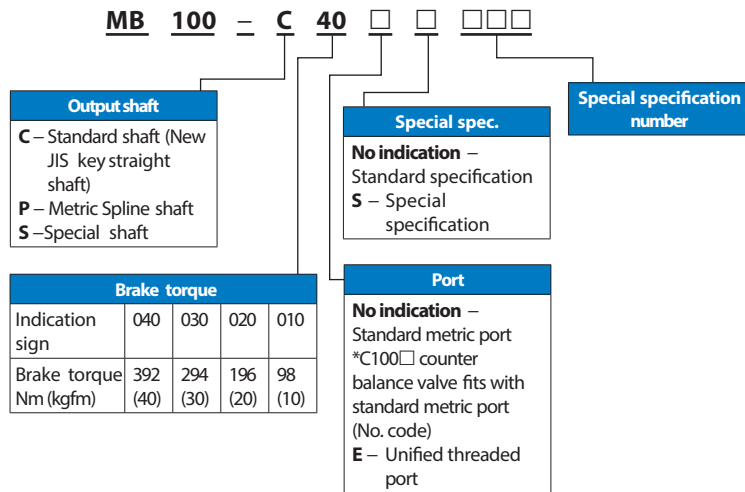

Brake characteristics

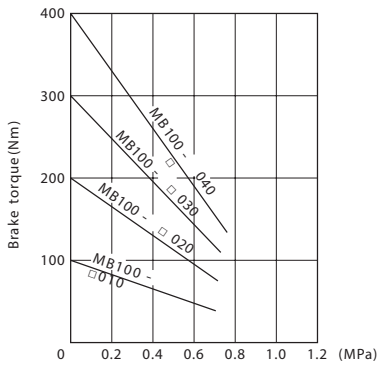

(Pressure at brake releasing port) minus (Drain pressure in case)

Allowable radial load

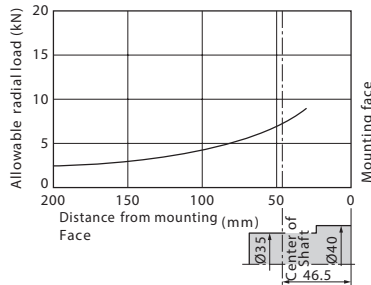

Bearing life

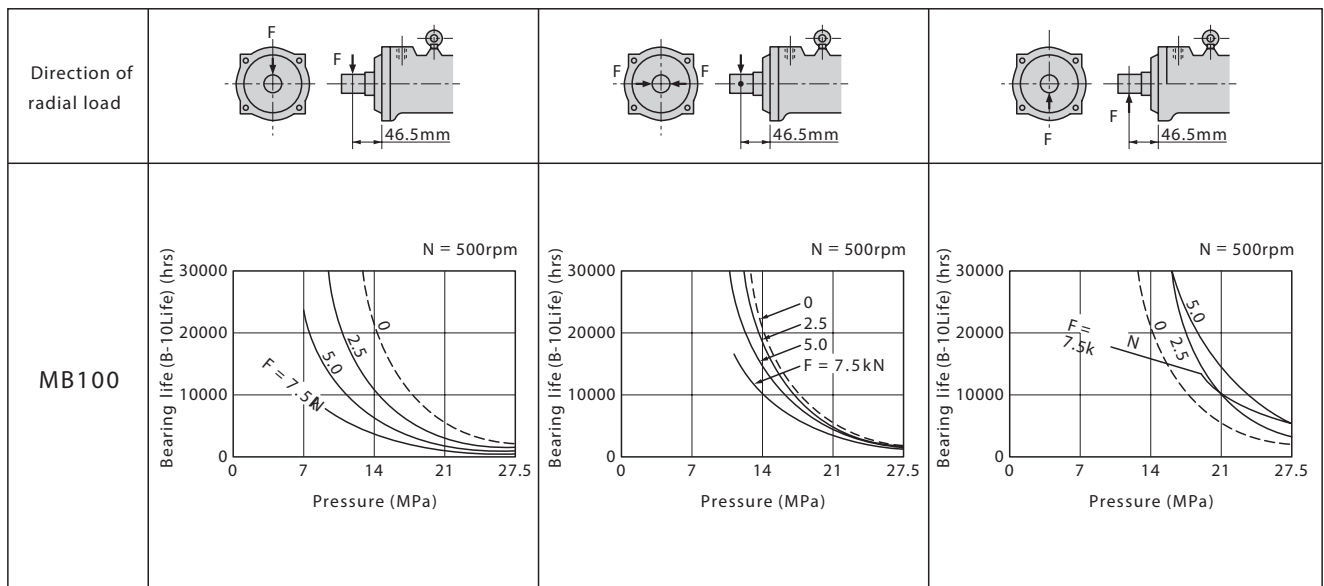

DOWMAX with mechanical brake

MB150AP100

MB175AP100

Hydraulic motor	Displacement	152	175	cm ³ /rev
	Rated pressure	27.5 (280)		MPa (kgf/cm ²)
	Peak pressure	31.9 (325)		MPa (kgf/cm ²)
	Rated torque (theoretical)	667 (68)	765 (78)	Nm (kgfm)
	Rated speed	600		rpm
	Max. speed	800		rpm
Mechanical brake	Static brake torque	981 (100)		Nm (kgfm)
	Brake releasing pressure	1.0 (10)		MPa (kgf/cm ²)
	Endurable press. of brake cylinder	31.9 (325)		MPa (kgf/cm ²)
	Brake cylinder stroke volume	20		cm ³
GD ²	0.25		kgm ²	
Casing capacity	1.0		ℓ	
Mass	71		kg	

Outline dimensions

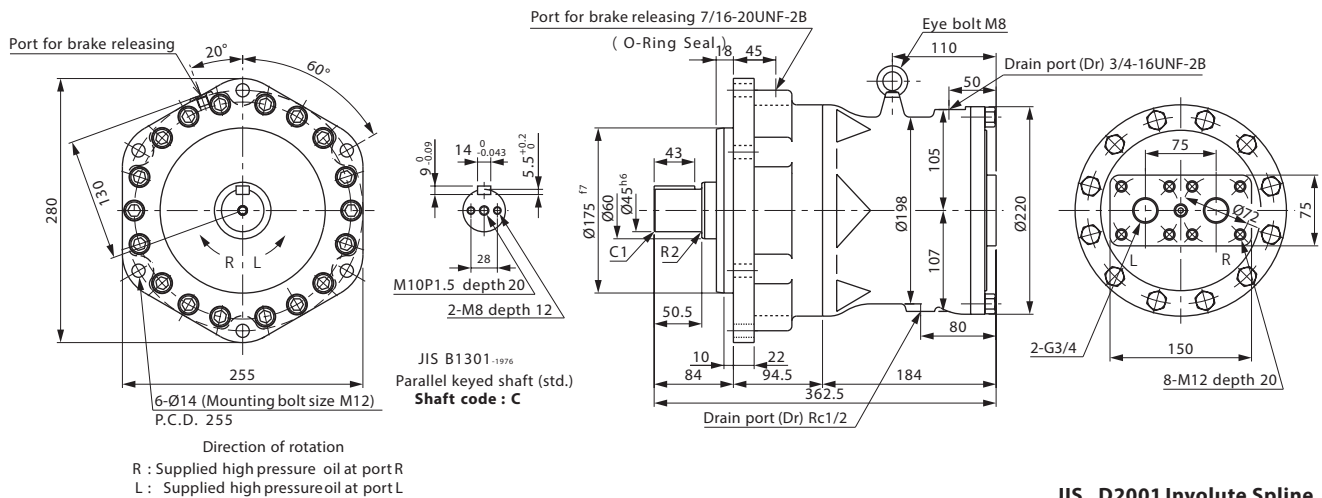

Spline shaft Shaft code : P

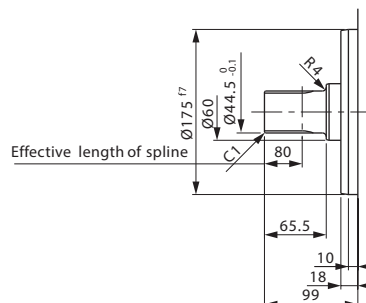
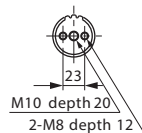

JIS D2001 Involute Spline 45 x 16 x 2.5 (Class b)

Tool	Coefficient of profile shifting	+ 0.800
	Tooth form	Stub tooth
Tooth thickness	Module	2.5
	Pressure angle	20°
Shaft	Number of teeth	16
	Dia. of basic pitch circle	40
Shaft thickness	Grade	Class b (flank fit)
	Over-pin dia.	49.277 ^{+0.018} _{-0.107} Pin dia.=Ø4.5
Tooth thickness	Overall across a given number of teeth (reference)	20.379 ^{+0.001} _{-0.058} (3-teeth)
	Outer dia.	44.5
	Inner dia.	39

DOWMAX with mechanical brake

Coding

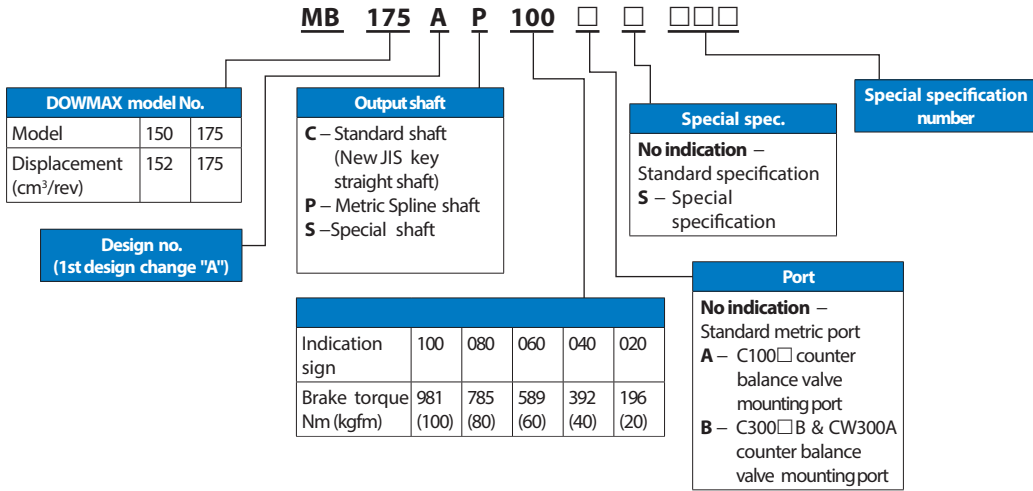

Brake characteristics

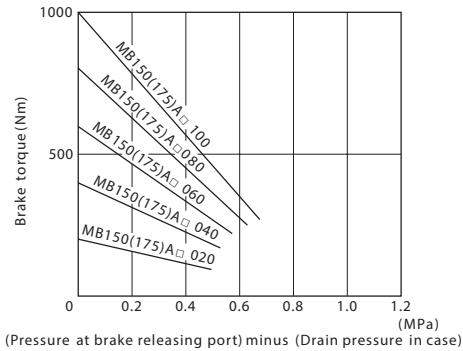

Allowable radial load

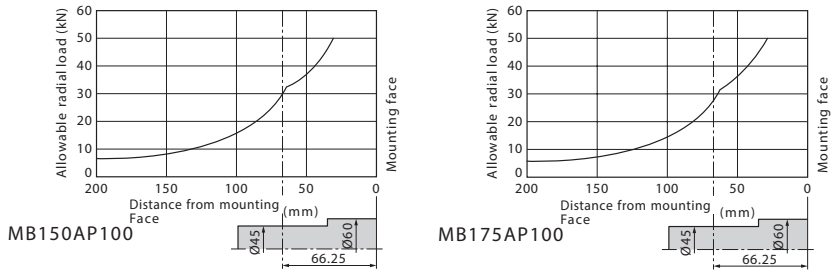

Bearing life

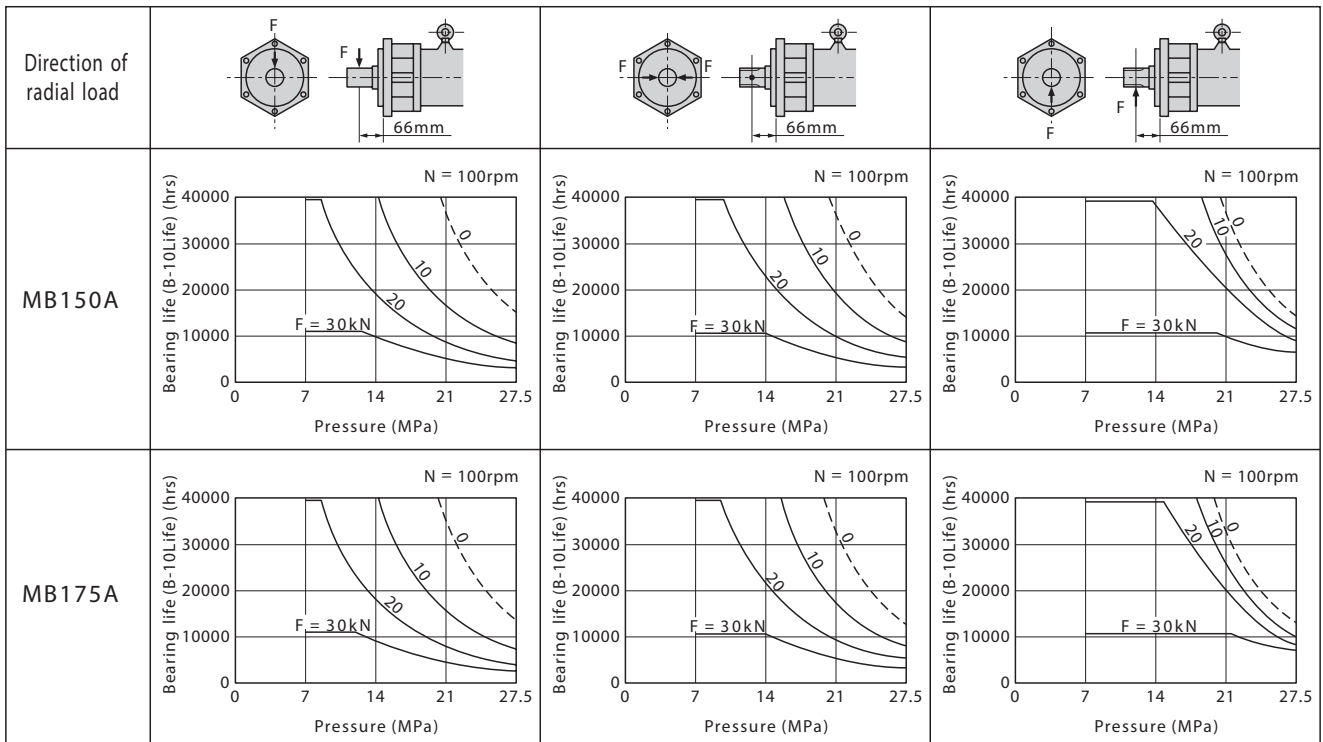

DOWMAX with mechanical brake

MB300BP150

MB350BP150

Hydraulic motor	Displacement	300	350	cm ³ /rev
	Rated pressure	27.5 (280)		MPa (kgf/cm ²)
	Peak pressure	31.9 (325)		MPa (kgf/cm ²)
	Rated torque (theoretical)	1320 (135)	1530 (156)	Nm (kgfm)
	Rated speed	660		rpm
	Max. speed	800		rpm
Mechanical brake	Static brake torque	1470 (150)		Nm (kgfm)
	Brake releasing pressure	1.2 (12)		MPa (kgf/cm ²)
	Endurable press. of brake cylinder	31.9 (325)		MPa (kgf/cm ²)
	Brake cylinder stroke volume	20		cm ³
GD ²	0.28		kgm ²	
Casing capacity	1.5		ℓ	
Mass	89		kg	

Outline dimensions

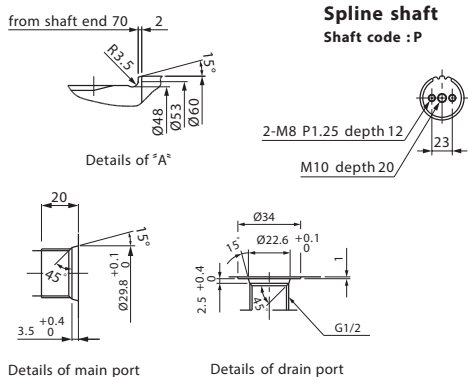
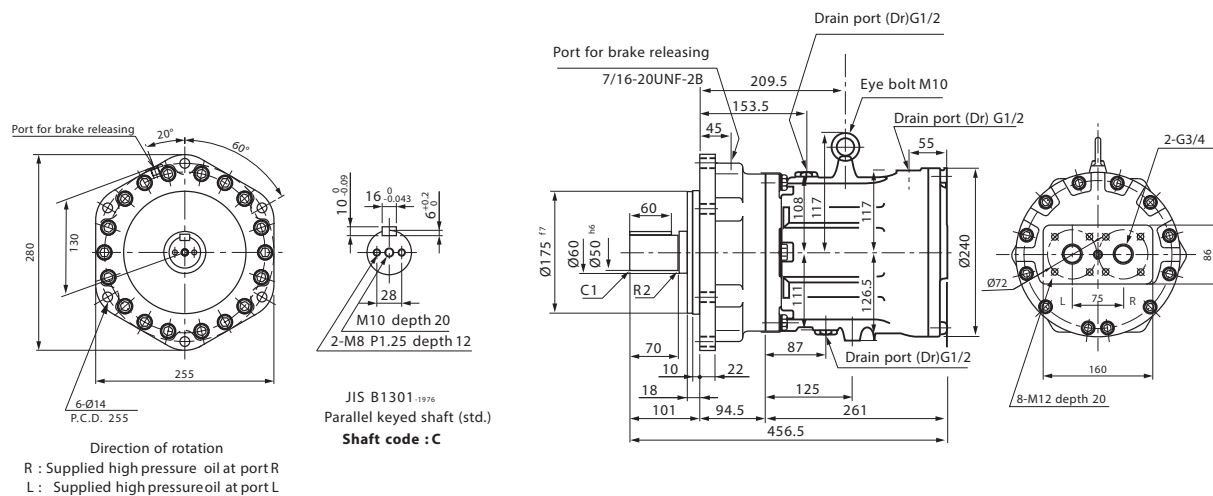

JIS D2001 Involute spline 50 × 18 × 2.5 (Class b)

Tool	Coefficient of profile shifting	+ 0.800
	Tooth form	Stub tooth
Tooth thickness	Module	2.5
	Pressure angle	20°
Number of teeth	Number of teeth	18
	Dia. of basic pitch circle	40
Shaft thickness	Grade	Class b (flank fit)
	Over-pin dia.	54.366 ^{+0.019} _{-0.109} Pin dia.=Ø4.5
Tooth thickness	Over-all, across a given number of teeth (reference)	20.499 ^{+0.001} _{-0.058} (3-teeth)
	Outer dia.	49.5 ⁰ _{-0.1}
Shaft thickness	Inner dia.	44

DOWMAX with mechanical brake

Coding

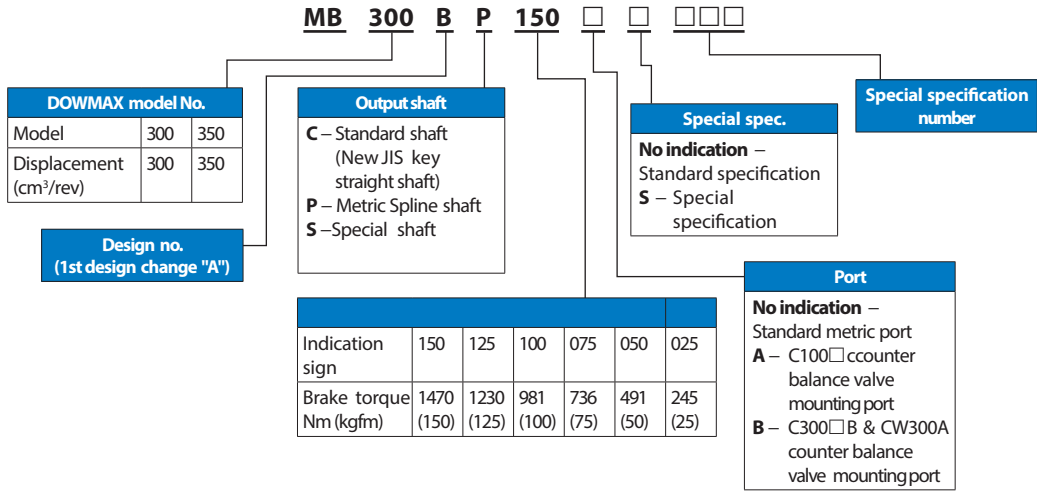

Brake characteristics

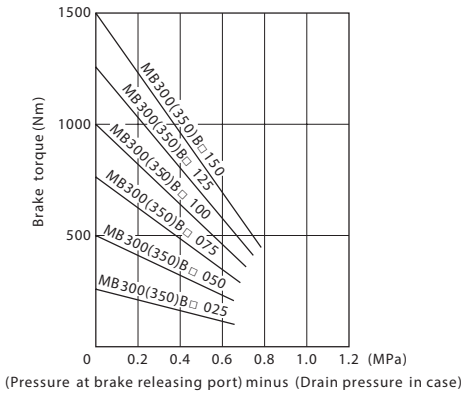

Allowable radial load

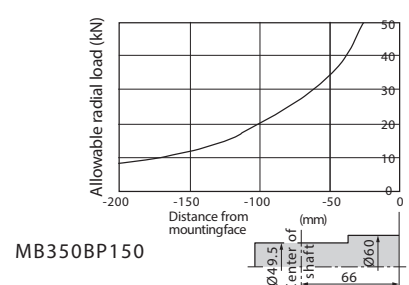
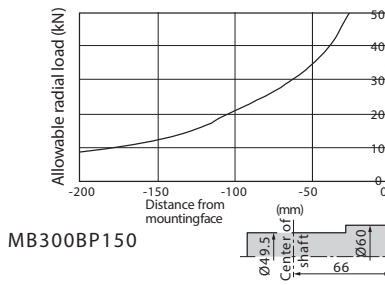

Bearing life

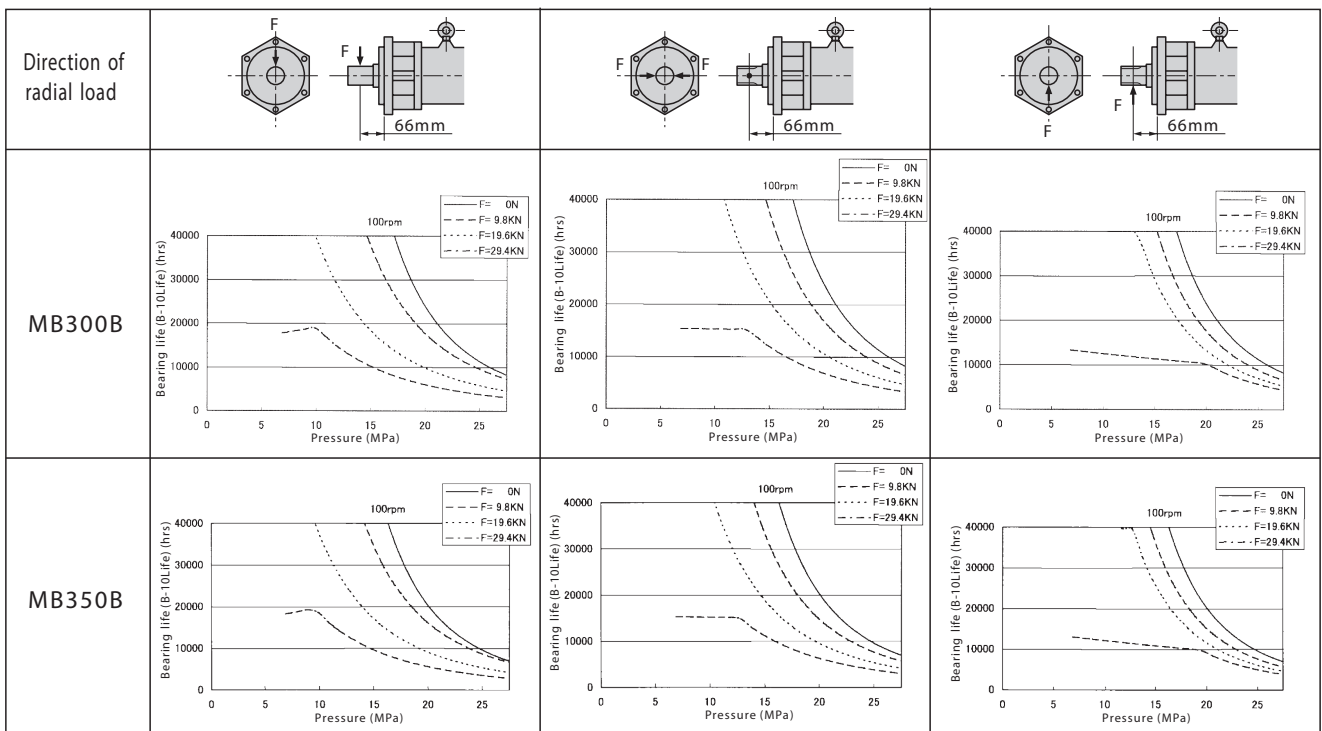

DOWMAX with mechanical brake

ME600BCS2550+BB250BC

Hydraulic motor	Displacement	600cm ³ /rev
	Rated pressure	27.5MPa (280kgf/cm ²)
	Peak pressure	31.9MPa (325kgf/cm ²)
	Rated torque (theoretical)	2620Nm (267kgfm)
	Rated speed	500rpm
	Max. speed	600rpm
Mechanical brake	Static brake torque	2450Nm (250kgfm)
	Brake releasing pressure	1.2MPa (12kgf/cm ²)
	Endurable press. of brake cylinder	31.9MPa (325kgf/cm ²)
	Brake cylinder stroke volume	58cm ³
GD ²	0.91kgm ²	
Casing capacity	2.7ℓ	
Mass	190kg	

Outline dimensions

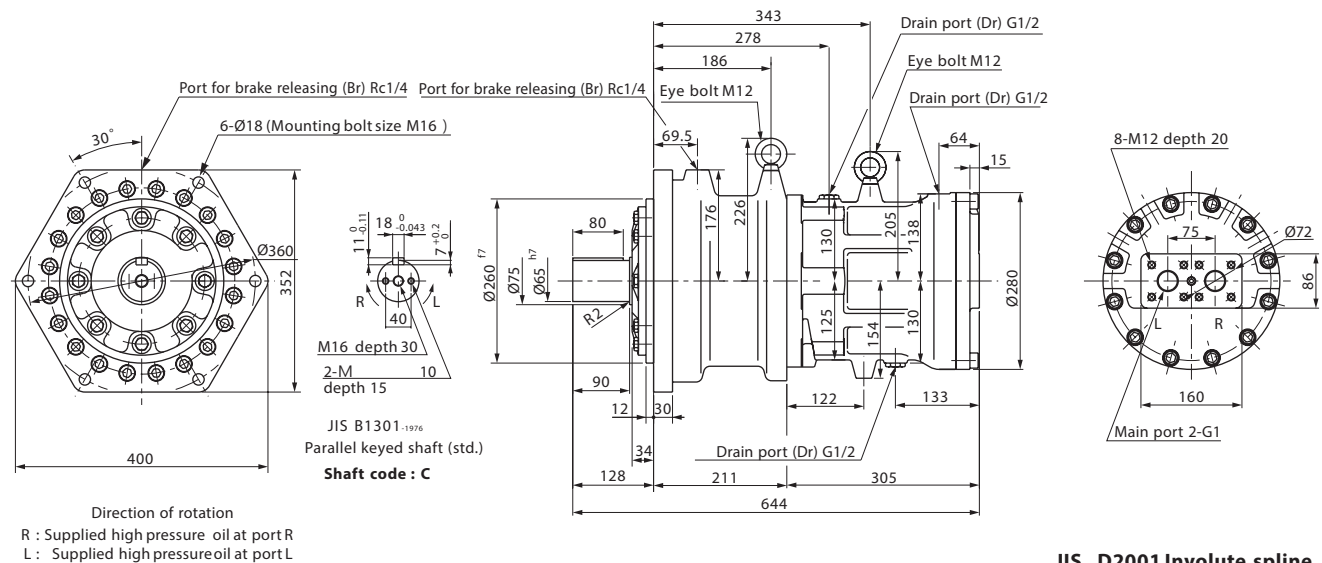

Spline shaft

Shaft code : P

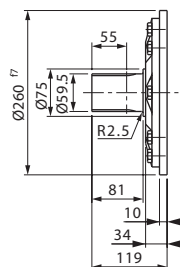
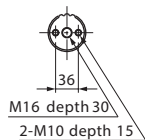

JIS D2001 Involute spline

60 × 22 × 2.5 (Class b)

Tool	Coefficient of profile shifting	+ 0.800
	Tooth form	Stub tooth
Pressure angle	Module	2.5
	Pressure angle	20°
Number of teeth	Number of teeth	22
	Dia. of basic pitch circle	55
Shaft thickness	Grade	Class b (flank fit)
	Over-pin dia.	64.516 ^{±0.020} Pin dia. = Ø4.5
Tooth thickness	Over-all, across a given number of teeth (reference)	27.970
	Outer dia.	59.5 ^{±0.058}
	Inner dia.	54

DOWMAX with mechanical brake

Coding

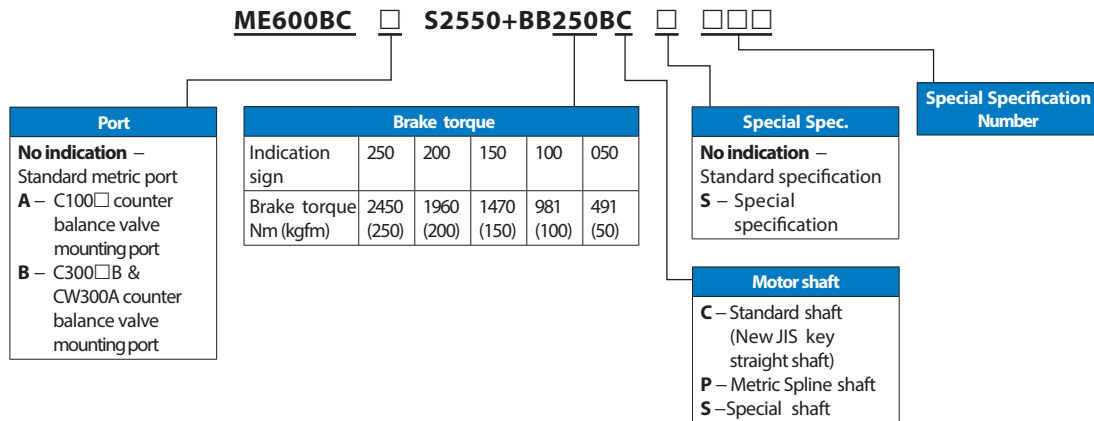

Brake characteristics

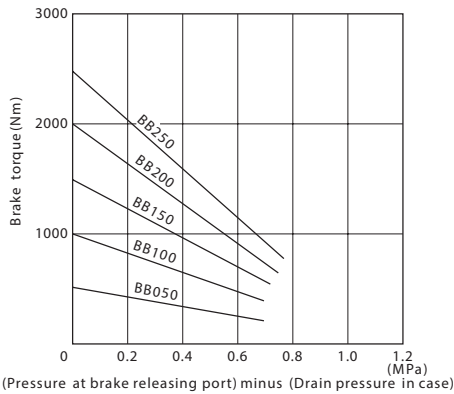

Allowable radial load

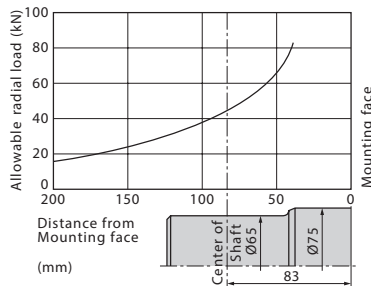

Bearing life

Direction of radial load			
ME600B			

DOWMAX with mechanical brake

ME750BCS2560+BC300-C

ME850BCS2570+BC300-C

Hydraulic motor	Displacement	750	848	cm ³ /rev
	Rated pressure	27.5 (280)		MPa (kgf/cm ²)
	Peak pressure	31.9 (325)		MPa (kgf/cm ²)
	Rated torque (theoretical)	3280 (334)	3708 (378)	Nm (kgfm)
	Rated speed	450	400	rpm
	Max. speed	520	450	rpm
Mechanical brake	Static brake torque	2940 (300)		Nm (kgfm)
	Brake releasing pressure	1.2 (12)		MPa (kgf/cm ²)
	Endurable press. of brake cylinder	31.9 (325)		MPa (kgf/cm ²)
	Brake cylinder stroke volume	58		cm ³
GD ²	1.25		kgm ²	
Casing capacity	3.0		ℓ	
Mass	217		kg	

Outline dimensions

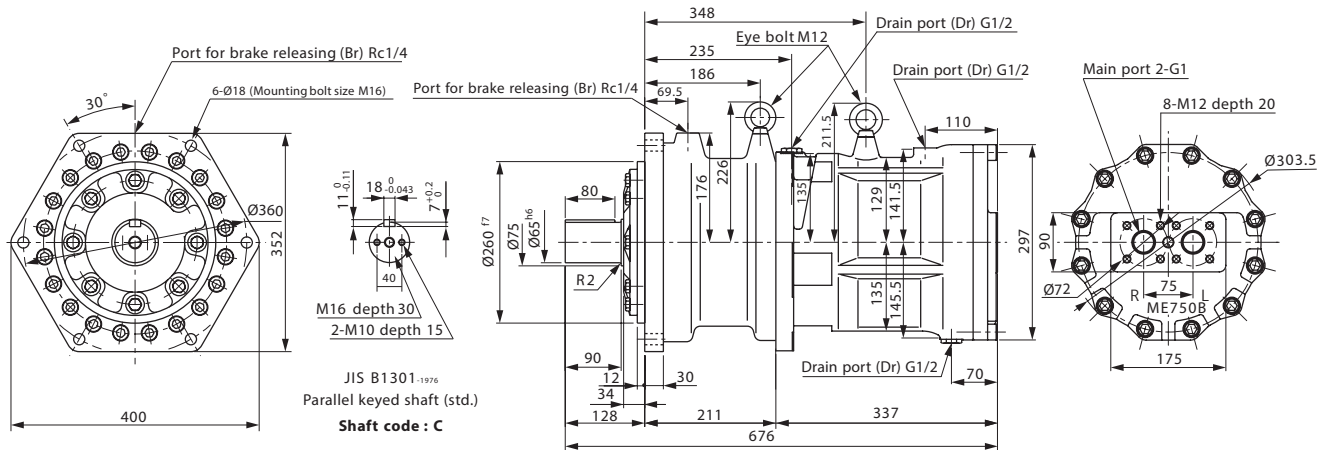

Direction of rotation

R : Supplied high pressure oil at port R
L : Supplied high pressure oil at port L

Spline shaft
Shaft code : P

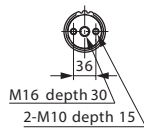

JIS D2001 Involute spline
60 × 22 × 2.5 (Class b)

Tool	Coefficient of profile shifting	+ 0.800
	Tooth form	Stub tooth
Pressure angle	Module	2.5
	Pressure angle	20°
Number of teeth	Number of teeth	22
	Shaft	
Dia. of basic pitch circle	Dia. of basic pitch circle	55
	Grade	Class b (flank fit)
Tooth thickness	Over-pin dia.	64.516 ^{+0.020} Pin dia.=Ø4.5
	Over-all across a given number of teeth (reference)	27.970 (4-teeth)
Outer dia.	Outer dia.	49.5 ^{+0.058}
	Inner dia.	54

DOWMAX with mechanical brake

Coding

ME750BC □ **S2560+** **BC300-C** □ □ □

DOWMAX model No.		
Model	ME750B	ME850B
Displacement (cm ³ /rev)	750	848

Port

No indication – Standard metric port

A – C100□ counter balance valve mounting port

B – C300□B & CW300A counter balance valve mounting port

Motor shaft

C – Standard shaft (New JIS key straight shaft)

P – Metric spline shaft

S – Special shaft

Special specification number

Special spec.

No indication – Standard specification

S – Special specification

Brake torque						
Indication sign	300	250	200	150	100	050
Brake torque Nm (kgfm)	2940 (300)	2450 (250)	1960 (200)	1470 (150)	981 (100)	491 (50)

Brake characteristics

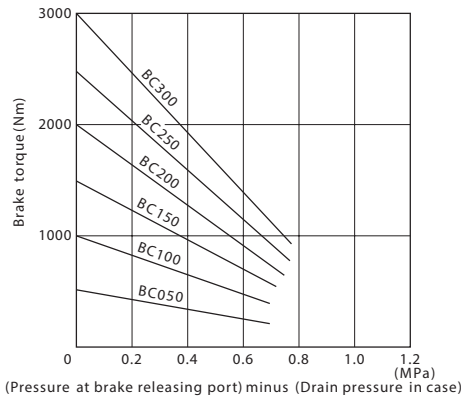

Allowable radial load

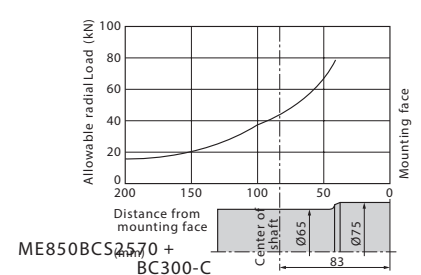
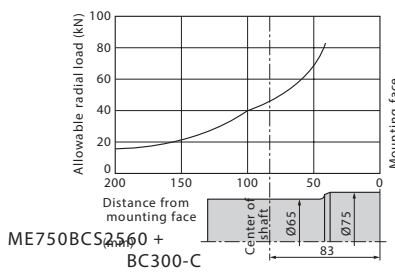

Bearing life

Direction of radial load			
ME750B			
ME850B			

The bearing life graphs show Bearing life (B-10Life) (hrs) on the y-axis (0 to 40000) versus Pressure (MPa) on the x-axis (0 to 27.5). The graphs are for N = 100rpm and F = 40kN. Three curves are shown for different bearing life specifications: 0, 10, and 20. The bearing life decreases as pressure increases.

DOWMAX with mechanical brake

MK300-FS001+BP121-C

Hydraulic motor	Displacement	304	152	cm ³ /rev
	Rated pressure	24.5 (250)		MPa (kgf/cm ²)
	Peak pressure	31.9 (325)		MPa (kgf/cm ²)
	Rated torque (theoretical)	1190 (121)	594 (61)	Nm (kgfm)
	Rated speed	600	800	rpm
	Max. speed	600	800	rpm
Mechanical brake	Static brake torque	1190 (121)		Nm (kgfm)
	Brake releasing pressure	1.2 (12)		MPa (kgf/cm ²)
	Endurable press. of brake cylinder	31.9 (325)		MPa (kgf/cm ²)
	Brake cylinder stroke volume	37		cm ³
GD ²	0.34		kgm ²	
Casing capacity	1.9		ℓ	
Mass	102		kg	

Outline dimensions

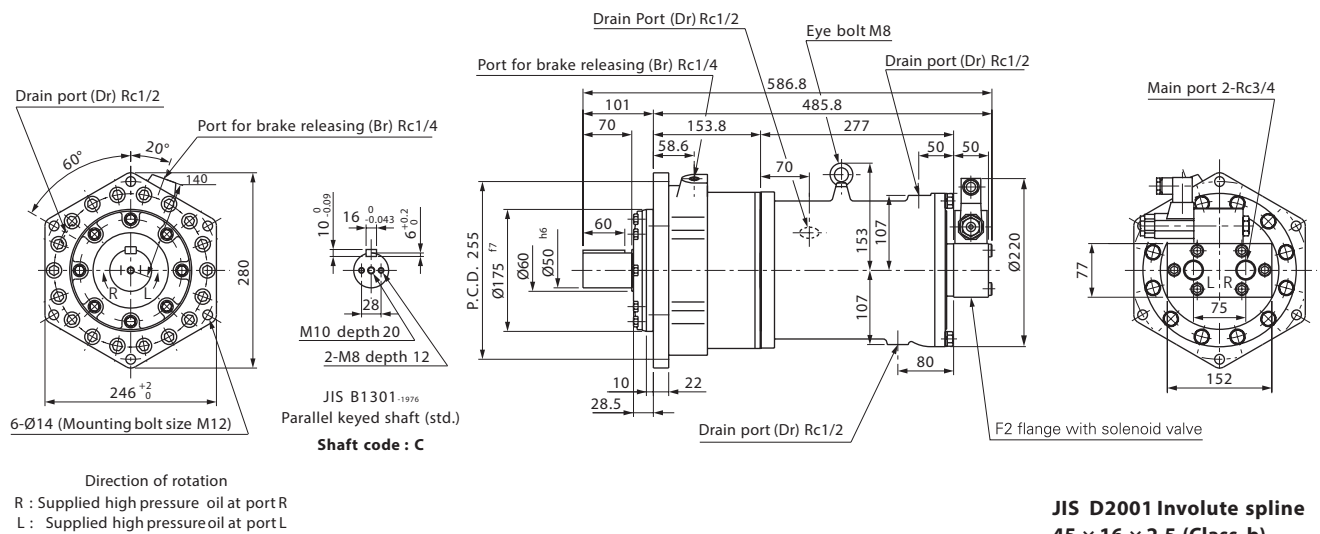

JIS D2001 Involute spline 45 × 16 × 2.5 (Class b)

Tool	Coefficient of profile shifting	+ 0.800
	Tooth form	Stub tooth
	Module	2.5
Shaft	Pressure angle	20°
	Number of teeth	16
	Grade	Class b (flank fit)
Tooth thickness	Dia. of basic pitch circle	40
	Over-pin dia.	49.277 ^{+0.018} _{-0.107} Pin dia.=Ø4.5
	Over-all across a given number of teeth (reference)	20.379 ^{+0.001} _{-0.058} (3-teeth)
	Outer dia.	44.5
	Inner dia.	39

DOWMAX with mechanical brake

Coding

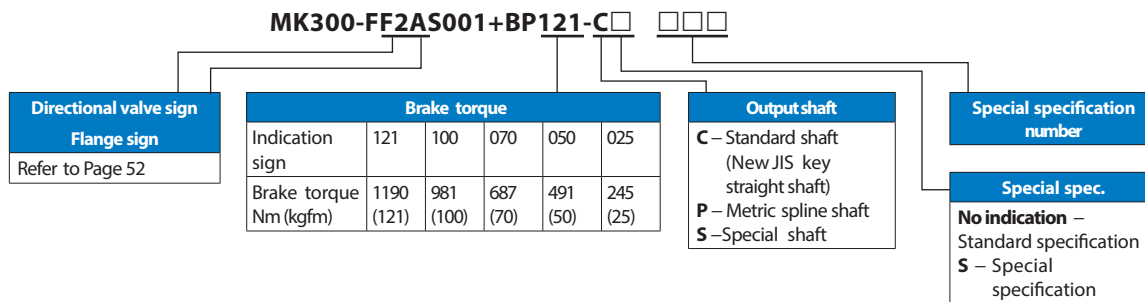

Brake characteristics

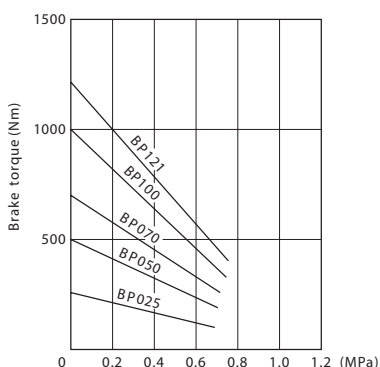

(Pressure at brake releasing port) minus (Drain pressure in case)

Allowable radial load

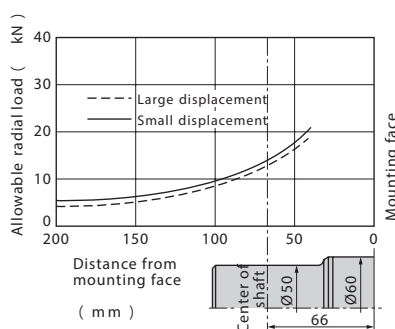

Bearing life

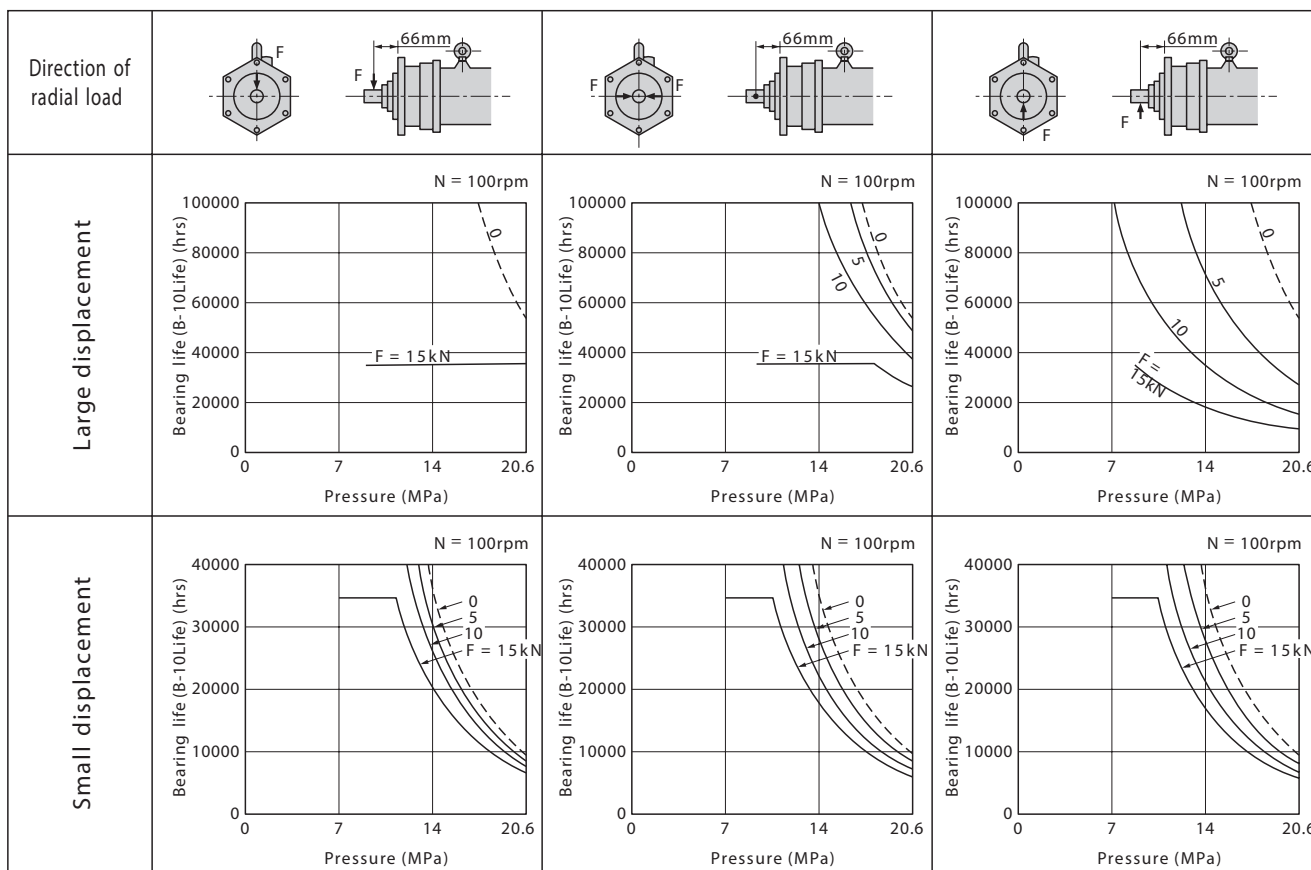

DOWMAX with mechanical brake

MK600-CS002+BR250-C

Hydraulic motor	Displacement	602	301	cm ³ /rev
	Rated pressure	24.5 (250)		MPa (kgf/cm ²)
	Peak pressure	31.9 (325)		MPa (kgf/cm ²)
	Rated torque (theoretical)	2350 (240)	1180 (120)	Nm (kgfm)
	Rated speed	300	600	rpm
	Max. speed	300	600	rpm
Mechanical brake	Static brake torque	2450 (250)		Nm (kgfm)
	Brake releasing pressure	1.2 (12)		MPa (kgf/cm ²)
	Endurable press. of brake cylinder	31.9 (325)		MPa (kgf/cm ²)
	Brake cylinder stroke volume	58		cm ³
GD ²	1.0		kgm ²	
Casing capacity	2.9		ℓ	
Mass	204		kg	

Outline dimensions

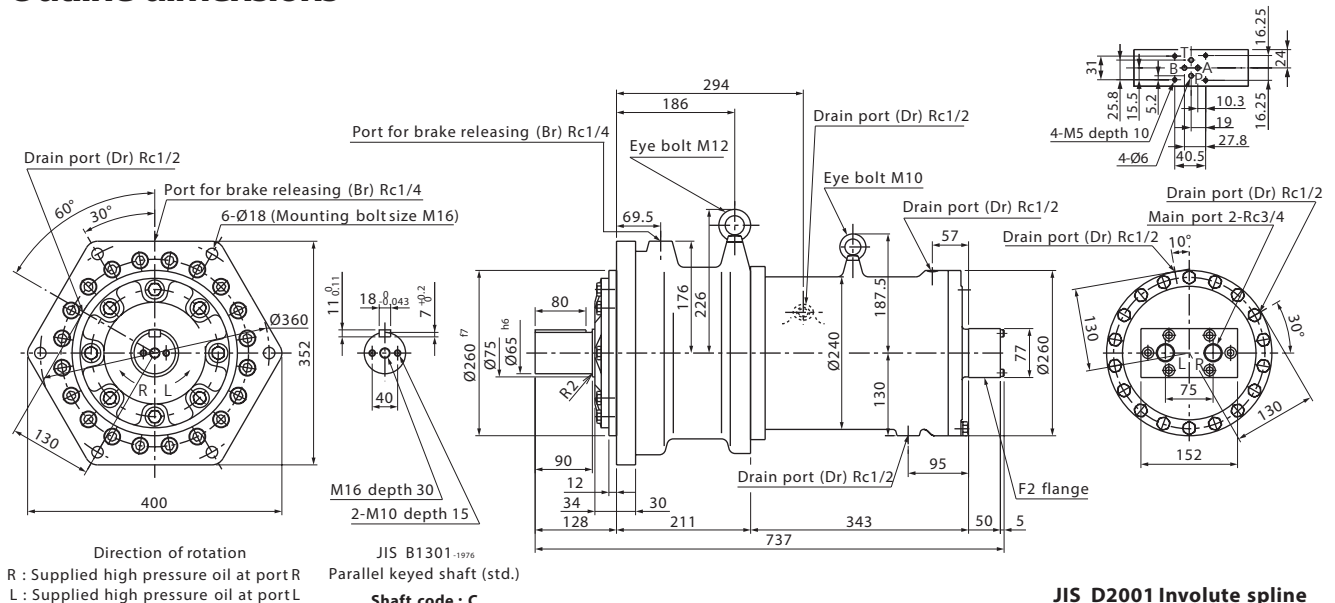

Spline shaft

Shaft code : P

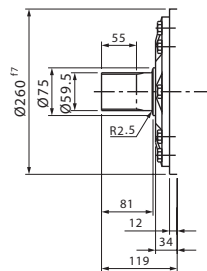
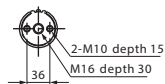

JIS D2001 Involute spline

60 × 22 × 2.5 (Class b)

Tool	Coefficient of profile shifting	+ 0.800
	Tooth form	Stub tooth
	Module	2.5
Number of teeth	Pressure angle	20°
	Number of teeth	22
Shaft thickness	Dia. of basic pitch circle	55
	Grade	Class b (flank fit)
	Over-pin dia.	64.516 ^{+0.020} _{-0.114}
Outer dia.	Pin dia.=Ø4.5	
	Over-all, across a given number of teeth (reference)	27.970 ^{+0.001} _{-0.058}
Inner dia.	(4-teeth)	
	Outer dia.	59.5
	Inner dia.	54

DOWMAX with mechanical brake

Coding

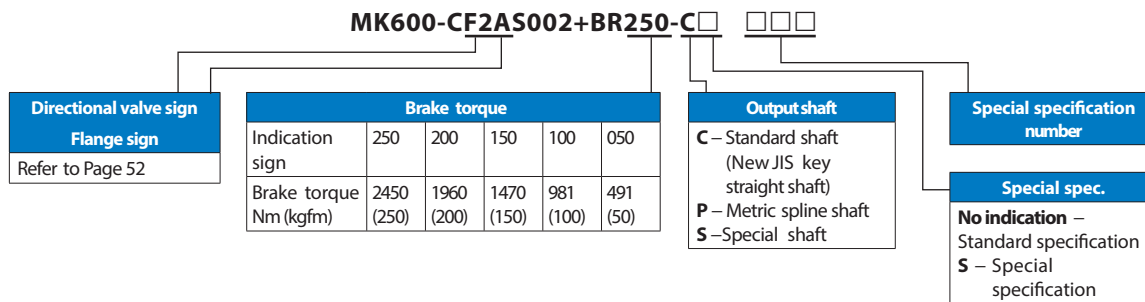

Brake characteristics

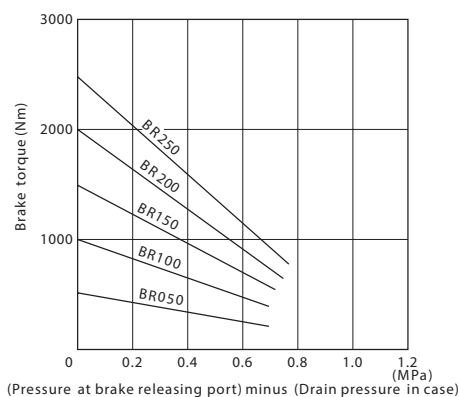

Allowable radial load

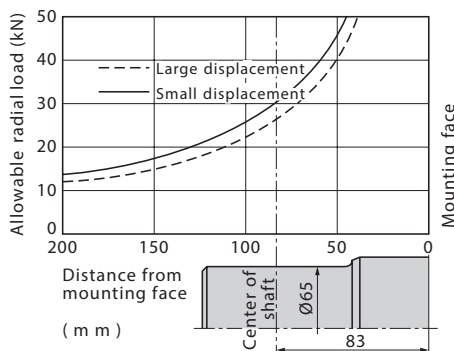

Bearing life

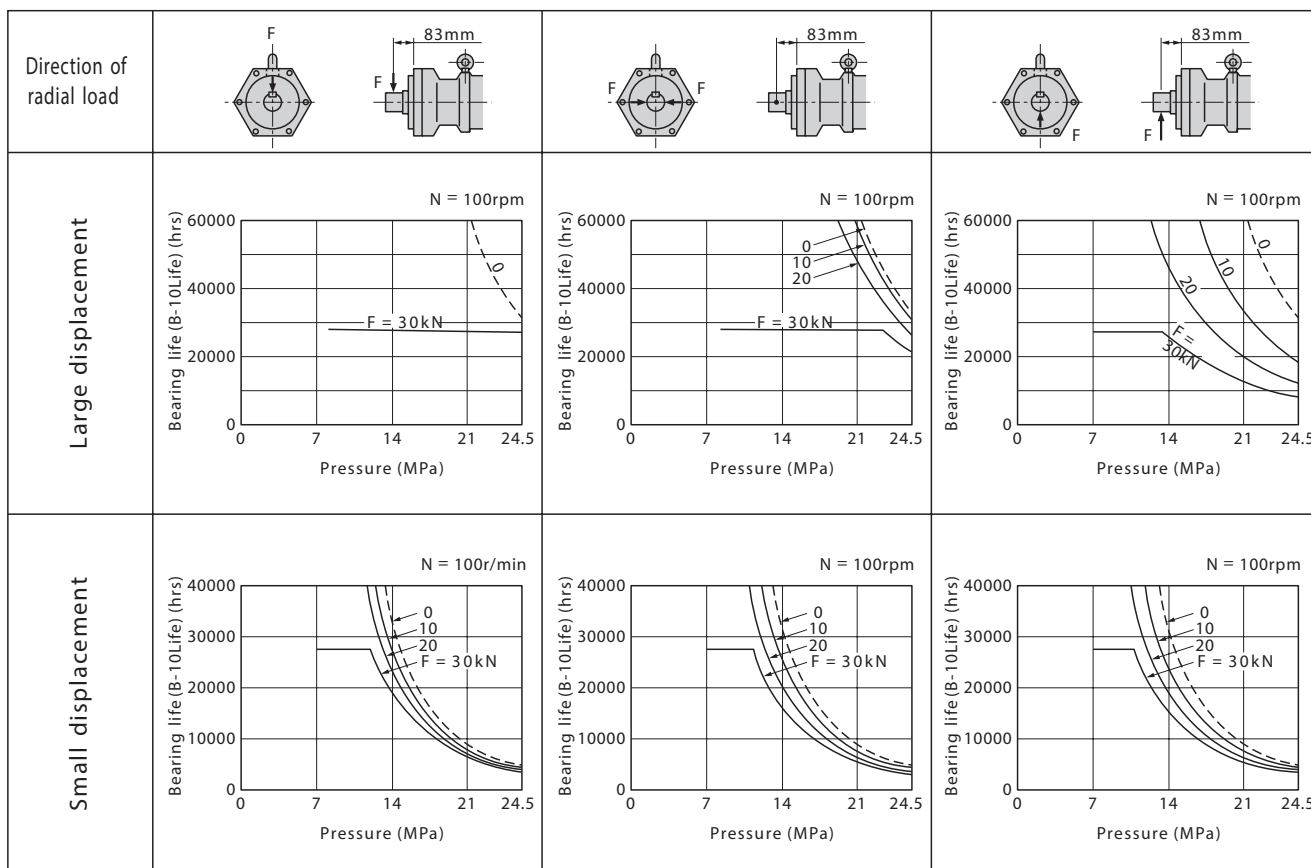

DOWMAX motor with planetary gear

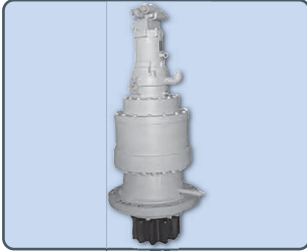
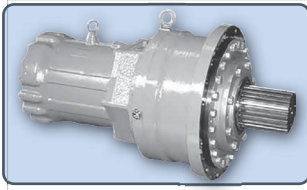

With a recent trend that a larger capacity is required for machinery like those for construction, ship/marine equipment and steel mill, a compact hydraulic motor with a larger torque capacity is much more required.

Geared motor DOWMAX (using planetary reduction gear) is developed to answer this requirement and they are already proving its merits in many fields including the shield tunneling machines, steel mill equipment.

Hydraulic motor:

DOWMAX motor- a reputable low-speed high-torque motor for its superior performance and reliability owing to the structure of the double swash plate and opposed multiple piston.



Reduction gear:

Planetary gears boast impact-resistance, superior anti-wear features, reliability for long time use and compact size, as they are manufactured with high quality material through heat treatment and high-precision gear cutting, based on the principle of an effective load distribution.

This catalog is useful for frequent use.

Note: This catalog contains planetary gear combinations which are frequently used. These motors can be made compatible for high-torque, high reduction ratio other than specified values in this catalog. We appreciate your inquiry in this regard.

Single-Stage Reduction Gear with DOWMAX motor (Reduction ratio: 5.091)

Double-Stage Reduction Gear with DOW MAX motor (Reduction ratio: 24 or 26.3)

DOW MAX motor is developed with planetary gear suitable for the application of Shield Tunneling.

All kind of DOWMAX motor (two-speed, with Mechanical Brake, with Counter Balance Valve etc.) and special motor and planetary gear reduction motor combined together are compatible.

Model no.

Hydraulic motor

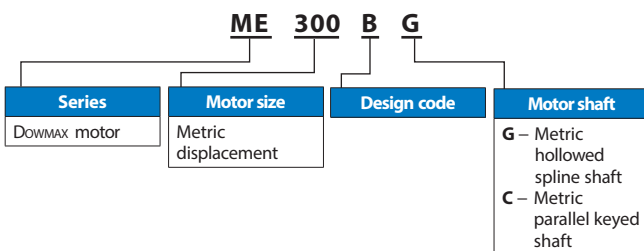

Gear reducer

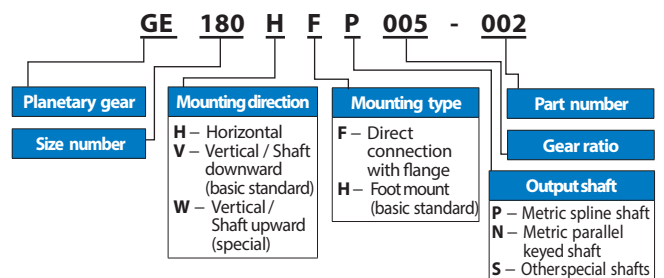

DOWMAX motor with planetary gear

Single reduction Gear ratio 5.091

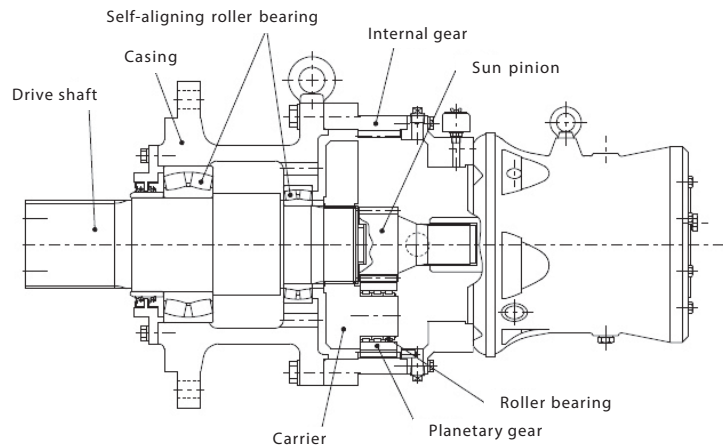

Specification

Motor model	Gear motor	Gear ratio	Equivalent displacement (cm ³ /rev)	Rated speed (rpm)	Continuous operation		Intermittent max.		Allowable radial load (N)	Mass (kg)
					Output torque (Nm)	Effective pressure (M Pa)	Output torque (Nm)	Effective pressure (M Pa)		
ME100-C	GE180HFP005-002	5.091	504	80	1025	13.7	2380	31.9	31000	107
				20	2055	27.5			37200	
				10	2055	27.5			37200	
ME150-G	GE180HFP005-004	5.091	774	80	1510	13.3	3630	31.6	31000	132
				20	3020	26.7			37200	
				10	3100	27.4			37200	
ME175-G	GE180HFP005-006	5.091	891	80	1510	11.4	3630	27.5	31000	132
				20	3020	22.9			37200	
				10	3300	25.0			37200	
ME300BG	GE224HFP005-008	5.091	1527	80	2810	12.4	6760	29.9	62000	190
				20	5630	24.9			80300	
				10	6140	27.1			80300	
ME350BG	GE250HFP005-010	5.091	1782	80	3630	13.7	8420	31.9	73000	260
				20	7260	27.5			92000	
				10	7260	27.5			92000	
ME600BG	GE280HFP005-012	5.091	3055	80	5040	11.1	12100	26.7	85000	346
				20	10080	22.3			117000	
				10	11000	24.3			117000	
ME750BG	GE315HFP005-014	5.091	3818	80	6500	11.5	18050	31.9	126000	443
				20	15560	27.5			176000	
				10	15560	27.5			176000	
ME850BG	GE315HFP005-016	5.091	4317	80	7790	12.2	18700	29.2	126000	443
				20	15580	24.3			176000	
				10	17000	26.6			176000	
ME1300AG	GE355HFP005-018	5.091	6847	60	11000	10.8	27600	27.2	223000	590
				20	23000	22.7			264000	
				10	24900	24.5			264000	
ME1900-G	GE400HFP005-020	5.091	9510	40	18100	12.8	39600	28.1	264000	870
				15	33000	23.4			338000	
				10	34500	24.5			338000	
ME2600-G	GE450HFP005-022	5.091	13125	35	30200	15.5	55200	28.4	350000	1150
				15	46000	23.6			411000	
				10	47600	24.5			411000	

- The allowable output torque differs for the output speed used.
- The intermittent max. torque shall be within the duty cycle of 1% per every time.
- Effective pressure is calculated for the rated output torque, by using following values for efficiency.
 - Mechanical efficiency of gear (Single reduction): 0.98
 - Mechanical efficiency of gear (Double reduction): 0.95
 - Torque efficiency of motor: 0.95
- The allowable radial load is at the midpoint of the standard shaft length.
- In case motor casing pressure (Drain line) comes below 0 gauge pressure even when motor is off-operation, special specification (Double oil seal) should be applied. In this case please contact us.
- For detail information for motor, please refer to catalog another page.
- In case motor are used, as its output shaft to be positioned upward or downward, special specification (Double oil seal) should be applied. In this case, please contact us.
- Please contact us if none of the above meet the specification. Special specification should be applied.

DOWMAX motor with planetary gear

Dimensions

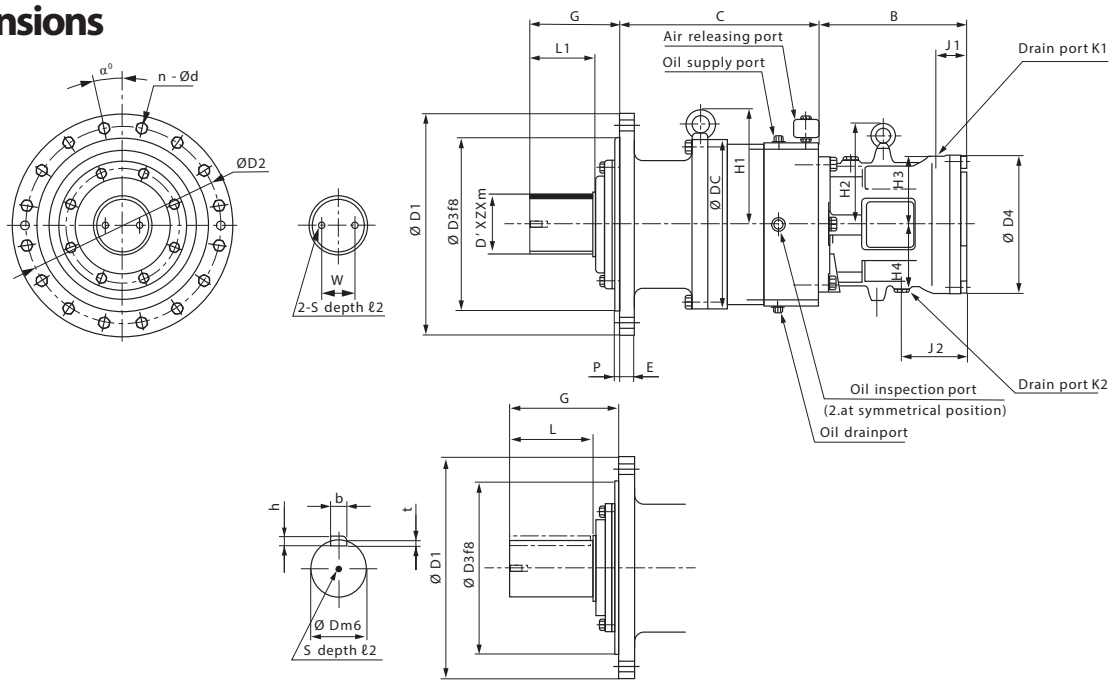

Single reduction

Involute spline shaft (Old Std. JIS D2001-1959, Side fit, Class b)

Model	D'	Z	m	L ₁	L ₂	S	W
	Dia.	No. of teeth	Module				
GE180***005	75	23	3	80	25	M12	40
GE224***005	93	29	3	120	35	M16	60
GE250***005	110	20	5	120	35	M16	70
GE280***005	120	22	5	130	35	M16	70
GE315***005	130	24	5	130	35	M16	80
GE355***005	150	28	5	145	40	M20	90
GE400***005	170	32	5	170	40	M20	100
GE450***005	200	38	5	200	50	M24	130

Parallel keyed shaft (Key Std. JIS B1301-1976, Parallel key)

Model								G
	D (m6)	b	h	t	S	L ₂	L	
GE180***005	70	20	12	7.5	M12	28	110	164
GE224***005	90	25	14	9	M12	28	140	202
GE250***005	105	28	16	10	M12	28	140	207
GE280***005	115	32	18	11	M12	28	170	223
GE315***005	125	32	18	11	M12	28	170	239
GE355***005	145	36	20	12	M16	30	210	285
GE400***005	165	40	22	13	M16	30	225	315
GE450***005	195	45	25	15	M16	30	270	358

Planetary gear

Model	C	D ₁	D ₂	D ₃ (f8)	DC	E	G	H ₁	P	d	n	α	Lub Oil (ℓ)
GE180***005	283	300	270	230	245	20	134	164	10	14	16	11.25	1.2
GE224***005	342	380	340	280	290	28	182	196	10	22	12	15	2
GE250***005	363	410	360	285	315	28	187	218	10	22	16	11.25	3
GE280***005	405	450	400	350	345	30	183	233	10	22	16	11.25	4
GE315***005	438	465	425	320	390	40	199	266	20	22	16	11.25	6
GE355***005	519	560	500	420	445	45	220	294	25	33	16	11.25	9
GE400***005	566	625	555	485	540	45	260	360	25	33	16	11.25	16
GE450***005	633	710	640	570	575	55	288	398	25	33	16	11.25	21

Note: Volume of lubrication oil shows for horizontal installation.

Hydraulic motor with hollow shaft

Model	B	D ₄	H ₂	H ₃	H ₄	J ₁	J ₂	K ₁	k ₂
ME100	196	174	—	81	—	41	—	Rc1/4	—
ME150	184	220	154	107	107	50	80	Rc1/2	Rc1/2
ME175	184	220	154	107	107	50	80	Rc1/2	Rc1/2
ME300B	261	240	171	116	111	55	174	G1/2	G1/2
ME350B	261	240	171	116	111	55	174	G1/2	G1/2
ME600B	305	280	205	137	130	64	133	G1/2	G1/2
ME750B	337	297	211.5	141.5	145.5	110	70	G1/2	G1/2
ME850B	337	297	211.5	141.5	145.5	110	70	G1/2	G1/2
ME1300A	373	335	228.5	167.5	153	72	208	Rc1/2	Rc1/2
ME1900	417	375	264	175	175	162.5	162.5	G1/2	G1/2
ME2600	482	390	280	191	191	218.2	218.2	G3/4	G3/4

DOWMAX motor with planetary gear

Double reduction Gear ratio 24 or 26.3

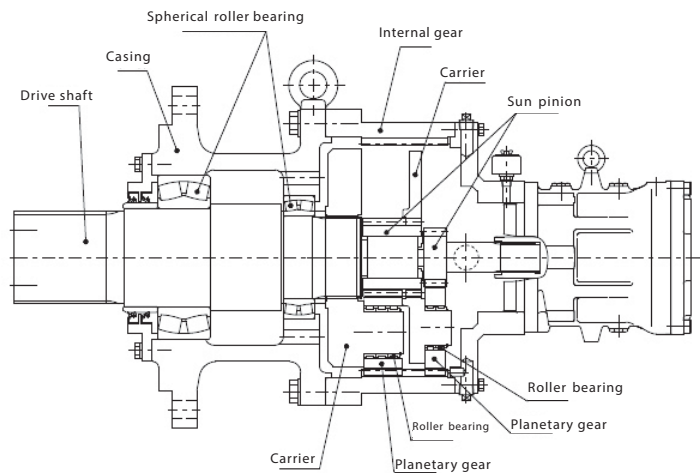

Specification

Model	Gear model	Gear ratio	Equivalent displacement (cm ³ /rev)	Rated speed (rpm)	Continuous operation		Intermittent max.		Allowable radial load (kN)	Mass (kg)
					Output torque (Nm)	Effective pressure (M Pa)	Output torque (Nm)	Effective pressure (M Pa)		
ME100-C	GE250HFP026-024	26.3	2604	38	6030	16.0	11760	31.1	92000	272
				20	9800	25.9			92000	
				10	10400	27.5			92000	
ME150-G	GE31MHFP024-026	24.0	3648	25	12700	24.0	16870	31.9	176000	392
				10	14530	27.4			176000	
				5	14530	27.4			176000	
ME175-G	GE31MHFP024-028	24.0	4200	25	14000	23.0	19400	31.8	176000	392
				10	16730	27.4			176000	
				5	16730	27.4			176000	
ME300BG	GE31MHFP024-030	24.0	7200	25	14100	13.5	26400	25.3	176000	420
				10	22000	21.0			176000	
				5	24000	23.0			176000	
ME350BG	GE31MHFP024-032	24.0	8400	25	14100	11.6	26400	21.6	176000	420
				10	22000	18.0			176000	
				5	24000	19.7			176000	
ME300BG	GE355HFP024-034	24.0	7200	25	18300	17.5	33300	31.9	264000	510
				10	28690	27.4			264000	
				5	28690	27.4			264000	
ME350BG	GE355HFP024-036	24.0	8400	25	18300	15.0	36850	30.2	264000	510
				10	30000	24.6			264000	
				5	33400	27.4			264000	
ME600BG	GE355HFP024-038	24.0	14400	25	18300	8.8	36850	17.6	264000	556
				10	30000	14.3			264000	
				5	33500	16.0			264000	
ME750BG	GE400HFP024-040	24.0	18000	21	30000	11.5	58800	22.5	320000	773
				10	47400	18.1			338000	
				5	53400	20.4			338000	
ME850BG	GE400HFP024-042	24.0	20352	18	35000	11.8	58800	19.9	338000	773
				10	47400	16.0			338000	
				5	53400	18.1			338000	
ME850BG	GE450HFP024-044	24.0	20352	18	40500	13.7	78890	26.7	411000	1023
				10	63000	21.3			411000	
				5	71700	24.3			411000	
ME1300AG	GE500HFP024-046	24.0	32280	16	56700	12.1	103290	22.0	470000	1370
				10	62300	13.3			470000	
				5	93900	20.0			470000	

- The allowable output torque differs for the output speed used.
- The Intermittent max. torque shall be within the duty cycle of 1% per every minute.
- Effective pressure is calculated for the rated output torque, by using following values for efficiency.

• Mechanical efficiency of gear:	0.96
• Torque efficiency of motor:	0.95
- The allowable radial load is at the midpoint of the standard shaft length.
- In case motor casing pressure (Drain line) comes below 0 gauge pressure even when motor is off-operation, Special specification (Double oil seal) should be applied. In this case, please contact us.
- In case motor are used, as its output shaft to be positioned upward or downward, special specification (Double oil seal) should be applied. In this case, please contact us.
- Please contact us if none of the above meet the specification. Special specification should be applied.

DOWMAX Double reduction

Dimensions

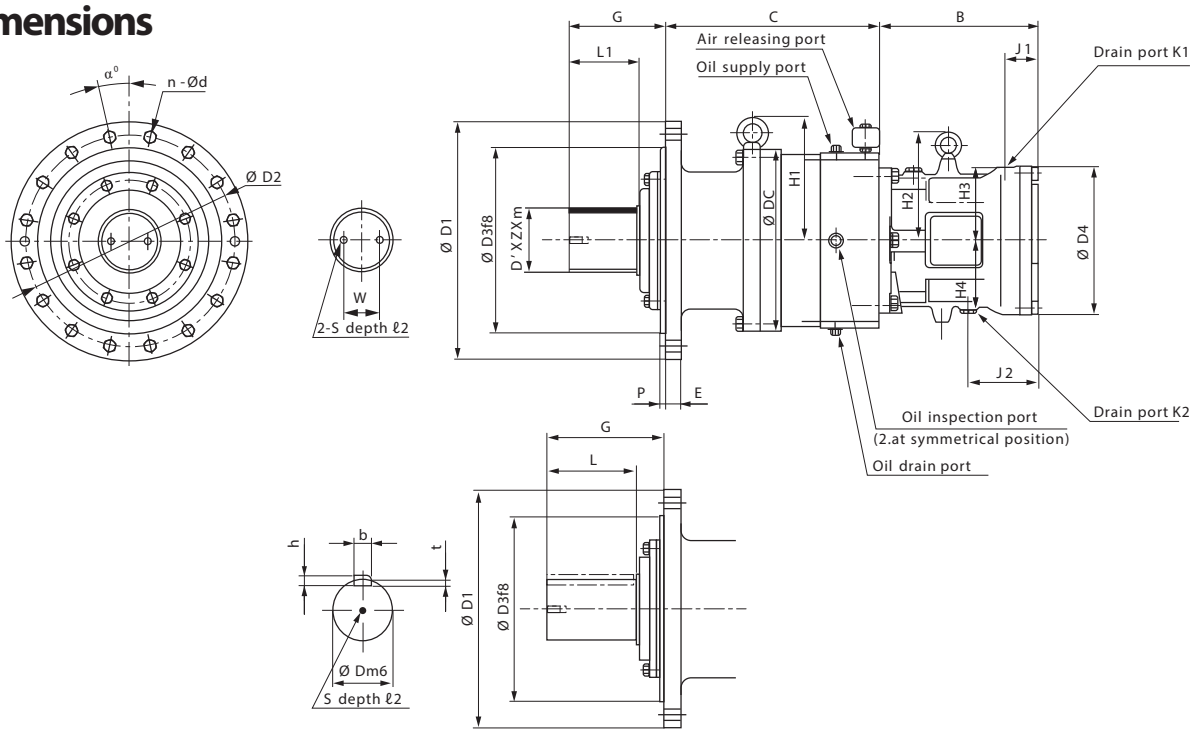

Double reduction

Involute spline shaft (Old std. JIS D2001-1959, Side fit, Class b)

Model	D'	Z	m	L ₁	L ₂	S	W
	Dia.	No. of teeth	Module				
GE250***026	110	20	5	120	35	M16	70
GE31M***024	130	24	5	130	35	M16	80
GE355***024	150	28	5	145	40	M20	90
GE400***024	170	32	5	170	40	M20	100
GE450***024	200	38	5	200	50	M24	130
GE500***024	220	27	7.5	250	50	M24	130

Parallel keyed shaft (Key std. JIS B1301-1976, Parallel key)

Model								G
	D (m6)	b	h	t	S	L ₂	L	
GE250***026	105	28	16	10	M12	28	140	207
GE31M***024	125	32	18	11	M12	28	170	239
GE355***024	145	36	20	12	M16	30	210	285
GE400***024	165	40	22	13	M16	30	225	315
GE450***024	195	45	25	15	M16	30	270	358
GE500***024	215	50	28	17	M20	35	300	408

Planetary gear

Model	C	D ₁	D ₂	D ₃ (f8)	DC	E	G	H ₁	P	d	n	α	Lub Oil (ℓ)
GE250***026	412	410	360	285	315	28	187	218	10	22	16	11.25	4
GE31M***024	499	465	425	320	400	40	199	271	20	22	16	11.25	7
GE355***024	589	560	500	420	445	45	220	294	25	33	16	11.25	10
GE400***024	643	625	555	485	540	45	260	360	25	33	16	11.25	18
GE450***024	723	710	640	570	575	55	288	398	25	33	16	11.25	23
GE500***024	782	780	690	600	640	60	358	452	25	39	16	11.25	30

Note: Volume of lubrication oil shows for horizontal installation.

Hydraulic motor with hollow shaft

Model	B	D ₄	H ₂	H ₃	H ₄	J ₁	J ₂	K ₁	k ₂
ME100	196	174	-	81	-	41	-	Rc1/4	-
ME150	184	220	154	107	107	50	80	Rc1/2	Rc1/2
ME175	184	220	154	107	107	50	80	Rc1/2	Rc1/2
ME300B	261	240	171	116	111	55	174	G1/2	G1/2
ME350B	261	240	171	116	111	55	174	G1/2	G1/2
ME600B	305	280	205	137	130	64	133	G1/2	G1/2
ME750B	337	297	211.5	141.5	145.5	110	70	G1/2	G1/2
ME850B	337	297	211.5	141.5	145.5	110	70	G1/2	G1/2
ME1300A	373	335	228.5	167.5	153	72	208	Rc1/2	Rc1/2

DOWMAX motor with planetary gear

Shield tunneling application

DOWMAX motors with planetary gear reduction are widely used in shield tunneling application due to outstanding durability and high efficiency.

- High performance resultGood result in all Shield Tunneling Operation.
- High pressure application Rated pressure 20.6 MPa, Max. pressure 24.5 MPa
- Compact.....Compact and light weight due to special DOWMAX shape.
- Outstanding durability.....DOWMAX and planetary gear has sufficient durability for Shield Tunneling Operation
- Smooth operationEven at full power DOWMAX with Planetary Gear can be run smooth and noise free.
- Smooth operation even at low-speed..... With excellent performance at Low-Speed and Positioning performance DOWMAX can be used as Electors also.

Specification

Model	Gear ratio	Equivalent displacement cm ³ /rev	Rated pressure MPa (kgf/cm ²)	Max. pressure MPa (kgf/cm ²)	Rated torque Nm (kgfm)	Max. torque Nm (kgfm)	Rated speed (rpm)	Allowable radial load (kN)	Radial load point (Distance from mounting surface) (mm)	Mass kg
ME150-G + GE280HFP031-184	1/31.03	4717	20.6 (210)	24.5 (250)	14710(1500)	17652(1800)	20	160	128	252
ME1300AG+GEN18HFP006-185	1/6	8070	20.6 (210)	24.5 (250)	25125(2562)	29910(3050)	15	250	142.5	500

- Rated output torque and peak output torque is 95% of efficiency
- For the service life refer other catalog in conjunction with this catalog as life varies with different models. Rated speed is suitable for the rated pressure. In case of low pressure used continuously, there are other models also suitable for application according to use. Please inquire for any further requirement.
- This catalog is exclusively for Shield Cutter Drive. Therefore useful for Horizontal use only. In case of requirement of shaft in Upward or Downward direction please inquire as it becomes special specification.
- In case Dowmax motors of this series are required to be used for the operation other than cutter and that of Shield Tunneling please discuss with us.
- Dowmax motor with Planetary Gear can also be built with other reduction ratio as well as torque specification than those mentioned in the catalog. We appreciate your inquiry for these models.

Selection chart

This chart indicates the relation of actual torque and shaft rotation at the rated pressure of 20.6MPa. Given the required torque and shaft speed the appropriate model can be selected from the diagram. When the operating pressure differs from 20.6MPa, refer to the performance data for the respective model.

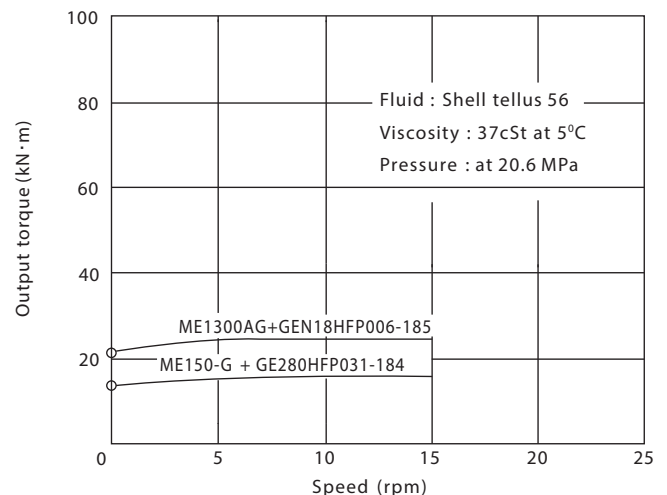

DOWMAX Shield tunneling application

ME150-G+GE280HFP031-184

Gear Parts No.: DY2184B

Equivalent displacement	4,717cm ³ /rev
Gear ratio	1/31.03
Output torque	14,710Nm
Max. output torque	17,652Nm
Rated speed	20rpm

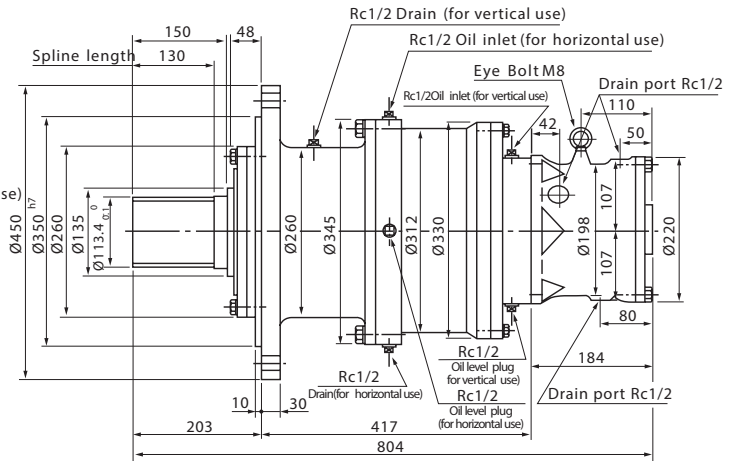
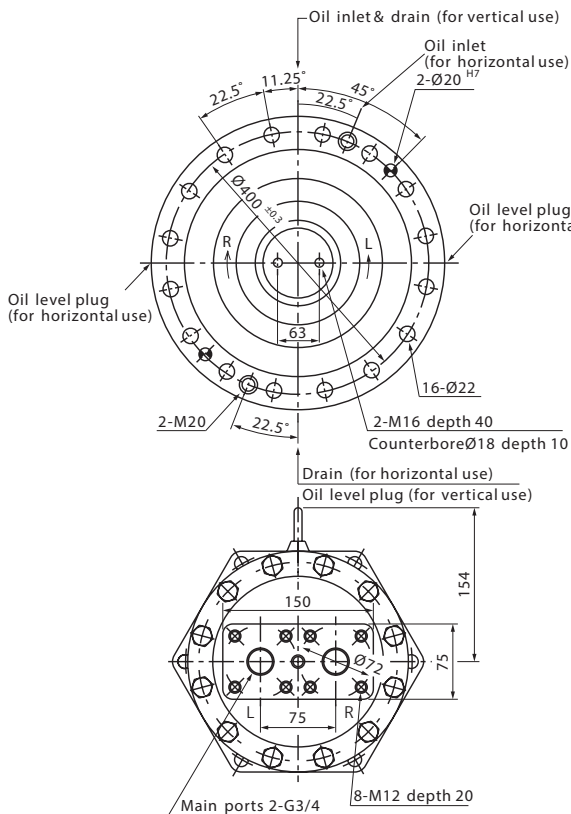

Rotation (viewed shaft end)
 CW : Port R pressurized
 CCW : Port L pressurized

JIS D2001 Involute spline

114 × 36 × 3 (Class b)	
Coefficient of profile shifting + 0.800	
Tool	Tooth form Stub Tooth
	Module 3
	Pressure angle 20°
Number of teeth 36	
Dia. of basic pitch circle 108	
Tooth thickness	Grade Class b
	Over-pin Dia. 119.827 ^{-0.027} _{-0.154}
	Pin Dia.=Ø5.40
Overall across a given number of teeth (reference) 43.008 ^{-0.004} _{-0.071} (5-Teeth)	
JIS D-2001-1959	
Tooth Flank Fit	

Bearing life

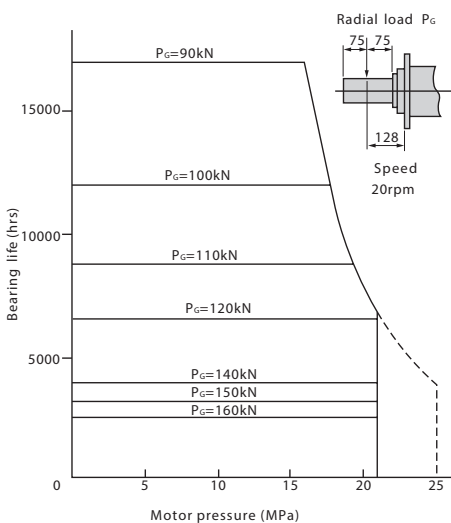

1. Radial load

The load applied radially on the midpoint of the shaft extension should be less than the value indicated below:

Pressure MPa	20.6
Radial load kN	160

2. Bearing life

The gear box bearing life will vary as shown on the chart depending on the radial load imposed on the output shaft. The chart indicates the bearing life (B-10 Life) when the output speed is 20 rpm with the varied pressures and the radial load magnitudes. When the output speed is other than 20 rpm, it is obtained by the following formula:

$$\text{B-10 Life} = (\text{Bearing life obtainable on the chart}) \times \frac{20}{\text{Output speed}}$$

The bearing life, when the load point is not at the middle of shaft extension, is different from the chart. Refer to factory in such a case.

3. Lubrication

Quantity of lubricating oil	4L for horizontal use
Lubricating oil	Mild EP gear oil equivalent to ISO VG220 (ambient temp.) 0~35°C

4. For detailed information for motor, please refer to other page.

DOWMAX motor with planetary gear

ME1300AG+GEN18HFP006-185

Gear Parts No.: DY2185B

Equivalent displacement	8,070cm ³ /rev
Gear ratio	1/6
Output torque	25,125Nm
Max. output torque	29,910Nm
Rated speed	15rpm

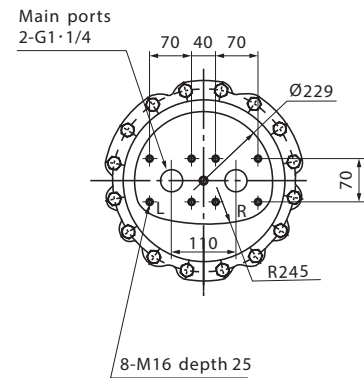
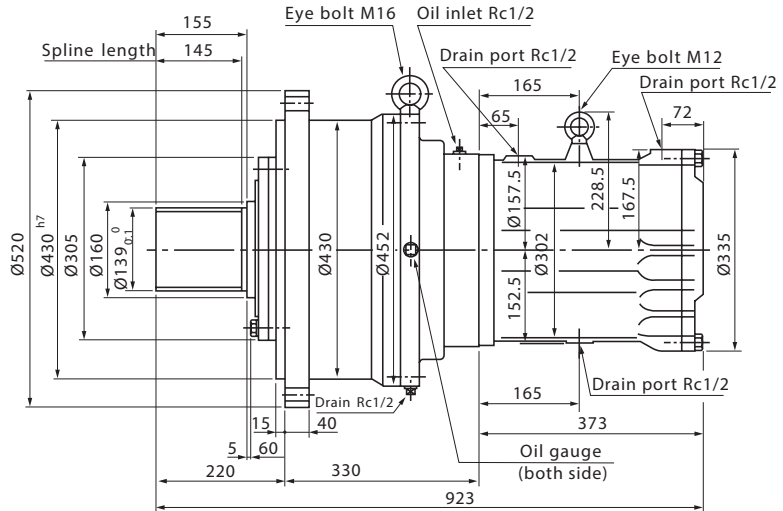
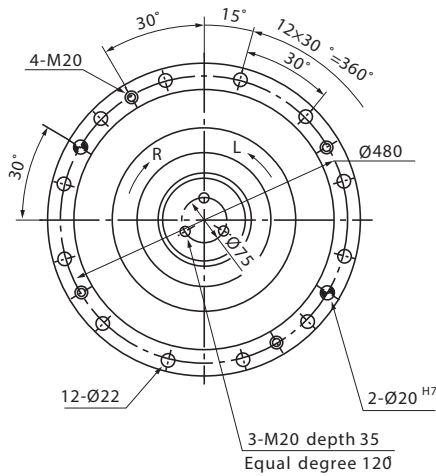

Rotation (viewed shaft end)
 CW : Port R pressurized
 CCW : Port L pressurized

JIS D2001 Involute spline

140 × 26 × 5 (Class b)		
Coefficient of profile shifting	+ 0.800	
Tool	Tooth form	Stub tooth
	Module	5
	Pressure angle	20°
Number of teeth	26	
Dia. of basic pitch circle	130	
Tooth thickness	Grade	CLASS b
	Over-pin Dia.	149.272 ^{-0.033} - 0.175
	Pin dia.=Ø9	56.219 ^{-0.005} - 0.086 (4-teeth)
JIS D-2001-1959		
Tooth flank fit		

Bearing life

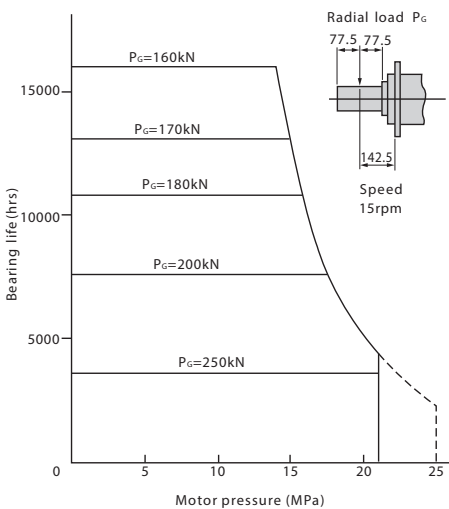

1. Radial load
 The load applied radially on the midpoint of the shaft extension should be less than the value indicated below:

Pressure MPa	20.6
Radial load kN	250

2. Bearing life
 The gear box bearing life will vary as shown on the chart depending on the radial load imposed on the output shaft. The chart indicates the bearing life (B-10 Life) when the output speed is 15 rpm with the varied pressures and the radial load magnitudes. When the output speed is other than 15 rpm, it is obtained by the following formula:

$$\text{B-10 Life} = (\text{Bearing life obtainable on the chart}) \times \frac{15}{\text{Output speed}}$$

The bearing life, when the load point is not at the middle of shaft extension, is different from the chart. Refer to factory in such a case.

3. Lubrication

Quantity of lubricating oil	6L for horizontal use
Lubricating oil	Mild EP gear oil equivalent to ISO VG220 (ambient temp.) 0~35°C

4. For detailed information for motor, please refer to other page.

DOWMAX Counterbalance valve with brake valves

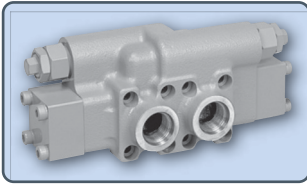

This counter balance valve generates the braking pressure in the hydraulic motor, proportional to the load in lowering loads at slewing, running and winching operations and thus prevent overrunning of motor forced by loads.

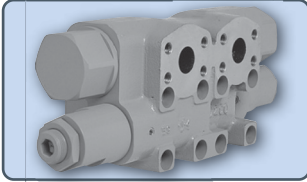

In addition, the counter balance valve contains housed brake valves to protect the hydraulic motor from overloads as well as smooth acceleration and deceleration of load.

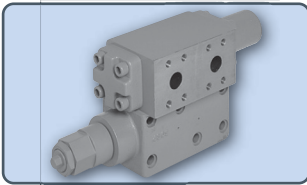
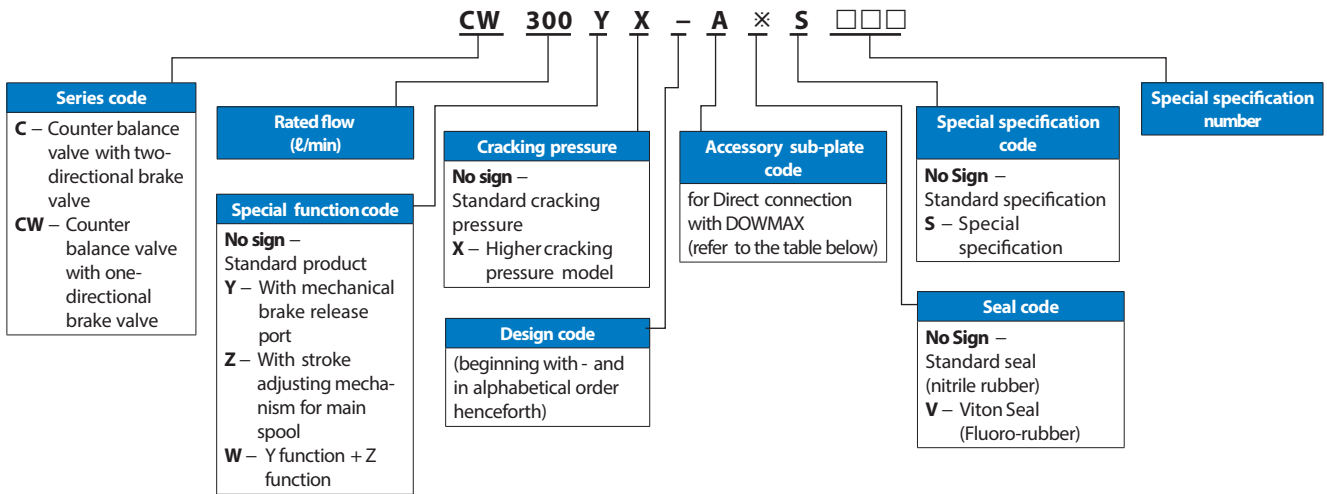

Table of contents

Specification, model code	85
Operation principle.....	86
C100 □	87
C300 □ B	89
CW300 A	91

Counter balance valve with brake valves

Model code



Specification

Model	Rated flow (l/min)	Adjustable range of relief valve pressure MPa (kgf/cm ²)	Mass (kg)	Characteristics
C100	100	9.8~27.5 (100~280)	7	Allows smooth acceleration/deceleration at slewing, running and winching operations.
C100Y				To be used for hydraulic motors with mechanical brake, an automatic brake release ports is provided.
C100Z				To be used for devices at low flow rate and greater load changes, and matching with machines to be easily adjusted from outside.
C100W				Both Y and Z functions above are combined.
C300B	300		19	Allows smooth acceleration/deceleration at slewing, running and winching operations.
C300YB				To be used for hydraulic motors with mechanical brake, an automatic brake release ports is provided.
C300ZB				To be used for devices at low flow rate and greater load changes, and matching with machines to be easily adjusted from outside.
C300WB				Both Y and Z functions above are combined.
CW300A	300	24	This one-directional counter balance valve is used for winches allowing smooth rolling down operation.	

- Operating oil temperature range : -20° to +80° C.
- Operating oil viscosity range : 15 to 500cSt (optimum viscosity range : 25 to 100cSt)

* Accessory sub-plate code for direct connection with DOW MAX

Applicable DOW MAX Model	ME100	ME150 ME175 ME300B ME350B	ME600B	ME750 B ME850B	ME1300A	ME1900	ME260 0	ME3100	ME4100
C100□	-	A	N	C	R	G	H	K	J
C300□B		A	A	C	R	G	H	K	J
CW300A		A	A	C	R	G	H	K	J

(Models marked - can be directly connected without a sub-plate. However, a sub-plate code for direct connection in ME100+ C100Y & C100W is NM.)

Counter balance valve with brake valves

Operation principle

1. Two-directional counter balance valves, C100,C300B

(During acceleration)

When the directional valve is switched to either direction to accelerate the hydraulic motor, assuming that the valve is switched to the (a) side, the fluid will be introduced to the A_v port. Then, the fluid is directed to the spring chamber A_s at the edge surface of the main spool through the pilot passage A_p of the counter balance valve and thus, the main spool will move to the right direction. Then, the fluid flow into the A_v port is introduced to the hydraulic motor from the A_M port through the check valve in the main spool. As the hydraulic motor cannot absorb all the fluid flow into the A_v port until acceleration has been completed, the fluid pressure will rise up to the relief valve set pressure and the excessive fluid is discharged to the return line from the relief valve R_a .

(During neutral brake)

When the directional valve is returned to the neutral position, the pressure of A_v and B_v become equivalent, reaching the tank pressure and thus the main spool of the counter balance valve will be pushed back to the neutral position by the spring force. As the return line is closed by the check valve in the main spool, the pressure at the return side will be raised up to the relief valve set pressure and the hydraulic brake is applied to the motor to stop rotation.

(Prevention of overrun)

When the hydraulic motor is going to overrun exceeding the pump discharge volume due to external loads, the pressure at the inflow side decreases and the main spool will return to the neutral position. Thus the brake is applied to the hydraulic motor and overrun is prevented.

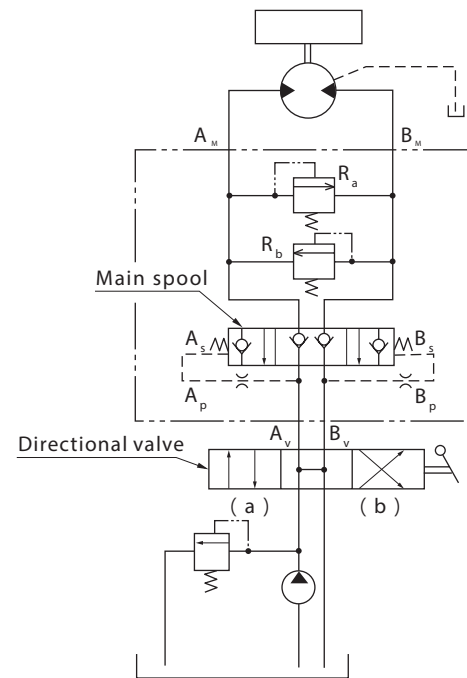

2. One-directional counter balance valves CW300A

(During rolling up)

When the directional valve is switched to the (a) side and the fluid is introduced from the A_v port, the fluid will be directed to the hydraulic motor inlet from A_M port through the check valve in the counter balance valve, and the load will be raised.

The fluid drained from the hydraulic motor outlet will be discharged to the B_v port through B_M port.

(During rolling down)

When the directional valve is switched to the (b) side, the fluid will be flown into the B_v port. The fluid introduced to the B_v port is directed to the main spool end surface through the pilot passage B_p . If the pilot pressure becomes higher than the spool spring force, the main spool will move to the left and the return side passage will be opened. The fluid flow into the B_v port is introduced to the hydraulic motor inlet through the B_M port and the load is lowered. The fluid discharged from the hydraulic motor outlet is drained to the A_v port through the A_M port. When the load is going to overrun exceeding the pump discharge volume due to gravity, the pressure at the inflow side of the motor is reduced and the pilot pressure decreases. Thus, the main spool is returned to the right side by the spring force and the return line is closed, which generates the pressure at the outlet side of the hydraulic motor and overrun is prevented.

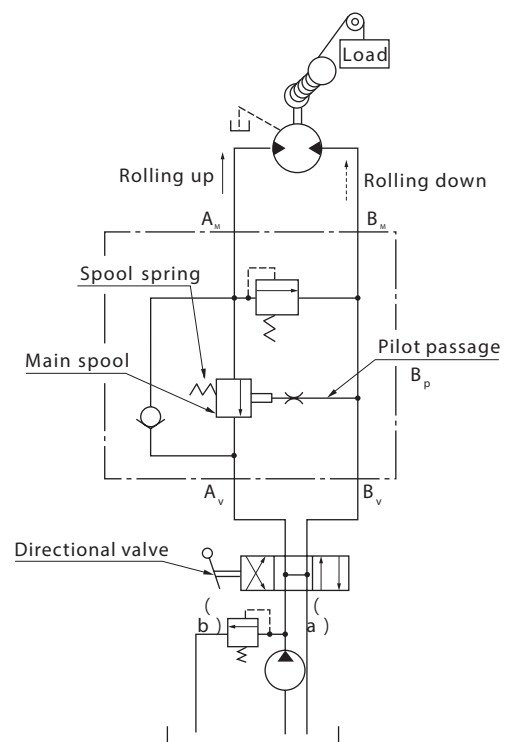

Counter balance valve with brake valves

C100

Rated flow	100 ℓ/min
Adjusting range of relief valve set pressure	9.8~27.5MPa (100~280kgf/cm ²)
Main spool cracking pressure	0.57MPa (5.8kgf/cm ²)
(Higher cracking pressure model)	1.31MPa (13.4kgf/cm ²)
Check valve cracking pressure	0.015MPa (0.15kgf/cm ²)
Mass	7kg

C100

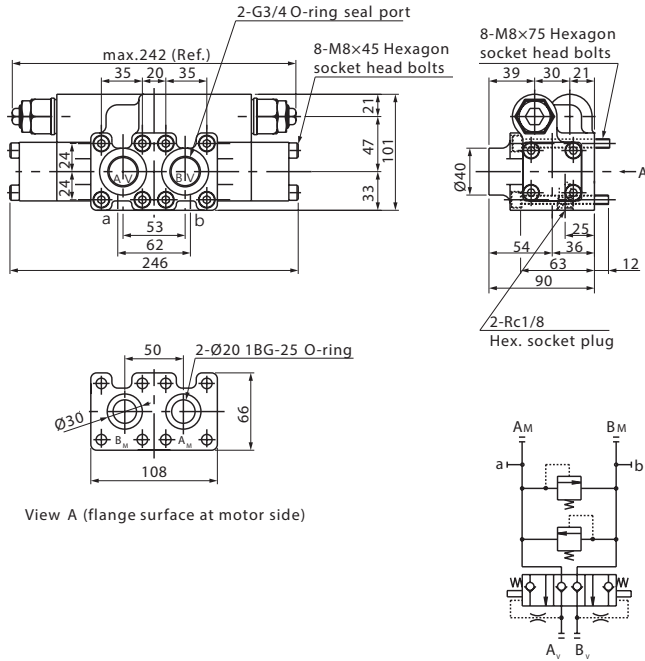

C100Y

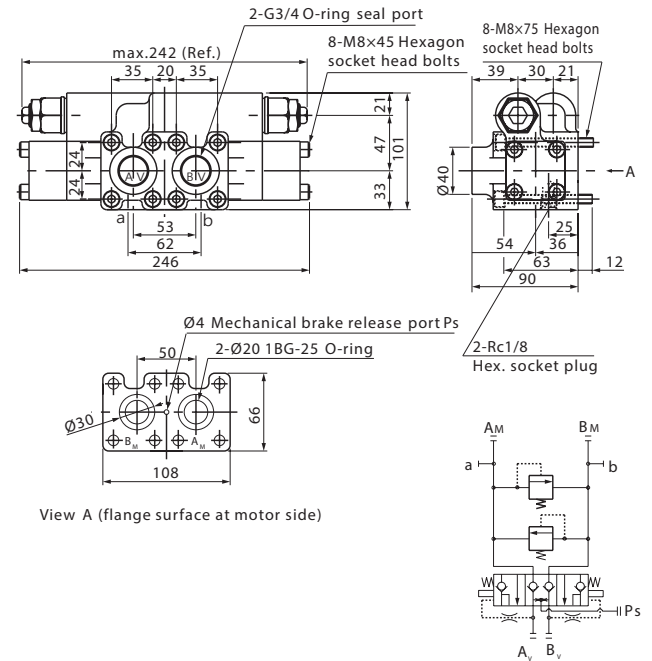

C100Z

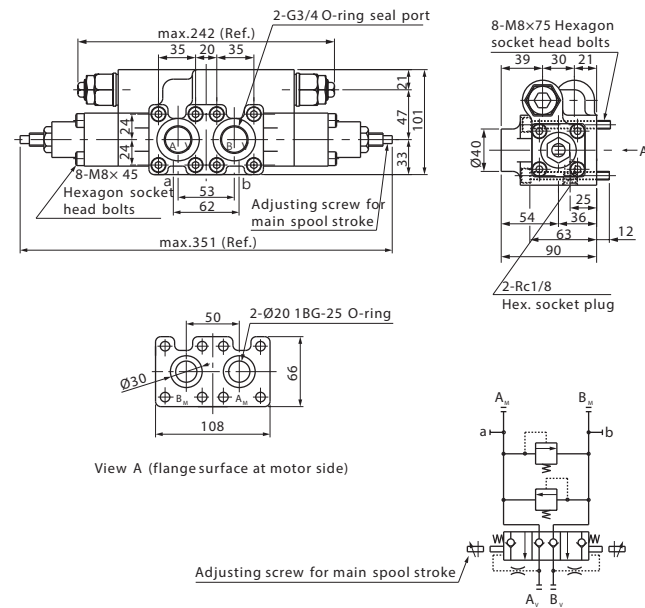

C100W

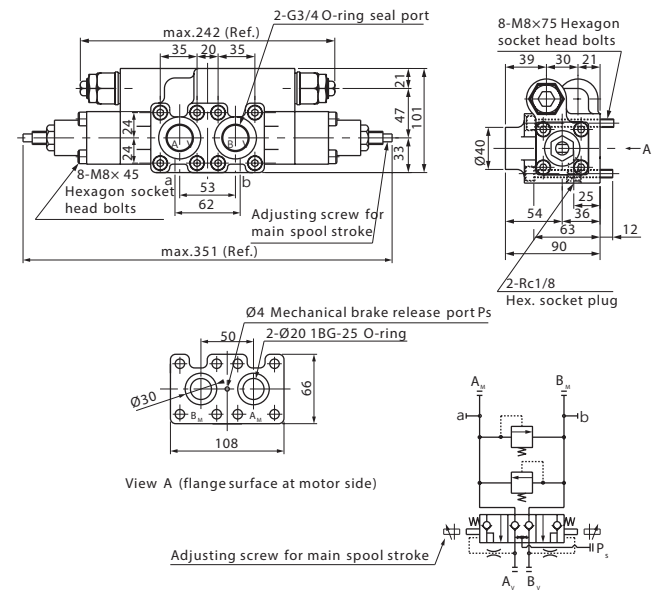

Counter balance valve with brake valves

Standard performance data

Hydraulic fluid: Shell tellus #56, viscosity: 37 cSt (Oil temperature 50° C.)

(Data are not guaranteed values but averages)

1. Pressure override performance

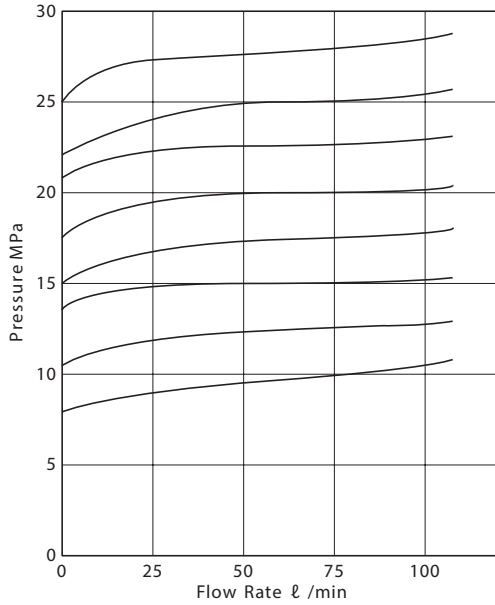

2. Pressure drop

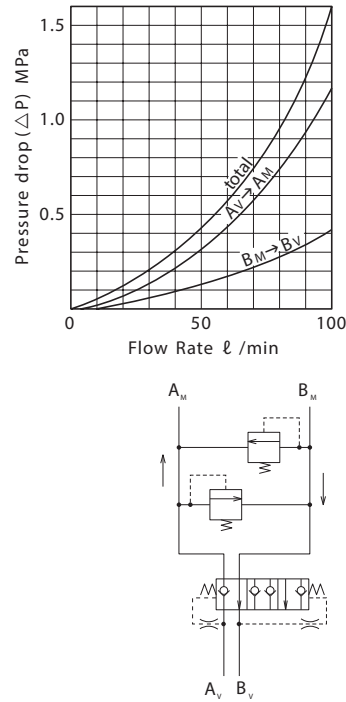

Application example

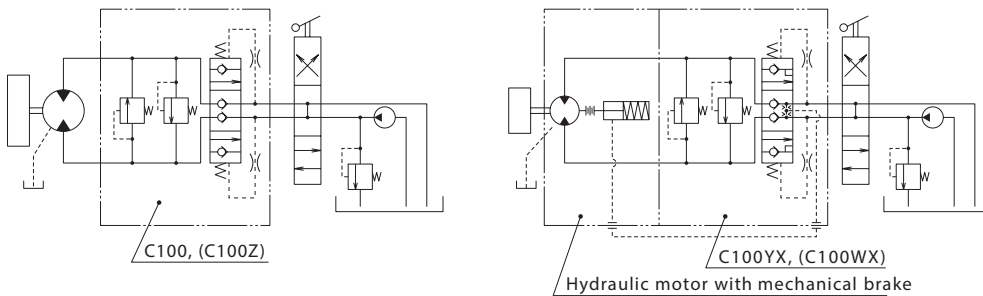

Sub-plate dimension for DOWMAX hydraulic motor direct connection

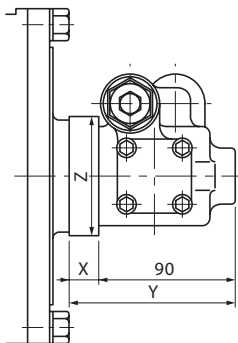

Motor Model	ME100	ME150 ME175 ME300B ME350B	ME600B	ME750 B ME850B	ME1300A	ME1900	ME2600	ME3100	ME4100
Subplate code	– (M)	A	N	C	R	G	H	K	J
X	– (20)	40	40	40	30	40	50	50	50
Y	90 (110)	130	130	130	120	130	140	140	140
Z	– (80)	80	80	82	110	100	120	120	115

Numbers in () for ME 100 show sub-plate dimensions in direct connection with C100Y & C100W. ME100 with-mark can be directly connected without sub-plate.

Counter balance valve with brake valves

C300□B

Rated flow	300 ℓ/min
Adjusting range of relief valve set pressure	9.8~27.5MPa (100~280kgf/cm ²)
Main spool cracking pressure	0.59MPa (6.0kgf/cm ²)
(Higher cracking pressure model)	1.18MPa (12kgf/cm ²)
Check valve cracking pressure	0.015MPa (0.15kgf/cm ²)
Mass	19kg

■C300B

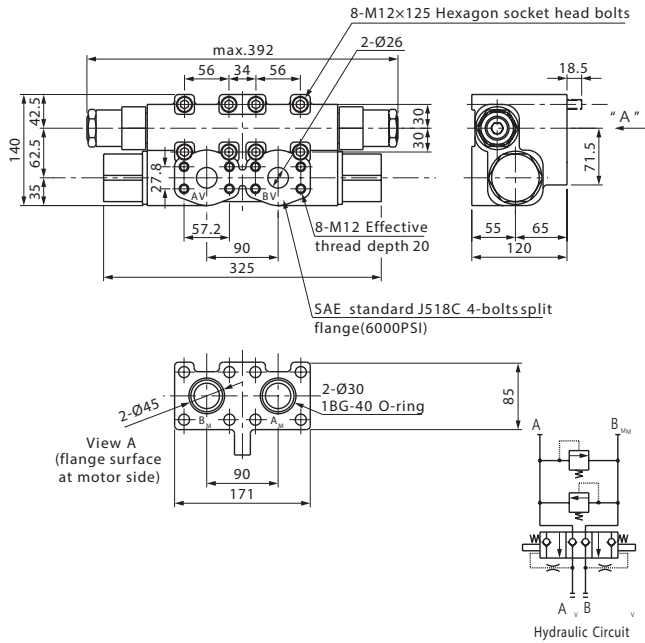

■C300YB

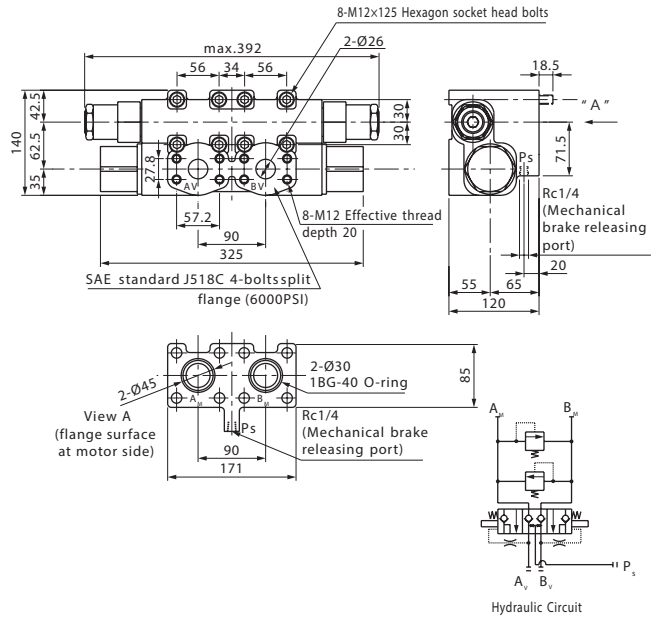

■C300ZB

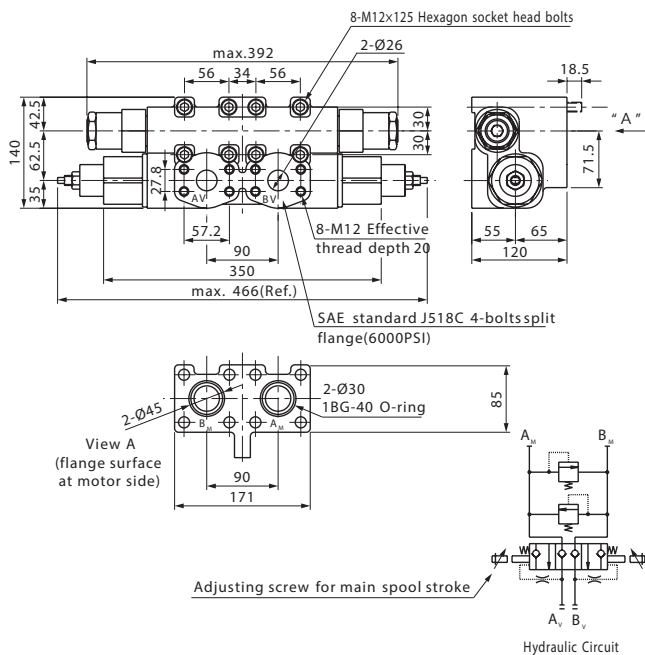

■C300WB

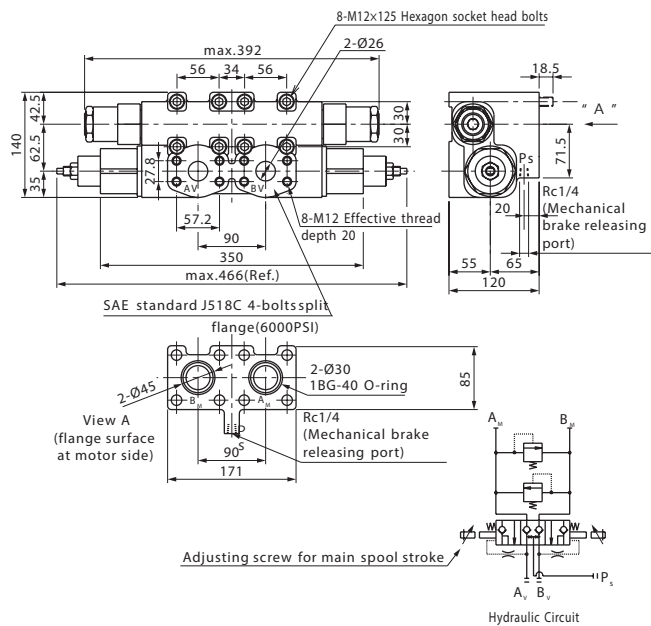

Counter balance valve with brake valves

Standard performance data

Hydraulic fluid: Shell tellus #56, viscosity: 37 cSt (Oil temperature 50° C.)

(Data are not guaranteed values but averages)

1. Pressure override performance

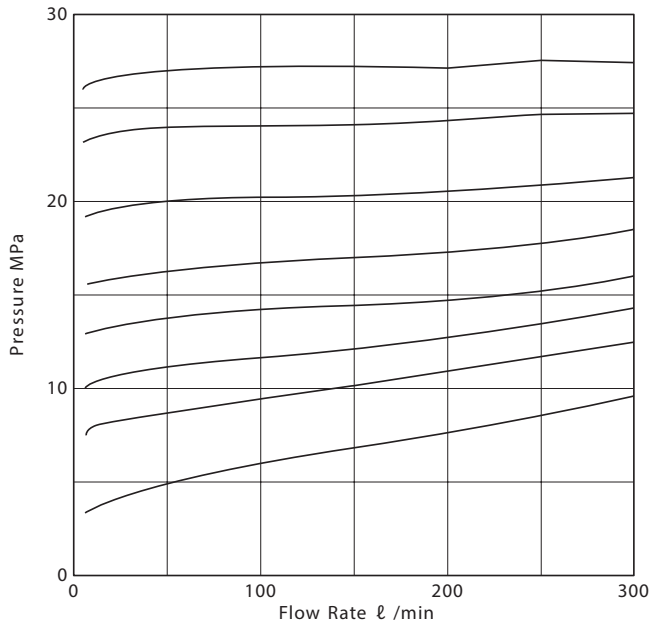

2. Pressure drop

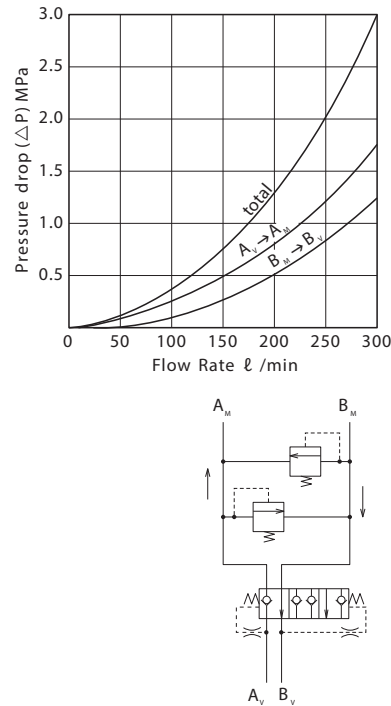

Application example

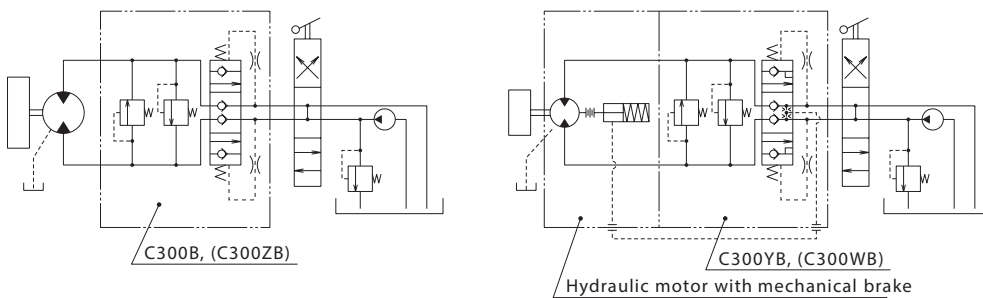

Sub-plate dimension for DOWMAX hydraulic motordirect connection

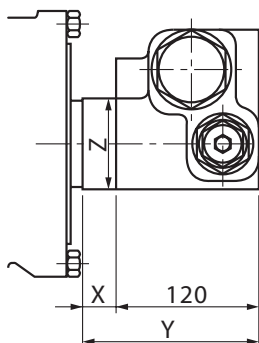

Motor Model	ME100	ME150 ME175 ME300B ME350B	ME600B	ME750 B ME850B	ME1300A	ME1900	ME2600	ME3100	ME4100
Subplate code		A	A	C	R	G	H	K	J
X		30	30	30	40	55	35	40	35
Y		150	150	150	160	175	155	160	155
Z		86	86	88	110	84	84	120	110

Counter balance valve with brake valves

CW300A

Rated flow	300 ℓ/min
Adjusting range of relief valve set pressure	9.8~27.5MPa (100~280kgf/cm ²)
Main spool cracking pressure	0.87MPa (8.9kgf/cm ²)
(Higher cracking pressure model)	1.37MPa (14kgf/cm ²)
Check valve cracking pressure	0.69MPa (7.0kgf/cm ²)
Mass	24kg

Outline dimensions and circuit diagram

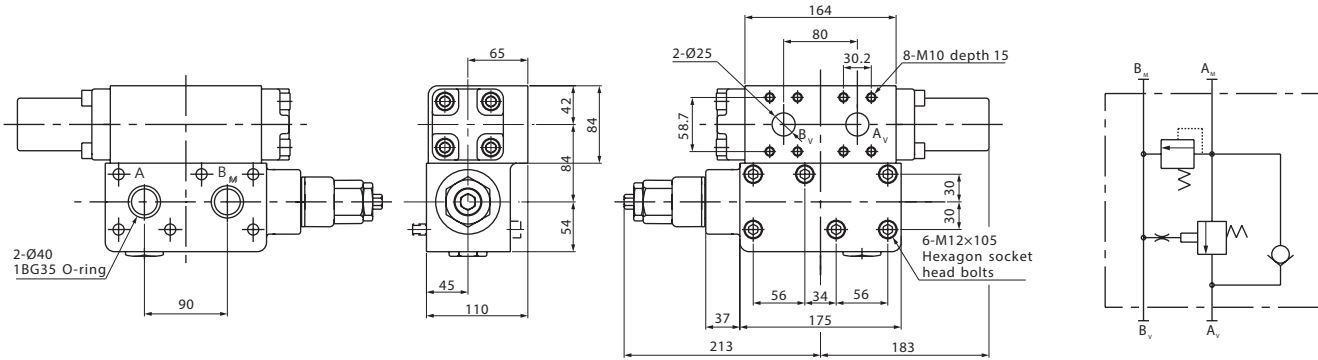

Counter balance valve with brake valves

Standard performance data

Hydraulic fluid: Shell tellus #56, viscosity: 37 cSt (Oil temperature 50° C.)

(Data are not guaranteed values but averages)

1. Pressure override performance

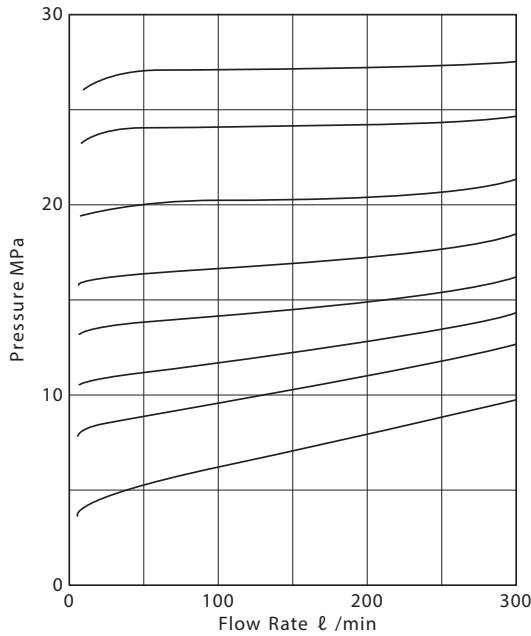

2. Pressure drop

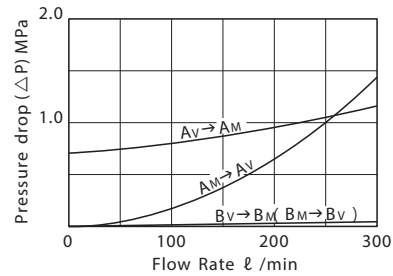

Application example

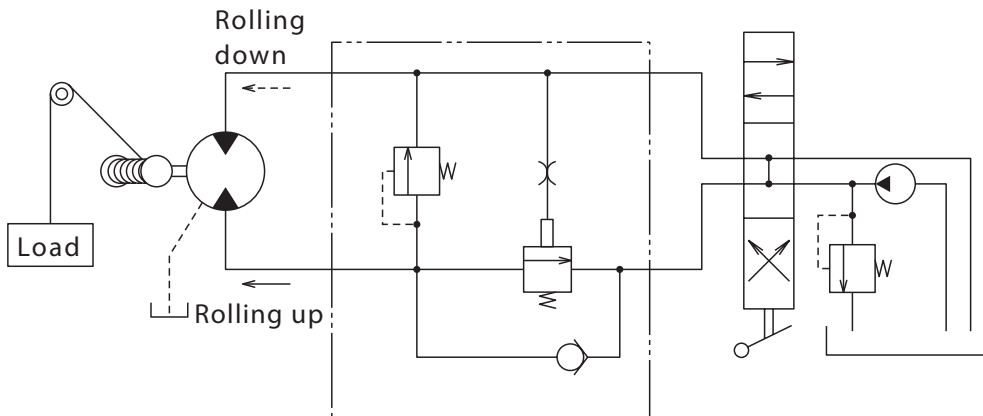

Sub-plate dimension for DOWMAX hydraulic motordirect connection

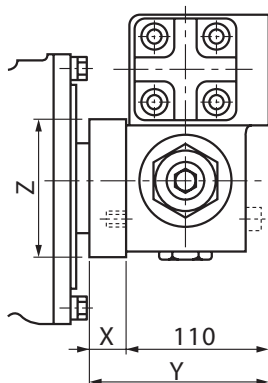

Motor Model	ME100	ME150 ME175 ME300B ME350B	ME600B	ME750 B ME850B	ME1300A	ME1900	ME2600	ME3100	ME4100
Subplate code		A	A	C	R	G	H	K	J
X		30	30	30	40	55	35	40	35
Y		140	140	140	150	165	145	150	145
Z		86	86	88	110	84	84	120	110

Danfoss Power Solutions is a global manufacturer and supplier of high-quality hydraulic and electric components. We specialize in providing state-of-the-art technology and solutions that excel in the harsh operating conditions of the mobile off-highway and industrial markets as well as the marine sector. Building on our extensive applications expertise, we work closely with you to ensure exceptional performance for a broad range of applications. We help customers around the world speed up system development, reduce costs and bring vehicles, machines and vessels to market faster.

Danfoss Power Solutions – your strongest partner in mobile hydraulics and mobile electrification.

Go to www.danfoss.com for further product information.

We offer you expert worldwide support for ensuring the best possible solutions for outstanding performance. And with an extensive network of Global Service Partners, we also provide you with comprehensive global service for all of our components.

For support inquiries send email to: industrialpumpsmotorsupport@danfoss.com

Products we offer:

- Clutches and brakes
- Cylinders (hydraulic, pneumatic)
- Electric converters and machines
- Electronic controls (HMI, controllers, sensors, telematic gateways)
- Fluid conveyance (hose, tubing, fittings, connectors)
- Hydraulic power units
- Motors (hydrostatic, low-speed high-torque, gear, electric, high speed hydraulic)
- Pumps (Hydrostatic, gear, digital displacement, industrial, mobile)
- Software and tools
- Steering (components and systems, control units, torque generators)
- Valves and actuators (hydraulic mobile valves, industrial valves, screw-in cartridge)

Local address:

**Danfoss
Power Solutions (US) Company**
2800 East 13th Street
Ames, IA 50010, USA
Phone: +1 515 239 6000

**Danfoss
Power Solutions GmbH & Co. OHG**
Krokamp 35
D-24539 Neumünster, Germany
Phone: +49 4321 871 0

**Danfoss
Power Solutions ApS**
Nordborgvej 81
DK-6430 Nordborg, Denmark
Phone: +45 7488 2222

**Danfoss
Power Solutions Trading
(Shanghai) Co., Ltd.**
Building #22, No. 1000 Jin Hai Rd
Jin Qiao, Pudong New District
Shanghai, China 201206
Phone: +86 21 2080 6201