

## Data Sheet

# H1 160cc Bent Axis Variable Motor with Counterbalance Valve DN32A

For more than 40 years, Danfoss has been developing state-of-the-art components and systems for mobile machinery used in off-highway operations around the world.

The component system of H1 bent axis variable motors with counterbalance valves enables travel drives in open circuit, which are prevented by the valve against overspeeding or cavitation in the driveline.

The H1 motors with valve assemblies bring modular design and enables a smooth and comfortable slow down of the drive shaft independently from the application needs (e.g. in a work function as well as propel drive). Start up testing with approval is necessary before these valves can be used to ensure optimal performance.

The system motor and valve package is designed for quality and reliability, and offers expanded functionality in open circuit and easy installation.

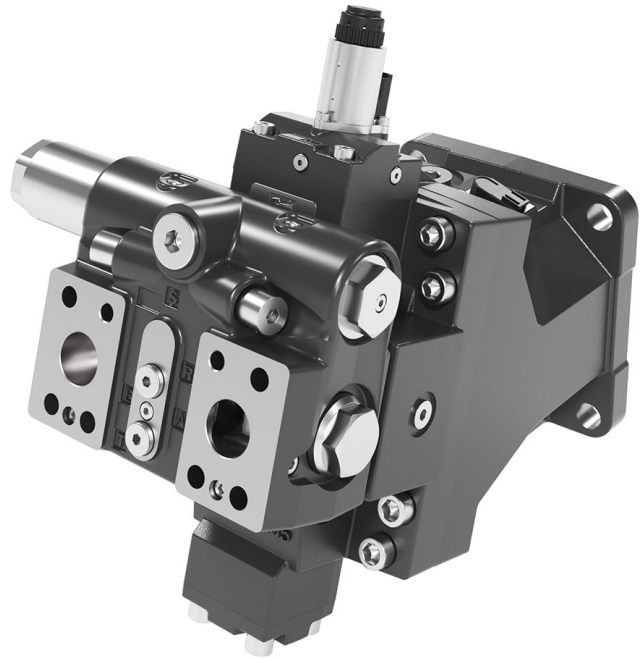

## Features

### Designed for quality and reliability

- Proven H1B reliability bringing full functionality into open circuit (10 bar min low pressure side)
- Separate brake release port supplies 21 +7 bar brake pressure
- Separate flushing options

### Expanded functionality

- Integrated high pressure relief valves for peak reduction
- External feeding port for preventing cavitation

### Wide range of controls

- Electric two-position control
- Electric proportional control
- Hydraulic two-position control
- Hydraulic proportional control
- Pressure compensator override

### Installation and packaging

- Component system allows one-piece installation

---

Comprehensive technical literature is online at [www.danfoss.com](http://www.danfoss.com)

---

**Technical specifications**

<b>Weight</b>	SAE ISO 3019/1	61.9 kg + 15 kg (motor + CBV) [136.5 lbs + 33.1 lbs]
	DIN ISO 3019/2	59.3 kg + 15 kg [130.7 lbs + 33.1 lbs]
	Cartridge	54.7 kg + 15 kg [120.6 lbs + 33.1 lbs]
<b>System</b>	Operating pressure	350 bar [5076 psi]
	Maximum operating pressure	420 bar [6092 psi]
	Nominal flow	400 l/min [106 US gal/min]
<b>Case pressure</b>	Rated	3 bar [44 psi]
	Maximum	5 bar [73 psi]
	Minimum	0.3 bar [4 psi]

*Schematic with closed center spool*

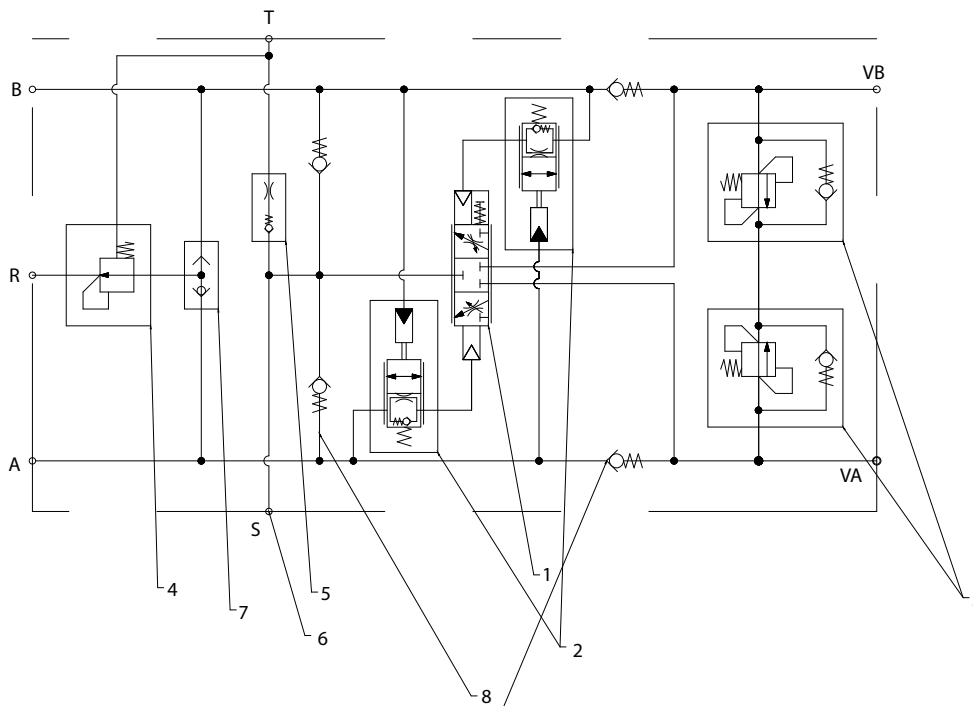

- 1. Main spool**  
(open and closed — in modelcode selectable)
- 2. Damping**  
(damped opening and damped closing with different sizes as options)
- 3. Relief valves**  
(pressure range selectable)
- 4. Brake release (port R)** (optional: system or reduced pressure)
- 5. Flushing (port T)**
- 6. Prefilling / charge / suction (port S)**
- 7. Double-check valve**

Other configurations are available. Please see the *Counterbalance Valve for Bent Axis Motors Technical Information* document (literature number BC428678672746) for more information.

**Dimensions**

*SAE ISO 3019/1 with two-position control (de-energized = max. displacement)*

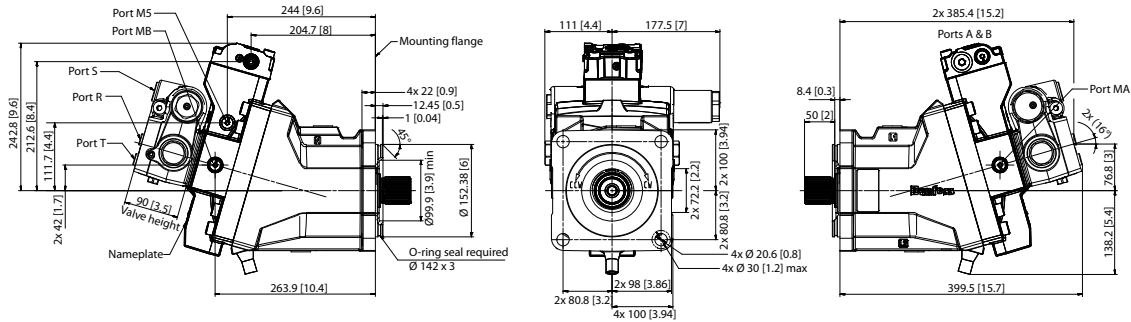

*DIN ISO 3019/2 with two-position control (de-energized = max. displacement)*

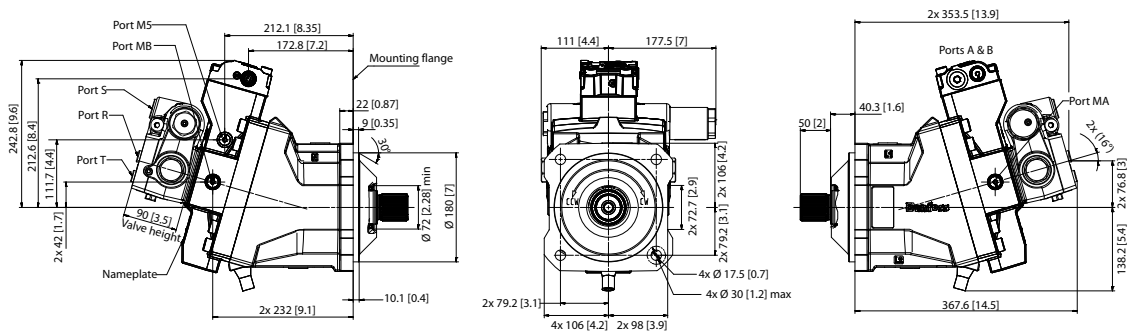

*Cartridge with hydraulic two-position Control (de-energized = max. displacement)*

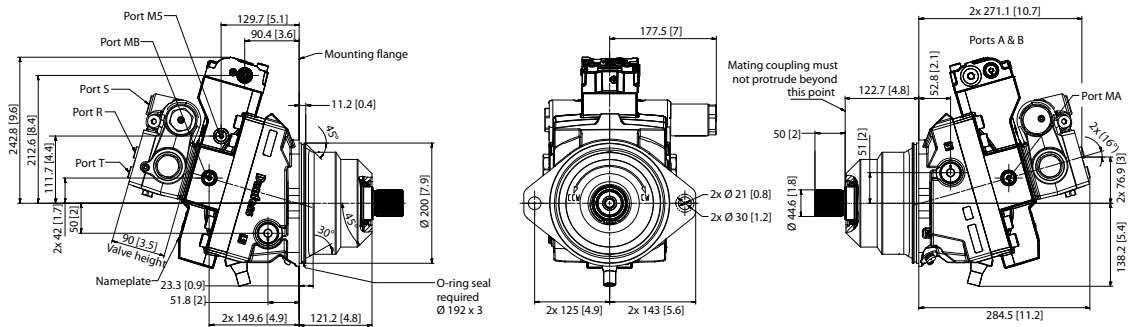

Other configurations available upon request.

**Port information**

Port	Description
A / B	System port
MA	System B gauge port: ISO 6149-1 M14 x 1.5 - 6H
MB	System A gauge port: ISO 6149-1 M14 x 1.5 - 6H
M4 / M5	Servo pressure gauge port: ISO 111926-1, 9/16 - 18 UNF - 2B
T	Flushing port: ISO 9974-1 M14 x 1.5
R	Break release port: ISO 9974-1 M14 x 1.5
S	Suction port: ISO 9974-1 M27 x 1.5
VA / VB	Motor to valve connection

Danfoss can accept no responsibility for possible errors in catalogues, brochures and other printed material. Danfoss reserves the right to alter its products without notice. This also applies to products already on order provided that such alterations can be made without subsequent changes being necessary in specifications already agreed. All trademarks in this material are property of the respective companies. Danfoss and the Danfoss logotype are trademarks of Danfoss A/S. All rights reserved.