



# Installation Guide

## VLT<sup>®</sup> CANopen MCA 105

VLT<sup>®</sup> AutomationDrive FC 301/302





## Contents

<b>1 Introduction</b>	<b>2</b>
1.1 Purpose of the Manual	2
1.2 Additional Resources	2
1.3 Product Overview	2
1.4 Approvals and Certifications	2
1.5 Disposal	3
1.6 Symbols, Abbreviations, and Conventions	3
<b>2 Safety</b>	<b>4</b>
2.1 Safety Symbols	4
2.2 Qualified Personnel	4
2.3 Safety Precautions	4
<b>3 Installation</b>	<b>6</b>
3.1 Safety Instructions	6
3.2 EMC-compliant Installation	6
3.3 Grounding	6
3.4 Cable Routing	6
3.5 Mounting	7
3.6 Setting Address Switches	8
3.7 Electrical Installation	8
3.8 Reassembling Cover	10
3.9 Applying Power	10
3.10 Checking Network Cabling	10
<b>4 Troubleshooting</b>	<b>11</b>
4.1 Warnings and Alarms	11
4.2 Troubleshooting	11
4.2.1 LED Status	11
4.2.2 No Communication with the Frequency Converter	11
<b>Index</b>	<b>12</b>

## 1 Introduction

### 1.1 Purpose of the Manual

This installation guide provides information for quick installation of a VLT® CANopen MCA 105 interface in the VLT® frequency converter.

The installation guide is intended for use by qualified personnel. Users are assumed to be familiar with the VLT® frequency converter, with CANopen technology, and with the PC or PLC that is used as a master in the system. Read the instructions before installation and ensure that instructions for safe installation are observed.

VLT® is a registered trademark.

### 1.2 Additional Resources

Resources available for the frequency converters and optional equipment:

- The *VLT® AutomationDrive FC 301/FC 302 Operating Instructions* provide the necessary information for getting the frequency converter up and running.
- The *VLT® AutomationDrive FC 301/FC 302 Design Guide* provides detailed information about capabilities and functionality to design motor control systems.
- The *VLT® AutomationDrive FC 301/FC 302 Programming Guide* provides greater detail on working with parameters and many application examples.
- The *VLT® CANopen MCA 105 Installation Guide* provides information about installing the CANopen and troubleshooting.
- The *VLT® CANopen MCA 105 Programming Guide* provides information about configuring the system, controlling the frequency converter, parameter access, programming, troubleshooting, as well as some typical application examples.

Supplementary publications and manuals are available from Danfoss. See [vlt-drives.danfoss.com/Support/Technical-Documentation/](http://vlt-drives.danfoss.com/Support/Technical-Documentation/) for listings.

### 1.3 Product Overview

#### 1.3.1 Intended Use

This installation guide relates to the CANopen interface. Ordering numbers:

- 130B1103 (uncoated)
- 130B1205 (coated)

CANopen is a low-level network that standardises only communications between industrial devices (sensors, limit switches, motor controls) and high-level devices (controllers). Configure CANopen systems to operate in a master-slave or in a distributed control architecture using peer-to-peer communication.

The CANopen interface is designed to communicate with any master abiding by the CANopen standard.

VLT® CANopen MCA 105 is intended for use with VLT® AutomationDrive FC 301/FC 302.

#### 1.3.2 Items Supplied

When the fieldbus option is not factory mounted, the following items are supplied:

- Fieldbus option and connector.
- LCP cradle.
- Front covers (in various sizes).
- Stickers.
- Accessories bag (including EMC bracket).
- Installation guide.

### 1.4 Approvals and Certifications



More approvals and certifications are available. For more information, contact a Danfoss local partner.

### 1.5 Disposal

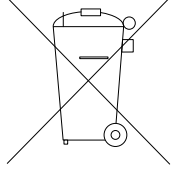

Do not dispose of equipment containing electrical components together with domestic waste.  
Collect it separately in accordance with local and currently valid legislation.

### 1.6 Symbols, Abbreviations, and Conventions

Abbreviation	Definition
CAN	Controller area network
CiA	CAN in automation
COB	Communication object
COB-ID	Communication object identifier
CTW	Control word
EDS	Electronic data sheet
EMC	Electromagnetic compatibility
EMCY	Emergency message
I/O	Input/output
LCP	Local control panel
LED	Light emitting diode
LSB	Least significant bit
MAV	Main actual value (actual output)
MRV	Main reference value
MSB	Most significant bit
NMT	Network management
N/A	Not applicable
OD	Object directory
PCD	Process data
PDO	Process data object
PLC	Programmable logic controller
PNU	Parameter number
RPDO	Receive process data object
RPM	Revolutions per minute; unit for the speed of a revolving motor
RTR	Remote transmission request frame
RX	Receive data
STW	Status word
SDO	Service data object
SYNC	Object for synchronisation of process data
TPDO	Transmit process data object
TX	Transmit data

Table 1.1 Symbols and Abbreviations

#### Conventions

Numbered lists indicate procedures.

Bullet lists indicate other information and descriptions of illustrations.

Italicised text indicates:

- Cross-reference.
- Link.
- Parameter name.
- Footnote.
- Parameter group.
- Parameter option.
- Alarms/warnings.

## 2

## 2 Safety

### 2.1 Safety Symbols

The following symbols are used in this manual:



Indicates a potentially hazardous situation that could result in death or serious injury.



Indicates a potentially hazardous situation that could result in minor or moderate injury. It can also be used to alert against unsafe practices.



Indicates important information, including situations that can result in damage to equipment or property.

### 2.2 Qualified Personnel

Correct and reliable transport, storage, installation, operation, and maintenance are required for the trouble-free and safe operation of the frequency converter. Only qualified personnel are allowed to install and operate this equipment.

Qualified personnel are defined as trained staff, who are authorised to install, commission, and maintain equipment, systems, and circuits in accordance with pertinent laws and regulations. Additionally, the qualified personnel must be familiar with the instructions and safety measures described in these operating instructions.

### 2.3 Safety Precautions



#### HIGH VOLTAGE

Frequency converters contain high voltage when connected to AC mains input, DC supply, or load sharing. Failure to perform installation, start-up, and maintenance by qualified personnel can result in death or serious injury.

- Only qualified personnel must perform installation, start-up, and maintenance.



#### UNINTENDED START

When the frequency converter is connected to AC mains, DC supply, or load sharing, the motor may start at any time. Unintended start during programming, service, or repair work can result in death, serious injury, or property damage. The motor can start with an external switch, a fieldbus command, an input reference signal from the LCP or LOP, via remote operation using MCT 10 Set-up Software, or after a cleared fault condition.

To prevent unintended motor start:

- Disconnect the frequency converter from the mains.
- Press [Off/Reset] on the LCP before programming parameters.
- Completely wire and assemble the frequency converter, motor, and any driven equipment before connecting the frequency converter to AC mains, DC supply, or load sharing.



#### DISCHARGE TIME

The frequency converter contains DC-link capacitors that can remain charged even when the frequency converter is not powered. Failure to wait the specified time after power has been removed before performing service or repair work, can result in death or serious injury.

- Stop the motor.
- Disconnect the AC mains and remote DC-link supplies, including battery back-ups, UPS, and DC-link connections to other frequency converters.
- Disconnect or lock the PM motor.
- Wait for the capacitors to discharge fully before performing any service or repair work. The duration of waiting time is specified in the relevant frequency converter operating instructions, *Chapter 2 Safety*.



#### LEAKAGE CURRENT HAZARD

Leakage currents exceed 3.5 mA. Failure to ground the frequency converter properly can result in death or serious injury.

- Ensure the correct grounding of the equipment by a certified electrical installer.

**⚠ WARNING****EQUIPMENT HAZARD**

Contact with rotating shafts and electrical equipment can result in death or serious injury.

- Ensure that only trained and qualified personnel perform installation, start-up, and maintenance.
- Ensure that electrical work conforms to national and local electrical codes.
- Follow the procedures in this manual.

**⚠ CAUTION****INTERNAL FAILURE HAZARD**

An internal failure in the frequency converter can result in serious injury, when the frequency converter is not properly closed.

- Ensure that all safety covers are in place and securely fastened before applying power.

### 3 Installation

3

#### 3.1 Safety Instructions

See *chapter 2 Safety* for general safety instructions.

#### 3.2 EMC-compliant Installation

To obtain an EMC-compliant installation, follow the instructions provided in the relevant frequency converter *operating instructions* and *design guide*. Refer to the fieldbus master manual from the PLC supplier for further installation guidelines.

#### 3.3 Grounding

- Ensure that all stations connected to the fieldbus network are connected to the same ground potential. When there are long distances between the stations in a fieldbus network, connect the individual station to the same ground potential. Install equalising cables between the system components.
- Establish a grounding connection with low HF impedance, for example by mounting the frequency converter on a conductive back plate.
- Keep the ground wire connections as short as possible.
- Establish electrical contact between the cable screen and the frequency converter enclosure by using metal cable glands or by using the clamps provided on the equipment.
- Use high-strand wire to reduce electrical interference.

#### 3.4 Cable Routing

**NOTICE**

**EMC INTERFERENCE**

Use screened cables for motor and control wiring, and separate cables for fieldbus communication, motor wiring, and brake resistor. Failure to isolate fieldbus communication from motor and brake resistor cables can result in unintended behaviour or reduced performance. Minimum 200 mm (7.9 in) clearance between power, motor, and control cables is required. For power sizes above 315 kW, it is recommended to increase the minimum distance to 500 mm (20 in).

**NOTICE**

When the fieldbus cable crosses a motor cable or a brake resistor cable, ensure that the cables cross at an angle of 90°.

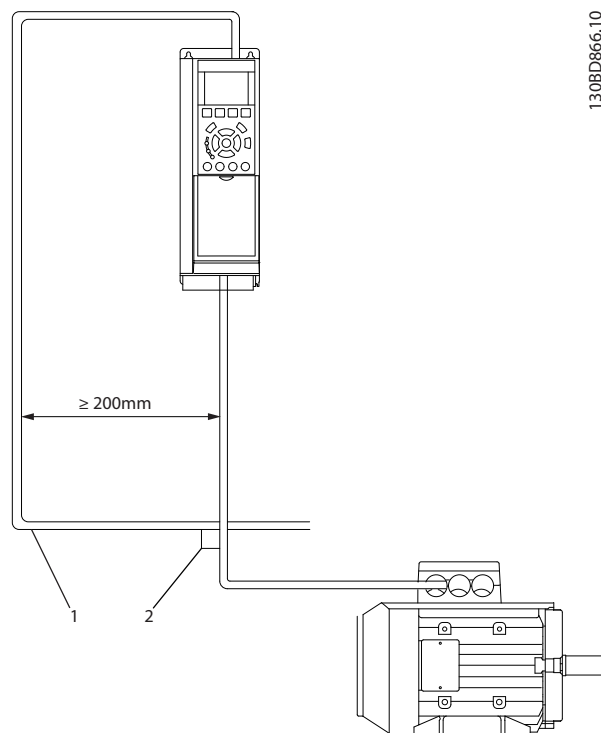

1	Fieldbus cable
2	90° crossing

Illustration 3.1 Cable Routing



### 3.5 Mounting

1. Check whether the fieldbus option is already mounted in the frequency converter. If already mounted, go to step 6. If not mounted, go to step 2.
2. Remove the LCP or blind cover from the frequency converter.
3. Use a screwdriver to remove the front cover and the LCP cradle.
4. Mount the fieldbus option. Mount the option with the connector facing up for top cable entry (see *Illustration 3.3*), or with the connector facing down for bottom cable entry (see *Illustration 3.4*). If an MCB option is installed, only top cable entry is possible.
5. Remove the knock-out plate from the new LCP cradle.
6. Mount the new LCP cradle.

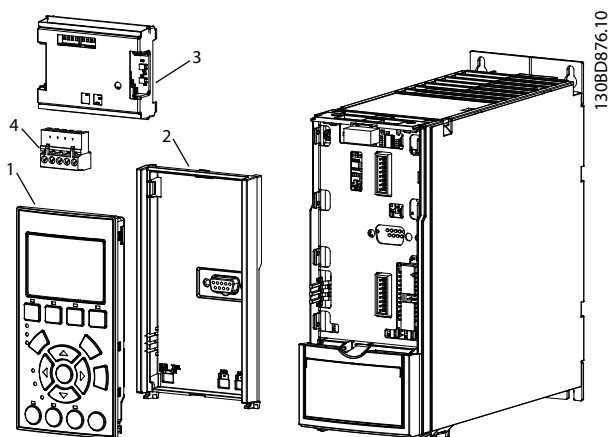

1	LCP
2	LCP cradle
3	Fieldbus option
4	Connector

Illustration 3.2 Exploded View

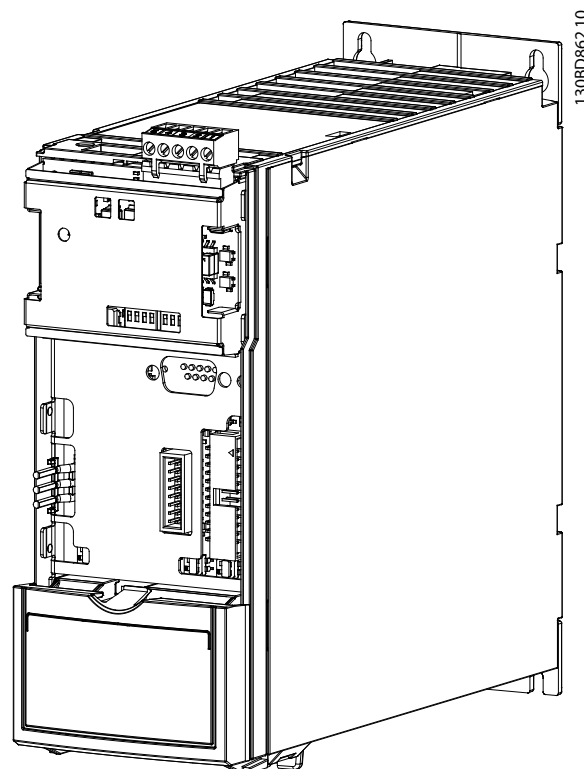

Illustration 3.3 Top Cable Entry: Option Mounted with Connector Facing Up

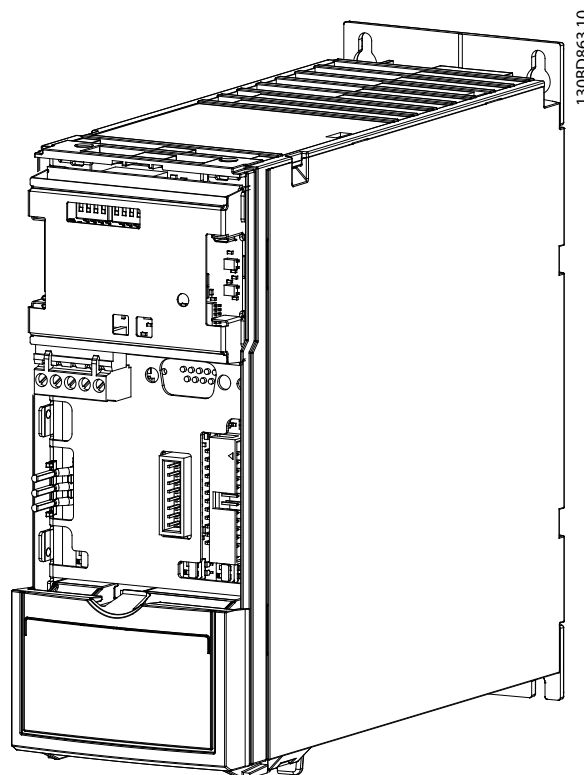

Illustration 3.4 Bottom Cable Entry: Option Mounted with Connector Facing Down

### 3.6 Setting Address Switches

**NOTICE**

Switch off the power supply before changing the address switches. The address change comes into effect at the next power-up.

The address switches enable setting of baudrate and node ID:

- Switches 8 and 7 are for setting the baudrate for either: 125, 250, or 500 Kbps.
- Switches 6–1 are for setting the node address in the range 1–62.

Switch		Baudrate
8	7	
On	On	Parameter 10-01 Baud Rate Select
On	Off	500 kbps
On	On	250 kbps
On	Off	125 kbps

Table 3.1 Switches 8 and 7

Switch						Node ID
6	5	4	3	2	1	
On	On	On	On	On	On	Parameter 10-02 MAC ID
On	On	On	On	On	Off	62
Off	Off	Off	Off	Off	On	1

Table 3.2 Switches 6–1

When both switch 8 and 7 are set to ON, select baudrates via parameter 10-01 Baud Rate Select: 10, 20, 50, 100, 125, 250, or 500 kbps.

When switches 6–1 are set to ON, select node ID via parameter 10-02 MAC ID in the range: 1–127

### 3.7 Electrical Installation

#### 3.7.1 Cable Specifications

Baudrate [kbps]	Maximum cable length [m]	Resistance [mΩ/m]	Cable cross-section [mm <sup>2</sup> ]	Termination resistor [Ω]
500	100	<60	0.34–0.6	120
250	250	<40	0.5–0.6	
125	500			
50	1000	<26	0.75–0.8	
20	2500			
10	5000			

Table 3.3 Cable Specifications

#### 3.7.2 Wiring Procedures

##### Wiring procedure for enclosure sizes A1–A3

1. Mount the fieldbus connector on the fieldbus option (CAN\_L, Drain, CAN\_H). For top cable entry, mount the supplied EMC bracket on top of the frequency converter with 2 screws.
2. Prepare the fieldbus cable by stripping a section of the cable insulation, so that the cable screen contacts the EMC bracket. Keep the unshielded wire as short as possible. For cable specifications, refer to chapter 3.7.1 Cable Specifications.
3. Connect the fieldbus cable wires to the terminals according to the colour code of the wires, see Illustration 3.6.
4. To establish mechanical fixation and electrical contact between cable screen and ground, position the stripped cable between the spring loaded metal clamps.

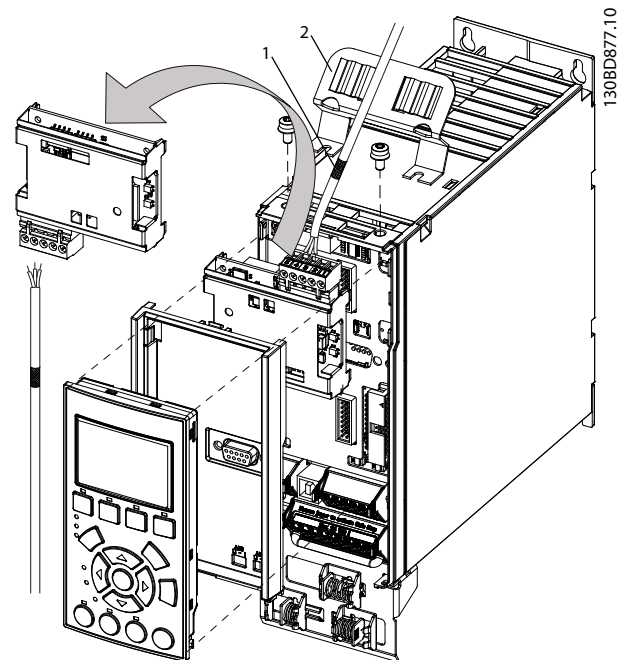

1	Cable screen
2	EMC bracket (used for top cable entry only)

Illustration 3.5 Wiring for Enclosure Sizes A1–A3

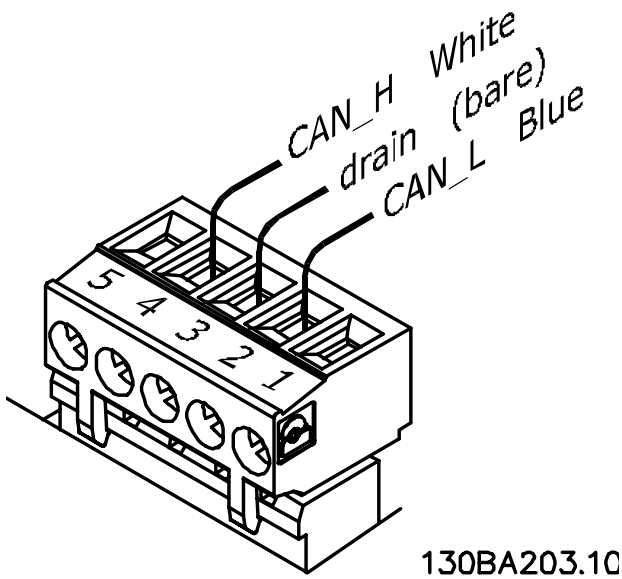

Pin no.	Terminal	Colour	Name
1	-	-	Not used
2	CAN_L	Blue	CAN LOW
3	Drain	(bare)	Screen
4	CAN_H	White	CAN HIGH
5	-	-	Not used

Illustration 3.6 Fieldbus Cable Terminal Connections

**CANopen termination**

Install the termination resistors at each end of the bus line. Mount the resistor between terminal 2 (CAN\_L) and terminal 4 (CAN\_H).

The resistors have the following specification:

- 121 Ω
- 1% Metal film
- 1/4 W

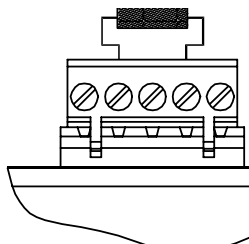

Illustration 3.7 Termination Resistor Mounted

**Wiring procedure for enclosure sizes A4–A5, B1–B4, and C1–C4**

1. Push the cable through cable glands.
2. Mount the fieldbus connector on the fieldbus option (CAN\_L, Drain, CAN\_H).
3. Prepare the fieldbus cable by stripping a section of the cable insulation. Keep the unshielded wire as short as possible. For cable specifications, refer to *chapter 3.7.1 Cable Specifications*.
4. Connect the fieldbus cable wires to the terminals according to the colour code of the wires, see *Illustration 3.6*.
5. Fix the cable screen to the metal base plate using cable clamp or cable tie, see *Illustration 3.8*.
6. Tighten cable glands securely.

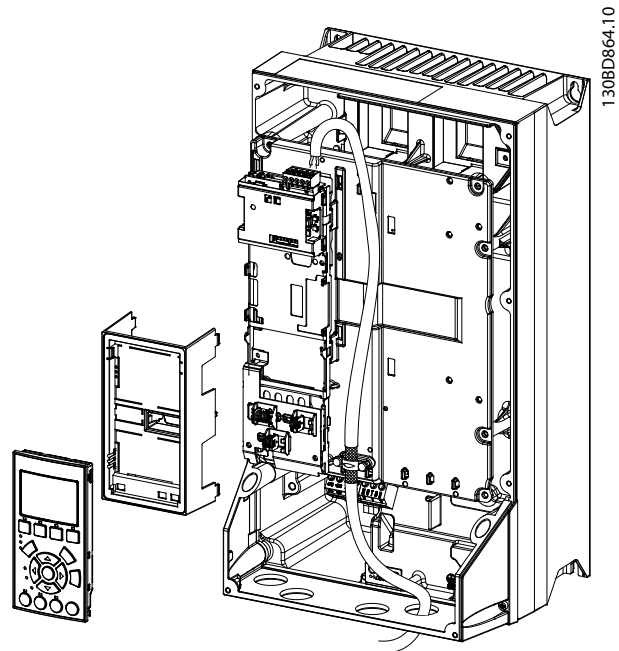

Illustration 3.8 Wiring for Enclosure Sizes A4–A5, B1–B4, and C1–C4

### Wiring procedure for enclosure sizes D, E, and F

1. Mount the fieldbus connector on the fieldbus option (CAN\_L, Drain, CAN\_H).
2. Prepare the fieldbus cable by stripping a section of the cable insulation. Keep unshielded wire as short as possible. For cable specifications, refer to *chapter 3.7.1 Cable Specifications*.
3. Connect the fieldbus cable wires to the terminals according to the colour code of the wires, see *Illustration 3.6*.
4. Fix the cable screen to the metal base plate using cable clamp or cable tie, see *Illustration 3.9*.
5. Tie down the cable and route it with other control wires inside the unit, see *Illustration 3.9*.

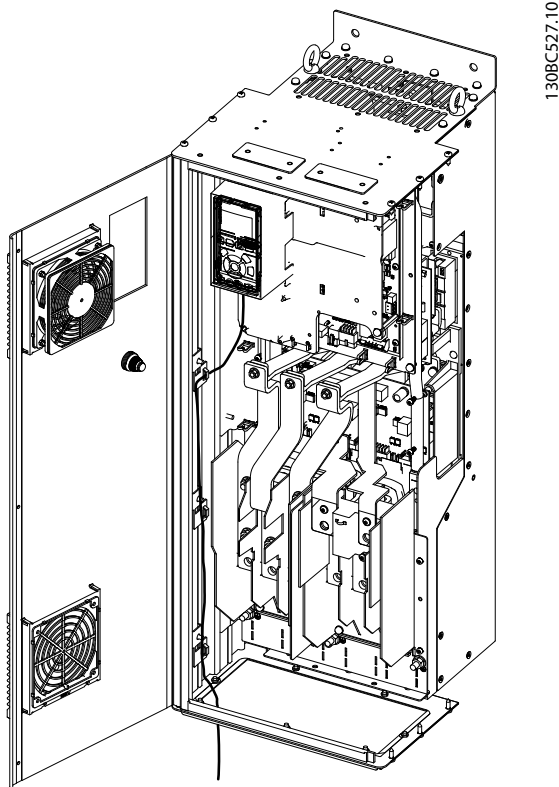

Illustration 3.9 Wiring for Enclosure Sizes D, E, and F

### 3.8 Reassembling Cover

1. Mount the new front cover and the LCP.
2. Attach the sticker with the correct product name to the front cover.

### 3.9 Applying Power

Follow the instructions in the frequency converter *operating instructions* to commission the frequency converter. The frequency converter automatically detects the CANopen interface. A new parameter group (Group 10) appears.

### 3.10 Checking Network Cabling

1. If the address has not been set via the address switches, go to *parameter 10-02 MAC ID* to set the address.
2. Connect to a running CANopen master.
3. Check that network cabling is correct or not.

## 4 Troubleshooting

### 4.1 Warnings and Alarms

#### NOTICE

Refer to the relevant *operating instructions* for an overview of warning and alarm types and for the full list of warnings and alarms.

Alarm word, warning word, and CANopen warning word are shown on the frequency converter display in hex format. When there is more than 1 warning or alarm, the sum of all warnings or alarms is shown. Alarm word, warning word, and CANopen warning word can also be displayed using the serial bus in:

- Parameter 16-90 Alarm Word.
- Parameter 16-91 Alarm Word 2.
- Parameter 16-92 Warning Word.
- Parameter 16-93 Warning Word 2.

### 4.2 Troubleshooting

#### 4.2.1 LED Status

The 2 bi-colour LEDs on the CANopen card indicate the status of CANopen communication:

- The lower LED (NS) indicates the net status.
- The upper LED (MS) indicates the module status.

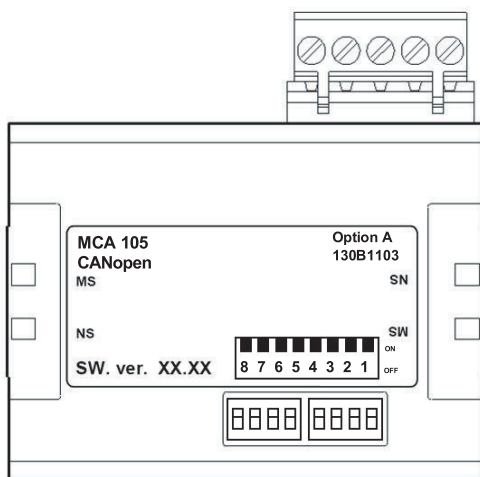

130BA896.10

Illustration 4.1 LED Panel VLT® CANopen MCA 105

State	Red LED	Description
No error	Off	No error.
Warning limit reached	Single flash	CAN error counter has reached/exceeded warning level.
Error control event	Double flash	Node guard event has occurred.
Sync error	Triple flash	Sync message has not been received within the configured timeout (object 0x1006).
Bus off	On	Device in bus off-state.

Table 4.1 LED: Module Status (MS)

State	Red LED	Description
Stopped	Single flash	Device in stopped state.
Pre-operational	Triple flash	Device in pre-operational state.
Operational	On	Device in operational state.

Table 4.2 LED: Network Status (NS)

#### 4.2.2 No Communication with the Frequency Converter

When there is no communication with the frequency converter, proceed with the following checks:

1. Check that cabling is correct. Check that the cables are connected to the correct terminals as shown in *Illustration 3.6*.
2. Check that the bus connection is terminated at both ends. If not, terminate the bus connection with termination resistors at the initial and final nodes.
3. Check that each node connected to the CANopen network has a unique node ID (address). If 2 devices have the same node ID, it leads to malfunction in the network.
4. Communication drops out after some time. Check the installation for correct routing of the CANopen cables. Check if the screen of the motor cable is mounted correctly.
5. Communication is unstable. Check *parameter 10-05 Readout Transmit Error Counter* and *parameter 10-06 Readout Receive Error Counter*. These 2 parameters have to be close to 0 most of the time. If they show higher values, check the CANopen cable for interference, wrong termination, and so on.

**Index**

**A**

Abbreviations..... 3  
 Additional resources..... 2  
 Address switch..... 8, 10  
 Alarm..... 11  
 Alarm word..... 11  
 Applying power..... 10  
 Approvals..... 2

**C**

Cable specifications..... 8  
 Cable terminal connections..... 9  
 CANopen termination..... 9  
 Certifications..... 2  
 Conventions..... 3

**D**

Discharge time..... 4

**E**

Electrical interference..... 6  
 EMC interference..... 6  
 EMC-compliant installation..... 6  
 Exploded view..... 7

**G**

Grounding..... 6

**H**

High voltage..... 4

**I**

Intended use..... 2  
 Items supplied..... 2

**L**

Leakage current..... 4  
 LED panel..... 11  
 LED status..... 11  
 Load sharing..... 4

**M**

Motor wiring..... 6  
 Mounting..... 7

**N**

Network cabling..... 10

**P**

Power, applying..... 10

**Q**

Qualified personnel..... 4

**S**

Safety..... 5  
 Screened cable..... 6  
 Symbols..... 3

**U**

Unintended start..... 4

**W**

Warning..... 11  
 Warning word..... 11  
 Wiring procedure..... 8





.....  
Danfoss can accept no responsibility for possible errors in catalogues, brochures and other printed material. Danfoss reserves the right to alter its products without notice. This also applies to products already on order provided that such alterations can be made without subsequential changes being necessary in specifications already agreed. All trademarks in this material are property of the respective companies. Danfoss and the Danfoss logotype are trademarks of Danfoss A/S. All rights reserved.  
.....

Danfoss A/S  
Ulsnaes 1  
DK-6300 Graasten  
vlt-drives.danfoss.com

