



# Operating Instructions

## VLT<sup>®</sup> PROFIBUS Converter MCA 114

VLT<sup>®</sup> AutomationDrive FC 302 • VLT<sup>®</sup> 5000





## Contents

<b>1 Introduction</b>	<b>3</b>
1.1 About this Manual	3
1.2 Technical Overview	3
1.3 Constraints	3
1.3.1 Software Versions	3
1.3.2 Relations	4
1.3.3 Hardware	4
1.3.4 Performance	5
1.4 Abbreviations	5
<b>2 Safety</b>	<b>6</b>
<b>3 How to Install</b>	<b>7</b>
3.1 Connecting the Bus Line	7
3.2 How to Install Option in Frequency Converter	7
3.2.1 Mechanical Installation	8
3.3 EMC Precautions	8
<b>4 How to Configure the System</b>	<b>9</b>
4.1 Configure the PROFIBUS Network	9
4.1.1 Setting the PROFIBUS Address using the Hardware Switches	9
4.1.2 Setting the PROFIBUS Address via 9-18 Node Address	9
4.1.3 Commissioning	10
4.2 LED Behaviour	10
4.3 Initialisation	11
<b>5 Parameter Mapping Lists</b>	<b>12</b>
5.1 VLT® 5000 Parameter Group 0	12
5.2 VLT® 5000 Parameter Group 1	14
5.3 VLT® 5000 Parameter Group 2	18
5.4 VLT® 5000 Parameter Group 3	21
5.5 VLT® 5000 Parameter Group 4	29
5.6 VLT® 5000 Parameter Group 5	34
5.7 VLT® 5000 Parameter Group 6	36
5.8 VLT® 5000 Parameter Group 7	38
5.9 VLT® 5000 Parameter Group 8	39
5.10 VLT® 5000 Parameter Group 9	40
<b>6 Troubleshooting</b>	<b>43</b>
6.1 Step-by-step Troubleshooting	43

<b>Index</b>	44
--------------	----

# 1 Introduction

## 1.1 About this Manual

First-time users can find the most essential information for quick installation and set-up in these chapters:

*1.2.1 Technical Overview*

*1.3 Constraints*

*3 How to Install*

For more detailed information including the full range of set-up options and diagnosis tools, refer to:

*4 How to Configure the System*

*5 Parameter Mapping Lists*

### 1.1.1 FC 300-related Literature

The following literature is available for the FC 300 series:

- VLT® AutomationDrive FC 302 Operating Instructions
- VLT® AutomationDrive FC 302 Design Guide
- VLT® AutomationDrive FC 302 Programming Guide

[www.danfoss.com/BusinessAreas/DrivesSolutions/Documentations/VLT+Technical+Documentation.htm](http://www.danfoss.com/BusinessAreas/DrivesSolutions/Documentations/VLT+Technical+Documentation.htm)

## 1.2 Technical Overview

The MCA 114 Profibus Converter is an option replacing a VLT® 5000 with a VLT® AutomationDrive FC 302 in a PROFIBUS network.

With this PROFIBUS converter option the FC 302 reacts as a VLT® 5000 on the PROFIBUS network. Changes to PLC programming or configuration are normally not necessary.

The FC 302 identifies itself as a VLT® 5000 on the PROFIBUS network, and a write command to e.g. Ramp Up Time in VLT® 5000 is automatically linked to the corresponding ramp up time parameter in VLT® AutomationDrive FC 302.

### **NOTICE**

Some parameters in the VLT® 5000 are not supported in the FC 302 and some FC 302 parameters cannot be accessed via the PROFIBUS converter option MCA 114. Refer to *5 Parameter Mapping Lists* for more information. If a write request is attempted to a parameter selection not supported, the frequency converter discards the value and issues a positive reply. Only parameters and functions described in this manual are supported.

### **NOTICE**

The replacement frequency converter must match the power size, or be bigger than the replaced VLT® 5000. Make sure that the brake chopper matches the new frequency converter. Make sure that the new frequency converter meets the local regulations concerning the machinery directive, prefuses, and other appropriate regulations.

### **NOTICE**

Observe local rules and regulations when replacing frequency converter in existing installations.

## 1.3 Constraints

### 1.3.1 Software Versions

- VLT® AutomationDrive FC 302 with firmware version 5.5X or higher.
- The MCA 114 Profibus Converter firmware is based on a VLT® 5000 software version 3.9x and PROFIBUS software version 4.5x.

### 1.3.2 Relations

This manual relates to the following hardware:

- VLT® PROFIBUS Converter option, type no. 130B1246
- MCB 101 General I/O option, type no. 130B1125 (uncoated), 130B1212 (coated)
- MCB 107 External 24 Volt DC Supply, type no. 130B1108 (uncoated), 130B1208 (coated)
- PROFIBUS adaptor Sub-D9 connector, type no. 130B1112. for enclosure types A1, A2 & A3
- PROFIBUS adaptor Sub-D9 connector, type no. 176F1742 for enclosure types D & E

### 1.3.3 Hardware

- The VLT® PROFIBUS Converter MCA 114 supports VLT® AutomationDrive FC 302 only.
- There is no support for PROFIBUS FMS networks.
- The FC 302 has fewer digital I/Os and analog output signals than VLT® 5000. The General I/O Option MCB 101 must be mounted in FC 302 to map these signals and utilise all I/Os.

VLT® 5000		FC 302	
Terminal	Function	Terminal	Function
01-03	Relay	01-03	Relay
68	RS-485-P	68	RS-485-P
69	RS-485-N	69	RS-485-N
61	GND RS-485	61	GND RS-485
12	24 V out	12	24 V out
13	24 V out	13	24 V out
50	10 V out	50	10 V out

Table 1.1 Terminal Mapping

\* = General I/O option MCB 101

\*\* = Switch "S201" must be OFF

\*\*\* = Switch "S202" must be ON

VLT® 5000		FC 302	
Terminal	Function	Terminal	Function
16	Digital input	X30/2*	Digital input
17	Digital input	X3/3*	Digital input
18	Digital input	18	Digital input
19	Digital input	19	Digital input
27	Digital input	27	Digital input
29	Digital input	29	Digital input
32	Digital input	32	Digital input
33	Digital input	33	Digital input
20	GND Digital input	20	GND Digital input
53	Analog input voltage	53	Analog input voltage**
54	Analog input voltage	X30/11***	Analog input voltage
60	Analog input current	54	Analog input current***
55	GND analog/digital input voltage	55	GND analog/digital input voltage
42	Analog/digital output	42	Analog output 0/4-20 mA
		X30/6*	Digital output
		X30/7*	Pulse output
39	GND analog/digital output	39	GND analog /digital output
04-05	Relay	04-06	Relay

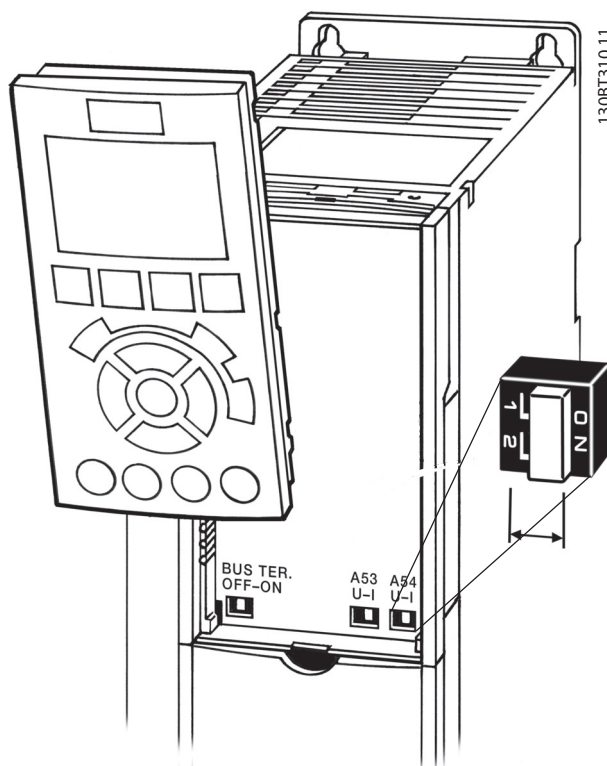

Illustration 1.1 Location of Switches S801, S201, and S202 (Left to Right)

### 1.3.4 Performance

- The dynamic performance on the motor shaft in the closed loop operation compared with VLT® 5000 can be different in certain applications. If necessary, adjust the PID controller manually.
- The motor control algorithm of the VLT® AutomationDrive FC 302 results in a better motor performance compared to VLT® 5000.

#### **NOTICE**

##### Factory values:

After initialisation most parameters are set to match the factory settings of the VLT® 5000 parameters. For more information about the initialisation, see the *VLT AutomationDrive FC 301/302 Programming Guide*.

#### **NOTICE**

##### Linked Set-ups:

To synchronise set-up changes made with running motor, ensure that FC 302 setups are linked. This is done in *0-12 This Set-up Linked to*.

### 1.4 Abbreviations

AOC	Application oriented control
CTW	Control word
EMC	Electromagnetic Compatibility
I/O	Input/Output
LED	Light Emitting Diode
LSB	Least Significant Bit
MAV	Main Actual Value (actual output)
MOC	Motor oriented control
MSB	Most Significant Bit
MRV	Main Reference Value (Setpoint)
N/A	Not applicable
PCD	Peripherals Communication Data (process data)
PCV	Parameter Characteristics Value (Parameter channel)
PLC	Programmable Logic Controller
PNU	Parameter Number
PPO	Parameter Process Data Object
PU	Power Unit
REF	Reference (= MRV)
STW	Status Word

Table 1.2 Abbreviations

## 2 Safety

### **⚠ WARNING**

#### HIGH VOLTAGE

Frequency converters contain high voltage when connected to AC mains input power. Failure to perform installation, start-up, and maintenance by qualified personnel could result in death or serious injury.

- **Installation, start-up, and maintenance must be performed by qualified personnel only.**

#### Safety regulations

1. The frequency converter must be disconnected from mains, if repair work is to be carried out. Check that the mains supply has been disconnected and that the necessary time has passed before removing motor and mains plugs, see *Discharge Time Table*.
2. The [Off] key does not disconnect the equipment from mains and is thus not to be used as a safety switch.
3. Correct protective earthing of the equipment must be established, the user must be protected against supply voltage, and the motor must be protected against overload in accordance with applicable national and local regulations.
4. The earth leakage currents are higher than 3.5 mA.
5. Protection against motor overload is not included in the factory setting. If this function is desired, set *1-90 Motor Thermal Protection [4] ETR trip* or *[3] ETR warning*.

The function is initialised at 1.16 x rated motor current and rated motor frequency. For the North American market; the ETR functions provide class 20 motor overload protection in accordance with NEC.

6. Do not remove the plugs for the motor and mains supply while the frequency converter is connected to mains. Check that the mains supply has been disconnected and that the necessary time has passed before removing motor and mains plugs, see *Discharge Time Table*.
7. The frequency converter has more voltage inputs than L1, L2 and L3, when load sharing (linking of DC intermediate circuit) and external 24 V DC have been installed. Check that all voltage inputs have been disconnected and that the necessary time has passed before commencing repair work, see *Discharge Time Table*.

#### Warning against unintended start

1. The motor can be brought to a stop with digital commands, bus commands, references or a local stop, while the frequency converter is connected to mains. These stop functions are not sufficient to prevent unintended starts.
2. While parameters are being changed, the motor may start. Consequently, [Off] must always be activated.
3. A motor that has been stopped may start if faults occur in the electronics of the frequency converter, or if a temporary overload or a fault in the supply mains or the motor connection ceases.

### **⚠ WARNING**

**Touching the electrical parts may be fatal - even after the equipment has been disconnected from mains.**

Voltage [V]	Minimum waiting time (minutes)	
	4	15
200-240	0.25-3.7 kW	5.5-37 kW
380-480	0.25-7.5 kW	11-75 kW
525-600	0.75-7.5 kW	11-75 kW
525-690		11-75 kW
High voltage may be present even when the warning LED indicator lights are off.		

**Table 2.1 Discharge Time**

Also make sure that other voltage inputs have been disconnected, such as external 24 V DC, load sharing (linkage of DC intermediate circuit), as well as the motor connection for kinetic back up.



### 3 How to Install

#### 3.1 Connecting the Bus Line

Terminate the bus line at both ends of each segment. A mismatch of impedance may result in reflections on the line resulting in corrupt data transmission.

The Profibus Option Card contains a suitable termination. To activate the termination, turn on *Switch 1* on the Profibus converter option. By default, the switch is turned off.

**NOTICE**

Notice that pin numbers are colour coded on the Profibus connector.

Unlike the VLT® 5000, the FC 302 Profibus connectors are colour-coded to avoid swapping the bus wires.

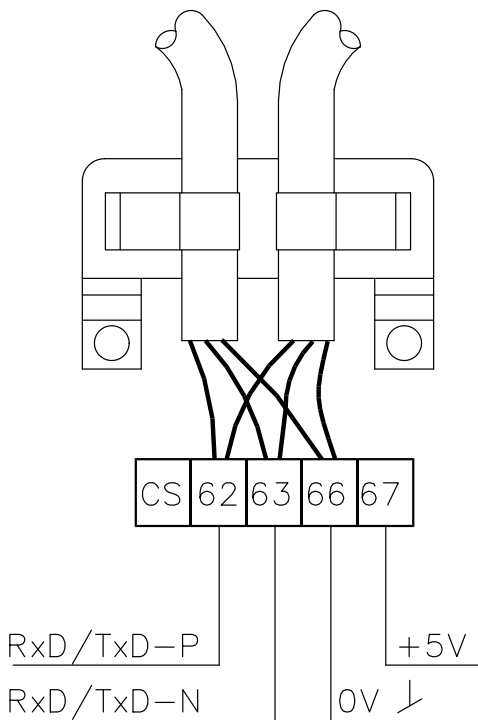

Illustration 3.1 Connecting Bus Wires to VLT PROFIBUS Converter MCA 114

Profibus B	62 = RxD/TxD	Positive, red cable
Profibus A	63 = RxD/TxD	Negative, green cable

Table 3.1 Correct Colour-Coding

#### 3.2 How to Install Option in Frequency Converter

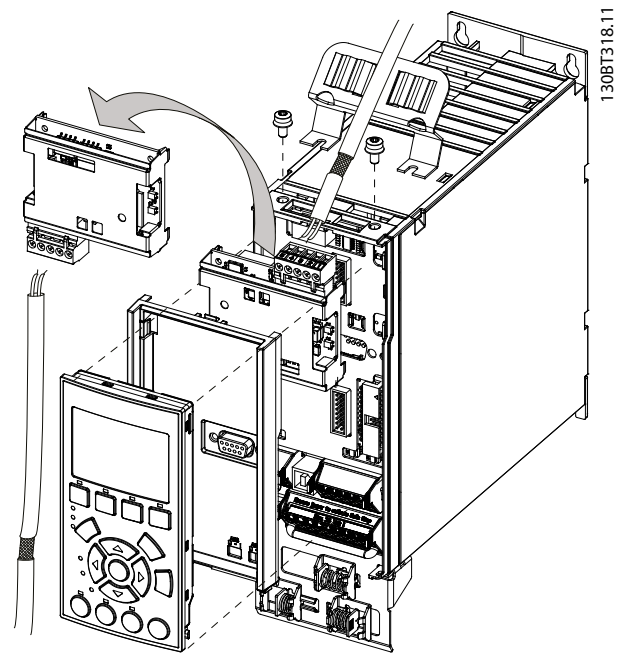

Illustration 3.2 Installing Fieldbus Option

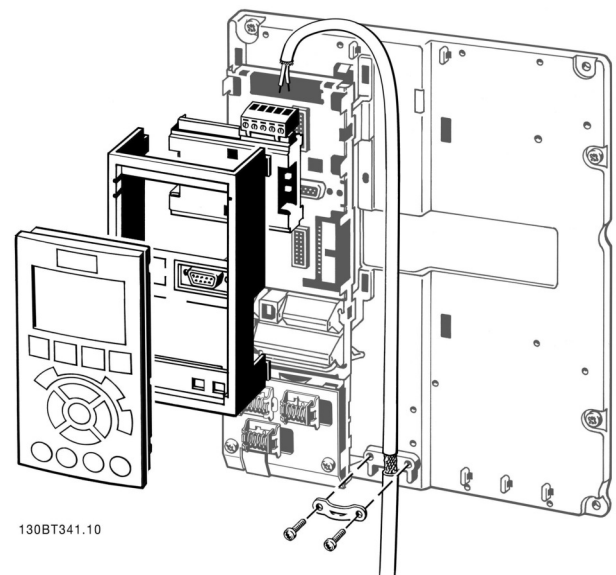

Illustration 3.3 Cable Holders

1. Remove the LCP from the FC 302.
2. Remove the frame below the local control panel.

3. Push the option into place. Two positions are possible, with cable terminal facing either up or down. The cable up position is often most suitable when several frequency converters are installed side by side in a rack, as this position permits shorter cable lengths.
4. Push the fieldbus option adaptor frame for the FC 302 into place.
5. Remount the LCP.
6. Attach the cable.
7. Fasten the cable using cable holders.

### 3.2.1 Mechanical Installation

To ease the replacement of VLT 5000 with VLT® AutomationDrive FC 302, there is a number of adapter plates available. The adapter plates have the same footprints as VLT 5000 and have threaded holes for VLT® AutomationDrive FC 302. The adapter plate prevents damage that can occur from drilling new threaded holes in the backboard of the enclosure. The adapter plate also decreases the time required to exchange a broken frequency converter.

The following mechanical adapter plates are available:

Ordering number	Style	Height [mm]	Width [mm]	Type
130B0183	Bookstyle, IP20	395	90	5001-5003 200-240 V 5001-5005 380-500 V
130B0184	Bookstyle, IP20	395	130	5004-5006 200-240 V 5006-5011 380-500 V
130B0185	Compact, IP20	395	220	5001-5003 200-240 V 5001-5005 380-500 V 5004-5006 200-240 V 5006-5011 380-500 V 5001-5011 550-600 V

Table 3.2 Mechanical Installation for VLT® 5000

### 3.3 EMC Precautions

To achieve interference-free operation of the PROFIBUS:

- Maintain high distance (min. 200 mm [8"]) between the PROFIBUS communication cable and the motor and brake resistor cables to avoid coupling of high frequency noise from one cable to the other.
- When crossing is unavoidable, ensure that the PROFIBUS cable crosses motor and brake resistor cables at an angle of 90 degrees.

**NOTICE**

Observe relevant national and local regulations, for example regarding protective earth connection.

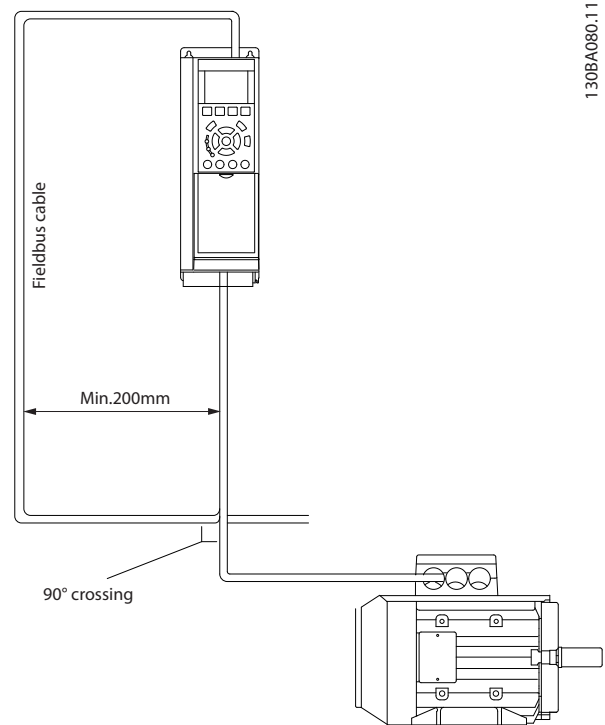

Illustration 3.4 Correct EMC Installation

## 4 How to Configure the System

### 4.1 Configure the PROFIBUS Network

All PROFIBUS stations connected to the same bus network must have a unique station address. Before a VLT® 5000 can be replaced with an FC 302 with MCA 114, only the station address needs to be configured in the FC 302.

The PROFIBUS address of the FC 302 can be selected via:

- Hardware switches
- 9-18 Node Address

**NOTICE**

After installing PROFIBUS Converter MCA 114, check that 8-02 Control Word Source is set to [3] Option A.

#### 4.1.1 Setting the PROFIBUS Address using the Hardware Switches

Using the hardware switches, select an address range from 0 to 125 (factory setting 127) according to *Illustration 4.1*: ON = 1, OFF = 0

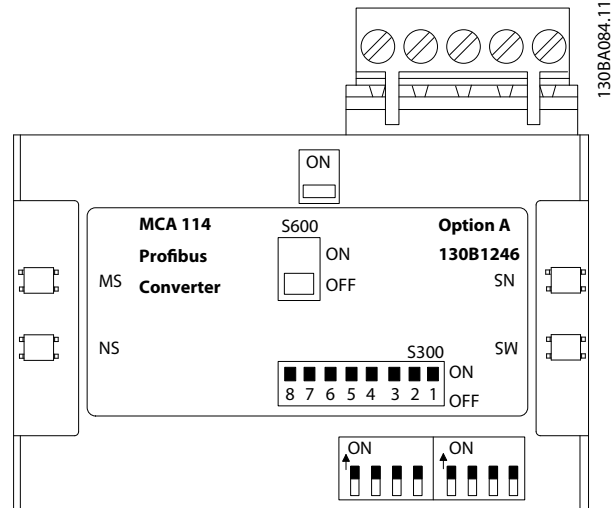

Illustration 4.1 PROFIBUS Option A

**CAUTION**

Switch off the power supply before changing the hardware switches.

**CAUTION**

The address change comes into effect at the next power-up, and can be read in 9-18 Node Address

	VLT® 5000								FC 302							
Switch	1	2	3	4	5	6	7	8	8	7	6	5	4	3	2	1
Address	+1	+2	+4	+8	+16	+32	+64	-	-	+64	+32	+16	+8	+4	+2	+1
Example:																
1	1	0	0	0	0	0	0	-	-	0	0	0	0	0	0	1
35	1	1	0	0	0	1	0	-	-	0	1	0	0	0	1	1
82	0	1	0	0	1	0	1	-	-	1	0	1	0	0	1	0

Table 4.1 Hardware Switches

#### 4.1.2 Setting the PROFIBUS Address via 9-18 Node Address

Setting the address via 9-18 Node Address or the PROFIBUS SSA-command is possible, if the hardware switches are set to 126 or 127 (factory switch setting). The new address becomes active at the next power-up.

### 4.1.3 Commissioning

After setting the station address from VLT® 5000 to VLT® AutomationDrive FC 302, cycle power on the frequency converter to activate the new address. The master/PLC now recognizes the frequency converter as VLT® 5000. A solid green NS LED on the MCA 114 option indicates that communication between the master and the frequency converter is established. If the NS LED flashes, the master/PLC has not recognised the frequency converter.

For more information, refer to 6.1 Step-by-step Troubleshooting

### 4.2 LED Behaviour

The option has 2 bi-coloured LEDs:

LED label	Description
NS	Network Status
MS	Modul Status ( DP-V1 communication)

Table 4.2 Bi Coloured LEDs

State	LED	Description
Power On	Red:	Solid red The option is defect. Contact Danfoss
	Green:	Flashing green The option is OK.
Baud rate search	Green:	Flashing green Searching for the baud rate. Check the connection to the master if the option stays in this state.
Wait Parameterising	Green:	Long green flash Baud rate found - waiting for parameters from the master.
	Red:	Long red flash Wrong parameters from the master.
Wait Configuration	Green:	Short green flash Parameters from master OK – waiting for configuration data.
	Red:	Short red flash Wrong Configuration data from the master.
Data Exchange	Green:	Solid green Data Exchange between the master and the FC 300 is active.
	Red:	Flashing red Clear State. Warning 34 is active and a bus reaction in par. 8-04 is executed.

Table 4.3 Net Status

LED	Description
No light	Off No PROFIBUS DPV1 communication is active.
Green:	Short green flash DP V1 communication from a Master Class 1 (PLC) is active.
Green:	Long green flash DP V1 communication from a Master Class 2 (MCT 10, FDT) is active.
Green:	Solid green DP V1 communication from a Master Class 1 and 2 is active.
Red:	Flashing red Internal error.

Table 4.4 Module Status ( DP-V1 Communication)

### NOTICE

The LEDs flash patterns of the MCA114 are not compatible with the patterns of the VLT®5000 PROFIBUS LEDs.

### 4.3 Initialisation

To achieve the best performance, initialise the frequency converter after the option is mounted. If the frequency converter is delivered from factory with the option installed, skip this step. The initialisation is done via 14-22 *Operation Mode* or a 3 finger reset. The parameters of the FC 302 are set to factory values, and a number of FC 302 parameters are set to values that match the VLT® 5000 initial values.

Factory copy via VLT® 5000 parameter 006 is supported and initialises the FC 302 and also set it to the VLT® 5000 default settings.

The following parameters are set during the initialisation:

Parameter	Initialisation setting
0-02 Motor Speed Unit	[Hz]
1-52 Min Speed Normal Magnetising [Hz]	1.0 Hz
3-16 Reference Resource 2	[0] No function
4-12 Motor Speed Low Limit [Hz]	132.0 Hz
3-00 Reference Range	min – max
3-01 Reference/Feedback Unit	[1] %
3-11 Jog Speed [Hz]	10.0 Hz
4-30 Motor Feedback Loss Function	[0] Disabled
4-56 Warning Feedback Low	-4000000
4-57 Warning Feedback High	4000000
6-10 Terminal 53 Low Voltage	0.00 Volt
6-20 Terminal 54 Low Voltage	0.00 Volt
6-22 Terminal 54 Low Current	0.00 Volt
5-51 Term. 29 High Frequency	5000 Hz
5-56 Term. 33 High Frequency	25000 Hz
4-32 Motor Feedback Loss Timeout	1.00 s
14-21 Automatic Restart Time	5 s
14-03 Overmodulation	[0] Off
7-33 Process PID Proportional Gain	0.01
8-54 Reversing Select	[0] Digital input
8-90 Bus Jog 1 Speed	300 RPM
8-91 Bus Jog 2 Speed	300 RPM
7-04 Speed PID Differentiation Time	OFF
2-10 Brake Function	[0] Off
2-17 Over-voltage Control	[0] Off
5-40 Function Relay	[22] Ready, no thermal Warning
5-41 On Delay, Relay	[23] Remote, ready, no TW
7-09 Speed PID Error Correction w/ Ramp	100000 (max)
14-11 Mains Voltage at Mains Fault	calculated value: VLT5000 level = FC 302 level * 1,35 / sqrt(2)
<b>MCB 101 option specific parameters</b>	
5-16 Terminal X30/2 Digital Input	[1] Reset
5-17 Terminal X30/3 Digital Input	[19] Freeze reference
<b>PROFIBUS specific parameters</b>	
9-71 Profibus Save Data Values	[1] Store all setups

Table 4.5 Parameter Setup at Initialisation

## 5 Parameter Mapping Lists

### 5.1 VLT® 5000 Parameter Group 0

	VLT 5000 series	FC 302 series
Parameter	001 Language select	0-01 Language
Options	[0] English	[0] English
	[1] Deutsch	[1] Deutsch
	[2] French	[2] French
	[3] Dansk	[3] Dansk
	[4] Spanish	[4] Spanish
	[5] Italian	[5] Italian

Table 5.1 Conversion of Parameter 001

	VLT 5000 series	FC 302 series
Parameter	002 Local/remote control	Not converted
Options	[0] Remote	
	[1] Local with External Stop	
	[2] Local	

Table 5.2 Conversion of Parameter 002

	VLT 5000 series	FC 302 series
Parameter	003 Local reference	Not converted

Table 5.3 Conversion of Parameter 003

	VLT 5000 series	FC 302 series
Parameter	004 Active Set-up	0-10 Active Set-up
Options	[0] Factory Setup	[0] Factory Setup
	[1] Setup 1	[1] Setup 1
	[2] Setup 2	[2] Setup 2
	[3] Setup 3	[3] Setup 3
	[4] Setup 4	[4] Setup 4
	[5] Multi Setup	[9] Multi Setup

Table 5.4 Conversion of Parameter 004

	VLT 5000 series	FC 302 series
Parameter	005 Setup Copy	0-51 Set-up Copy
Options	[0] Factory Set-up	[0] Factory Set-up
	[1] Setup 1	[1] Setup 1
	[2] Setup 2	[2] Setup 2
	[3] Setup 3	[3] Setup 3
	[4] Setup 4	[4] Setup 4
	[5] Active Setup	[9] Active Setup

Table 5.5 Conversion of Parameter 005

	VLT 5000 series	FC 302 series
Parameter	006 Setup Copy	0-51 Set-up Copy
Options	[0] No Copy	[0] No Copy
	[1]	[1]
	[2]	[2]
	[3]	[3]
	[4]	[4]

Table 5.6 Conversion of Parameter 006

	VLT 5000 series	FC 302 series
Parameter	007 LCP Copy	Not converted

Table 5.7 Conversion of Parameter 007

	VLT 5000 series	FC 302 series
Parameter	008 Display scaling of motor frequency	Not converted

Table 5.8 Conversion of Parameter 008

	VLT 5000 series	FC 302 series
Parameter number	009 Display line	0-23
Parameter number	010 Display line	0-20
Parameter number	011 Display line	0-21
Parameter number	012 Display line	0-22
Options	[0] None	[0] None
	[1] Reference %	[1602] Reference %
	[2] Reference [Unit]	[1601] Reference [Unit]
	[3] Feedback [Unit]	[1652] Feedback [Unit]
	[4] Frequency [Hz]	[1613] Frequency [Hz]
	[5] Frequency x scale	[1609] Custom readout
	[6] Motor current [A]	[1614] Motor current [A]
	[7] Torque [%]	[1622] Torque [%]
	[8] Power [kW]	[1610] Power [kW]
	[9] Power [HP]	[1611] Power [HP]
	[10] Output energy [kWh]	[1502] kWh counter [kWh]
[11] Motor voltage [V]	[1612] Motor voltage [V]	

Table 5.9 Conversion of Parameters 009 to 012

	VLT 5000 series	FC 302 series
Parameter number	009	0-09 Performance Monitor
Parameter number	010	0-10 Active Set-up
Parameter number	011	0-11 Edit Set-up
Parameter number	012	0-12 This Set-up Linked to
Options	[12] DC link voltage [V]	[1630] DC link voltage [V]
	[13] Thermal load, motor [%]	[1618] Thermal load, motor [%]
	[14] Thermal load, VLT® [%]	[1635] Inverter thermal [%]
	[15] Running hours [hours]	[1501] Running hours [hours]
	[16] Digital input	[1660] Digital input
	[17] Analogue input 53 [V]	[1662] Analogue input 53 [V]
	[18] Analogue input 54 [V]	[1664] Analogue input 54 [V]
	[19] Analogue input 60 [mA]	[1662] Analogue input 53 [mA]
	[20] Pulse reference [Hz]	[1651] Pulse reference [Hz]
	[21] Ext. reference [%]	[1650] Ext. reference [%]
	[22] Status word [hex]	[1603] Status word [hex]
	[23] Brake effect/2 min [kW]	[1633] Brake effect/2 min [kW]
	[24] Brake effect/sec [kW]	[1632] Brake effect/sec [kW]
	[25] Heat sink temp.	[1634] Heat sink temp.
	[26] Alarm word [hex]	
	[27] Control word [hex]	[1600] Control word [hex]
	[28] Warning word 1 [hex]	
	[29] Warning word 2 [hex]	
	[30] Com. Option warning [hex]	[953] Com. Option warning [hex]
	[31] RPM [min]	[1617] Speed RPM [min]
	[32] RPM x scaling [min]	[1609] Custom readout
	[33] LCP display text	Not possible

Table 5.10 Conversion of Parameters 009 to 012

	VLT 5000 series	FC 302 series
Parameter	013 Local Ctrl./config	Not converted

Table 5.11 Conversion of Parameter 013

	VLT 5000 series	FC 302 series
Parameter	014 Local Stop key	0-41 [Off] Key on LCP
Options	[0] Disable	[0] Disable
	[1] Enable	[1] Enable
		[2] Password

Table 5.12 Conversion of Parameter 014

	VLT 5000 series	FC 302 series
Parameter	015 Local Jogging	Not converted
Options	[0] Disable	
	[1] Enable	

Table 5.13 Conversion of Parameter 015

	VLT 5000 series	FC 302 series
Parameter	016 Local Reversing	Not converted
Options	[0] Disable	
	[1] Enable	

Table 5.14 Conversion of Parameter 016

	VLT 5000 series	FC 302 series
Parameter	017 Local Stop key	0-43 [Reset] Key on LCP
Options	[0] Disable	[0] Disable
	[1] Enable	[1] Enable
		[2] Password

Table 5.15 Conversion of Parameter 017

	VLT 5000 series	FC 302 series
Parameter	018 Lock for data change	0-61 Access to Main Menu w/o Password
Options	[0] Not locked	[0] Full access
	[1] Lock	[1] LCP: Read only

Table 5.16 Conversion of Parameter 018

	VLT 5000 series	FC 302 series
Parameter	019 Power-Up Mode	0-04 Operating State at Power-up (Hand)
Options	[0] Auto Restart, use saved ref.	[0] Resume
	[1] Forced stop, use saved ref.	[1] Forced stop, use saved ref.
	[2] Forced stop, set ref = 0.	[2] Forced stop, set ref = 0

Table 5.17 Conversion of Parameter 019

	VLT 5000 series	FC 302 series
Parameter	027 Warning readout line	Not converted
Options	[0] Warning in line 1/2	
	[1] Warning in line 3/4	

Table 5.18 Conversion of Parameter 027

## 5.2 VLT® 5000 Parameter Group 1

	VLT 5000 series	FC 302 series
Parameter	100 Configuration	0-02 1-01 Motor Control Principle
Options	[0] Speed control, open loop	Par. 1-00 = [0] Speed open loop Par. 1-01 = [1] VVC <sup>plus</sup>
	[1] Speed control, closed loop	Par. 0-02 = [0] RPM Par. 1-00 = [1] Speed closed loop
	[3] Process control, closed loop	Par. 1-00 = [3] Process Par. 1-01 = [1] VVC <sup>plus</sup>
	[4] Torque control, open loop	Par. 1-00 = [4] Torque open loop Par.1-01 = [1] VVC <sup>plus</sup>
	[5] Torque control, speed feedback	Par. 1-00 = [2] Torque close loop Par. 1-01 = [3] Flux with motor fb Par. 5-71 = [1] Counter clockwise

Table 5.19 Conversion of Parameter 100

	VLT 5000 series	FC 302 series
Parameter	101 Torque characteristic	1-03 Torque Characteristics 1-04 Overload Mode 14-40 VT Level
Options	[1] High constant torque	Par. 1-03 = [0] Constant torque Par. 1-04 Over load = [0] High
	[2] High variable torque low	Par. 1-03 = [1] Variable torque Par. 14-40 VT level = 45% Par. 1-04 Over load = [0] High
	[3] High variable torque medium	Par. 1-03 = [1] Variable torque Par. 14-40 VT level = 66% Par. 1-04 Over load = [0] High
	[4] High variable torque high	Par. 1-03 = [1] Variable torque Par. 14-40 VT level = 85% Par. 1-04 Over load = [0] High
	[5] High special motor characteristic	Par. 1-01 = [0] U/f Par. 1-04 Over load = [0] High
	[6] High variable torque with low starting torque	Par. 1-03 = [1] Variable torque Par. 14-40 VT level = 45% Par. 1-04 Over load = [0] High

Table 5.20 Conversion of Parameter 101



	VLT 5000 series	FC 302 series
Parameter	101 Torque characteristic	1-03 Torque Characteristics 1-04 Overload Mode 14-40 VT Level
Options	[7] High variable torque with medium starting torque	Par. 1-03 = [1] Variable torque Par. 14-40 VT level = 66% Par. 1-04 Over load = [0] High
	[8] High variable torque with high starting torque	Par. 1-03 = [1] Variable torque Par. 14-40 VT level = 85% Par. 1-04 Over load = [0] High
	[11] Normal constant torque	Par. 1-03 = [0] Constant torque Par. 1-04 Over load = [1] Normal
	[12] Normal variable torque low	Par. 1-03 = [1] Variable torque Par. 14-40 VT level = 45% Par. 1-04 Over load = [1] Normal
	[13] Normal variable torque medium	Par. 1-03 = [1] Variable torque Par. 14-40 VT level = 66% Par. 1-04 Over load = [1] Normal
	[14] Normal variable torque high	Par. 1-03 = [1] Variable torque Par. 14-40 VT level = 85% Par. 1-04 Over load = [1] Normal
	[15] Normal special motor characteristic	Par. 1-01 = [0] U/f Par. 1-04 Over load = [1] Normal
	[16] Normal variable torque with low constant starting torque	Par. 1-03 = [1] Variable torque Par. 14-40 VT level = 45% Par. 1-04 Over load = [1] Normal
	[17] Normal variable torque with medium constant starting torque	Par. 1-03 = [1] Variable torque Par. 14-40 VT level = 66% Par. 1-04 Over load = [1] Normal
[18] Normal variable torque with high constant starting torque	Par. 1-03 = [1] Variable torque Par. 14-40 VT level = 85% Par. 1-04 Over load = [1] Normal	

Table 5.21 Conversion of Parameter 101

	VLT 5000 series	FC 302 series
Parameter	102 Motor Power	1-20 Motor Power [kW]
Range	0.18 – 600 kW	0.09 – 3000 kW

Table 5.22 Conversion of Parameter 102

	VLT 5000 series	FC 302 series
Parameter	103 Motor Voltage	1-22 Motor Voltage
Range	200 – 600 Volt	50 – 1000 V

Table 5.23 Conversion of Parameter 103

	VLT 5000 series	FC 302 series
Parameter	104 Motor frequency	1-23 Motor Frequency
Range	20 -1000 Hz	20 -1000 Hz

Table 5.24 Conversion of Parameter 104

	VLT 5000 series	FC 302 series
Parameter	105 Motor Current	1-24 Motor Current
Range	Power Unit dependable	Power Unit dependable

Table 5.25 Conversion of Parameter 105

	VLT 5000 series	FC 302 series
Parameter	106 Rated motor speed	1-25 Motor Nominal Speed
Range	100 – 60000	10 – 60000

Table 5.26 Conversion of Parameter 106

	VLT 5000 series	FC 302 series
Parameter	107 Automatic motor adaptation	1-29 Automatic Motor Adaptation (AMA)
Options	[0] Adaptation off	[0] Off
	[1] Adaptation on, Rs and Xs	[1] Enable complete AMA
	[2] Adaptation on, RS	[2] Enable reduce AMA

Table 5.27 Conversion of Parameter 107

	VLT 5000 series	FC 302 series
Parameter	108 Stator resistor	1-30 Stator Resistance (Rs)
Range	Power Unit dependable	0.0140 – 140.0000

Table 5.28 Conversion of Parameter 108

	VLT 5000 series	FC 302 series
Parameter	109 Stator reactance	1-35 Main Reactance (Xh)
Range	Power Unit dependable	1.0000 – 10000.0000

Table 5.29 Conversion of Parameter 109

	VLT 5000 series	FC 302 series
Parameter	110 Motor magnetizing at 0 RPM	1-50 Motor Magnetisation at Zero Speed
Range	0 – 300%	0 – 300%

Table 5.30 Conversion of Parameter 110

	VLT 5000 series	FC 302 series
Parameter	111 Min. frequency normal magnetizing	1-52 Min Speed Normal Magnetising [Hz]
Range	0.1 – 10.0 Hz	0.3 – 10.0 Hz

Table 5.31 Conversion of Parameter 111

	VLT 5000 series	FC 302 series
Parameter	113 Load compensation at low speed	1-60 Low Speed Load Compensation
Range	0 – 300%	0 – 300%

Table 5.32 Conversion of Parameter 113

	VLT 5000 series	FC 302 series
Parameter	114 Load compensation at high speed	1-61 High Speed Load Compensation
Range	0 – 300%	0 – 300%

Table 5.33 Conversion of Parameter 114

	VLT 5000 series	FC 302 series
Parameter	115 Slip Compensation	1-62 Slip Compensation
Range	-500 - 500%	-500 - 500%

Table 5.34 Conversion of Parameter 115

	VLT 5000 series	FC 302 series
Parameter	116 Slip Compensation Time constant	1-63 Slip Compensation Time Constant
Range	0.05 – 1.00 s	0.05 – 5.00 s

Table 5.35 Conversion of Parameter 116

	VLT 5000 series	FC 302 series
Parameter	117 Resonance dampening	1-64 Resonance Damping
Range	0 - 500%	0 - 500%

Table 5.36 Conversion of Parameter 117

	VLT 5000 series	FC 302 series
Parameter	118 Resonance dampening time constant	1-65 Resonance Damping Time Constant
Range	5 – 50 ms	5 – 50 ms

Table 5.37 Conversion of Parameter 118

	VLT 5000 series	FC 302 series
Parameter	119 High starting torque	Not converted

Table 5.38 Conversion of Parameters 119

	VLT 5000 series	FC 302 series
Parameter	120 Start delay	1-71 Start Delay
Option	0.0 – 10.0 s	0.0 – 10.0 s

Table 5.39 Conversion of Parameter 120

	VLT 5000 series	FC 302 series
Parameter	121 Start function	1-72 Start Function
Options	[0] DC hold in start delay time	[0] DC hold/delay time
	[1] DC brake in start delay time	[1] DC Brake/delay time
	[2] Coasting in start delay time	[2] Coast/delay time
	[3] Start frequency/voltage clockwise	[3] Start speed cw
	[4] Start frequency/voltage in reference direction	[4] Horizontal operation
	[5] VVC <sup>plus</sup> clockwise	[5] VVC <sup>plus</sup> /Flux clockwise

Table 5.40 Conversion of Parameter 121

	VLT 5000 series	FC 302 series
Parameter	122 Function at stop	1-80 Function at Stop
Options	[0] Coasting	[0] Coast
	[1] DC hold	[1] DC hold
	[2] Motor check	[2] Motor check
	[3] Pre-magnetizing	[3] Pre-magnetizing

Table 5.41 Conversion of Parameter 122

	VLT 5000 series	FC 302 series
Parameter	123 Min frequency for function at stop	1-82 Min Speed for Function at Stop [Hz]
Range	0.0 – 10.0 Hz	0.0 – 20.0 Hz

Table 5.42 Conversion of Parameter 123

	VLT 5000 series	FC 302 series
Parameter	124 DC holding current	2-00 DC Hold Current
Range	0 - 100%	0 - 160% (motor depending)

Table 5.43 Conversion of Parameter 124

	VLT 5000 series	FC 302 series
Parameter	125 DC braking current	2-01 DC Brake Current
Range	0 - 100%	0 – 160% P.U depending

Table 5.44 Conversion of Parameter 125

	VLT 5000 series	FC 302 series
Parameter	126 DC braking time	2-02 DC Braking Time
Range	0.0 – 60.0 s	0.0 – 60.0 s

Table 5.45 Conversion of Parameter 126

	VLT 5000 series	FC 302 series
Parameter	127 DC brake cut-in frequency	2-04 DC Brake Cut In Speed [Hz]
Range	0.0 (Off) – $f_{max}$ (par. 202)	0.0 (Off) – $f_{max}$ (par. 414)

Table 5.46 Conversion of Parameter 127

	VLT 5000 series	FC 302 series
Parameter	128 Motor thermal protection	1-90 Motor Thermal Protection
Options	[0] No protection	[0] No protection
	[1] Thermistor warning	[1] Thermistor warning
	[2] Thermistor trip	[2] Thermistor trip
	[3] ETR warning 1	[3] ETR warning 1
	[4] ETR trip 1	[4] ETR trip 1
	[5] ETR warning 2	[5] ETR warning 2
	[6] ETR trip 2	[6] ETR trip 2
	[7] ETR warning 3	[7] ETR warning 3
	[8] ETR trip 3	[8] ETR trip 3
	[9] ETR warning 4	[9] ETR warning 4
	[10] ETR trip 4	[10] ETR trip 4

Table 5.47 Conversion of Parameter 128

	VLT 5000 series	FC 302 series
Parameter	129 External motor fan	1-91 Motor External Fan
Options	[0] No	[0] No
	[1] Yes	[1] Yes

Table 5.48 Conversion of Parameter 129

	VLT 5000 series	FC 302 series
Parameter	130 Start frequency	1-75 Start Speed [Hz]
Range	0.0 – 10.0 Hz	0.0 – 500 Hz P.U depending

Table 5.49 Conversion of Parameter 130

	VLT 5000 series	FC 302 series
Parameter	131 Initial voltage	Not converted

Table 5.50 Conversion of Parameter 131

	VLT 5000 series	FC 302 series
Parameter	145 Minimum DC brake time	Not converted

Table 5.51 Conversion of Parameter 132

## 5.3 VLT® 5000 Parameter Group 2

5

	VLT 5000 series	FC 302 series
Parameter	200 Output Frequency Range/ Direction	4-10 Motor Speed Direction
Options	[0] Only clockwise, 0 – 132 Hz	[0] Clockwise
	[1] Both directions, 0 – 132 Hz	[2] Both directions
	[2] Only clockwise, 0 – 1000 Hz	[0] Clockwise
	[3] Both directions, 0 – 1000 Hz	[2] Both directions
	[4] Only counter clockwise, 0 – 132 Hz	[1] Counter clockwise
	[5] Only counter clockwise, 0 – 1000 Hz	[1] Counter clockwise

Table 5.52 Conversion of Parameter 200

	VLT 5000 series	FC 302 series
Parameter	201 Output frequency low limit	4-12 Motor Speed Low Limit [Hz]
Range	0.0 – par. 202 F <sub>max</sub>	0 – par. 414 F <sub>max</sub> [Hz]

Table 5.53 Conversion of Parameter 201

	VLT 5000 series	FC 302 series
Parameter	202 Output frequency high limit	4-14 Motor Speed High Limit [Hz] 4-19 Max Output Frequency
Range	0.0 – 132/1000 Hz	0 – 1000 Hz

Table 5.54 Conversion of Parameter 202

	VLT 5000 series	FC 302 series
Parameter	203 Reference/feedback area	3-00 Reference Range
Options	[0] Min – Max	[0] Min – Max
	[1] - Max - +Max	[1] - Max - +Max

Table 5.55 Conversion of Parameter 203

	VLT 5000 series	FC 302 series
Parameter	204 Minimum reference	3-02 Minimum Reference
Range	-100,000.000 – par. 205 Ref <sub>max</sub>	-100,000.000 – par. 3-03 Ref <sub>max</sub>

Table 5.56 Conversion of Parameter 204

	VLT 5000 series	FC 302 series
Parameter	205 Maximum reference	3-03 Maximum Reference 6-15 Terminal 53 High Ref./Feedb. Value 6-25 Terminal 54 High Ref./Feedb. Value 5-53 Term. 29 High Ref./Feedb. Value 5-58 Term. 33 High Ref./Feedb. Value
Range	Par. 204 Ref <sub>min</sub> – 100,000.000	Par. 3-02 Ref <sub>min</sub> – 100,000.000

Table 5.57 Conversion of Parameter 205

	VLT 5000 series	FC 302 series
Parameter	206 Ramp Type	3-40 Ramp 1 Type 3-50 Ramp 2 Type 3-82 Quick Stop Ramp Type
Options	[0] Linear	Par. 3-40 = [0] Linear Par. 3-50 = [0] Linear Par. 3-82 = [0] Linear
	[1] Sine shape (S1)	Par. 3-40 = [2] S-ramp Const Time Par. 3-45 = 1% Par. 3-46 = 25% Par. 3-47 = 1% Par. 3-48 = 25% Par. 3-50 = [2] S-ramp Const Time Par. 3-55 = 1% Par. 3-56 = 25% Par. 3-57 = 1% Par. 3-58 = 25% Par. 3-82 = [2] S-ramp Const Time Par. 3-83 = 1% Par. 3-84 = 25%
	[2] Sin2 Shape (S2)	Par. 3-40 = [2] S-ramp Const Time Par. 3-45 = 25% Par. 3-46 = 25% Par. 3-47 = 25% Par. 3-48 = 25% Par. 3-50 = [2] S-ramp Const Time Par. 3-55 = 25% Par. 3-56 = 25% Par. 3-57 = 25% Par. 3-58 = 25% Par. 3-82 = [2] S-ramp Const Time Par. 3-83 = 25% Par. 3-84 = 25%

Table 5.58 Conversion of Parameter 206

	VLT 5000 series	FC 302 series
Parameter	206 Ramp Type	3-40 Ramp 1 Type3-50 Ramp 2 Type3-82 Quick Stop Ramp Type
Options	[0] Linear	[0] Linear. Write to p.340, 350 and 382
	[3] Sin3 Shape (S3)	Par. 3-40 = [2] S-ramp Const Time Par. 3-45 = 50% Par. 3-46 = 50% Par. 3-47 = 50% Par. 3-48 = 50% Par. 3-50 = [2] S-ramp Const Time Par. 3-55 = 50% Par. 3-56 = 50% Par. 3-57 = 50% Par. 3-58 = 50% Par. 3-82 = [2] S-ramp Const Time Par. 3-83 = 50% Par. 3-84 = 50%
	[4] Sin2 filter	Par. 3-40 = [2] S-ramp Const Time Par. 3-45 = 25% Par. 3-46 = 25% Par. 3-47 = 25% Par. 3-48 = 25% Par. 3-50 = [2] S-ramp Const Time Par. 3-55 = 25% Par. 3-56 = 25% Par. 3-57 = 25% Par. 3-48 = 25% Par. 3-82 = [2] S-ramp Const Time Par. 3-83 = 25% Par. 3-84 = 25%

Table 5.59 Conversion of Parameter 206

	VLT 5000 series	FC 302 series
Parameter	207 Ramp up Time 1	3-41 Ramp 1 Ramp Up Time
Range	0.05 – 3600.00 s	0.01 – 3600.00 s

Table 5.60 Conversion of Parameter 207

	VLT 5000 series	FC 302 series
Parameter	208 Ramp down Time 1	3-42 Ramp 1 Ramp Down Time
Range	0.05 – 3600.00 s	0.01 – 3600.00 s

Table 5.61 Conversion of Parameter 208

	VLT 5000 series	FC 302 series
Parameter	209 Ramp up Time 2	3-51 Ramp 2 Ramp Up Time
Range	0.05 – 3600.00 s	0.01 – 3600.00 s

Table 5.62 Conversion of Parameter 209

	VLT 5000 series	FC 302 series
Parameter	210 Ramp down Time 2	3-52 Ramp 2 Ramp Down Time
Range	0.05 – 3600.00 s	0.01 – 3600.00 s

Table 5.63 Conversion of Parameter 210

	VLT 5000 series	FC 302 series
Parameter	211 Jog ramp time	3-80 Jog Ramp Time
Range	0.05 – 3600.00 s	0.01 – 3600.00 s

Table 5.64 Conversion of Parameter 211

	VLT 5000 series	FC 302 series
Parameter	212 Quick stop ramp time	3-81 Quick Stop Ramp Time
Range	0.05 – 3600.00 s	0.01 – 3600.00 s

Table 5.65 Conversion of Parameter 212

	VLT 5000 series	FC 302 series
Parameter	213 Jog Frequency	3-11 Jog Speed [Hz]
Range	0.0 – par. 202	0.0 – par. 4-14

Table 5.66 Conversion of Parameter 213

	VLT 5000 series	FC 302 series
Parameter	214 Reference function	3-04 Reference Function
Options	[0] Sum	[0] Sum
	[1] Relative	See comment below*
	[2] External/Preset	[2] External/Preset

Table 5.67 Conversion of Parameter 214

\*= Relative reference is added to the MRV from PROFIBUS.

	VLT 5000 series	FC 302 series
Parameter	215 Preset Reference 1	3-10 Preset Reference
Range	-100.00 – 100.00%	-100.00 – 100.00%

Table 5.68 Conversion of Parameter 215

	VLT 5000 series	FC 302 series
Parameter	216 Preset Reference 2	3-10 Preset Reference
Range	-100.00 – 100.00%	-100.00 – 100.00%

Table 5.69 Conversion of Parameter 216

	VLT 5000 series	FC 302 series
Parameter	217 Preset Reference 3	3-10 Preset Reference
Range	-100.00 – 100.00%	-100.00 – 100.00%

Table 5.70 Conversion of Parameter 217

	VLT 5000 series	FC 302 series
Parameter	218 Preset Reference 4	3-10 Preset Reference
Range	-100,00 - 100,00%	-100,00 - 100,00%

Table 5.71 Conversion of Parameter 218

	VLT 5000 series	FC 302 series
Parameter	219 Catch up/slow down value	3-12 Catch up/slow Down Value
Range	0.00 – 100%	0.00 – 100%

Table 5.72 Conversion of Parameter 219

	VLT 5000 series	FC 302 series
Parameter	221 Torque limit for motor mode	4-16 Torque Limit Motor Mode
Range	0.0 – Max. torque %	0.0 – Max. torque %

Table 5.73 Conversion of Parameter 221

	VLT 5000 series	FC 302 series
Parameter	222 Torque limit for generating mode	4-17 Torque Limit Generator Mode
Range	0.0 – Max. torque %	0.0 – Max. torque %

Table 5.74 Conversion of Parameter 222

	VLT 5000 series	FC 302 series
Parameter	223 Warning: Current Low	4-50 Warning Current Low 2-20 Release Brake Current
Range	0.0 – par. 2-24 Current High	0.00 – par. 4-51

Table 5.75 Conversion of Parameter 223

	VLT 5000 series	FC 302 series
Parameter	224 Warning: Current High	4-51 Warning Current High
Range	Power Unit dependable	Power Unit dependable

Table 5.76 Conversion of Parameter 224

	VLT 5000 series	FC 302 series
Parameter	225 Warning Low Frequency	4-52 Warning Speed Low 2-22 Activate Brake Speed [Hz]
Range	0,0 – par. 226	0,0 – Par. 4-53

Table 5.77 Conversion of Parameter 225

	VLT 5000 series	FC 302 series
Parameter	226 Warning High Frequency	4-53 Warning Speed High
Range	par. 2-25 – par. 202	Par. 4-52 – par. 4-13

Table 5.78 Conversion of Parameter 226

	VLT 5000 series	FC 302 series
Parameter	227 Warning Low Feedback	4-56 Warning Feedback Low
Range	-100,000.000 – par. 228	-999,999.999 – par. 4-57

Table 5.79 Conversion of Parameter 227

	VLT 5000 series	FC 302 series
Parameter	228 Warning High Feedback	4-57 Warning Feedback High
Range	par. 227 – 100,000.000	Par. 4-56 – 999,999.999

Table 5.80 Conversion of Parameter 228

	VLT 5000 series	FC 302 series
Parameter	229 Frequency bypass, bandwidth	Stored in EEprom only
Range	0 - 100%	

Table 5.81 Conversion of Parameter 229

	VLT 5000 series	FC 302 series
Parameter	230 Frequency Bypass 1	4-61 Bypass Speed From [Hz] 4-63 Bypass Speed To [Hz]
Range	0 – par. 200	0 – par. 4-14

Table 5.82 Conversion of Parameter 230

	VLT 5000 series	FC 302 series
Parameter	2-31 Frequency Bypass 2	4-61 Bypass Speed From [Hz] 4-63 Bypass Speed To [Hz]
Range	0 – par. 200	0 – par. 4-14

Table 5.83 Conversion of Parameter 231

	VLT 5000 series	FC 302 series
Parameter	232 Frequency Bypass 3	4-61 Bypass Speed From [Hz] 4-63 Bypass Speed To [Hz]
Range	0 – par. 200	0 – par. 4-14

Table 5.84 Conversion of Parameter 232

	VLT 5000 series	FC 302 series
Parameter	233 Frequency Bypass 4	4-61 Bypass Speed From [Hz] 4-63 Bypass Speed To [Hz]
Range	0 – par. 200	0 – par. 4-14

Table 5.85 Conversion of Parameter 233

	VLT 5000 series	FC 302 series
Parameter	234 Motor phase monitor	4-58 Missing Motor Phase Function
Range	[0] Enable [1] Disable	[2] Trip 1000 ms [0] Disable

Table 5.86 Conversion of Parameter 234

## 5.4 VLT® 5000 Parameter Group 3

	VLT 5000 series	FC 302 series
Parameter	300 Terminal 16, input	5-16 Terminal X30/2 Digital Input
Options	[0] No function	[0] No function
	[1] Reset	[1] Reset
	[2] Stop inverse	[6] Stop inverse
	[3] Only start clockwise, on	[12] Enable start forward on
	[4] Jog	[14] Jog
	[5] Preset reference, on	[15] Preset reference, on
	[6] Preset reference, lsb	[16] Preset reference bit 0
	[7] Freeze reference	[17] Freeze reference
	[8] Freeze output	[20] Freeze output
	[9] Speed up	[21] Speed up
	[10] Choice of setup, lsb	[23] Setup select bit 0
	[11] Catch-up	[28] Catch-up
	[12] Ramp 2	[34] Ramp bit 0
[13] Mains failure inverted	Not supported	
[29] Data change lock	Not supported	
Comments	FC 300 does not have a digital input 16, so this is linked to <i>5-16 Terminal X30/2 Digital Input</i>	

Table 5.87 Conversion of Parameter 300

	VLT 5000 series	FC 302 series
Parameter	301 Terminal 17, input	5-17 Terminal X30/3 Digital Input
Options	[0] No function	[0] No operation
	[1] Reset	[1] Reset
	[2] Stop inverse	[6] Stop inverse
	[3] Only start anticlockwise, on	[13] Enable start reverse on
	[4] Jog	[14] Jog
	[5] Preset reference, on	[15] Preset reference, on
	[6] Preset reference, msb	[17] Preset reference bit 1
	[7] Freeze reference	[19] Freeze reference
	[8] Freeze output	[20] Freeze output
	[9] Speed down	[22] Speed down
	[10] Choice of setup, msb	[24] Setup select bit 1
	[11] Slow down	[29] Slow down
	[12] Ramp 2	[34] Ramp bit 0
[13] Mains failure inverted	Not supported	
[23] Pulse reference	[32] Pulse input	
[24] Safety interlock	Not supported	
[29] Data change lock	Not supported	
Comments	FC 300 does not have a digital input 17, so this is linked to <i>5-16 Terminal X30/2 Digital Input</i>	

Table 5.88 Conversion of Parameter 301

	VLT 5000 series	FC 302 series
Parameter	302 Terminal 18, input	5-10 Terminal 18 Digital Input
Options	[0] No function	[0] No operation
	[1] Start	[8] Start
	[2] Latched start	[9] Latched start
	[3] Only start clockwise, on	[12] Enable start forward on

Table 5.89 Conversion of Parameter 302

	VLT 5000 series	FC 302 series
Parameter	303 Terminal 19, input	5-11 Terminal 19 Digital Input
Options	[0] No function	[0] No operation
	[1] Reversing	[10] Reversing
	[2] Start reversing	[11] Start reversing
	[3] Only start anticlockwise, on	[13] Enable start reverse

Table 5.90 Conversion of Parameter 303

	VLT 5000 series	FC 302 series
Parameter	304 Terminal 27, input	5-12 Terminal 27 Digital Input
Options	[0] Coasting stop, inverse	[2] Coast inverse
	[1] Reset and Coasting stop, inv.	[3] Coast and reset inv
	[2] Quick-stop, inverse	[4] Quick-stop, inverse
	[3] DC-braking, inverse	[5] DC-brake inverse
	[4] Stop inverse	[6] Stop inverse

Table 5.91 Conversion of Parameter 304

	VLT 5000 series	FC 302 series
Parameter	305 Terminal 29, input	5-13 Terminal 29 Digital Input
Options	[0] No function	[0] No operation
	[1] Reset	[1] Reset
	[2] Stop inverse	[6] Stop inverse
	[3] Only start clockwise, on	[12] Enable start forward
	[4] Only start anticlockwise, on	[13] Enable start reverse
	[5] Jog	[14] Jog
	[6] Preset reference, on	[15] Preset reference, on
	[7] Preset reference, lsb	[16] Preset reference bit 0
	[8] Preset reference, msb	[17] Preset reference bit 1
	[9] Freeze reference	[19] Freeze reference
	[10] Freeze output	[20] Freeze output
	[11] Speed up	[21] Speed up
	[12] Speed down	[22] Speed down
	[13] Choice of Setup, lsb	[23] Setup select bit 0
	[14] Choice of Setup, msb	[24] Setup select bit 1
	[15] Catch up	[28] Catch up
	[16] Slow down	[29] Slow down
	[17] Ramp 2	[34] Ramp bit 0
	[18] Mains failure inverted	Not supported
	[28] Pulse reference	[32] Pulse input
[29] Data change lock	Not supported	

Table 5.92 Conversion of Parameter 305

	VLT 5000 series	FC 302 series
Parameter	306 Terminal 32, input	5-14 Terminal 32 Digital Input
Options	[0] No function	[0] No operation
	[1] Reset	[1] Reset
	[2] Stop inverse	[6] Stop inverse
	[3] Only start clockwise, on	[12] Enable start forward
	[4] Jog	[14] Jog
	[5] Preset reference, on	[15] Preset reference, on
	[6] Preset reference, lsb	[16] Preset reference bit 0
	[7] Freeze reference	[19] Freeze reference
	[8] Freeze output	[20] Freeze output
	[9] Speed up	[21] Speed up
	[10] Choice of Setup, lsb	[23] Setup select bit 0
	[11] Choice of Setup, msb / Speed up	Not supported
	[12] Catch up	[28] Catch up
	[13] Ramp 2	[34] Ramp bit 0
	[14] Mains failure inverted	Not supported
	[24] Encoder input 2A	[0] No operation
	[29] Data change lock	Not supported

Table 5.93 Conversion of Parameter 306

	VLT 5000 series	FC 302 series
Parameter	307 Terminal 33, input	5-15 Terminal 33 Digital Input 7-00 Speed PID Feedback Source
Options	[0] No function	[0] No operation
	[1] Reset	[1] Reset
	[2] Stop inverse	[6] Stop inverse
	[3] Only start anticlockwise, on	[13] Enable start reverse
	[4] Jog	[14] Jog
	[5] Preset reference, on	[15] Preset reference, on
	[6] Preset reference, msb	[17] Preset reference bit 1
	[7] Freeze reference	[19] Freeze reference
	[8] Freeze output	[20] Freeze output
	[9] Speed down	[22] Speed down
	[10] Choice of Setup, msb	[24] Setup select bit 1
	[11] Choice of Setup, msb / Speed down	Not supported
	[12] Slow down	[29] Slow down
	[13] Ramp 2	[34] Ramp bit 0
	[14] Mains failure inverted	Not supported
	[24] Pulse feedback	[32] Pulse input, Parameter 700 = [9] Frequency input 33
	[25] Encoder input 2B	[0] No operation Parameter 700 = [1] 24 V encoder
	[29] Data change lock	Not supported

Table 5.94 Conversion of Parameter 307



	VLT 5000 series	FC 302 series
Parameter	308 Terminal 53, Analogue Input Voltage	3-15 Reference Resource 1 7-00 Speed PID Feedback Source 1-93 Thermistor Resource 4-20 Torque Limit Factor Source
Options	[0] No Operation	Par. 3-15 Reference resource 1 set to [0] No function
	[1] Reference	Par. 3-15 Reference resource 1 set to [1] Analog input 53
	[2] Feedback signal	Par. 3-15 Reference resource 1 set to [1] Analog input 53 Par. 7-00 Speed PID Feedback Source set to [6] Analog input 53
	[3] Torque limit	Par. 3-15 Reference resource 1 set to [1] Analog input 53 Par. 4-20 Torque Limit Factor Source set to [2] Analog in 53
	[4] Thermistor	Par. 3-15 Reference resource 1 set to [0] No function Par. 1-93 Thermistor Ressource set to [1] Analog input 53

Table 5.95 Conversion of Parameter 308

	VLT 5000 series	FC 302 series
Parameter	309 Terminal 53, min. scaling	6-10 Terminal 53 Low Voltage
Range	0 – 10.0 Volt	-10.00 – Par. 6-11

Table 5.96 Conversion of Parameter 309

	VLT 5000 series	FC 302 series
Parameter	310 Terminal 53, max. scaling	6-11 Terminal 53 High Voltage
Range	0 – 10.0 Volt	Par. 6-10 - 10.00 Volt

Table 5.97 Conversion of Parameter 310

	VLT 5000 series	FC 302 series
Parameter	311 Terminal 54, Analogue Input Voltage	3-16 Reference Resource 2 7-00 Speed PID Feedback Source 4-20 Torque Limit Factor Source 1-93 Thermistor Resource 4-21 Speed Limit Factor Source
Options	[0] No Operation	Par. 3-16 Reference resource 2 set to [0] No function
	[1] Reference	Par. 3-16 Reference resource 1 set to [2] Analog input 53
	[2] Torque limit	Par. 4-20 Torque Limit Factor Source set to [6] Analog in 54
	[3] Thermistor	Par. 1-93 Thermistor Ressource set to [2] Analog input 54
	[4] Relative reference	Not supported
	[5] Max. torque frequency	Par. 4-21 Speed Limit Factor Source set to [6] Analog in 54

Table 5.98 Conversion of Parameter 311

	VLT 5000 series	FC 302 series
Parameter	312 Terminal 54, min. scaling	6-20 Terminal 54 Low Voltage
Range	0 – 10.0 Volt	-10.00 – Par. 6-21

Table 5.99 Conversion of Parameter 312

	VLT 5000 series	FC 302 series
Parameter	313 Terminal 54, max. scaling	6-21 Terminal 54 High Voltage
Range	0 – 10.0 Volt	Par. 6-20 - 10.00 Volt

Table 5.100 Conversion of Parameter 313

	VLT 5000 series	FC 302 series
Parameter	314 Terminal 60, Analogue Input current	3-17 Reference Resource 3 7-00 Speed PID Feedback Source 1-93 Thermistor Resource 4-20 Torque Limit Factor Source
Options	[0] No Operation	Par. 3-17 Reference resource 3 set to [0] No function
	[1] Reference	Par. 3-17 Reference resource 3 set to [2] Analog input 54 Par. 7-00 Speed PID Feedback Source set to [7] Analog input 54
	[2] Feedback signal	Par. 7-00 Speed PID Feedback Source set to [7] Analog input 54
	[3] Torque limit	Par. 3-17 Reference resource 3 set to [2] Analog input 54 Par. 4-20 Torque Limit Factor Source set to [6] Analog in 54
	[4] Relative reference	Not supported
Comments	The HW switch S202 for analogue input 54 must be set to current (ON).	

Table 5.101 Conversion of Parameter 314

	VLT 5000 series	FC 302 series
Parameter	315 Terminal 60, min. scaling	6-22 Terminal 54 Low Current
Range	0.0 – 20.0 mA	0.00 – Par. 6-23

Table 5.102 Conversion of Parameter 315

	VLT 5000 series	FC 302 series
Parameter	316 Terminal 60, max. scaling	6-23 Terminal 54 High Current
Range	0.0 – 20.0 mA	Par. 6-22 - 20.00 mA

Table 5.103 Conversion of Parameter 316

	VLT 5000 series	FC 302 series
Parameter	317 Time Out	6-00 Live Zero Timeout Time
Range	0 – 99 sec	0 – 99 sec

Table 5.104 Conversion of Parameter 317

	VLT 5000 series	FC 302 series
Parameter	318 Function after time out	6-01 Live Zero Timeout Function
Options	[0] Off	[0] Off
	[1] Freeze output frequency	[1] Freeze output frequency
	[2] Stop	[2] Stop
	[3] Jogging	[3] Jog
	[4] Max Speed, p202	[4] Max Speed
	[5] Stop and trip	[5] Stop and trip

Table 5.105 Conversion of Parameter 318

	VLT 5000 series	FC 302 series
Parameter	319 Terminal 42, Output	Digital = Par. 5-32 DO X30/7 (MCB 101) Analogue values = Par. 6-50 AO 42 Pulse = Par. 5-66 DO X30/6
Parameter	321 Terminal 45, Output	Digital = Par. 5-33 DO X30/7 (MCB 101) Analogue values= Par. 6-60 AO X30/8 Pulse = Par. 5-66 DO X30/6
Options	[0] No function	Par. 5-32 = [0] No operation
	[1] Control Ready	Par. 5-32 = [1] Control Ready
	[2] Ready signal	Par. 5-32 = [2] Drive ready
	[3] Ready - Remote Control	Par. 5-32 = [3] Drive rdy/rem ctrl
	[4] Enabled, no warning	Par. 5-32 = [4] Enable / no warning
	[5] Running	Par. 5-32 = [5] VLT® running
	[6] Running, no Warning	Par. 5-32 = [6] Running /no warning
	[7] Running within range, no Warning	Par. 5-32 = [7] Run in range/no warning
	[8] Run at reference, no Warning	Par. 5-32 = [8] Run on ref/no warning
	[9] Alarm	Par. 5-32 = [9] Alarm
	[10] Alarm or Warning	Par. 5-32 = [10] Alarm or Warning
	[11] Torque limit	Par. 5-32 = [11] At torque limit
	[12] Out of current range	Par. 5-32 = [12] Out of current range
	[13] Above I low	Par. 5-32 = [13] Below current, low <sup>1)</sup>
[14] Under I high	Par. 5-32 = [14] Above current, high <sup>1)</sup>	

Table 5.106 Conversion of Parameters 319 to 321

	VLT 5000 series	FC 302 series
Parameter	319 Terminal 42, Output	Digital = Par. 5-32 DO X30/7 (MCB 101) Analogue values= Par. 6-50 AO 42 Pulse = Par. 5-66 DO X30/6
Parameter	321 Terminal 45, Output	Digital = Par. 5-33 DO X30/7 (MCB 101) Analogue values= Par. 6-60 AO X30/8 Pulse = Par. 5-66 DO X30/6
Options	[15] Out of frequency range	Par. 5-32 = [15] Out of speed range
	[16] Over f low	Par. 5-32 = [16] Below speed low <sup>1)</sup>
	[17] Under f high	Par. 5-32 = [17] Above speed high <sup>1)</sup>
	[18] Out of feedback range	Par. 5-32 = [18] Out of feedb. Range
	[19] Over feedback low	Par. 5-32 = [19] Below feedback low <sup>1)</sup>
	[20] Under feedback high	Par. 5-32 = [20] Above feedback high <sup>1)</sup>
	[21] Thermal warning	Par. 5-32 = [21] Thermal warning
	[22] Ready, no thermal warning	Par. 5-32 = [12] Ready, no thermal W
	[23] Ready - remote control - no thermal warning	Par. 5-32 = [23] Remote, ready, no TW
	[24] Ready – mains voltage within range	Par. 5-32 = [24] Ready, Voltage OK
	[25] Reversing	Par. 5-32 = [25] Reverse
[26] Bus OK	Par. 5-32 = [26] Bus OK	
[27] Torque limit and stop	Par. 5-32 = [27] Torque limit & stop	

Table 5.107 Conversion of Parameters 319 to 321

	VLT 5000 series	FC 302 series
Parameter	319 Terminal 42, Output	Digital = Par. 5-32 DO X30/7 (MCB 101) Analogue values= Par. 6-50 AO 42 Pulse = Par. 5-66 DO X30/6
Parameter	321 Terminal 45, Output	Digital = Par. 5-33 DO X30/7 (MCB 101) Analogue values= Par. 6-60 AO X30/8 Pulse = Par. 5-66 DO X30/6
Options	[28] Brake, no brake warning	Par. 5-32 = [28] Brake, no brake warning
	[29] Brake ready, no fault	Par. 5-32 = [29] Brake ready, no fault
	[30] Brake fault	Par. 5-32 = [30] Brake fault (IGBT)
	[31] Relay 123	Par. 5-32 = [31] Relay 123
	[32] Mechanical brake control	Par. 5-32 = [32] Mech brake ctrl
	[34] Extended mechanical brake control	Par. 5-32 = [32] Mech brake ctrl
	[35] Safety Interlock	Not supported
	[36] 0 – 100 Hz ⇒ 0 – 20 mA	Not supported
	[37] 0 – 100 Hz ⇒ 4 – 20 mA	Not supported
	[38] 0 – 100 Hz ⇒ 0 – 32000 p	Not supported
	[39] 0 – f max ⇒ 0 – 20 mA	Par. 6-50 = [109] Max Out freq. 0 – 20 mA
	[40] 0 – f max ⇒ 4 – 20 mA	Par. 6-50 = [130] Max Out freq. 4 – 20 mA
	[41] 0 – f max ⇒ 0 – 32000 p	Par. 5-66 = [109] Max Out freq. 0 – 32000p Par. 568 = 32000
	[42] Ref min – Ref max ⇒ 0 – 20 mA	Par. 6-50 = [101] Reference 0 -20 mA

Table 5.108 Conversion of Parameters 319 to 321

	VLT 5000 series	FC 302 series
Parameter	319 Terminal 42, Output	Digital = Par. 5-32 DO X30/7 (MCB 101) Analogue values= Par. 6-50 AO 42 Pulse = Par. 5-66 DO X30/6
Parameter	321 Terminal 45, Output	Digital = Par. 5-33 DO X30/7 (MCB 101) Analogue values= Par. 6-60 AO X30/8 Pulse = Par. 5-66 DO X30/6
Options	[43] Ref min – Ref max ⇒ 4 – 20 mA	Par. 6-50 = [131] Reference 4 -20 mA
	[44] Ref min – Ref max ⇒ 0 – 32000 p	Par. 5-66 = [101] Reference 0 – 32000p Par. 5-68 = 32000
	[45] FB min – FB max ⇒ 0 – 20 mA	Par. 6-50 = [102] Feedback 0 -20 mA
	[46] FB min – FB max ⇒ 4 – 20 mA	Par. 6-50 = [132] Feedback 4 -20 mA
	[47] FB min – FB max ⇒ 0 – 32000 p	Par. 5-66 = [102] Feedback 0 – 32000p Par. 5-68 = 32000
	[48] 0 – I max ⇒ 0 – 20 mA	Par. 6-50 = [103] Motor current 0 -20 mA
	[49] 0 – I max ⇒ 4 – 20 mA	Par. 6-50 = [133] Motor current 4 -20 mA
	[50] 0 – I max ⇒ 0 – 32000 p	Par. 5-66 = [103] Motor current 0 - 32000p Par. 5-68 = 32000
	[51] 0 – T lim ⇒ 0 – 20 mA	Par. 6-50 = [104] Torque related to limit 0 - 20 mA
	[52] 0 – T lim ⇒ 4 – 20 mA	Par. 6-50 = [134] Torque related to limit 4 - 20 mA
	[53] 0 – T lim ⇒ 0 – 32000 p	Par. 5-66 = [104] Torque related to limit 0 – 32000p Par. 5-68 = 32000
	[54] 0 – T nom ⇒ 0 – 20 mA	Par. 6-50 = [105] Torque related to norm 0 - 20 mA
	[55] 0 – T nom ⇒ 4 – 20 mA	Par. 6-50 = [135] Torque related to norm 4 - 20 mA
	[56] 0 – T nom ⇒ 0 – 32000 p	Par. 5-66 = [105] Torque related to norm 0 – 32000p Par. 5-68 = 32000
[57] 0 – P nom ⇒ 0 – 20 mA	Par. 6-50 = [106] Power related to norm 0 - 20 mA	
[58] 0 – P nom ⇒ 4 – 20 mA	Par. 6-50 = [136] Power related to norm 4 - 20 mA	
[59] 0 – P nom ⇒ 0 – 32000 p	Par. 5-66 = [106] Power related to norm 0 – 32000p Par. 5-68 = 32000	

Table 5.109 Conversion of Parameters 319 to 321

	VLT 5000 series	FC 302 series
Parameter	319 Terminal 42, Output	Digital = Par. 5-32 DO X30/7 (MCB 101) Analogue values= Par. 6-50 AO 42 Pulse = Par. 5-66 DO X30/6
Parameter	321 Terminal 45, Output	Digital = Par. 5-33 DO X30/7 (MCB 101) Analogue values= Par. 6-60 AO X30/8 Pulse = Par. 5-66 DO X30/6
Options	[60] 0 – SyncRPM ⇒ 0 – 20 mA	Not supported
	[61] 0 – SyncRPM ⇒ 4 – 20 mA	Not supported
	[62] 0 – SyncRPM ⇒ 0 – 32000 p	Not supported
	[63] RPM at F max ⇒ 0 – 20 mA	Par. 6-50 = [107] Speed related to norm 0 - 20 mA
	[64] RPM at F max ⇒ 4 – 20 mA	Par. 6-50 = [137] Speed related to norm 4 - 20 mA
	[65] RPM at F max ⇒ 0 – 32000 p	Par. 5-66 = [107] Speed related to norm 0 – 32000p Par. 5-68 = 32000

Table 5.110 Conversion of Parameters 319 to 321

	VLT 5000 series	FC 302 series
Parameter	320 Terminal 42 Output, pulse scaling	5-68 Pulse Output Max Freq #X30/6
Range	1 – 32000 Hz	0 – 32000 Hz

Table 5.111 Conversion of Parameter 320

	VLT 5000 series	FC 302 series
Parameter	322 Terminal 45 Output, pulse scaling	5-68 Pulse Output Max Freq #X30/6
Range	1 – 32000 Hz	0– 32000 Hz

Table 5.112 Conversion of Parameter 322

	VLT 5000 series	FC 302 series
Parameter	323, 326	5-40 Function Relay
Range	01 Relay 04 Relay [0] No function [1] Control Ready [2] Ready signal [3] Ready - Remote Control [4] Enabled, no warning [5] Running [6] Running, no Warning [7] Running within range, no warning [8] Run at reference, no Warning [9] Alarm [10] Alarm or Warning [11] Torque limit [12] Out of current range [13] Above I low [14] Under I high [15] Out of frequency range [16] Over f low [17] Under f high [18] Out of feedback range [19] Over feedback low [20] Under feedback high [21] Thermal warning	Relay 1 Relay 2 Par. 5-40 = [0] No operation Par. 5-40 = [1] Control Ready Par. 5-40 = [2] Drive ready Par. 5-40 = [3] Drive rdy/rem ctrl Par. 5-40 = [4] Enable / no warning Par. 5-40 = [5] VLT running Par. 5-40 = [6] Running / no warning Par. 5-40 = [7] Run in range/no warn Par. 5-40 = [8] Run on ref/no warn Par. 5-40 = [9] Alarm Par. 5-40 = [10] Alarm or Warning Par. 5-40 = [11] At torque limit Par. 5-40 = [12] Out of current range Par. 5-40 = [13] Below current, low <sup>1)</sup> Par. 5-40 = [14] Above current, high <sup>1)</sup> Par. 5-40 = [15] Out of speed range Par. 5-40 = [16] Below speed low <sup>1)</sup> Par.5-40 = [17] Above speed high <sup>1)</sup> Par. 5-40 = [18] Out of feedb. Range Par. 5-40 = [16] Below feedback low <sup>1)</sup> Par. 5-40 = [17] Above feedback high <sup>1)</sup> Par. 5-40 = [21] Thermal warning

Table 5.113 Conversion of Parameters 323 to 326

	VLT 5000 series	FC 302 series
Parameter	323, 326	5-40 Function Relay
Range	[22] Ready, no thermal warning [23] Ready - remote control - no thermal warning [24] Ready – mains voltage within range [25] Reversing [26] Bus OK [27] Torque limit and stop [28] Brake, no brake warning [29] Brake ready, no fault [30] Brake fault [31] Relay 123 [32] Mechanical brake control [33] Control word bit 11/12 [34] Extended mechanical brake control [35] Safety Interlock	Par. 5-40 = [12] Ready,no thermal W Par. 5-40 = [23] Remote, ready, no TW Par. 5-40 = [24] Ready, Voltage OK Par. 5-40 = [25] Reverse Par. 5-40 = [26] Bus OK Par. 5-40 = [27] Torque limit & stop Par. 5-40 = [28] Brake, no brake warning Par. 5-40 = [29] Brake ready, no fault Par. 5-40 = [30] Brake fault (IGBT) Par. 5-40 = [31] Relay 123 Par. 5-40.0 = [32] Mech brake ctrl Par. 1-72 = [5] VVC+/Flux Par. 5-40 = [36] Control word bit 11 Par. 5-40.1 = [37] Control word bit 12 Par. 5-40.0 = [32] Mech brake ctrl Par. 1-72 = [5] VVC+/Flux Not supported

Table 5.114 Conversion of Parameters 323 to 326

	VLT 5000 series	FC 302 series
Parameter	324 Relay 01, ON delay	5-41 On Delay, Relay
Range	0.00 – 600.00 sec	0.01 – 600.00 sec

Table 5.115 Conversion of Parameter 324

	VLT 5000 series	FC 302 series
Parameter	325 Relay 01, OFF delay	5-42 Off Delay, Relay
Range	0.00 – 600.00 s	0.01 – 600.00 s

Table 5.116 Conversion of Parameter 325

	VLT 5000 series	FC 302 series
Parameter	327 Pulse reference, max. freq	5-51 Term. 29 High Frequency
Range	100 – 65000 Hz	0 – 110000 Hz

Table 5.117 Conversion of Parameter 327

	VLT 5000 series	FC 302 series
Parameter	328 Pulse feedback, max. freq	5-56, 5-50, 5-55
Range	100 – 65000 Hz	0 – 110000 Hz

Table 5.118 Conversion of Parameter 328

	VLT 5000 series	FC 302 series
Parameter	329 Encoder feedback pulse/rev.	5-70 Term 32/33 Pulses Per Revolution
Range	1 – 4096 pulses	1 – 4096 pulses

Table 5.119 Conversion of Parameter 329

	VLT 5000 series	FC 302 series
Parameter	330 Freeze ref. /output function	Not converted

Table 5.120 Conversion of Parameter 330

	VLT 5000 series	FC 302 series
Parameter	345 Encoder loss timeout	4-32 Motor Feedback Loss Timeout
Range	0.0 – 60.0 s	0.00 – 60.00 s

Table 5.121 Conversion of Parameter 345

	VLT 5000 series	FC 302 series
Parameter	346 Encoder loss function	4-30 Motor Feedback Loss Function
Range	[0] Off	[0] Disable
	[1] Freeze output frequency	[4] Freeze output frequency
	[3] Jog	[3] Jog
	[4] Max speed	[5] Max speed
	[5] Stop and trip	[11] Stop and trip
	[7] Select setup 4	[10] Select setup 4

Table 5.122 Conversion of Parameter 346

	VLT 5000 series	FC 302 series
Parameter	357 Term. 42, Output min. scale	6-51 Terminal 42 Output Min Scale
Range	0 – 100%	0 – 200%

Table 5.123 Conversion of Parameter 357

	VLT 5000 series	FC 302 series
Parameter	358 Term. 42, Output max. scale	6-52 Terminal 42 Output Max Scale
Range	0 – 500%	0 – 200%

Table 5.124 Conversion of Parameter 358

	VLT 5000 series	FC 302 series
Parameter	359 Term. 45, Output min. scale	6-61 Terminal X30/8 Min. Scale
Range	0 – 100%	0 – 200%

Table 5.125 Conversion of Parameter 359

	VLT 5000 series	FC 302 series
Parameter	360 Term. 45, Output max. scale	6-62 Terminal X30/8 Max. Scale
Range	0 – 500%	0 – 200%

Table 5.126 Conversion of Parameter 360

	VLT 5000 series	FC 302 series
Parameter	361 Encoder loss threshold	Not converted
Range	0 – 600%	

Table 5.127 Conversion of Parameter 361

### 5.5 VLT® 5000 Parameter Group 4

	VLT 5000 series	FC 302 series
Parameter	400 Brake function/over voltage cont.	2-10 Brake Function 2-17 Over-voltage Control
Options	[0] Off	[0] Off
	[1] Resistor brake	Par. 2-10 = *1* Resistor brake Par. 2-17 = [0] Off
	[2] Over voltage control	Par. 2-10 = [0] Off Par. 2-17 = [2] Enabled
	[3] Over voltage control and stop	Par. 2-10 = [0] Off Par. 2-17 = [1] Enabled (not at stop)

Table 5.128 Conversion of Parameter 400

	VLT 5000 series	FC 302 series
Parameter	401 Brake resistor, [Ω]	30-81 Brake Resistor (ohm)
Options	Power unit dependable	Power unit dependable

Table 5.129 Conversion of Parameter 401

	VLT 5000 series	FC 302 series
Parameter	402 Brake power limit, [kW]	2-12 Brake Power Limit (kW)
Range	Depends on unit	Depends on unit

Table 5.130 Conversion of Parameter 402

	VLT 5000 series	FC 302 series
Parameter	403 Power monitoring	2-13 Brake Power Monitoring
Options	[0] Off	[0] Off
	[1] Warning	[1] Warning
	[2] Trip	[2] Trip

Table 5.131 Conversion of Parameter 403

	VLT 5000 series	FC 302 series
Parameter	404 Brake check	2-15 Brake Check
Options	[0] Off	[0] Off
	[1] Warning	[1] Warning
	[2] Trip	[2] Trip

Table 5.132 Conversion of Parameter 404

	VLT 5000 series	FC 302 series
Parameter	405 Reset	14-20 Reset Mode
Options	[0] Manual reset	[0] Off
	[1] Automatic reset x 1	[1] Automatic reset x 1
	[2] Automatic reset x 2	[2] Automatic reset x 2
	[3] Automatic reset x 3	[3] Automatic reset x 3
	[4] Automatic reset x 4	[4] Automatic reset x 4
	[5] Automatic reset x 5	[5] Automatic reset x 5
	[6] Automatic reset x 6	[6] Automatic reset x 6
	[7] Automatic reset x 7	[7] Automatic reset x 7
	[8] Automatic reset x 8	[8] Automatic reset x 8
	[9] Automatic reset x 9	[9] Automatic reset x 9
	[10] Automatic reset x 10	[10] Automatic reset x 10

Table 5.133 Conversion of Parameter 405

	VLT 5000 series	FC 302 series
Parameter	406 Automatic restart time	14-21 Automatic Restart Time
Range	0 – 10 s	0 – 600 s

Table 5.134 Conversion of Parameter 406

	5000 series	FC 302 series
Parameter	407 Mains failure	14-10 Mains Failure
Data range	[0] No function	[0] No function
	[1] Controlled ramp down	[1] Controlled ramp down
	[2] Controlled ramp down and trip	[2] Controlled ramp down and trip
	[3] Coast	[3] Coast
	[4] Kinetic back-up	[4] Kinetic back-up
	[5] Controlled alarm suppression	[5] Kinetic back-up, trip suppression

Table 5.135 Conversion of Parameter 407

	VLT 5000 series	FC 302 series
Parameter	408 Quick discharge	Not converted

Table 5.136 Conversion of Parameter 408

	VLT 5000 series	FC 302 series
Parameter	409 Trip delay torque	14-25 Trip Delay at Torque Limit
Range	0 – 60 s (60=OFF)	0 – 60 s (60=OFF)

Table 5.137 Conversion of Parameter 409

	VLT 5000 series	FC 302 series
Parameter	410 Trip delay inverter	14-26 Trip Delay at Inverter Fault
Range	0 – 35 s	0 – 35 s

Table 5.138 Conversion of Parameter 410

	VLT 5000 series	FC 302 series
Parameter	411 Switching frequency	14-01 Switching Frequency
Range	Unsigned 16 (6)	Unsigned 8 (5)
	1.5 – 14 kHz	< 2.3 ⇒ 2.0 kHz [2] 2.3 > 2.7 ⇒ 2.5 kHz [3] 2.8 > 3.2 ⇒ 3.0 kHz [4] 3.3 > 3.7 ⇒ 3.5 kHz [5] 3.8 > 4.5 ⇒ 4.0 kHz [6] 4.6 > 5.5 ⇒ 5.0 kHz [7] 5.6 > 6.5 ⇒ 6.0 kHz [8] 6.6 > 7.5 ⇒ 7.0 kHz [9] 7.6 > 9.0 ⇒ 8.0 kHz [10] 9.1 > ⇒ 10.0 kHz [11]

Table 5.139 Conversion of Parameter 411

	VLT 5000 series	FC 302 series
Parameter	412 Output frequency dependent switching frequency	Not converted

Table 5.140 Conversion of Parameter 412

	VLT 5000 series	FC 302 series
Parameter	413 Overmodulation function	14-03 Overmodulation function
Options	[0] Off	[0] Off
	[1] On	[1] On

Table 5.141 Conversion of Parameter 413

	VLT 5000 series	FC 302 series
Parameter	414 Minimum feedback	Not converted

Table 5.142 Conversion of Parameter 414

	VLT 5000 series	FC 302 series
Parameter	415 Maximum feedback	Not converted

Table 5.143 Conversion of Parameter 415

	VLT 5000 series	FC 302 series
Parameter	416 Feedback Unit	3-01 Reference/feedback Unit
Options	[0] None	[0] None
	[1] %	[1] %
	[2] PPM	[5] PPM
	[3] rpm	[2] RPM
	[4] bar	[71] bar
	[5] Cycle/min	Not supported
	[6] Pulse/s	[12] Pulse/s
	[7] Unit s/s	Not supported
	[8] Unit s/min	Not supported
	[9] Unit s/h	Not supported
	[10] °C	[60] °C
	[11] Pa	[72] Pa
	[12] l/s	[20] l/s
	[13] m3/s	[23] m3/s
	[14] l/min	[21] l/min
	[15] m3/min	[24] m3/min
	[16] l/h	[22] l/h
	[17] m3/h	[25] m3/h
	[18] kg/s	[30] kg/s
	[19] kg/min	[31] kg/min
	[20] kg/h	[32] kg/h
	[21] t/min	[33] t/min
	[22] t/h	[34] t/h
	[23] m	[45] m
	[24] Nm	[4] Nm
	[25] m/s	[40] m/s

Table 5.144 Conversion of Parameter 416 part 1



	VLT 5000 series	FC 302 series
Parameter	416 Feedback Unit	3-01 Reference/feedback Unit
	[26] m/min	[41] m/min
	[27] °F	[160] °F
	[28] in wg	[172] in wg
	[29] gal/s	[121] gal/s
	[30] ft3/s	[125] ft3/s
	[31] gal/min	[122] gal/min
	[32] ft3/min	[126] ft3/min
	[33] gal/h	[123] gal/h
	[34] ft3/h	[127] ft3/h
	[35] lb/s	[130] lb/s
	[36] lb/min	[131] lb/min
	[37] lb/h	[132] lb/h
	[38] lb ft	[150] lb ft
	[39] ft/s	[140] ft/s
	[40] ft/min	[141] ft/min

Table 5.145 Conversion of Parameter 416 part2

	VLT 5000 series	FC 302 series
Parameter	417 Speed PID proportional gain	7-02 Speed PID proportional gain
Data range	0.000 – 0.150	0.000 – 1.000

Table 5.146 Conversion of Parameter 417

	VLT 5000 series	FC 302 series
Parameter	418 Speed PID Integral Time	7-03 Speed PID proportional gain
Data range	2.0 – 999.9	2.0 – 20000.0

Table 5.147 Conversion of Parameter 418

	VLT 5000 series	FC 302 series
Parameter	419 Speed PID Differentiation Time	7-04 Speed PID Differentiation Time
Data range	0.0 – 200.0	0.0 – 200.0

Table 5.148 Conversion of Parameter 419

	VLT 5000 series	FC 302 series
Parameter	420 Speed PID D-gain limit	7-05 Speed PID Diff. Gain Limit
Data range	5.0 – 50.0	1.0 – 20.0

Table 5.149 Conversion of Parameter 420

	VLT 5000 series	FC 302 series
Parameter	421 Speed PID low-pass filter	7-06 Speed PID Lowpass Filter Time
Data range	5.0 – 200.0 ms	1.0 – 100.0

Table 5.150 Conversion of Parameter 421

	VLT 5000 series	FC 302 series
Parameter	422 U0 voltage at 0 Hz	1-55 U0 voltage
Data range	0.0 – par. 103	0.0 – 1000.0 V

Table 5.151 Conversion of Parameter 422

	VLT 5000 series	FC 302 series
Parameter	423 U1 voltage	1-55 U1 voltage
Data range	0.0 – par. 103	0.0 – 1000.0 V

Table 5.152 Conversion of Parameter 423

	VLT 5000 series	FC 302 series
Parameter	424 F1 frequency	1-56 F1 frequency
Data range	0.0 – par. 104	0.0 – 1000.0 Hz

Table 5.153 Conversion of Parameter 424

	VLT 5000 series	FC 302 series
Parameter	425 U2 voltage	1-55 U2 voltage
Data range	0.0 – par. 103	0.0 – 1000.0 V

Table 5.154 Conversion of Parameter 425

	VLT 5000 series	FC 302 series
Parameter	426 F2 frequency	1-56 F2 frequency
Data range	0.0 – par. 104	0.0 – 1000.0 Hz

Table 5.155 Conversion of Parameter 426

	VLT 5000 series	FC 302 series
Parameter	427 U3 voltage	1-55 U3 voltage
Data range	0.0 – par. 103	0.0 – 1000.0 V

Table 5.156 Conversion of Parameter 427

	VLT 5000 series	FC 302 series
Parameter	428 F3 frequency	1-56 F3 frequency
Data range	0.0 – par. 104	0.0 – 1000.0 Hz

Table 5.157 Conversion of Parameter 428

	VLT 5000 series	FC 302 series
Parameter	429 U4 voltage	1-55 U4 voltage
Data range	0.0 – par. 103	0.0 – 1000.0 V

Table 5.158 Conversion of Parameter 429

	VLT 5000 series	FC 302 series
Parameter	430 F4 frequency	1-56 F4 frequency
Data range	0.0 – par. 104	0.0 – 1000.0 Hz

Table 5.159 Conversion of Parameter 430

	VLT 5000 series	FC 302 series
Parameter	431 U5 voltage	1-55 U5 voltage
Data range	0.0 – par. 103	0.0 – 1000.0 V

Table 5.160 Conversion of Parameter 431

	VLT 5000 series	FC 302 series
Parameter	432 F5 frequency	1-56 F5 frequency
Data range	0.0 – par. 104	0.0 – 1000.0 Hz

Table 5.161 Conversion of Parameter 432

	VLT 5000 series	FC 302 series
Parameter	433 Torque control, open loop proportional gain	7-12 Torque PI Integration Time
Data range	0 (Off) – 500%	0 (Off) – 500%

Table 5.162 Conversion of Parameter 433

	VLT 5000 series	FC 302 series
Parameter	434 Torque control, open loop integral time	7-13 Torque PI Integration Time
Data range	0.002 – 2.000 sec	0.002 – 2.000 sec

Table 5.163 Conversion of Parameter 434

	VLT 5000 series	FC 302 series
Parameter	437 Process PID Normal/Inverse contr	7-30 Process PID Normal/ Inverse Control
Options	[0] Normal	[0] Normal
	[1] Inverse	[1] Inverse

Table 5.164 Conversion of Parameter 437

	VLT 5000 series	FC 302 series
Parameter	438 Process PID Anti windup	7-31 Process PID Anti Windup
Options	[0] Off	[0] Off
	[1] On	[1] On

Table 5.165 Conversion of Parameter 438

	VLT 5000 series	FC 302 series
Parameter	439 Process PID start frequency	7-32 Process PID Start Speed
Data range	Fmin – fmax	0 – 6000 rpm

Table 5.166 Conversion of Parameter 439

	VLT 5000 series	FC 302 series
Parameter	440 Process PID proportional gain	7-33 Process PID proportional gain
Data range	0.00 – 10.00	0.00 – 10.00

Table 5.167 Conversion of Parameter 440

	VLT 5000 series	FC 302 series
Parameter	441 Process PID integral time	7-34 Process PID integral time
Data range	0.01 – 9999.99	0.01 – 10000.00

Table 5.168 Conversion of Parameter 441

	VLT 5000 series	FC 302 series
Parameter	442 Process PID differentiation time	7-35 Process PID Differentiation Time
Data range	0.00 – 10.00	0.00 – 10.00

Table 5.169 Conversion of Parameter 442

	VLT 5000 series	FC 302 series
Parameter	443 Process PID diff. gain limit	7-36 Process PID Diff. Gain Limit
Data range	5.0 – 50.0	0.00 – 10.00

Table 5.170 Conversion of Parameter 443

	VLT 5000 series	FC 302 series
Parameter	444 Process PID lowpass filter time	Not supported

Table 5.171 Conversion of Parameter 444

	VLT 5000 series	FC 302 series
Parameter	445 Flying start	1-73 Flying Start
Options	[0] Off	[0] Disable
	[1] On	[1] Enable

**Table 5.172 Conversion of Parameter 445**

	VLT 5000 series	FC 302 series
Parameter	446 Switching pattern	14-00 Switching Pattern
Options	[0] 60 AVM	[0] 60 AVM
	[1] SFAVM	[1] SFAVM

**Table 5.173 Conversion of Parameter 446**

	VLT 5000 series	FC 302 series
Parameter	447 Torque compensation	Not supported

**Table 5.174 Conversion of Parameter 447**

	VLT 5000 series	FC 302 series
Parameter	448 Gear ratio	Not supported

**Table 5.175 Conversion of Parameter 448**

	VLT 5000 series	FC 302 series
Parameter	449 Friction loss	Not supported

**Table 5.176 Conversion of Parameter 449**

	VLT 5000 series	FC 302 series
Parameter	450 Mains voltage at mains fault	14-11 Mains Voltage at Mains Fault
Range	180 – 690 V	100 – 800 V

**Table 5.177 Conversion of Parameter 450**

	VLT 5000 series	FC 302 series
Parameter	453 Gear ratio, speed close loop	7-07 Speed PID Feedback Gear Ratio
Range	0.01 – 100.00	0.0001 – 32.0000

**Table 5.178 Conversion of Parameter 453**

	VLT 5000 series	FC 302 series
Parameter	454 Dead time compensation	Not supported

**Table 5.179 Conversion of Parameter 454**

	VLT 5000 series	FC 302 series
Parameter	455 Frequency range monitor	Not supported

**Table 5.180 Conversion of Parameter 455**

	VLT 5000 series	FC 302 series
Parameter	457 Phase loss functions	14-12 Function at Mains Imbalance
Options	[0] Trip	[0] Trip
	[1] Warning	[1] Warning

**Table 5.181 Conversion of Parameter 457**

	VLT 5000 series	FC 302 series
Parameter	483 Dynamic DC link compensation	Not supported

**Table 5.182 Conversion of Parameter 483**

## 5.6 VLT® 5000 Parameter Group 5

	VLT 5000 series	FC 302 series
Parameter	500 Address	8-31 Address
Range	0 - 126	0 - 126

Table 5.183 Conversion of Parameter 500

	VLT 5000 series	FC 302 series
Parameter	501 Baud rate	8-32 FC Port Baud Rate
Options	[0] 300	Not supported
	[1] 600	Not supported
	[2] 1200	Not supported
	[3] 2400	[0] 2400
	[4] 4800	[1] 4800
	[5] 9600	[2] 9600

Table 5.184 Conversion of Parameter 501

	VLT 5000 series	FC 302 series
Parameter	502 Coasting	8-50 Coasting Select
Parameter	503 Quick - Stop	8-51 Quick Stop Select
Parameter	504 DC brake	8-52 DC Brake Select
Parameter	505 Start	8-53 Start Select
Parameter	506 Reversing	8-54 Reversing Select
Parameter	507 Setup select	8-55 Set-up Select
Parameter	508 Preset reference select	8-56 Preset Reference Select
Parameter type	Unsigned 8 (5)	Unsigned 8 (5)
Options	[0] Digital input	[0] Digital input
	[1] Bus	[1] Bus
	[2] Logic AND	[2] Logic AND
	[3] Logic OR	[3] Logic OR

Table 5.185 Conversion of Parameter 502 - 508

	VLT 5000 series	FC 302 series
Parameter	509 Bus Jog 1	8-90 Bus Jog 1 Speed
Range	0.0 – par. 202	0.0 – par. 4-13

Table 5.186 Conversion of Parameter 509

	VLT 5000 series	FC 302 series
Parameter	510 Bus Jog 2	8-91 Bus Jog 2 Speed
Range	0.0 – par. 202	0.0 – par. 4-13

Table 5.187 Conversion of Parameter 510

	VLT 5000 series	FC 302 series
Parameter	512 Telegram Profile	8-10 Control Word Profile
Range	[0] Fieldbus profile	[1] ProfiDrive profile
	[1] FC profile	[0] FC profile

Table 5.188 Conversion of Parameter 512

	VLT 5000 series	FC 302 series
Parameter	513 Bus time interval	Not Converted

Table 5.189 Conversion of Parameter 513

	VLT 5000 series	FC 302 series
Parameter	514 Bus time interval function	Not Converted

Table 5.190 Conversion of Parameter 514

	VLT 5000 series	FC 302 series
Parameter	515 Reference %	16-02 Reference %

Table 5.191 Conversion of Parameter 515

	VLT 5000 series	FC 302 series
Parameter	516 Reference Unit	16-01 Reference [Unit]

Table 5.192 Conversion of Parameter 516

	VLT 5000 series	FC 302 series
Parameter	517 Feedback	16-52 Feedback[Unit]

Table 5.193 Conversion of Parameter 517

	VLT 5000 series	FC 302 series
Parameter	518 Frequency	16-13 Frequency

Table 5.194 Conversion of Parameter 518

	VLT 5000 series	FC 302 series
Parameter	519 Frequency x scaling	Not converted

Table 5.195 Conversion of Parameter 519

	VLT 5000 series	FC 302 series
Parameter	520 Current	16-14 Motor current

Table 5.196 Conversion of Parameter 520

	VLT 5000 series	FC 302 series
Parameter	521 Torque	16-22 Torque [%]
		16-21 Torque [%] high resolution

Table 5.197 Conversion of Parameter 521

	VLT 5000 series	FC 302 series
Parameter	522 Power, kW	16-10 Power [kW]

Table 5.198 Conversion of Parameter 522

	VLT 5000 series	FC 302 series
Parameter	523 Power, HP	16-11 Power [hp]

Table 5.199 Conversion of Parameter 523

	VLT 5000 series	FC 302 series
Parameter	524 Motor voltage	16-12 Motor Voltage

Table 5.200 Conversion of Parameter 524

	VLT 5000 series	FC 302 series
Parameter	525 DC link voltage	16-30 DC Link Voltage

Table 5.201 Conversion of Parameter 525

	VLT 5000 series	FC 302 series
Parameter	526 Motor temp.	16-18 Motor Thermal

Table 5.202 Conversion of Parameter 526

	VLT 5000 series	FC 302 series
Parameter	527 VLT® temp.	16-35 Inverter Thermal

Table 5.203 Conversion of Parameter 527

	VLT 5000 series	FC 302 series
Parameter	528 Digital input	16-60 Digital Input
Options	Term. 16 (binary 0000 0001)	Term. X30/2 (binary)
	Term. 17 (binary 0000 0010)	Term. X30/3 (binary)
	Term. 18 (binary 0000 0100)	Term. 18 (binary)
	Term. 19 (binary 0000 1000)	Term. 19 (binary)
	Term. 27 (binary 0001 0000)	Term. 27 (binary)
	Term. 32 (binary 0010 0000)	Term. 32 (binary)
	Term. 33 (binary 0100 0000)	Term. 33 (binary)

Table 5.204 Conversion of Parameter 528

	VLT 5000 series	FC 302 series
Parameter	529 Analogue input 53	16-62 Analog Input 53

Table 5.205 Conversion of Parameter 529

\* = Switch "S201" must be OFF

	VLT 5000 series	FC 302 series
Parameter	530 Analogue input 54	16-64 Analog Input 54

Table 5.206 Conversion of Parameter 530

\*\* = Switch "S202" must be OFF

	VLT 5000 series	FC 302 series
Parameter	531 Analogue input 60	16-64 Analog Input 54

Table 5.207 Conversion of Parameter 531

\*\*\* = Switch "S202" must be ON

	VLT 5000 series	FC 302 series
Parameter	532 Pulse reference	16-51 Pulse Reference

Table 5.208 Conversion of Parameter 532

	VLT 5000 series	FC 302 series
Parameter	533 External reference %	16-50 External Reference

Table 5.209 Conversion of Parameter 533

	VLT 5000 series	FC 302 series
Parameter	534 Status word, binary	16-03 Status Word

Table 5.210 Conversion of Parameter 534

	VLT 5000 series	FC 302 series
Parameter	535 Brake power/2 min	16-33 Brake Energy /2 min

Table 5.211 Conversion of Parameter 535

	VLT 5000 series	FC 302 series
Parameter	536 Brake power/s	16-32 Brake Energy /s

Table 5.212 Conversion of Parameter 536

	VLT 5000 series	FC 302 series
Parameter	537 Heat sink temp	16-34 Heatsink Temp.

Table 5.213 Conversion of Parameter 537

	VLT 5000 series	FC 302 series
Parameter	538 Alarm word	14-72 Legacy Alarm Word

Table 5.214 Conversion of Parameter 538

	VLT 5000 series	FC 302 series
Parameter	539 VLT® Control word	16-00 Control Word

Table 5.215 Conversion of Parameter 539

	VLT 5000 series	FC 302 series
Parameter	540 Warning word	14-73 Legacy Warning Word

Table 5.216 Conversion of Parameter 540

	VLT 5000 series	FC 302 series
Parameter	541 Extended status word	14-74 Leg. Ext. Status Word

Table 5.217 Conversion of Parameter 541

	VLT 5000 series	FC 302 series
Parameter	553 Display text 1	Not converted

Table 5.218 Conversion of Parameter 553

	VLT 5000 series	FC 302 series
Parameter	554 Display text 2	Not converted

Table 5.219 Conversion of Parameter 554

	VLT 5000 series	FC 302 series
Parameter	557 Motor RPM	16-17 Speed [RPM]

Table 5.220 Conversion of Parameter 557

	VLT 5000 series	FC 302 series
Parameter	558 Motor RPM x scaling	Not converted

Table 5.221 Conversion of Parameter 558

	VLT 5000 series	FC 302 series
Parameter number	580, 581, 582 Define parameter	Not converted

Table 5.222 Conversion of Parameter 580-582

## 5.7 VLT® 5000 Parameter Group 6

	VLT 5000 series	FC 302 series
Parameter	600 Operating hours	15-00 Operating hours

Table 5.223 Conversion of Parameter 600

	VLT 5000 series	FC 302 series
Parameter	601 Hours run	15-01 Running Hours

Table 5.224 Conversion of Parameter 601

	VLT 5000 series	FC 302 series
Parameter	602 kWh counter	15-02 kWh Counter

Table 5.225 Conversion of Parameter 602

	VLT 5000 series	FC 302 series
Parameter	603 Numbers of power up	15-03 Power Up's

Table 5.226 Conversion of Parameter 603

	VLT 5000 series	FC 302 series
Parameter	604 Numbers of over temp.	15-04 Over Temp's

Table 5.227 Conversion of Parameter 604

	VLT 5000 series	FC 302 series
Parameter	605 Numbers of over voltage	15-05 Over Volt's

Table 5.228 Conversion of Parameter 605

	VLT 5000 series	FC 302 series
Parameter	606 Data log: Digital input	Not converted

Table 5.229 Conversion of Parameter 606

	VLT 5000 series	FC 302 series
Parameter	607 Data log: Bus commands	Not converted

Table 5.230 Conversion of Parameter 607

	VLT 5000 series	FC 302 series
Parameter	608 Data log: Status word	Not converted

Table 5.231 Conversion of Parameter 608

	VLT 5000 series	FC 302 series
Parameter	609 Data log: Reference	Not converted

Table 5.232 Conversion of Parameter 609

	VLT 5000 series	FC 302 series
Parameter	610 Data log: Feedback	Not converted

Table 5.233 Conversion of Parameter 610

	VLT 5000 series	FC 302 series
Parameter	611 Data log: Motor frequency	Not converted

Table 5.234 Conversion of Parameter 611

	VLT 5000 series	FC 302 series
Parameter	612 Data log: Motor voltage	Not converted

Table 5.235 Conversion of Parameter 612

	VLT 5000 series	FC 302 series
Parameter	613 Data log: Motor current	Not converted

Table 5.236 Conversion of Parameter 613

	VLT 5000 series	FC 302 series
Parameter	614 Data log: DC link voltage	Not converted

Table 5.237 Conversion of Parameter 614

	VLT 5000 series	FC 302 series
Parameter	615 Fault log: Error code	15-30 Fault Log: Error Code

Table 5.238 Conversion of Parameter 615

	VLT 5000 series	FC 302 series
Parameter	616 Fault log: Time	15-32 Fault Log: Time

Table 5.239 Conversion of Parameter 616

	VLT 5000 series	FC 302 series
Parameter	617 Fault log: Value	15-31 Fault Log: Value

Table 5.240 Conversion of Parameter 617

	VLT 5000 series	FC 302 series
Parameter	618 Reset of kWh counter	15-06 Reset kWh Counter
Options	[0] No reset	[0] Do not reset
	[1] Reset	[1] Reset counter

Table 5.241 Conversion of Parameter 618

	VLT 5000 series	FC 302 series
Parameter	619 Reset of Hours run	15-07 Reset Running Hours Counter
Options	[0] No reset	[0] Do not reset
	[1] Reset	[1] Reset counter

Table 5.242 Conversion of Parameter 619

	VLT 5000 series	FC 302 series
Parameter	620 Operation mode	14-22 Operation Mode
Options	[0] Normal operation	[0] Normal operation
	[1] Function with deactivated inverter	Not supported
	[2] Control card test	[2] Control card test
	[3] Initialisation	[3] Initialisation

**Table 5.243 Conversion of Parameter 620**

	VLT 5000 series	FC 302 series
Parameter	621 Name plate: VLT® type	Not converted

**Table 5.244 Conversion of Parameter 621**

	VLT 5000 series	FC 302 series
Parameter	622 Name plate: Power section	Not converted

**Table 5.245 Conversion of Parameter 622**

	VLT 5000 series	FC 302 series
Parameter	623 Name plate: VLT® ordering no.	Not converted

**Table 5.246 Conversion of Parameter 623**

	VLT 5000 series	FC 302 series
Parameter	624 Name plate: Software version no.	Not converted

**Table 5.247 Conversion of Parameter 624**

	VLT 5000 series	FC 302 series
Parameter	625 Name plate: LCP ID no.	Not converted

**Table 5.248 Conversion of Parameter 625**

	VLT 5000 series	FC 302 series
Parameter	626 Name plate: Data base ID	Not converted

**Table 5.249 Conversion of Parameter 626**

	VLT 5000 series	FC 302 series
Parameter	627 Name plate: Power ID no.	Not converted

**Table 5.250 Conversion of Parameter 627**

	VLT 5000 series	FC 302 series
Parameter	628 Name plate: Application type	Not converted

**Table 5.251 Conversion of Parameter 628**

	VLT 5000 series	FC 302 series
Parameter	629 Name plate: Application type no.	Not converted

**Table 5.252 Conversion of Parameter 629**

	VLT 5000 series	FC 302 series
Parameter	630 Name plate: Com. type	Not converted

**Table 5.253 Conversion of Parameter 630**

	VLT 5000 series	FC 302 series
Parameter	631 Name plate: Com. Type no.	Not converted

**Table 5.254 Conversion of Parameter 631**

## 5.8 VLT® 5000 Parameter Group 7

	VLT 5000 series	FC 302 series
Parameter	700 System control	8-02 Control Word Source 33-82 Drive Status Monitoring
Options	[0] Enable SyncPos	Par. 8-02: [5] Option C0 Par. 33-82: [1] On
	[1] Disable SyncPos	Par. 8-02: [1] FC RS-485
	[2] Enable SyncPos without VLT monitoring	Par. 8-02: [5] Option C0 Par. 33-82: [0] Off

Table 5.255 Conversion of Parameter 700

	VLT 5000 series	FC 302 series
Parameter	701 Program number	33-80 Activated Program Number
Options	-1 – 127	-1 – 127

Table 5.256 Conversion of Parameter 701

	VLT 5000 series	FC 302 series
Parameter	702 PID Proportional factor	32-60 Proportional factor
Options	0 – 65000	0 – 100000

Table 5.257 Conversion of Parameter 702

	VLT 5000 series	FC 302 series
Parameter	703 PID Derivative factor	32-61 Derivative factor
Options	0 – 65000	0 – 100000

Table 5.258 Conversion of Parameter 703

	VLT 5000 series	FC 302 series
Parameter	704 PID Integral factor	32-62 Integral factor
Options	0 – 65000	0 – 100000

Table 5.259 Conversion of Parameter 704

	VLT 5000 series	FC 302 series
Parameter	705 PID Integral bandwidth	32-63 Limit Value for Integral Sum
Options	0 – 1000	0 – 1000

Table 5.260 Conversion of Parameter 705

	VLT 5000 series	FC 302 series
Parameter	706 PID Active bandwidth	32-64 PID Bandwidth
Options	0 – 65000	0 – 1000

Table 5.261 Conversion of Parameter 706

	VLT 5000 series	FC 302 series
Parameter	707 PID Velocity Feed-forward	32-65 Velocity Feed-Forward
Options	0 – 65000	0 – 100000

Table 5.262 Conversion of Parameter 707

	VLT 5000 series	FC 302 series
Parameter	708 PID Acceleration Feed-forward	32-66 Acceleration Feed-Forward
Options	0 – 65000	0 – 100000

Table 5.263 Conversion of Parameter 708

	VLT 5000 series	FC 302 series
Parameter	709 PID Velocity filter	33-26 Velocity Filter
Options	-500000 – 500000	-1073741824 – 107374203

Table 5.264 Conversion of Parameter 709

	VLT 5000 series	FC 302 series
Parameter	710 – 779	19-10 -19-79
Options	User defined	User defined

Table 5.265 Conversion of Parameters 710 to 779

	VLT 5000 series	FC 302 series
Parameter	780 Dead time compensation	Not supported
Options	[0] Off	
	[1] On	

Table 5.266 Conversion of Parameter 780

	VLT 5000 series	FC 302 series
Parameter	781 Program ID	Not supported
Options	0 – 65000	

Table 5.267 Conversion of Parameter 781

	VLT 5000 series	FC 302 series
Parameter	795 – 799 User defined (read only)	19-95 -19-99 User defined (read only)
Options	User defined	User defined

Table 5.268 Conversion of Parameters 795 to 799



## 5.9 VLT® 5000 Parameter Group 8

	VLT 5000 series	FC 302 series
Parameter	800 PROFIBUS DP	Not converted

Table 5.269 Conversion of Parameter 800

	VLT 5000 series	FC 302 series
Parameter	801 Baud rate selection	Not converted

Table 5.270 Conversion of Parameter 801

	VLT 5000 series	FC 302 series
Parameter	802 Minimum station delay	Not converted

Table 5.271 Conversion of Parameter 802

	VLT 5000 series	FC 302 series
Parameter	803 Time out after bus error	8-03 Control Word Timeout Time
Range	1 – 99	0.1 – 18000.0

Table 5.272 Conversion of Parameter 803

	VLT 5000 series	FC 302 series
Parameter	804 Response after bus time out	8-04 Control Word Timeout Function 8-02 Control Word Source
Range	[0] Off	[0] Off
	[1] Freeze output frequency	[1] Freeze output frequency
	[2] Stop	[2] Stop
	[3] Jogging	[3] Jogging
	[4] Max speed	[4] Max speed
	[5] Stop and trip	[5] Stop and trip
	[6] No com. option control	Par. 802 to RS485
	[7] Select set up 4	[10] Select set up 4

Table 5.273 Conversion of Parameter 804

	VLT 5000 series	FC 302 series
Parameter	805 Function of control word bit 10	8-14 Configurable Control Word CTW
Range	[0] No function	[0] None
	[1] Bit 10 = 1 => CTW active	[1] Profile default
	[2] Bit 10 = 0 => CTW active	[2] CTW Valid, active low
	[3] Bit 10 = 1 => Time out	[1] Profile default

Table 5.274 Conversion of Parameter 805

	VLT 5000 series	FC 302 series
Parameter	806 SAP selection (FMS)	Not converted

Table 5.275 Conversion of Parameter 806

	VLT 5000 series	FC 302 series
Parameter	808 ProfiDrives status word	Not converted

Table 5.276 Conversion of Parameter 808

	VLT 5000 series	FC 302 series
Parameter	849 Extended diagnose	8-07 Diagnosis Trigger
Options	[0] Disable	[0] Disable
	[1] Alarm	[1] Trigger on alarm
	[2] Alarm and warnings	[2] Trigger on alarm/warn.

Table 5.277 Conversion of Parameter 849

## 5.10 VLT® 5000 Parameter Group 9

	VLT 5000 series	FC 302 series
Parameter	900 Write PPO type 1	Not converted

Table 5.278 Conversion of Parameter 900

	VLT 5000 series	FC 302 series
Parameter	901 Write PPO type 2	Not converted

Table 5.279 Conversion of Parameter 901

	VLT 5000 series	FC 302 series
Parameter	902 Write PPO type 3	Not converted

Table 5.280 Conversion of Parameter 902

	VLT 5000 series	FC 302 series
Parameter	903 Write PPO type 4	Not converted

Table 5.281 Conversion of Parameter 903

	VLT 5000 series	FC 302 series
Parameter	904 PPO type select for DP	Not converted

Table 5.282 Conversion of Parameter 904

	VLT 5000 series	FC 302 series
Parameter	907 Read PPO type 1	Not converted

Table 5.283 Conversion of Parameter 907

	VLT 5000 series	FC 302 series
Parameter	908 Read PPO type 2	Not converted

Table 5.284 Conversion of Parameter 908

	VLT 5000 series	FC 302 series
Parameter	909 Read PPO type 3	Not converted

Table 5.285 Conversion of Parameter 909

	VLT 5000 series	FC 302 series
Parameter	910 Read PPO type 4	Not converted

Table 5.286 Conversion of Parameter 910

	VLT 5000 series	FC 302 series
Parameter	911 PPO type for FMS read	Not converted

Table 5.287 Conversion of Parameter 911

	VLT 5000 series	FC 302 series
Parameter	913 Broadcast index	Not converted

Table 5.288 Conversion of Parameter 913

	VLT 5000 series	FC 302 series
Parameter	914 Broadcast off-set	Not converted

Table 5.289 Conversion of Parameter 914

	VLT 5000 series	FC 302 series
Parameter	915 PCD config write	9-15 PCD Write Configuration
Options	[0] None	[0] None
	[204] Minimum Reference	[302] Minimum Reference
	[205] Maximum Reference	[203] Maximum Reference
	[219] Catch up/slow Down Value	[312] Catch up/slow Down Value
	[207] Ramp 1 Ramp up Time	[341] Ramp 1 Ramp up Time
	[208] Ramp 1 Ramp Down Time	[342] Ramp 1 Ramp Down Time
	[209] Ramp 2 Ramp up Time	[351] Ramp 2 Ramp up Time
	[210] Ramp 2 Ramp down Time	[352] Ramp 2 Ramp down Time
	[211] Jog Ramp Time	[380] Jog Ramp Time
	[212] Quick Stop Ramp Time	[381] Quick Stop Ramp Time
	[201] Motor Low Limit [Hz]	[412] Motor Speed Low Limit [Hz]
	[202] Motor High Limit [Hz]	[414] Motor Speed High Limit [Hz]
	[221] Torque Limit Motor Mode	[416] Torque Limit Motor Mode
	[222] Torque Limit Generator Mode	[417] Torque Limit Generator Mode
	[509] Bus Jog 1 Speed	[890] Bus Jog 1 Speed
	[510] Bus Jog 2 Speed	[891] Bus Jog 2 Speed
Comments	VLT® 5000 supports more write signals. If a not-supported signal is written then the corresponding signal is set to [0] None.	

Table 5.290 Conversion of Parameter 915

	VLT 5000 series	FC 302 series
Parameter	916 PCD config read	9-16 PCD Read Configuration
Options	[0] None	[0] None
	[538] Alarm word	[1472] VLT Alarm Word
	[540] Warning word	[1473] VLT Warning Word
	[541] Ext. status word	[1474] VLT Ext. status Word
	[600] Operating hours	[1500] Operating hours
	[601] Running hours	[1501] Running hours
	[602] kWh Counter	[1502] kWh Counter
	[539] Control word	[1600] Control word
	[516] Reference [Unit]	[1601] Reference [Unit]
	[515] Reference %	[1602] Reference %
	[534] Status word	[1603] Status word
	[522] Power [kW]	[1610] Power [kW]
	[523] Power [HP]	[1611] Power [HP]
	[524] Motor voltage	[1612] Motor voltage
	[518] Motor frequency	[1613] Motor frequency
	[520] Motor current	[1614] Motor current
	[557] Motor RPM	[1617] Motor speed
	[526] Motor thermal	[1618] Motor thermal
	[521] Torque	[1622] Torque %
	[525] DC link voltage	[1630] DC link voltage
	[536] Brake energy/s	[1632] Brake energy/s
	[535] Brake energy/2 min	[1633] Brake energy/2 min
	[537] Heat sink temp.	[1634] Heat sink temp.
	[527] Inverter Thermal	[1635] Inverter Thermal
	[533] External reference	[1650] External reference
	[532] Pulse reference	[1651] Pulse reference
	[517] Feedback [Unit]	[1652] Feedback [Unit]
	[528] Digital input	[1660] Digital input
[529] Analog input 53	[1662] Analog input 53	
[530] Analog input 54	[1664] Analog input 54	
[531] Analog input 60	[1664] Analog input 54	

Table 5.291 Conversion of Parameter 916

	VLT 5000 series	FC 302 series
Parameter	917 Spontaneous messages	Not converted

Table 5.292 Conversion of Parameter 917

	VLT 5000 series	FC 302 series
Parameter	918 Station address	9-18 Node Address
Range	0 - 125	0 - 125

Table 5.293 Conversion of Parameter 918

	VLT 5000 series	FC 302 series
Parameter	927 Parameter edit	9-27 Parameter Edit
Options	[0] Disable	[0] Disable
	[1] Enable	[1] Enable

Table 5.294 Conversion of Parameter 927

	VLT 5000 series	FC 302 series
Parameter	928 Control authority	9-28 Process Control
Options	[0] Disable	[0] Disable
	[1] Enable	[1] Enable cyclic master

Table 5.295 Conversion of Parameter 928

	VLT 5000 series	FC 302 series
Parameter	953 Warning parameter	9-53 Profibus Warning Word

Table 5.296 Conversion of Parameter 953

	VLT 5000 series	FC 302 series
Parameter	964 Identification	9-64 Device Identification

Table 5.297 Conversion of Parameter 964

	VLT 5000 series	FC 302 series
Parameter	965 Profile Number	9-65 Profile Number

Table 5.298 Conversion of Parameter 965

	VLT 5000 series	FC 302 series
Parameter	967 Control word (FMS)	Not converted

Table 5.299 Conversion of Parameter 967

	VLT 5000 series	FC 302 series
Parameter	968 Status word (FMS)	Not converted

Table 5.300 Conversion of Parameter 968

	VLT 5000 series	FC 302 series
Parameter	970 Parameter set-up selection	9-70 Edit Set-up
Options	[0] Factory setting	[0] Factory setting
	[1] Parameter setup 1	[1] Parameter setup 1
	[2] Parameter setup 2	[2] Parameter setup 2
	[3] Parameter setup 3	[3] Parameter setup 3
	[4] Parameter setup 4	[4] Parameter setup 4
	[5] Active setup	[9] Active setup

Table 5.301 Conversion of Parameter 970

	VLT 5000 series	FC 302 series
Parameter	971 Save data values	9-71 Profibus Save Data Values
Options	Unsigned 8 (5)	Unsigned 8 (5)
	[0] Not active	[0] Off
	[1] Save active setup	[1] Store all setups
	[2] Save edit setup	[1] Store all setups
	[3] Save all setups	[1] Store all setups

**Table 5.302 Conversion of Parameter 971**

	VLT 5000 series	FC 302 series
Parameter	980, 981, 982, 990 Modified parameters	Not converted

**Table 5.303 Conversion of Parameter 980-990**

## 6 Troubleshooting

### 6.1 Step-by-step Troubleshooting

After copying the station address from the VLT® 5000 to the VLT® AutomationDrive FC 302, power must be cycled to the FC 302. The master/PLC should now recognise FC 302 as a VLT® 5000. The NS LED on the MCA 114 option should now be solid green indicating that communication between master and slave is established.

If the NS LED flashes, the master/PLC has not recognized the FC 302:

- Check if station address is the same in the FC 302 as the replaced VLT® 5000.
- Check 9-63 *Actual Baud Rate*. If the frequency converter has a connection to the master, this parameter displays the detected baudrate. If no master has been detected, the parameter displays: "No baud rate found".
- Check 9-53 *Profibus Warning Word*.

Bit	Warn. Word [Hex]	Description
0	0001	Connection with DP-master is not OK
1	0002	Unused
2	0004	FDL (Field-bus Data link Layer) is not OK
3	0008	Clear data command received
4	0010	Actual value is not updated
5	0020	Baudrate search
6	0040	PROFIBUS ASIC is not transmitting
7	0080	Initialising of PROFIBUS is not ok
8	0100	Drive is tripped
9	0200	Internal CAN error
10	0400	Wrong configuration data from PLC
11	0800	Wrong ID sent by PLC
12	1000	Internal error occurred
13	2000	Not configured
14	4000	Timeout active
15	8000	Warning 34 active

Table 6.1 Warning Word

- Check 1.3 *Constraints* for more information on limitations.

## Index

<b>A</b>		<b>T</b>	
Abbreviations.....	5	Terminal.....	4
		Troubleshooting.....	43
<b>B</b>		<b>W</b>	
Brake chopper.....	3	Warning word.....	43
<b>C</b>			
Commissioning.....	10		
Configuration.....	3		
Constrains.....	3		
<b>D</b>			
DIP switches.....	9		
<b>E</b>			
EMC precautions.....	8		
<b>H</b>			
Hardware.....	4		
High voltage.....	6		
<b>I</b>			
Installation.....	7		
<b>L</b>			
LEDs.....	10		
Linked Set-ups.....	5		
Literature.....	3		
<b>M</b>			
MCA 114.....	43		
Mechanical Installation.....	8		
<b>N</b>			
Node address.....	9		
<b>O</b>			
Overview (technical).....	3		
<b>P</b>			
Parameter (mapping list).....	12		
Performance.....	5		
Power size.....	3		





[www.danfoss.com/drives](http://www.danfoss.com/drives)

---

Danfoss can accept no responsibility for possible errors in catalogues, brochures and other printed material. Danfoss reserves the right to alter its products without notice. This also applies to products already on order provided that such alterations can be made without subsequential changes being necessary in specifications already agreed. All trademarks in this material are property of the respective companies. Danfoss and the Danfoss logotype are trademarks of Danfoss A/S. All rights reserved.

---

