

ENGINEERING
TOMORROW

Danfoss

Operating Guide

VACON® NX Inverters FI4-FI8



Contents

1	Introduction	9
1.1	Purpose of this Operating Guide	9
1.2	Additional Resources	9
1.3	Disposal	9
1.4	Type Approvals and Certifications	9
1.5	Start up Quick Guide	10
2	Safety	11
2.1	Safety Symbols	11
2.2	Danger and Warnings	11
2.3	Cautions and Notices	12
3	Product Overview	15
3.1	Introduction	15
3.2	Intended Use	16
3.3	Version History	16
3.4	Standard Features of VACON NX Inverters	16
3.5	Package Label	17
3.6	Description of the Type Code	18
3.7	Enclosure Sizes	19
3.8	Available Protection Ratings	20
3.9	Available EMC Classes	20
3.10	Control Panel	21
3.10.1	Keypad	21
3.10.2	Display	22
3.10.3	Basic Menu Structure	23
4	Receiving the Delivery	24
4.1	Checking the Delivery	24
4.1.1	Accessories for FR4/FI4–FR6/FI6	24
4.1.2	Accessories for FR7/FI7–FR8/FI8	25
4.1.3	Accessories for FR10–FR11 Standalone	25
4.2	Storing the Product	25
4.3	Lifting the Product	26
4.4	Using the Product Modified Label	27
5	Mounting the Unit	28
5.1	Environmental Requirements	28

5.1.1	General Environmental Requirements	28
5.1.2	Ambient Temperature and Derating	28
5.1.3	High Altitude Installation	29
5.2	Cooling Requirements	30
5.2.1	General Cooling Requirements	30
5.2.2	Cooling of FI4 to FI8	30
5.3	Installation Sequence for Wall-mounted AC Drives	31
6	Electrical Installation	32
6.1	Cable Connections	32
6.1.1	General Cable Requirements	32
6.1.2	UL Standards on Cabling	33
6.1.3	Cable Selection and Dimensioning	33
6.1.4	Cable Selection and Dimensioning, North America	33
6.1.5	Fuse Selection	33
6.2	Grounding	33
6.3	EMC-compliant Installation	35
6.4	Get Access and Locate the Terminals	35
6.4.1	Get Access and Locate the Terminals for FR4/FI4	35
6.4.2	Get Access and Locate the Terminals for FR6/FI6	37
6.4.3	Get Access and Locate the Terminals for FR7/FI7	38
6.4.4	Get Access and Locate the Terminals for FR8/FI8	39
6.5	Installing the Cables	41
6.5.1	Additional Instructions for Cable Installation	41
6.5.2	Installing the Cables, FR4–FR6/FI4–FI6	42
6.5.3	Installing the Cables, FR7/FI7	44
6.5.4	Installing the Cables, FR8/FI8	48
7	Control Unit	51
7.1	Control Unit Components	51
7.2	Control Voltage (+24 V/EXT +24 V)	51
7.3	Control Unit Cabling	52
7.3.1	Selection of the Control Cables	52
7.3.2	Control Terminals on OPTA1	52
7.3.2.1	Digital Input Signal Inversions	54
7.3.2.2	Jumper Selections on the OPTA1 Basic Board	55
7.3.3	Control Terminals on OPTA2 and OPTA3	56
7.4	Installation of Option Boards	57
7.5	Galvanic Isolation Barriers	58

8	Using the Control Panel	59
8.1	Navigating on the Control Panel	59
8.2	Using the Monitoring Menu (M1)	59
8.2.1	Monitored Values	59
8.3	Using the Parameter Menu (M2)	60
8.3.1	Finding the Parameter	60
8.3.2	Selecting Values	61
8.3.3	Editing the Values Digit by Digit	62
8.4	Using the Keypad Control Menu	63
8.4.1	Finding the Keypad Control Menu	63
8.4.2	Keypad Control Parameters M3	63
8.4.3	Changing the Control Mode	64
8.4.4	Keypad Reference	64
8.4.4.1	Editing the Frequency Reference	64
8.4.5	Changing the Rotation Direction	65
8.4.6	Disabling the Stop Motor Function	65
8.4.7	Special Functions in Keypad Control Menu	65
8.4.7.1	Selecting the Keypad as the Control Mode	65
8.4.7.2	Copying the Frequency Reference Set to the Control Panel	65
8.5	Using the Active Faults Menu (M4)	66
8.5.1	Finding the Active Faults Menu	66
8.5.2	Examining the Fault Time Data Record	66
8.5.3	Fault Time Data Record	66
8.6	Using the Fault History Menu (M5)	67
8.6.1	Fault History Menu (M5)	67
8.6.2	Resetting the Fault History	67
8.7	Using the System Menu (M6)	68
8.7.1	Finding the System Menu	68
8.7.2	System Menu Functions	68
8.7.3	Changing the Language	71
8.7.4	Changing the Application	71
8.7.5	Copy Parameters (S6.3)	71
8.7.5.1	Saving Parameter Sets (Parameter Sets S6.3.1)	71
8.7.5.2	Uploading Parameters to Control Panel (Up To Keypad, S6.3.2)	72
8.7.5.3	Downloading Parameters to Drive (Down From Keypad, S6.3.3)	72
8.7.5.4	Activating or Deactivating the Automatic Parameter Back-up (P6.3.4)	72
8.7.5.5	Comparing the Parameters	73
8.7.6	Security	73

8.7.6.1	Finding the Security Menu	73
8.7.6.2	Passwords	73
8.7.6.3	Setting a Password	74
8.7.6.4	Entering a Password	74
8.7.6.5	Deactivating the Password Function	74
8.7.6.6	Locking a Parameter	74
8.7.6.7	Start-up Wizard (P6.5.3)	74
8.7.6.8	Activating/Deactivating the Start-up Wizard	75
8.7.6.9	Enabling/Disabling the Change of Multimonitoring Items	75
8.7.7	Keypad Settings	75
8.7.7.1	Finding the Keypad Settings Menu	75
8.7.7.2	Changing the Default Page	76
8.7.7.3	Default Page in the Operating Menu (P6.6.2)	76
8.7.7.4	Setting the Timeout Time	76
8.7.7.5	Contrast Adjustment (P6.6.4)	76
8.7.7.6	Backlight Time (P6.6.5)	76
8.7.8	Hardware Settings	76
8.7.8.1	Finding the Hardware Setting Menu	76
8.7.8.2	Setting the Internal Brake Resistor Connection	77
8.7.8.3	Fan Control	77
8.7.8.4	Changing the Fan Control Settings	77
8.7.8.5	HMI Acknowledge Timeout (P6.7.3)	77
8.7.8.6	Changing the HMI Acknowledge Timeout	78
8.7.8.7	Changing the Number of Retries to Receive HMI Acknowledgement (P6.7.4)	78
8.7.8.8	Sine Filter (P6.7.5)	78
8.7.8.9	Pre-charge Mode (P6.7.6)	78
8.7.9	System Info	78
8.7.9.1	Finding the System Info Menu	78
8.7.9.2	Total Counters (S6.8.1)	78
8.7.9.3	Trip Counters (S6.8.2)	79
8.7.9.4	Resetting the Trip Counters	79
8.7.9.5	Software (S6.8.3)	79
8.7.9.6	Applications (S6.8.4)	79
8.7.9.7	Examining the Application Page	80
8.7.9.8	Hardware (S6.8.5)	80
8.7.9.9	Checking the Status of an Option Board	80
8.7.9.10	Debug Menu (S6.8.7)	80
8.8	Using the Expander Board Menu	81

8.8.1	Expander Board Menu	81
8.8.2	Examining the Connected Option Boards	81
8.8.3	Finding the Option Board Parameters	81
8.9	Further Control Panel Functions	81
9	Commissioning	82
9.1	Safety Checks before Starting the Commissioning	82
9.2	Commissioning the Inverter	83
9.3	Measuring the Cable and Motor Insulation	83
9.3.1	Insulation Checks of the Motor Cable	83
9.3.2	Insulation Checks of the DC Supply Cable	83
9.3.3	Insulation Checks of the Motor	84
9.4	Checks after Commissioning	84
9.4.1	Testing the Inverter after Commissioning	84
9.4.2	RUN Test without Load	84
9.4.3	Start-up Test	84
9.4.4	Motor Run Checklist	85
10	Maintenance	86
10.1	Preventive Maintenance Recommendations	86
10.2	Reforming the Capacitors	88
11	Fault Tracing	90
11.1	General Information on Fault Tracing	90
11.2	Resetting a Fault	90
11.3	Creating Service Info File	90
12	Specifications	92
12.1	Weights of the Inverter	92
12.2	Dimensions	92
12.2.1	Dimensions for FI4–FI8	93
12.2.2	Dimensions for Flange Mounting, FI4–FI6	94
12.2.3	Dimensions for Flange Mounting, FI7–FI8	95
12.3	Cable and Fuse Sizes	97
12.3.1	Fuse Sizes for 465–800 V DC (380–500 V AC)	97
12.3.2	Fuse Sizes for 640–1100 V DC (525–690 V AC)	98
12.3.3	Cable Sizes for 465–800 V DC (380–500 V AC)	98
12.3.4	Cable Sizes for 640–1100 V DC (525–690 V AC)	99
12.4	Cable Stripping Lengths	99
12.5	Tightening Torques for Cover Screws	100

12.6	Tightening Torques of the Terminals	101
12.7	Power Ratings	101
12.7.1	Overload Capability	101
12.7.2	Power Ratings for 465–800 V DC (380–500 V AC)	102
12.7.3	Power Ratings for 640–1100 V DC (525–690 V AC)	103
12.8	Technical Data	104
12.9	DC Currents and DC Link Capacitance	106
12.9.1	DC Currents, Supply Voltage 465–800 V DC	107
12.9.2	DC Currents, Supply Voltage 640–1100 V DC	107
12.9.3	DC Link Capacitance	108
12.10	Faults and Alarms	108

1 Introduction

1.1 Purpose of this Operating Guide

This operating guide provides information for safe installation and commissioning of the AC drive. It is intended for use by qualified personnel.

Read and follow the instructions to use the drive safely and professionally.

Pay particular attention to the safety instructions and general warnings. Always keep this operating guide with the drive.

1.2 Additional Resources

Other resources are available to understand advanced AC drive functions and programming.

- The VACON[®] NX manuals provide greater detail on working with parameters and show many application examples.
- The VACON[®] NX I/O Boards User Manual gives more information on the I/O boards and their installation.
- Instructions for operation with option boards and other optional equipment.

Supplementary publications and manuals are available from Danfoss.

NOTE! Download the English and French product manuals with applicable safety, warning and caution information from <https://www.danfoss.com/en/service-and-support/>.

REMARQUE Vous pouvez télécharger les versions anglaise et française des manuels produit contenant l'ensemble des informations de sécurité, avertissements et mises en garde applicables sur le site <https://www.danfoss.com/en/service-and-support/>.

1.3 Disposal

Do not dispose of equipment containing electrical components together with domestic waste. Collect it separately in accordance with local and currently valid legislation.



1.4 Type Approvals and Certifications

The following list is a selection of possible type approvals and certifications for Danfoss drives:

Table 1: Type Approvals and Certifications

ClassNK			

N O T I C E

The specific approvals and certification for the drive are on the nameplate of the drive. For more information, contact the local Danfoss office or partner.

1.5 Start up Quick Guide

Do at minimum these procedures during the installation and commissioning.

If there are problems, speak to the local distributor.

VACON Ltd is not responsible for the use of the inverters against the instructions.

Procedure

1. Check that the delivery agrees to the order, see [4.1 Checking the Delivery](#).
2. Before starting the commissioning, read carefully the safety instructions in [2.2 Danger and Warnings](#) and [2.3 Cautions and Notices](#).
3. Before the mechanical installation, check the minimum clearances around the unit ([5.2.2 Cooling of FI4 to FI8](#)) and check the ambient conditions in [12.8 Technical Data](#).
4. Check the dimensions of the motor cable, DC supply cable, mains fuses, and check the cable connections. Read [6.1 Cable Connections](#), [6.3 EMC-compliant Installation](#), and [6.2 Grounding](#).
5. Obey the installation instructions, see [6.5 Installing the Cables](#).
6. Find information on the control connections in [7.3.2 Control Terminals on OPTA1](#).
7. If the start-up wizard is active, select the language of the control panel and the application. Accept the selections with the Enter button. If the start-up wizard is not active, obey the instructions a and b.
 - a. Select the language of the control panel from the Menu M6, page 6.1. For instructions, see [8.7.3 Changing the Language](#).
 - b. Select the application from the Menu M6, page 6.2. For instructions, see [8.7.4 Changing the Application](#).
8. All parameters have factory default values. To make sure that the AC drive operates correctly, make sure that these group G2.1 parameters have the same data as the nameplate. For more information on the parameters in the list, see the VACON[®] All in One Application Manual.

- Nominal voltage of the motor
- Nominal frequency of the motor
- Nominal speed of the motor
- Nominal current of the motor
- Motor cos phi

9. Obey the commissioning instructions, see [9.2 Commissioning the Inverter](#).

The VACON[®]NX Inverter is ready for operation.

2 Safety

2.1 Safety Symbols

The following symbols are used in this guide:

⚠ D A N G E R ⚠

Indicates a hazardous situation which, if not avoided, will result in death or serious injury.

⚠ W A R N I N G ⚠

Indicates a hazardous situation which, if not avoided, could result in death or serious injury.

⚠ C A U T I O N ⚠

Indicates a hazardous situation which, if not avoided, could result in minor or moderate injury.

N O T I C E

Indicates information considered important, but not hazard-related (for example, messages relating to property damage).

2.2 Danger and Warnings

⚠ D A N G E R ⚠

SHOCK HAZARD FROM INVERTER POWER UNIT COMPONENTS

The inverter power unit components are live when the inverter is connected to DC supply. A contact with this voltage can lead to death or serious injury.

- Do not touch the components of the power unit when the inverter is connected to DC supply. Before connecting the inverter to DC supply, make sure that the covers of the inverter are closed.

⚠ D A N G E R ⚠

SHOCK HAZARD FROM INVERTER TERMINALS

The motor terminals U, V, W, the brake resistor terminals, or the DC terminals are live when the inverter is connected to DC supply, also when the motor does not operate. A contact with this voltage can lead to death or serious injury.

- Do not touch the motor terminals U, V, W, the brake resistor terminals, or the DC terminals when the inverter is connected to DC supply. Before connecting the inverter to DC supply, make sure that the covers of the inverter are closed.

⚠ D A N G E R ⚠

SHOCK HAZARD FROM DC LINK OR EXTERNAL SOURCE

The terminal connections and the components of the drive can be live 5 minutes after the inverter is disconnected from the DC supply and the motor has stopped. Also the load side of the inverter can generate voltage. A contact with this voltage can lead to death or serious injury.

- Before doing electrical work on the inverter:
 - Disconnect the inverter from the DC supply and make sure that the motor has stopped.
 - Lock out and tag out the power source to the inverter.
 - Make sure that no external source generates unintended voltage during work.
 - Wait 5 minutes before opening the cabinet door or the cover of the inverter.
 - Use a measuring device to make sure that there is no voltage.

⚠ WARNING ⚠

SHOCK HAZARD FROM INVERTER CONTROL TERMINALS

The control terminals can have a dangerous voltage also when the drive is disconnected from DC supply. A contact with this voltage can lead to injury.

- Make sure that there is no voltage in the control terminals before touching the control terminals.

⚠ WARNING ⚠

ACCIDENTAL MOTOR START

When there is a power-up, a power break, or a fault reset, the motor starts immediately if the start signal is active, unless the pulse control for Start/Stop logic is selected. If the parameters, the applications or the software change, the I/O functions (including the start inputs) can change. If you activate the auto reset function, the motor starts automatically after an automatic fault reset. See the Application Guide. Failure to ensure that the motor, system, and any attached equipment are ready for start can result in personal injury or equipment damage.

- Disconnect the motor from the drive if an accidental start can be dangerous. Make sure that the equipment is safe to operate under any condition.

⚠ WARNING ⚠

LEAKAGE CURRENT HAZARD

Leakage currents exceed 3.5 mA. Failure to ground the drive properly can result in death or serious injury.

- Ensure the correct grounding of the equipment by a certified electrical installer.

⚠ WARNING ⚠

SHOCK HAZARD FROM PE CONDUCTOR

The drive can cause a DC current in the PE conductor. Failure to use a residual current-operated protective (RCD) device Type B or a residual current-operated monitoring (RCM) device can lead to the RCD not providing the intended protection and therefore can result in death or serious injury.

- Use a type B RCD or RCM device on the mains side of the drive.

2.3 Cautions and Notices

⚠ CAUTION ⚠

DAMAGE TO THE AC DRIVE FROM INCORRECT MEASUREMENTS

Doing measurements on the AC drive when it is connected to mains can damage the drive.

- Do not do measurements when the AC drive is connected to mains.

⚠ CAUTION ⚠

DAMAGE TO THE AC DRIVE FROM INCORRECT SPARE PARTS

Using spare parts that are not from the manufacturer can damage the drive.

- Do not use spare parts that are not from the manufacturer.

⚠ CAUTION ⚠

DAMAGE TO THE AC DRIVE FROM INSUFFICIENT GROUNDING

Not using a grounding conductor can damage the drive.

- Make sure that the AC drive is always with a grounding conductor that is connected to the grounding terminal that is identified with the PE symbol.

⚠ CAUTION ⚠**CUT HAZARD FROM SHARP EDGES**

There can be sharp edges in the AC drive that can cause cuts.

- Wear protective gloves when mounting, cabling, or doing maintenance operations.

⚠ CAUTION ⚠**BURN HAZARD FROM HOT SURFACES**

Touching surfaces, which are marked with the 'hot surface' sticker, can result in injury.

- Do not touch surfaces which are marked with the 'hot surface' sticker.

NOTICE**DAMAGE TO THE AC DRIVE FROM STATIC VOLTAGE**

Some of the electronic components inside the AC drive are sensitive to ESD. Static voltage can damage the components.

- Remember to use ESD protection always when working with electronic components of the AC drive. Do not touch the components on the circuit boards without proper ESD protection.

NOTICE**DAMAGE TO THE AC DRIVE FROM MOVEMENT**

Movement after installation can damage the drive.

- Do not move the AC drive during operation. Use a fixed installation to prevent damage to the drive.

NOTICE**DAMAGE TO THE AC DRIVE FROM INCORRECT EMC LEVEL**

The EMC level requirements for the AC drive depend on the installation environment. An incorrect EMC level can damage the drive.

- Before connecting the AC drive to the mains, make sure that the EMC level of the AC drive is correct for the mains.

NOTICE**RADIO INTERFERENCE**

In a residential environment, this product can cause radio interference.

- Take supplementary mitigation measures.

NOTICE**MAINS CONNECTION DEVICE**

If the AC drive is used as a part of a machine, the machine manufacturer must supply a mains disconnection device (refer to EN 60204-1).

NOTICE**MALFUNCTION OF FAULT CURRENT PROTECTIVE SWITCHES**

Because there are high capacitive currents in the AC drive, it is possible that the fault current protective switches do not operate correctly.

N O T I C E**VOLTAGE WITHSTAND TESTS**

Doing voltage withstand tests can damage the drive.

- Do not do voltage withstand tests on the AC drive. The manufacturer has already done the tests.

3 Product Overview

3.1 Introduction

The figure presents the block diagram of the VACON[®]NX inverter. The inverter mechanically consists of 2 units: the Power Unit and the Control Unit.

The Power Unit contains an inverter bridge which consists of IGBT switches and produces a symmetrical, 3-phase PWM-modulated AC voltage to the motor. To protect the DC-link capacitors, the Power Unit also contains a charging circuit for controlled DC-link charge. Use the B+ and DC-terminals to bypass the charging circuit.

The Motor and Application Control Block is based on microprocessor software. The microprocessor controls the motor based on the information it receives through measurements, parameter settings, control I/O, and control panel.

The motor and application control block controls the motor control ASIC which, in turn, calculates the IGBT positions. Gate drivers amplify these signals for driving the IGBT inverter bridge.

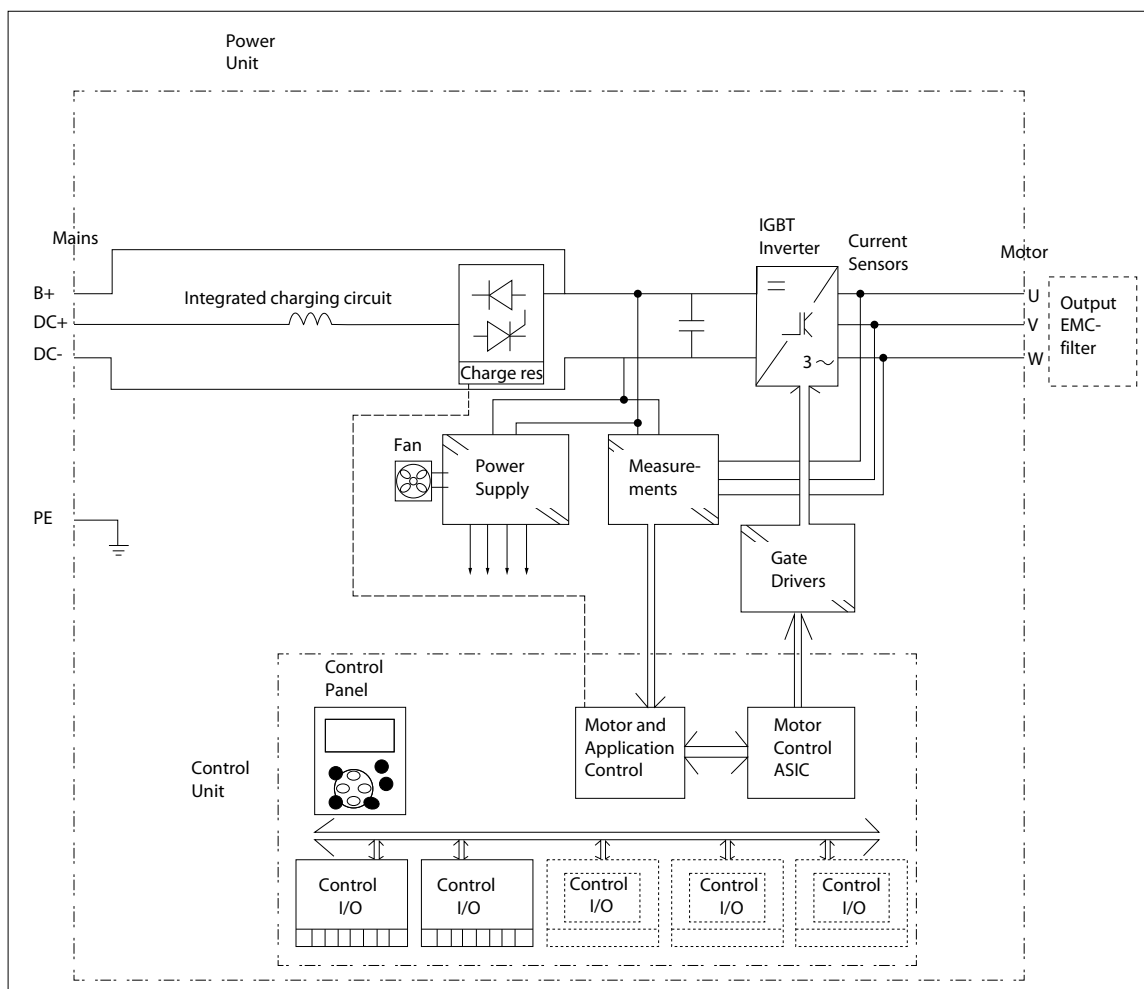

e30bh433.10

Illustration 1: Block Diagram of VACON[®]NX Inverter

The control panel constitutes a link between the user and the inverter. The control panel is used for parameter setting, reading status data and giving control commands. It is detachable and can be operated externally and is connected via a cable to the inverter. Instead of the control panel, a PC can be used to control the inverter when connected through a similar cable (VACON[®]RS232PC-1.5M).

The basic control interface and the parameters (the Basic Application) are easy to use. If a more versatile interface or parameters are required, a more suitable application can be selected from the "All in One" Application Package. See the "All in One" Application Manual for more information on the different applications.

Optional I/O expander boards that increase the number of inputs and outputs to be used are also available. For more information, contact the Manufacturer or your local distributor.

3.2 Intended Use

The drive is an electronic motor controller intended for:

- Regulation of motor speed in response to system feedback or to remote commands from external controllers. A power drive system consists of the AC drive, the motor, and equipment driven by the motor.
- System and motor status surveillance.

The drive can also be used for motor overload protection.

VACON[®]NXP drive can be used as programmable logic controller (PLC) in many applications due to extensive I/O and fieldbus options and easy programmability. Custom application development can be done with VACON[®]Programming tool and standard PLC programming languages defined in the IEC 61131/3.

Depending on the configuration, the drive can be used in standalone applications or form part of a larger appliance or installation.

The drive is allowed for use in residential, industrial, and commercial environments in accordance with local laws and standards.

N O T I C E

In a residential environment, this product can cause radio interference, in which case supplementary mitigation measures can be required.

Foreseeable misuse

Do not use the drive in applications which are non-compliant with specified operating conditions and environments. Ensure compliance with the conditions specified in [12.8 Technical Data](#).

3.3 Version History

This guide is regularly reviewed and updated. All suggestions for improvement are welcome.

The original language of this guide is English.

Table 2: Version History

Edition	Remarks
DPD00908E	Chapter 10.1 Maintenance Schedule replaced with Preventative Maintenance. Corrections and clarifications to several tables and images.

3.4 Standard Features of VACON NX Inverters

Table 3: Standard Features of VACON[®]NX Inverters F14-F18

	INU
Sales code	NXI_AAAA 5/6
Standard features for F14, F16, and F17	DC connection
	IP21
	Air cooling
	Integrated charging
	Alphanumeric control panel (in the front end of the module)
	I/O modules A1 & A2
	Standard board
Safety CE/UL	
Sales code	NXI_AAAA 5/6
Standard features for F18	DC connection

	INU
	IP00
	Air cooling
	Integrated charging
	Alphanumeric control panel (in the front end of the module)
	I/O modules A1 & A2
	Standard board
	Safety CE/UL

3.5 Package Label

The package label gives detailed information about the delivery.

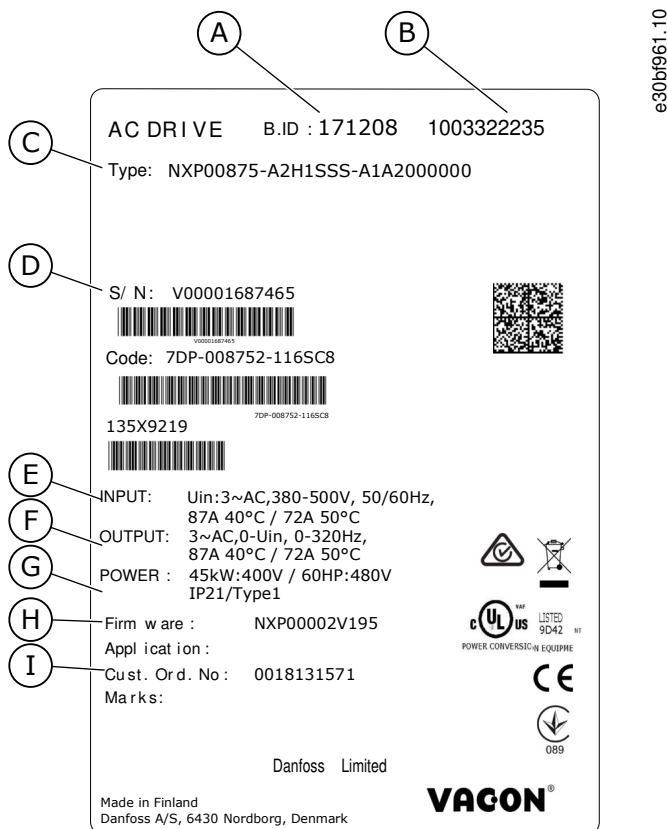

Illustration 2: Package Label of VACON®NX AC Drives (Example)

A	The batch ID	F	The nominal output current
B	The order number of VACON®	G	The protection rating
C	The type code	H	The firmware code
D	The serial number	I	The order number of the customer
E	The mains voltage		

3.6 Description of the Type Code

The type code of VACON® is made of standard codes and optional codes. Each part of the type code agrees to the data in the order.

Example

The code can have this format, for example:

- NXI00035-A2T0ISF-A1A2C30000+DNOT

Table 4: Description of the Type Code

Code	Description
VACON	This part is same for all the products.
NXI	The product range: NXI = VACON® NX Inverter
0205	The drive rating in amperes. For example, 0205 = 205 A
5	The mains voltage: <ul style="list-style-type: none"> • 5 = 465–800 V DC (380–500 V AC) • 6 = 640–1100 V DC (525–690 V AC)
A	The control panel: <ul style="list-style-type: none"> • A = standard (text display) • B = no local control panel • F = dummy keypad • G = graphical display
0	The protection rating: <ul style="list-style-type: none"> • 0 = IP00 • 2 = IP21 • 5 = IP54
T	The EMC emission level: <ul style="list-style-type: none"> • T = complies with the standard IEC/EN 61800-3 + A1 when used in IT networks (C4).
0	The brake chopper: ⁽¹⁾ <ul style="list-style-type: none"> • 0 = No brake chopper
ISF	The hardware changes: <ul style="list-style-type: none"> • The supply, the first letter (Xxx): <ul style="list-style-type: none"> - C = INU - with integrated charging circuit - I = INU - no charging circuit - 2 = AFE module

Code	Description
	<ul style="list-style-type: none"> - 5 = AFE module + LCL Filter - 8 = BCU brake chopper unit • The mounting, the second letter: (xXx): <ul style="list-style-type: none"> - S = Standard air-cooled drive - U = Standard air-cooled power unit - external supply for main fan • The boards, the third letter (xxX): <ul style="list-style-type: none"> - S = Direct connection, standard boards, FI4-FI8 - V = Direct connection, varnished boards, FI4-FI8 - F = Fiber connection, standard boards - G = Fiber connection, varnished boards
A1A2A5E900	<p>The option boards. 2 characters for each slot. 00 = the slot is not used</p> <p>The option board abbreviations:</p> <ul style="list-style-type: none"> • A = basic I/O board • B = expander I/O board • C = special board • D = fieldbus board • E = fieldbus board <p>For example, E3 = PROFIBUS DP</p>
+DNOT	<p>The optional codes. There are many options.</p> <p>The options that are related to ordering of paper manuals are:</p> <ul style="list-style-type: none"> • +DNOT = No paper User Guides, only Quick Guide and Safety Guide • +DPAP = With English paper User Guides • +DPAP+DLDE = With German paper User Guides

¹ Not used for NX Inverters.

3.7 Enclosure Sizes

Example

The codes for nominal current and nominal mains voltage are part of the type code (see [3.6 Description of the Type Code](#)) on the package label (see [3.5 Package Label](#)). Use these values to find out the enclosure size of the AC drive from the table.

In the example "NXI00035-A2H1SSS-A1A2C30000+DNOT", the code for nominal current is 0003 and the code for nominal mains voltage is 5.

Table 5: Enclosure Sizes

Nominal mains voltage	Nominal current	Enclosure size
5 (465–800 V DC, 380–500 V AC)	0004	FI4
	0009	
	0012	
	0016	FI6
	0022	
	0031	

Nominal mains voltage	Nominal current	Enclosure size
	0038	F17
	0045	
	0061	
	0072	
	0087	
	0105	
	0140	
6 (640–1100 V DC, 525–690 V AC)	0004	F16
	0005	
	0007	
	0010	
	0013	
	0018	
	0022	
	0027	
	0034	
	0041	
	0052	
	0062	F18
	0080	
	0100	

3.8 Available Protection Ratings

Table 6: Available Protection Ratings

Mains voltage	Enclosure size	IP21 (UL Type 1)	IP00
350–500 V	FI4-FI7	x	
350–500 V	FI8		x
525–690 V	FI4-FI7	x	x
525–690 V	FI8		x

3.9 Available EMC Classes

The EMC Directive provides that the electrical apparatus must not excessively disturb the environment it is used in. It also requires that the electrical apparatus must have an adequate level of immunity toward other disturbances from the same environment.

The compliance of VACON[®]NX Inverters with the EMC Directive is verified with Technical Construction Files (TCF) and checked and approved by SGS FIMKO, which is a Notified Body. The Technical Construction Files are used to authenticate the conformity of VACON[®]NX Inverters with the Directive. It is because testing such a large product family in a laboratory environment is impossible. Testing is difficult also because the combinations of installation vary greatly.

All factory-delivered VACON[®]NX Inverters are Class T (Category C4) equipment which fulfills EMC immunity requirements EN 50082-1, 50082-2 and IEC/EN 61800-3.

Class T (Category C4):

Class T equipment have a small ground leakage current and can be used with floating DC input. If they are used with other supplies, no EMC requirements are complied with.

NOTICE

RADIO INTERFERENCE

In a residential environment, this product can cause radio interference.

- Take supplementary mitigation measures.

3.10 Control Panel

3.10.1 Keypad

The VACON[®]keypad has 9 buttons with which to control the AC drive (and motor), set parameters, and monitor values.

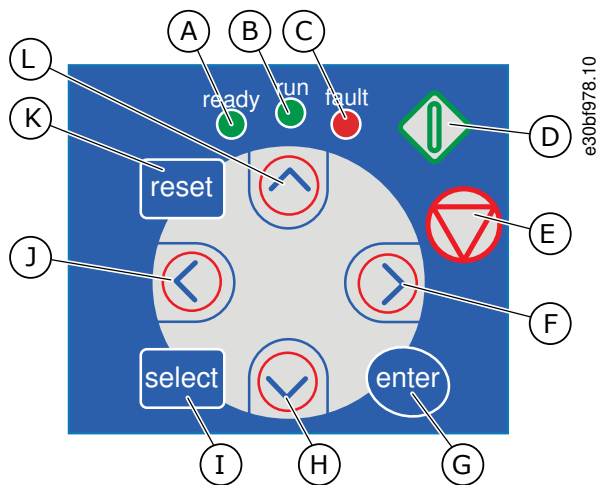

Illustration 3: Keypad Buttons for VACON[®]NXP

A	The [ready] LED is on when the AC power is connected to the drive and no faults are active. At the same time, the drive status indication shows <i>READY</i> .	G	The [enter] button. Use it to accept a selection, reset the fault history (push for 2–3 s).
B	The [run] LED is on when the drive operates. The LED blinks when the Stop button is pushed and the drive ramps down.	H	The Browser button Down. Use it to scroll the main menu and the pages of different submenus and to decrease a value.
C	The [fault] LED blinks when the AC drive is stopped because of dangerous conditions (Fault Trip). See 8.5.1 Finding the Active Faults Menu .	I	The [select] button. Use it to move between 2 last displays, for example, to see how new value changes some other value.
D	The Start button. When the keypad is the active control mode, this button starts the motor. See 8.4.3 Changing the Control Mode .	J	The Menu button Left. Use it to move back in the menu, move the cursor left (in the Parameter menu).
E	The Stop button. The button stops the motor (unless the stop is disabled by the parameter R3.4/R3.6). See 8.4.2 Keypad Control Parameters M3 .	K	The [reset] button. Use it to reset a fault.
F	The Menu button Right. Use it to move forward in the menu, move the cursor right (in the parameter menu) and to go to the edit mode.	L	The Browser button Up. Use it to scroll the main menu and the pages of different submenus and to increase a value.

3.10.2 Display

The following figure describes the sections of the display.

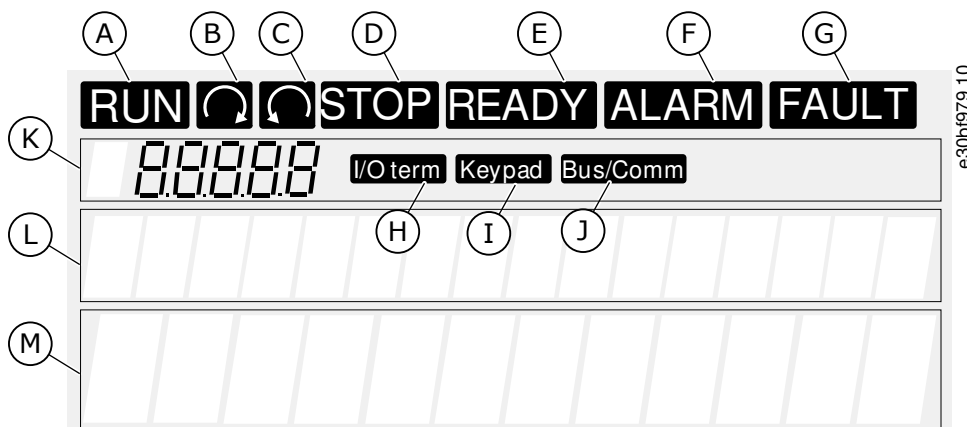

Illustration 4: Display Indications

A	The motor is in RUN state. The indication starts to blink when a stop command is given and blinks while the speed continues to decrease.	H	The I/O terminals is the active control mode.
B	The motor rotation direction is forward.	I	The control panel is the active control mode.
C	The motor rotation direction is reverse.	J	The fieldbus is the active control mode.
D	The drive does not operate.	K	The location indication. The line shows the symbol and number of the menu, parameter, and so on. For example, <i>M2</i> = Menu 2 (Parameters) or <i>P2.1.3</i> = Acceleration time.
E	The AC power is on.	L	The description line. The line shows the description of the menu, value, or fault.
F	An alarm is given.	M	The value line. The line shows the numerical and text values of references, parameters, and so on. It also shows the number of submenus that are available in each menu.
G	A fault is given and the AC drive is stopped.		

The drive status indicators (A–G) give information about the status of the motor and the AC drive.

The control mode indications (H, I, J) show the selection of the control mode. The control mode tells from where the START/STOP commands are given and reference values are changed. To make this selection, go to the Keypad control menu (M3) (see [8.4.3 Changing the Control Mode](#)).

The three text lines (K, L, M) give information about the current location in the menu structure and the operation of the drive.

3.10.3 Basic Menu Structure

The data of the AC drive is in menus and submenus. The figure shows the basic menu structure of the AC drive.

This menu structure is only an example and the contents and items can vary depending on the application in use.

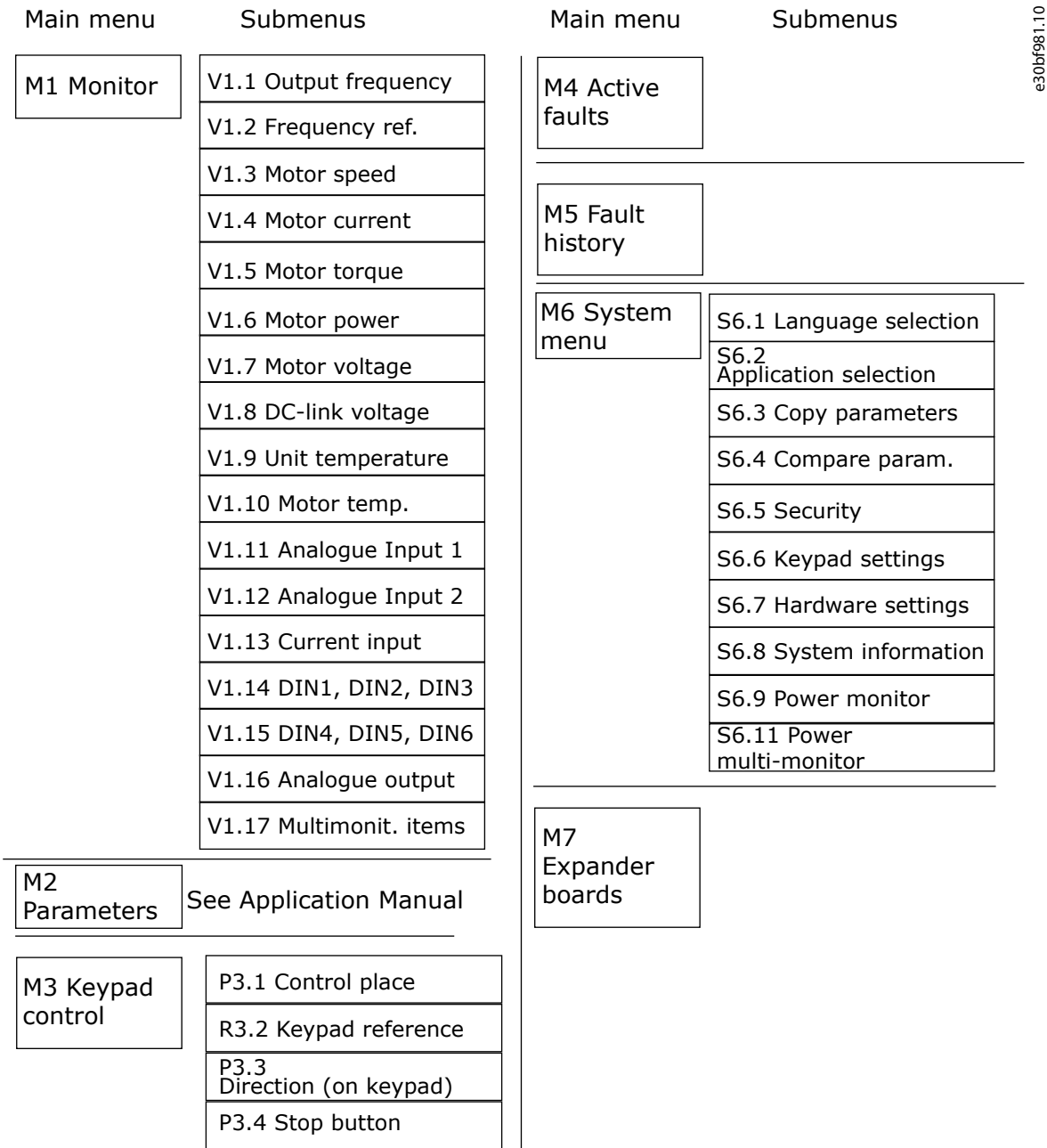

e30bf981.10

Illustration 5: Basic Menu Structure of the AC Drive

4 Receiving the Delivery

4.1 Checking the Delivery

Before a VACON[®] AC drive is sent to the customer, the manufacturer makes many tests on the drive.

Procedure

1. After removing the packaging, examine the drive for transport damages.
 - If the drive was damaged during the shipping, speak to the cargo insurance company or the carrier.
2. To make sure that the delivery is correct, compare the order data to the data on the package label, see [3.5 Package Label](#).
 - If the delivery does not agree with the order, contact the vendor immediately.
3. To make sure that the contents of the delivery is correct and complete, compare the type code of the product to the type code, see [3.6 Description of the Type Code](#).
4. Check that the accessories bag contains the items shown in the figure. These accessories are part of the electrical installation. The contents of the accessories bag is different for different enclosure sizes and protection ratings.
 - FR4/FI4–FR4-FR6: [4.1.1 Accessories for FR4/FI4–FR6/FI6](#)
 - FR7/FI7–FR8/FI8: [4.1.2 Accessories for FR7/FI7–FR8/FI8](#)
 - FR10–FR11 Standalone: [4.1.3 Accessories for FR10–FR11 Standalone](#)
 - Flange mounting accessories kits: see details in Flange Mounting Kit for FR4–FR6 Installation Manual or Flange Mounting Kit for FR7–FR9 Installation Manual.

4.1.1 Accessories for FR4/FI4–FR6/FI6

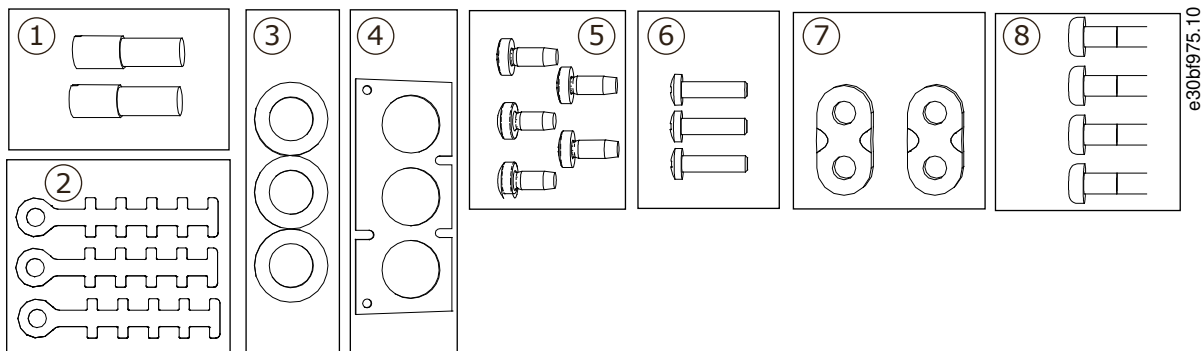

Illustration 6: Contents of the Accessories Bag for FR4–FR6/FI4–FI6

1	The grounding terminals (FR4/FI4, FR5), 2 pieces	5	Screws, M4x10, 5 pieces
2	The grounding clamps for control cable, 3 pieces	6	Screws, M4x16, 3 pieces
3	The rubber grommets (sizes vary from class to class), 3 pieces	7	The grounding clamps for grounding conductor (FR6/FI6), 2 pieces
4	The cable entry plate	8	The grounding screws M5x16 (FR6/FI6), 4 pieces

4.1.2 Accessories for FR7/FI7–FR8/FI8

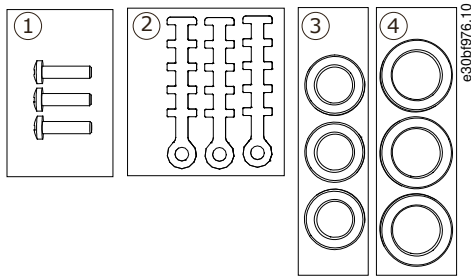

Illustration 7: Contents of the Accessories Bag for FR7–FR8/FI7–FI8

1	Screws, M4x16, 3 pieces	3	The rubber grommets GD21 (FR7/FI7 IP54/UL Type 12), 3 pieces / (FR8/FI8), 6 pieces
2	The grounding clamps for control cable, 3 pieces	4	The rubber grommets GDM36 (FR7/FI7), 3 pieces

4.1.3 Accessories for FR10–FR11 Standalone

The cabinet door key is attached to the lifting rail at the top of the AC drive.

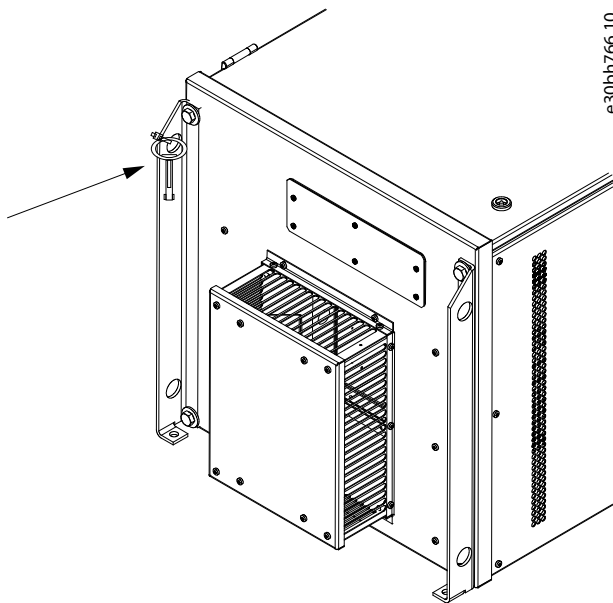

Illustration 8: The Cabinet Door Key Location at Delivery

4.2 Storing the Product

If the product has to be stored before installing it, follow these instructions.

Procedure

1. If the AC drive must be stored before using it, make sure that the ambient conditions agree to the following:

- Storage temperature: -40...+70° C (-40...+158° F)
- Relative humidity: 0–95%, no condensation

2. If the AC drive must be kept in storage for a long time, connect the power to the AC drive each year. Keep the power on for a minimum of 2 hours.
3. If the storage time is more than 12 months, charge the electrolytic DC capacitors with caution. To reform the capacitors, obey the instructions in [10.2 Reforming the Capacitors](#).

We do not recommend a long storage time.

4.3 Lifting the Product

Lifting instructions depend on the weight of the AC drive. It can be necessary to use a lifting device to move the drive from its package.

Procedure

1. Check the weight of the inverter, see [12.1 Weights of the Inverter](#).
2. To lift the AC drives larger than FR7/F17 out of the package, use a jib crane.

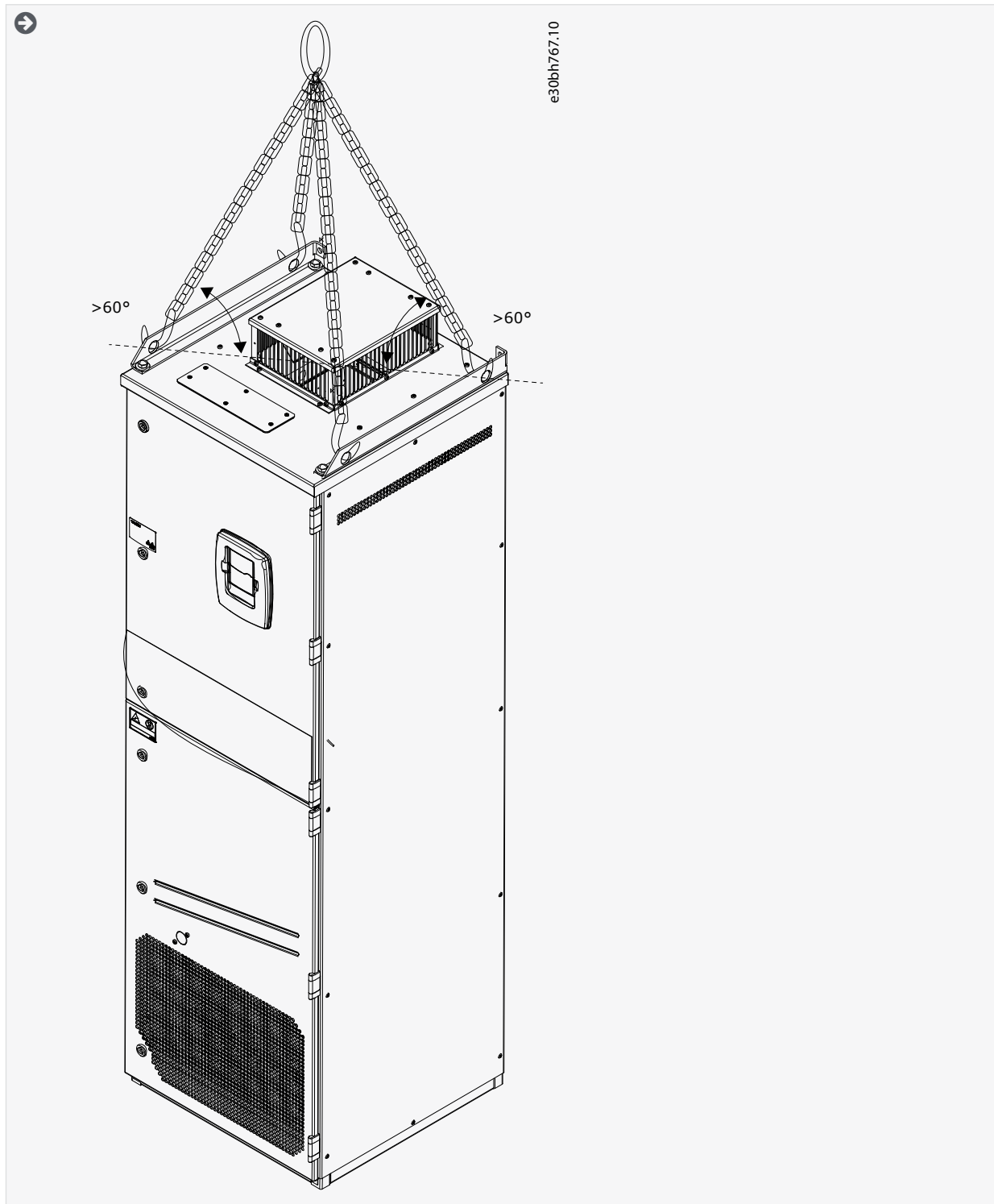

3. After lifting the drive, check for signs of damage on the drive.

4.4 Using the Product Modified Label

In the accessories bag, there is also a "product modified" label. The function of the label is to tell the service personnel about the changes that are made in the AC drive.

Drive modified:		e30b977.10	
<input type="checkbox"/>	Option board: NXOPT..... in slot: A B C D E		Date:..... Date:.....
<input type="checkbox"/>	IP54 upgrade/Collar		Date:.....
<input type="checkbox"/>	EMC level modified: H/L to T		Date:.....

Illustration 9: The Product Modified Label

Procedure

1. Attach the label on the side of the AC drive, in a place where it is easy to find.
2. If changes are made to the AC drive, write the change and date on the label.

5 Mounting the Unit

5.1 Environmental Requirements

5.1.1 General Environmental Requirements

In environments with airborne liquids, particles, or corrosive gases, ensure that the protection rating of the equipment matches the installation environment. Failure to meet requirements for ambient conditions can reduce the lifetime of the AC drive. Ensure that requirements for humidity, temperature, and altitude are met.

Vibration and shock

The AC drive complies with requirements for units mounted on the walls and floors of production premises, and in panels bolted to walls or floors.

AC drive is suitable for marine installations.

For detailed ambient conditions specifications, see [12.8 Technical Data](#).

Installation requirements:

- Make sure that there is sufficiently free space around the AC drive for cooling, see [5.2.2 Cooling of F14 to F18](#).
- Some free space is also necessary for maintenance.
- Make sure that the mounting surface is sufficiently flat.

5.1.2 Ambient Temperature and Derating

The power rating of the unit is valid for an ambient temperature of 40 °C (104 °F). If the device is to be used in higher ambient temperatures, its power rating must be subjected to derating.

Use the following formula to calculate the reduced power:

$$P_{de} = P_n * ((100 \% - (t - 40\text{ °C}) * x) / 100)$$

Legend:

- P_n = nominal power of the unit
- t = ambient temperature
- x = derating coefficient, see the following list:
 - in ambient temperature of 40–50 °C (104–122 °F), use derating factor 1.5%/1 °C (°F)
 - For 50–55 °C (122–131 °F) ambient temperatures use derating factor 2.5% / 1 °C (°F).

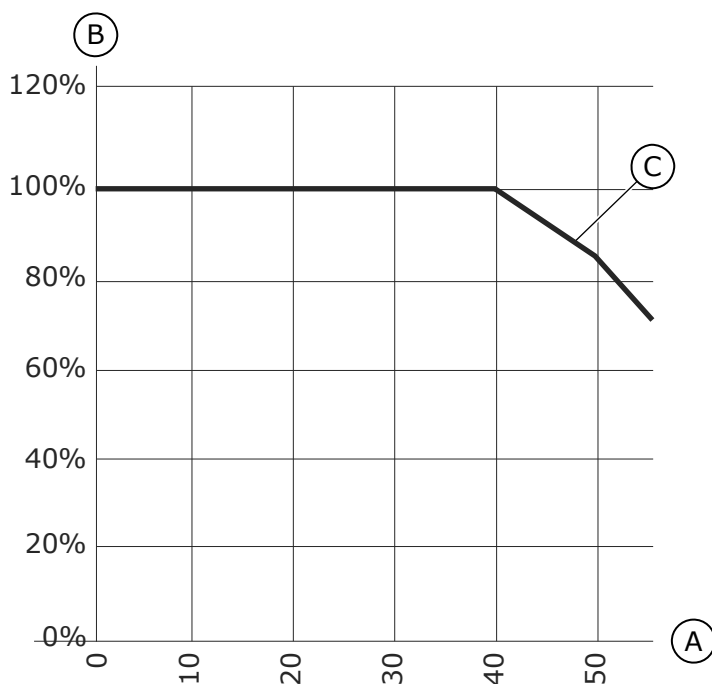

e30bh393.20

Illustration 10: Derating and the Ambient Temperature

A	Ambient temperature, °C	C	Loadability %
B	Loadability, %		

5.1.3 High Altitude Installation

The density of air decreases when the altitude increases and the pressure decreases. When the air density decreases, the thermal capacity decreases (that is, less air removes less heat) and the resistance to electric field (breakdown voltage/distance) decreases. The full thermal performance of VACON[®]NX AC drives is designed for installation up to 1000 m altitude. The electric insulation is designed for installations up to 3000 m altitude (check details for different sizes in Technical Data).

Higher installation locations are possible, when obeying the derating guidelines in this chapter.

For permitted maximum altitudes, see [12.8 Technical Data](#).

Above 1000 m, decrease the limited maximum load current by 1% for each 100 m.

For information on option boards and I/O signals and relay outputs, see VACON[®]NX I/O Boards User Manual.

Example

For example, at 2500 m altitude, decrease the load current down to 85% of the rated output current (100% – (2500–1000 m) / 100 m x 1% = 85%).

When using fuses at high altitudes, the cooling effect of the fuse decreases as the density of the atmosphere decreases.

When using fuses above 2000 meters, the continuous rating of the fuse:

$$I = I_n * (1 - (h - 2000) / 100 * 0.5 / 100)$$

Where

I = Current rating at high altitude

I_n = Rated current of a fuse

h = Altitude in meters

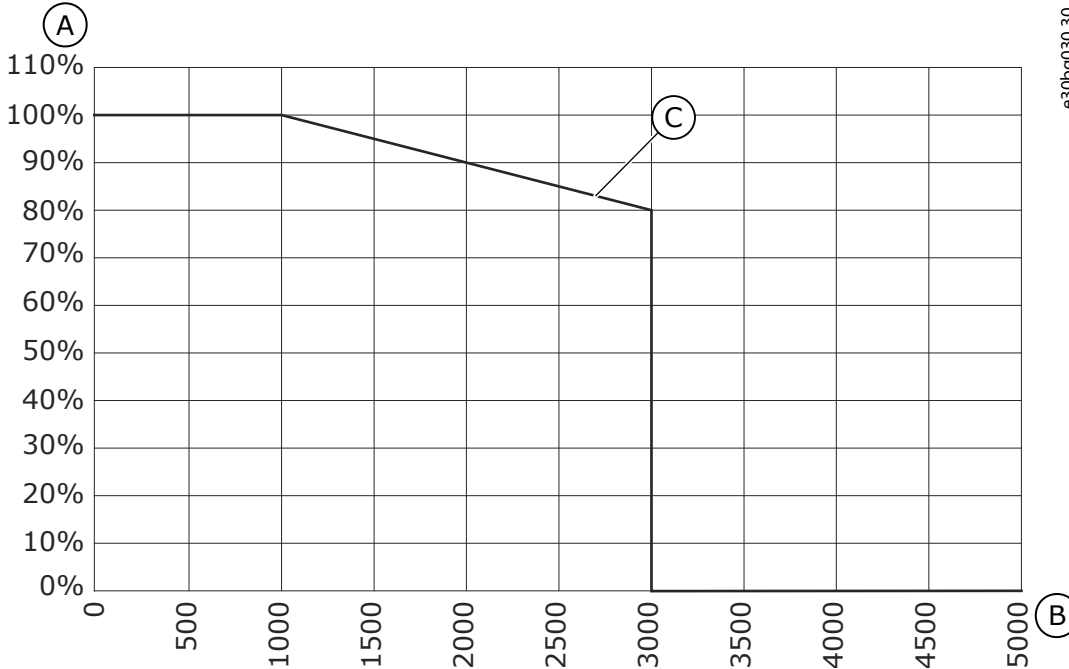

Illustration 11: Loadability in High Altitudes

A	Loadability, %	C	Loadability
B	Altitude, meters		

5.2 Cooling Requirements

5.2.1 General Cooling Requirements

The AC drive produces heat in operation. The fan moves air and decreases the temperature of the drive. Make sure that there is sufficiently free space around the drive.

Make sure that the temperature of the cooling air does not go above the maximum ambient operating temperature or below the minimum ambient operating temperature of the drive.

5.2.2 Cooling of FI4 to FI8

If many AC drives are installed above each other, the necessary free space is C + D (see [Illustration 12](#)). Make also sure that the outlet air from the lower drive goes to a different direction than the air intake of the top drive.

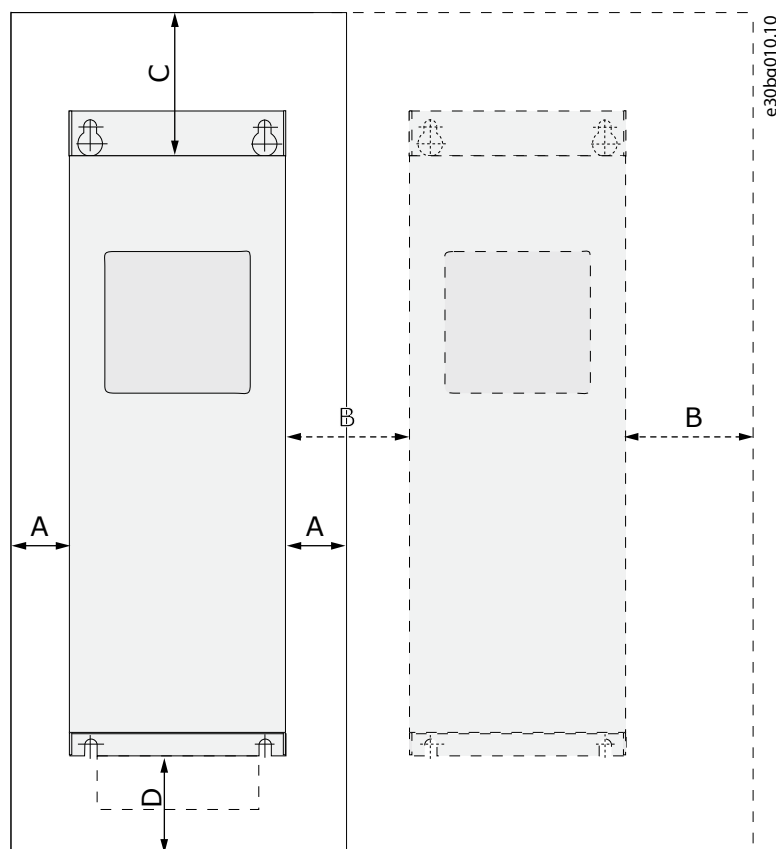

Illustration 12: Installation Space

A	The clearance around the drive (see also B and C)	C	The free space above the drive
B	The distance from a drive to a second drive, or the distance to the cabinet wall	D	The free space below the drive

Table 7: Minimum Clearances around the AC Drive in mm (in inch)

Drive type	A	B	C	D
0004 5-0012 5	20	20	100	50

Drive type	A	B	C	D
	(0.79)	(0.79)	(3.94)	(1.97)
0016 5-0048 5 0004 6-0034 6	30 (1.18)	20 (0.79)	160 (6.30)	80 (3.15)
0061 5-0105 5 0041 6-0052 6	80 (3.15)	80 (3.15)	300 (11.81)	100 (3.94)
0140 5 0062 6-0100 6	80 (3.15) ⁽¹⁾	80 (3.15)	300 (11.81)	200 (7.87)

¹ To change the fan with the motor cables connected, the necessary clearance on the 2 sides of the drive is 150 mm (5.91 inch).

Table 8: Required Cooling Air

Drive type	Greatest possible heat loss (kW)	The quantity of cooling air [m ³ /h]	The quantity of cooling air [CFM]
0004 5-0012 5	0.2	70	41.2
0016 5-0048 5 0004 6-0034 6	1 0.75	425	250
0061 5-0105 5 0041 6-0052 6	1.9 1.2	425	250
0140 5 0062 6-0100 6	3.3 2.25	650	383

5.3 Installation Sequence for Wall-mounted AC Drives

Use these instructions to install the VACON[®]NX Wall-mounted AC Drive or VACON[®]NX Inverter FI4–FI8.

If the inverter is installed outside the enclosure, cabinet or device space, install a separate inverter cover in accordance with protection class IP21 requirements. There is no need to install the inverter cover if the inverter is installed in an enclosure, separate cabinet, or device space.

Procedure

- Select the mounting option:
 - Horizontal
If the drive is installed in a horizontal position, there is no protection against drops of water that fall vertically.
 - Vertical
 - Flange mounting
The AC drive can also be installed into the cabinet wall with a flange mounting option (through hole mounting). With the flange mounting, the protection rating of the power unit is IP54 (UL Type 12) and the protection rating of the control unit is IP21 (UL Type 1).
For details, see separate Flange Mounting Kit for FR4–FR6 Installation Manual or Flange Mounting Kit for FR7–FR9 Installation Manual.
- Check the dimensions of the AC drive, see [12.2.1 Dimensions for FI4–FI8](#), and [12.2.2 Dimensions for Flange Mounting, FI4–FI6](#) [12.2.3 Dimensions for Flange Mounting, FI7–FI8](#).
- Make sure that there is sufficiently free space around the AC drive for cooling, see [5.2.2 Cooling of FI4 to FI8](#). Some free space is also necessary for maintenance.
- Attach the AC drive with the screws and other components in the delivery.

6 Electrical Installation

6.1 Cable Connections

The power cables are connected to terminals **DC+** and **DC-** (R+/B+ and DC terminals when using an external charging circuit) and the motor cables to terminals **U**, **V**, and **W**.

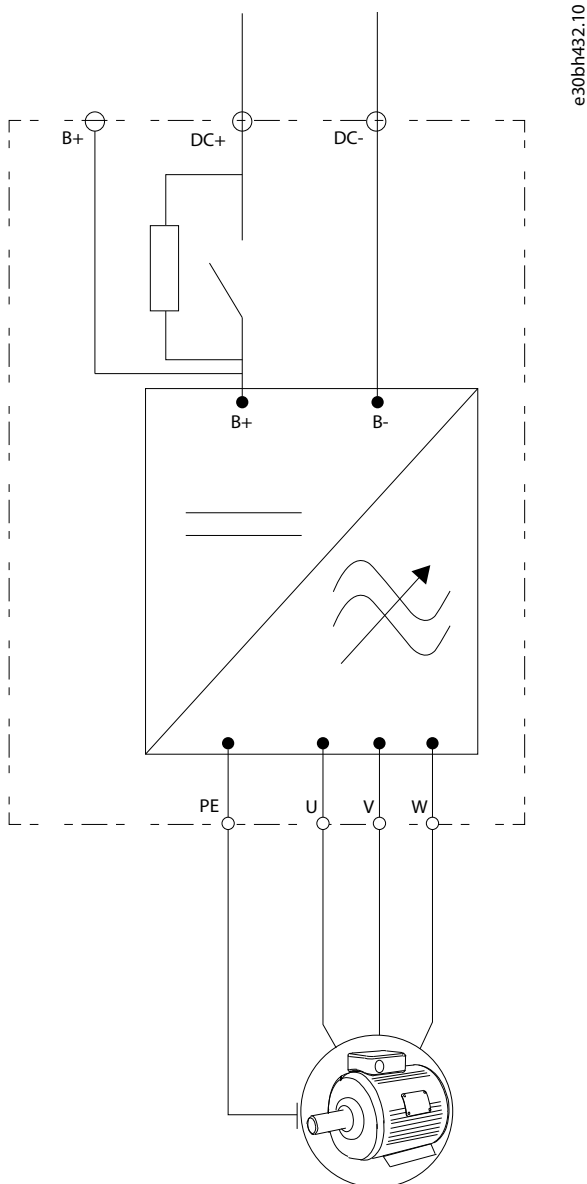

Illustration 13: Principal Connection Diagram

For EMC-compliant installation, see [6.3 EMC-compliant Installation](#).

6.1.1 General Cable Requirements

Use cables with a minimum heat resistance of +60 °C (140 °F). In the selection of the cables and the fuses, refer to the nominal output current of the drive. Find the nominal output current on the nameplate.

For information on how to make the cable installation to comply with the UL standards, see [6.1.2 UL Standards on Cabling](#).

If the motor temperature protection of the drive (see VACON[®] All in One Application Manual) is used as an overload protection, select the cable to agree with the protection.

These instructions are valid only for processes that have 1 motor and 1 cable connection from the AC drive to the motor. In other conditions, speak to the manufacturer to get more information.

6.1.2 UL Standards on Cabling

To comply with the UL (Underwriters Laboratories) regulations, use a UL-approved copper wire with a minimum heat resistance of 60 °C or 75 °C (140 °F or 167 °F).

Use Class 1 wire only.

The integral solid-state short-circuit protection does not give a branch circuit protection. To get the branch circuit protection, obey the National Electric Code and any additional local codes. Only fuses give the branch circuit protection.

For the tightening torques of the terminals, see [12.6 Tightening Torques of the Terminals](#).

6.1.3 Cable Selection and Dimensioning

Find the typical sizes and types of cables used with the inverter in the tables in [12.3 Cable and Fuse Sizes](#). In the selection of cables, refer to local regulations, cable installation conditions, and cable specification.

The dimensions of the cables must comply with the requirements of the standard IEC60364-5-52.

- The maximum ambient temperature is +30 °C.
- The maximum temperature of the cable surface is +70 °C.
- Use only motor cables with a concentric copper shield.
- The maximum number of parallel cables is 9.

When using parallel cables, make sure to obey the requirements of the cable cross-sections.

For important information on the requirements of the grounding conductor, see [6.2 Grounding](#).

For the correction factors for each temperature, see the standard IEC60364-5-52.

6.1.4 Cable Selection and Dimensioning, North America

Find the typical sizes and types of cables used with the AC drive in the tables in [12.3 Cable and Fuse Sizes](#). In the selection of cables, refer to local regulations, cable installation conditions, and cable specification.

The dimensions of the cables must comply with the requirements of the National Electric Code (NEC) and the Canadian Electric Code (CEC).

- The maximum ambient temperature is +86 °F.
- The maximum temperature of the cable surface is +158 °F.
- Use only motor cables with a concentric copper shield.
- The maximum number of parallel cables is 9.

When using parallel cables, make sure to obey the requirements of the cross-sectional area and the maximum number of cables.

For important information on the requirements of the grounding conductor, see the NEC and CEC.

For the correction factors for each temperature, see the instructions of NEC and CEC.

6.1.5 Fuse Selection

Find the recommended fuses in tables in [12.3 Cable and Fuse Sizes](#).

Information about the fuses:

- aR fuses protect the cables of the device against short circuits.
- gR fuses are designed to protect the device against both overcurrent and short circuits.
- gG fuses are used to protect cables against overcurrent and short circuits.

6.2 Grounding

Ground the AC drive in accordance with applicable standards and directives.

⚠ CAUTION ⚠

DAMAGE TO THE AC DRIVE FROM INSUFFICIENT GROUNDING

Not using a grounding conductor can damage the drive.

- Make sure that the AC drive is always with a grounding conductor that is connected to the grounding terminal that is identified with the PE symbol.

⚠ W A R N I N G ⚠

LEAKAGE CURRENT HAZARD

Leakage currents exceed 3.5 mA. Failure to ground the drive properly can result in death or serious injury.

- Ensure the correct grounding of the equipment by a certified electrical installer.

The standard EN 61800-5-1 tells that 1 or more of these conditions for the protective circuit must be true.

The connection must be fixed.

- The protective earthing conductor must have a cross-sectional area of minimum 10 mm² Cu or 16 mm² Al. OR
- There must be an automatic disconnection of the mains, if the protective earthing conductor breaks. OR
- There must be a terminal for a second protective earthing conductor in the same cross-sectional area as the first protective earthing conductor.

Cross-sectional area of the phase conductors (S) [mm ²]	The minimum cross-sectional area of the protective earthing conductor in question [mm ²]
S ≤ 16	S
16 < S ≤ 35	16
35 < S	S/2

The values of the table are valid only if the protective earthing conductor is made of the same metal as the phase conductors. If this is not so, the cross-sectional area of the protective earthing conductor must be determined in a manner that produces a conductance equivalent to that which results from the application of this table.

The cross-sectional area of each protective earthing conductor that is not a part of the mains cable or the cable enclosure, must be a minimum of:

- 2.5 mm² if there is mechanical protection, and
- 4 mm² if there is not mechanical protection. With cord-connected equipment, make sure that the protective earthing conductor in the cord is the last conductor to be interrupted, if the strain-relief mechanism breaks.

Obey the local regulations on the minimum size of the protective earthing conductor.

N O T I C E

MALFUNCTION OF FAULT CURRENT PROTECTIVE SWITCHES

Because there are high capacitive currents in the AC drive, it is possible that the fault current protective switches do not operate correctly.

N O T I C E

VOLTAGE WITHSTAND TESTS

Doing voltage withstand tests can damage the drive.

- Do not do voltage withstand tests on the AC drive. The manufacturer has already done the tests.

⚠ W A R N I N G ⚠

SHOCK HAZARD FROM PE CONDUCTOR

The drive can cause a DC current in the PE conductor. Failure to use a residual current-operated protective (RCD) device Type B or a residual current-operated monitoring (RCM) device can lead to the RCD not providing the intended protection and therefore can result in death or serious injury.

- Use a type B RCD or RCM device on the mains side of the drive.

6.3 EMC-compliant Installation

To comply with the EMC levels, use a grommet when installing the motor cable at the two ends. For the EMC level C4, it is necessary to have a 360° grounding of the shield with grommets in the motor end.

Table 9: Recommendations for Cables

Cable type	Category C4 (Level T)
Supply cable	Power cable intended for fixed installation and the specific DC voltage. Shielded cable not required. (NKCABLES/MCMK or similar recommended)
Motor cable	Power cable equipped with concentric protection wire and intended for the specific mains voltage. (NKCABLES/MCMK or similar recommended).
Control cable	Shielded cable equipped with compact low-impedance shield (NKCABLES/jamak, SAB/ÖZCuY-O or similar).

For the definitions of EMC protection levels, see IEC/EN 61800-3 + A1.

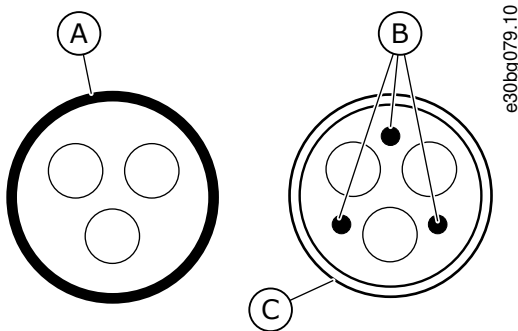

Illustration 14: Cables with PE Conductors

A	The PE conductor and the shield	C	The shield
B	The PE conductors		

In all the enclosure sizes, to comply with the EMC standards, use the default values of the switching frequencies.

If installing a safety switch, make sure that the EMC protection continues from the start of the cables until their ends.

The drive must obey the standard IEC 61000-3-12. To obey it, the short circuit power S_{SC} must be a minimum of $120 R_{SCE}$ at the interface point between mains and the public mains. Make sure to connect the drive and the motor to mains with a short circuit power S_{SC} that is a minimum of $120 R_{SCE}$. If necessary, contact the mains operator.

6.4 Get Access and Locate the Terminals

6.4.1 Get Access and Locate the Terminals for FR4/FI4

Follow these instructions to open the AC drive for installing the cables.

Procedure

1. Open the cover of the AC drive.

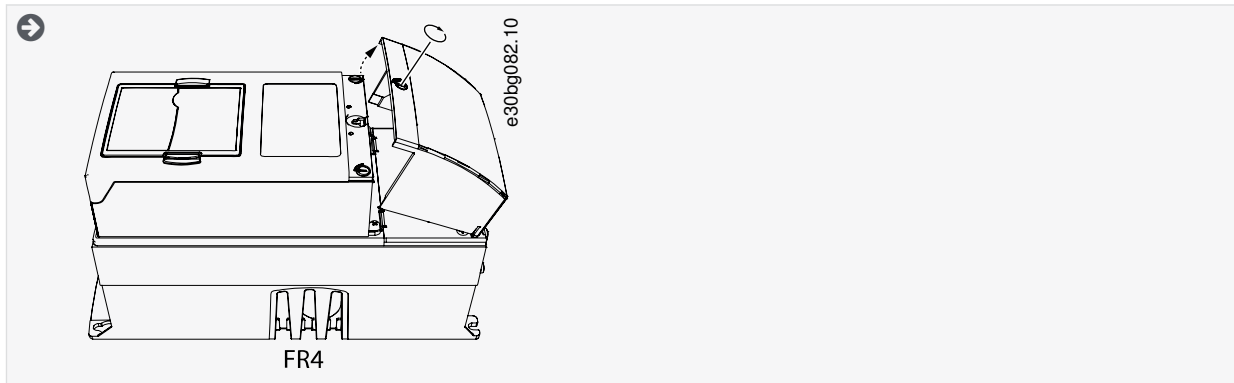

2. Remove the screws of the cable cover. Remove the cable cover. Do not open the cover of the power unit.

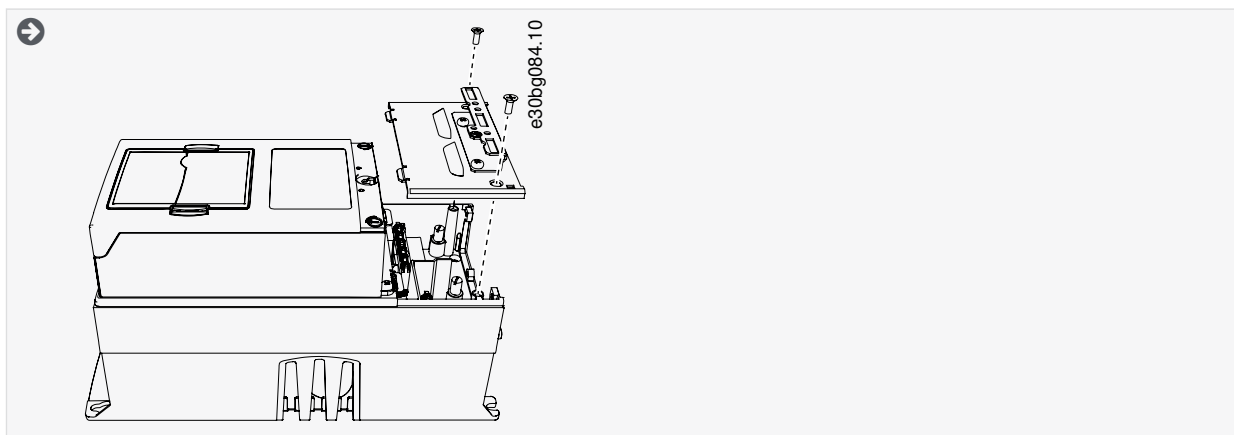

3. Locate the terminals.

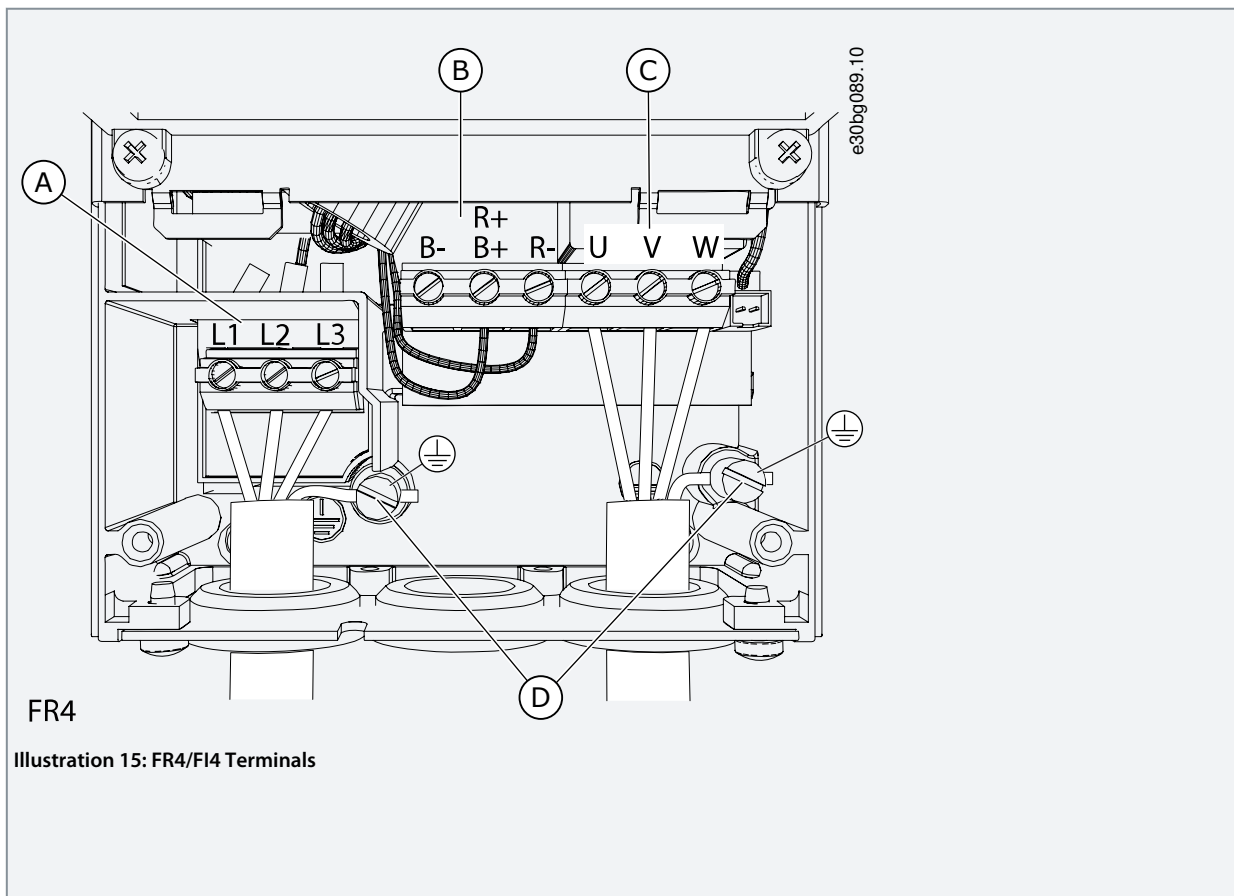

Illustration 15: FR4/FI4 Terminals

A	Mains terminals	C	Motor terminals
B	Brake resistor terminals	D	Grounding terminals

6.4.2 Get Access and Locate the Terminals for FR6/FI6

Follow these instructions to open the AC drive for installing the cables.

Procedure

1. Open the cover of the AC drive.

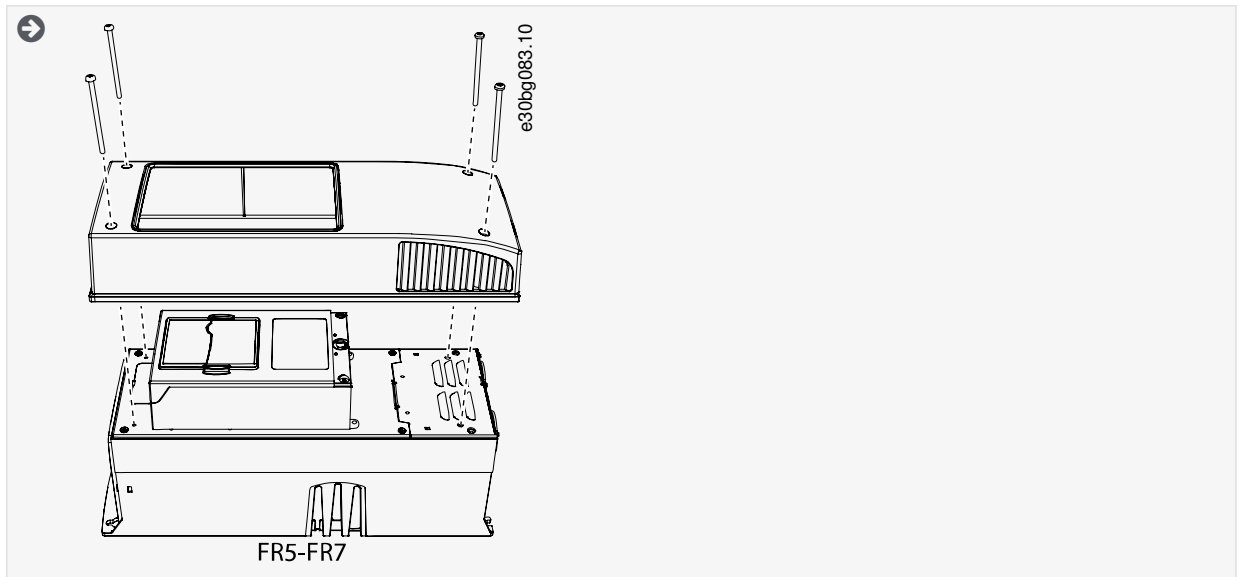

2. Remove the screws of the cable cover. Remove the cable cover. Do not open the cover of the power unit.

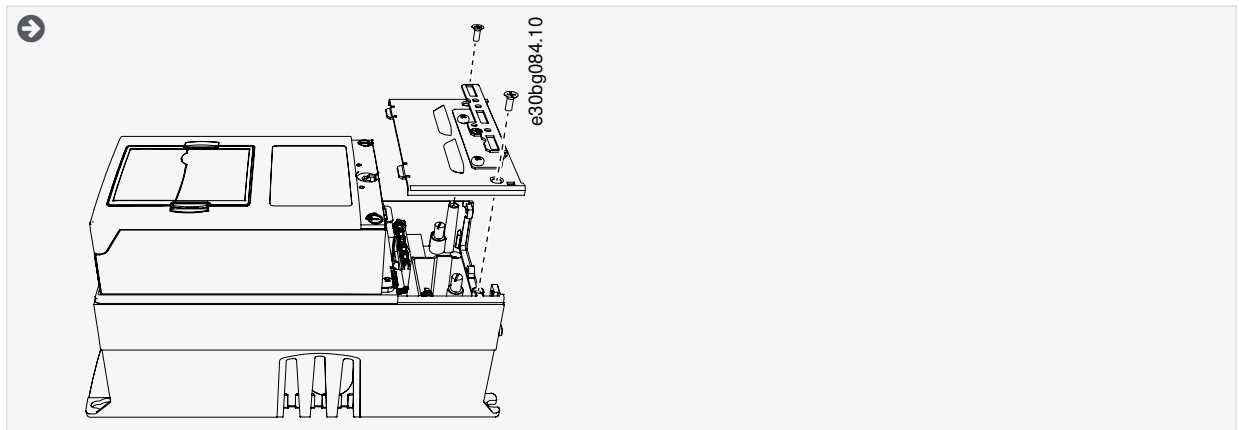

3. Locate the terminals.

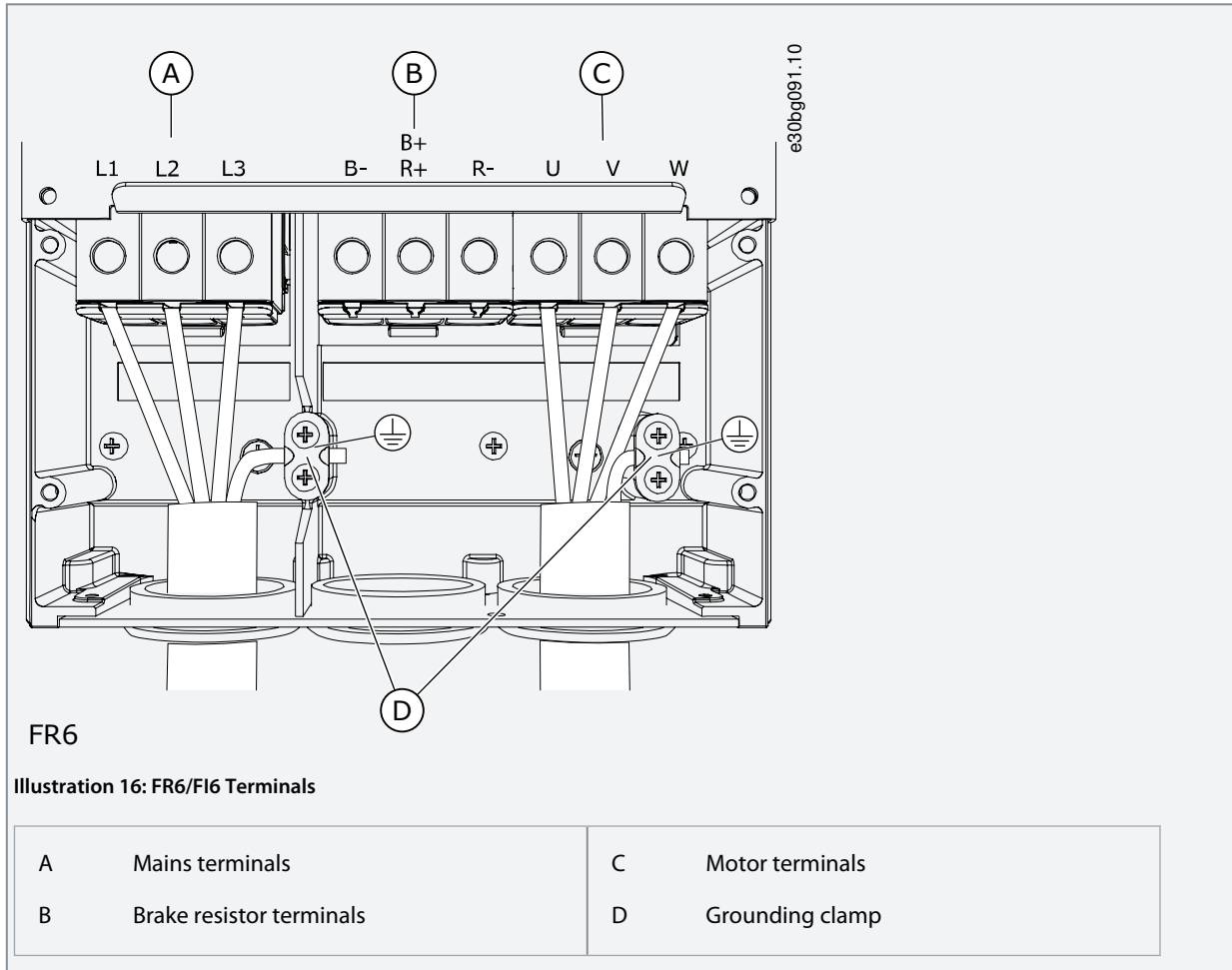

6.4.3 Get Access and Locate the Terminals for FR7/FI7

Follow these instructions to open the AC drive for installing the cables.

Procedure

1. Open the cover of the AC drive.

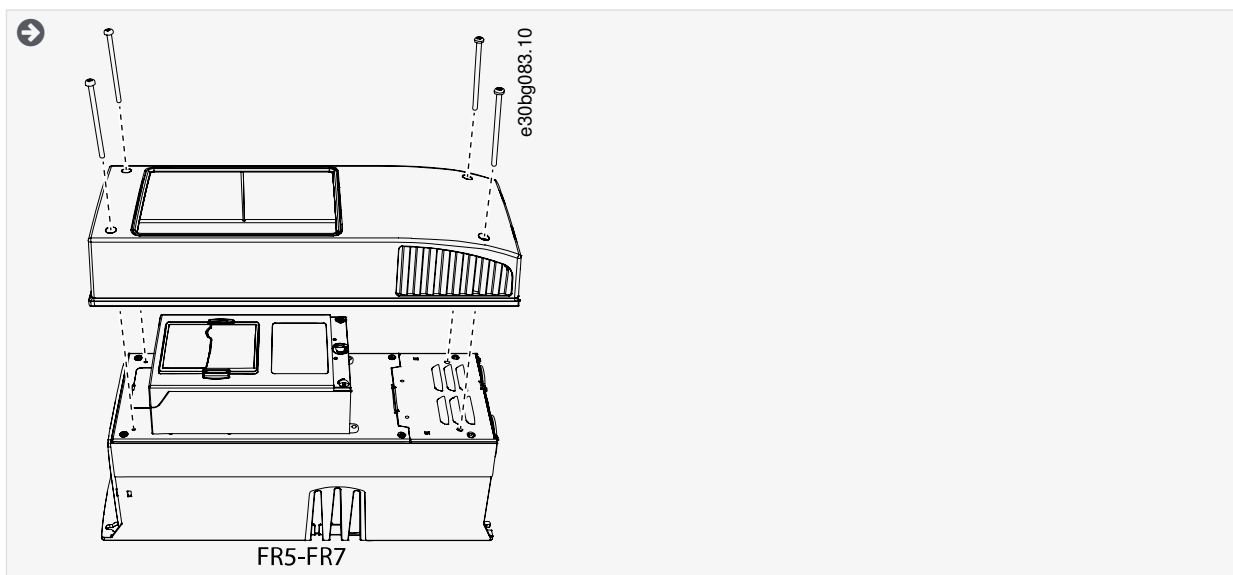

- Remove the screws of the cable cover. Remove the cable cover. Do not open the cover of the power unit.

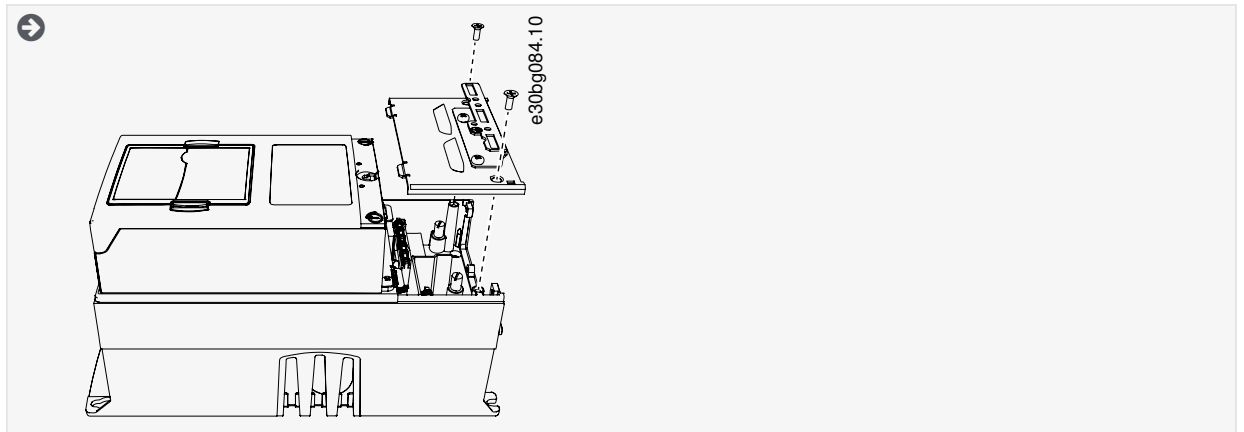

- Locate the terminals.

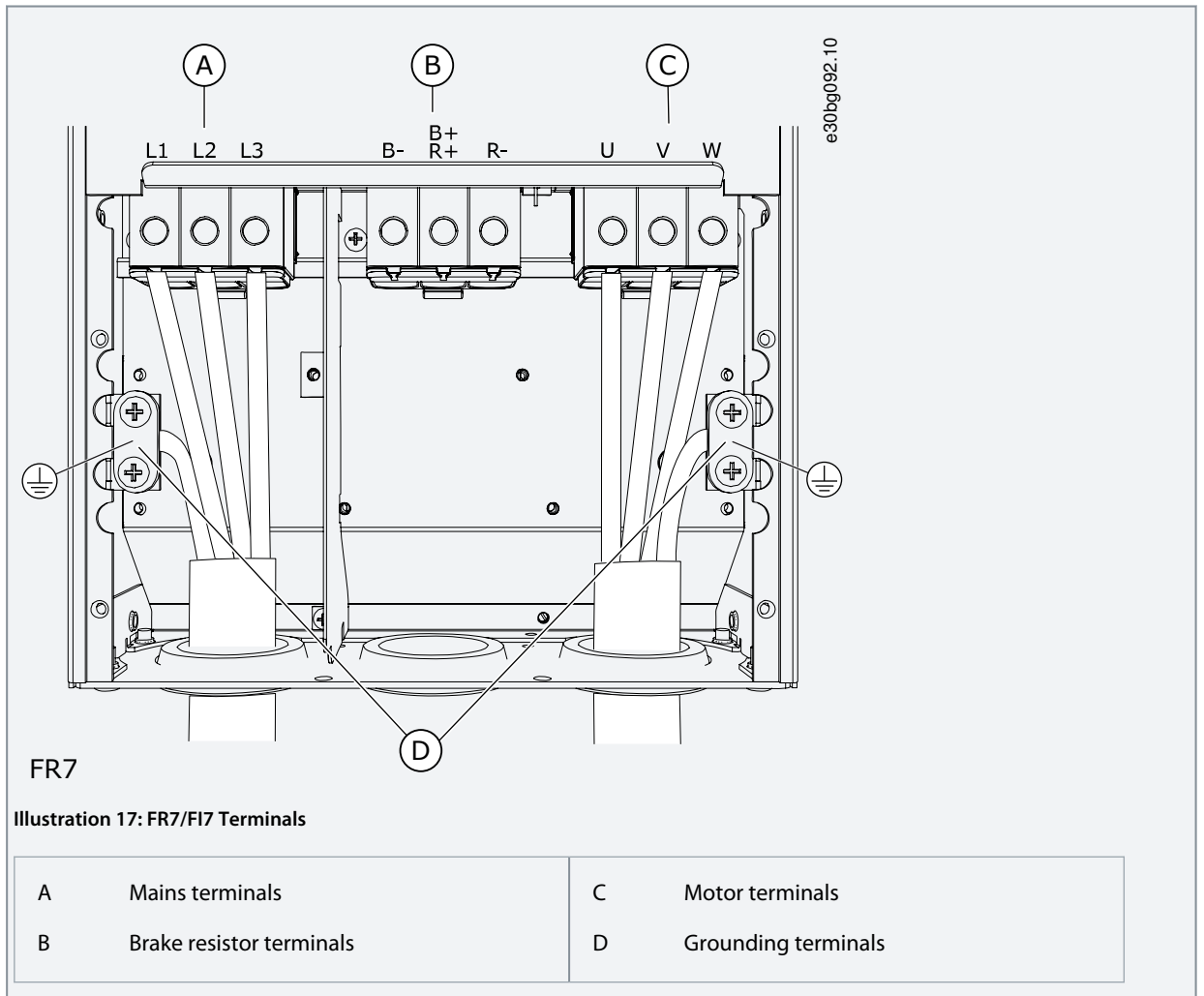

6.4.4 Get Access and Locate the Terminals for FR8/FI8

Follow these instructions to open the AC drive for installing the cables.

Procedure

1. Open the cover of the AC drive.

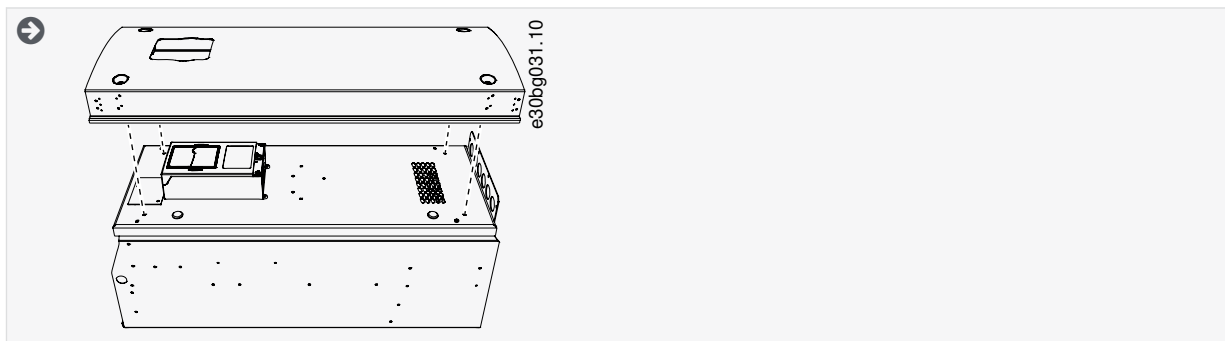

2. Open the power unit cover.

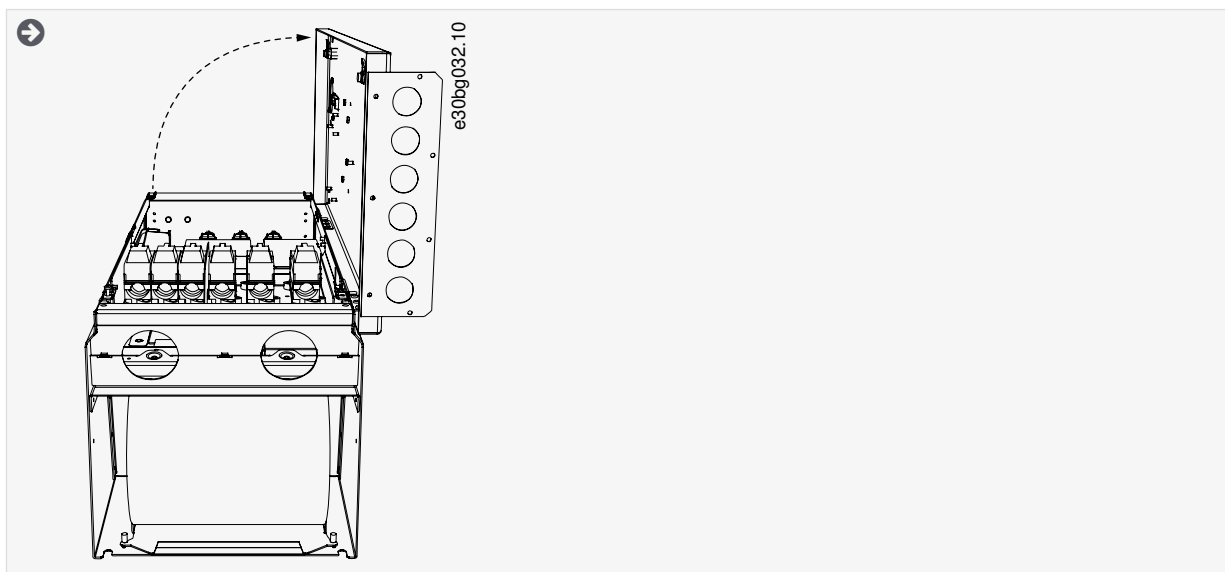

3. Find the DC terminals and Brake resistor terminals on top of the AC drive.

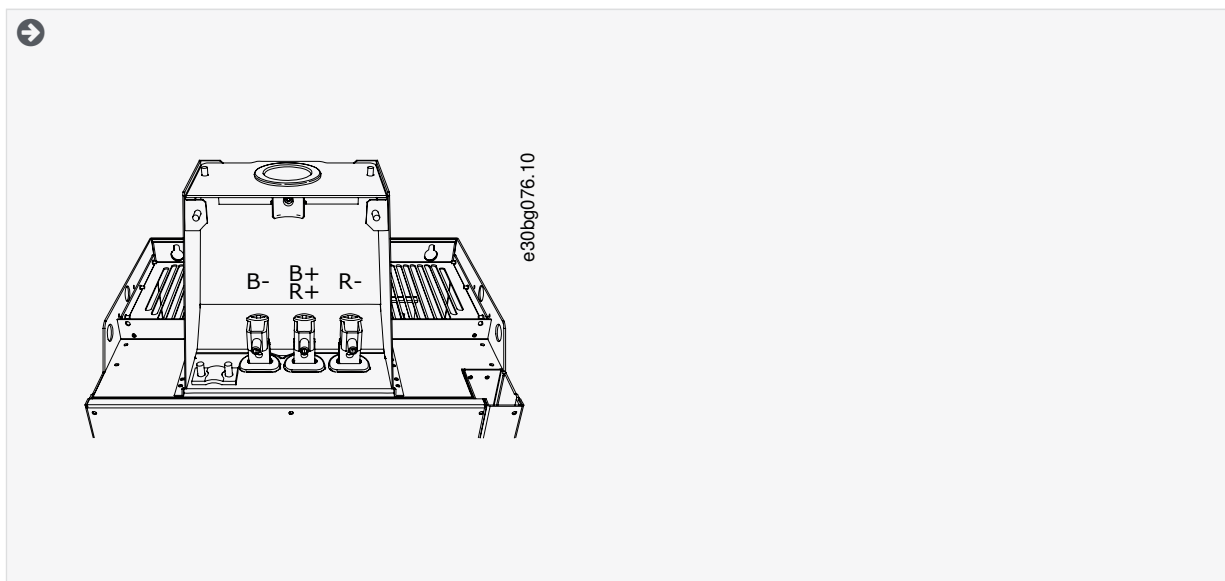

4. Locate the terminals.

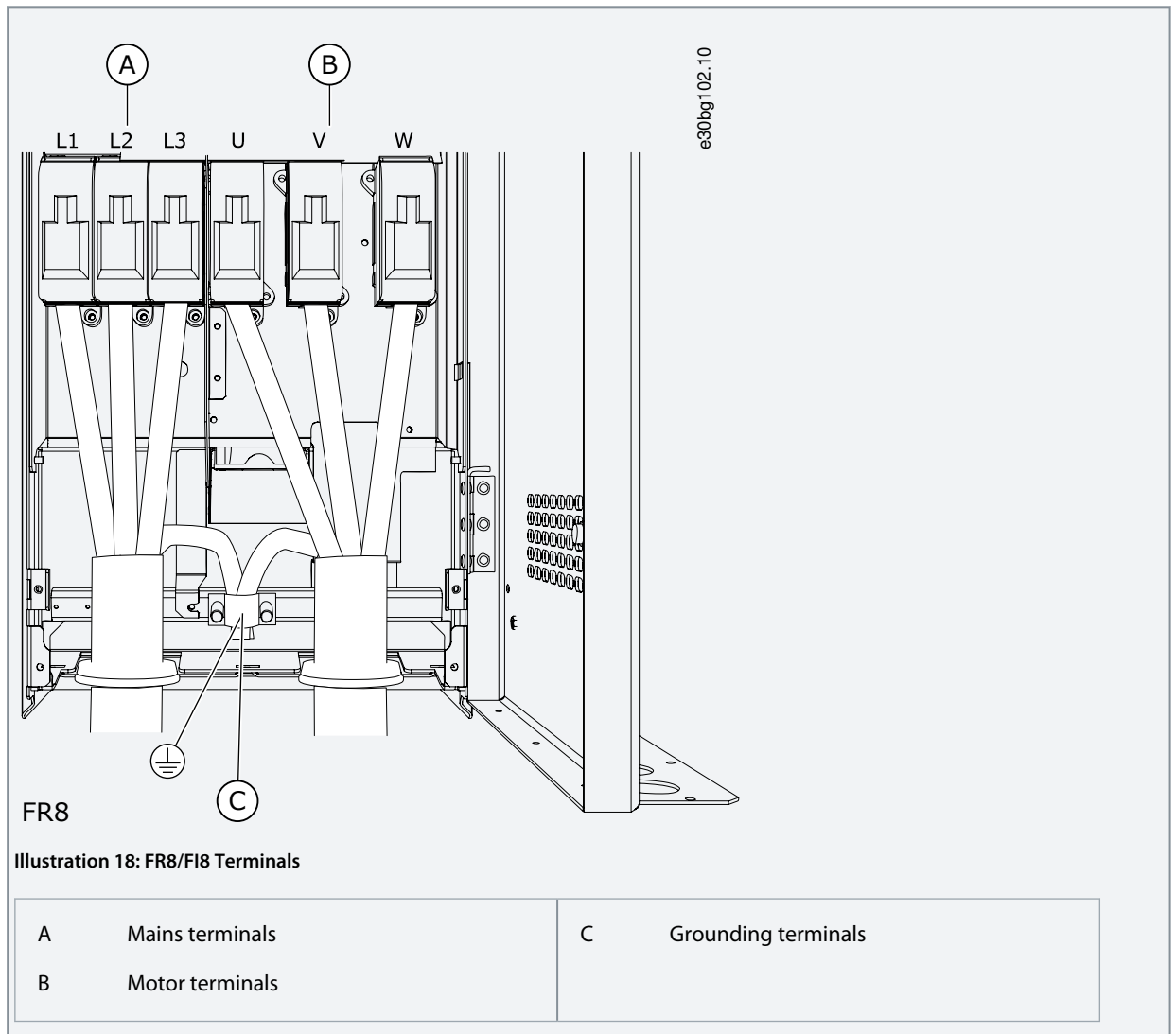

6.5 Installing the Cables

Use these instructions to find the installation instructions of the correct enclosure size.

Procedure

1. Check the requirements related to lengths, distances, and positioning of the cables according to instructions in [6.5.1 Additional Instructions for Cable Installation](#).
2. Follow the installation instructions of the correct enclosure size. To check the enclosure size of the AC drive, see [3.7 Enclosure Sizes](#).

- [6.5.2 Installing the Cables, FR4–FR6/FI4–FI6](#)
- [6.5.3 Installing the Cables, FR7/FI7](#)
- [6.5.4 Installing the Cables, FR8/FI8](#)

6.5.1 Additional Instructions for Cable Installation

- Before starting, make sure that none of the components of the AC drive is live. Read carefully the warnings in Safety section.
- Make sure that the motor cables are sufficiently far from other cables.
- The motor cables must go across other cables at an angle of 90°.
- If it is possible, do not put the motor cables in long parallel lines with other cables.
- If the motor cables are in parallel with other cables, obey the minimum distances (see [Table 10](#)).

- The distances are also valid between the motor cables and the signal cables of other systems.
- The maximum lengths of shielded motor cables are 300 m (984 ft) (AC drives with power greater than 1.5 kW or 2 hp), and 100 m (328 ft) (AC drives with power from 0.75 kW to 1.5 kW or 1–2 hp). If the used motor cables are longer, speak to the factory to get more information.
Each parallel cable adds to the total length.

NOTICE

If long motor cables are used (maximum 100 m or 328 ft) together with small drives (≤ 1.5 kW or ≤ 2.01 hp), the capacitive current in the motor cable can increase the measured motor current compared to the actual motor current. Consider it when setting up the motor stall protection functions.

- If the cable insulation checks are necessary, see [9.3 Measuring the Cable and Motor Insulation](#).

Table 10: Minimum Distances between Cables

The distance between cables [m]	The length of the shielded cable [m]	The distance between cables [ft]	The length of the shielded cable [ft]
0.3	≤ 50	1.0	≤ 164.0
1.0	≤ 200	3.3	≤ 656.1

6.5.2 Installing the Cables, FR4–FR6/FI4–FI6

Follow these instructions to install the cables and cable accessories.

For information on how to comply with the UL regulations in cable installation, see [6.1.2 UL Standards on Cabling](#).

If it is necessary to connect an external brake resistor, see VACON[®] Brake Resistor Manual. See also [8.7.8.2 Setting the Internal Brake Resistor Connection](#).

Make sure that the delivery contains all necessary components. For the installation, the contents of the accessories bag is needed, see [4.1 Checking the Delivery](#).

Open the covers according to instructions in [6.4.1 Get Access and Locate the Terminals for FR4/FI4](#), or [6.4.2 Get Access and Locate the Terminals for FR6/FI6](#).

Procedure

1. Strip the DC supply cable, the mains cable, and the brake resistor cable. See [12.4 Cable Stripping Lengths](#).
2. Cut the grommets open to move the cables through them. Use the grommets delivered in the accessories bag.

Do not cut the grommet openings wider than what is necessary for the used cables.

If the grommets fold in when putting the cable, pull the cable back to make the grommets straight.

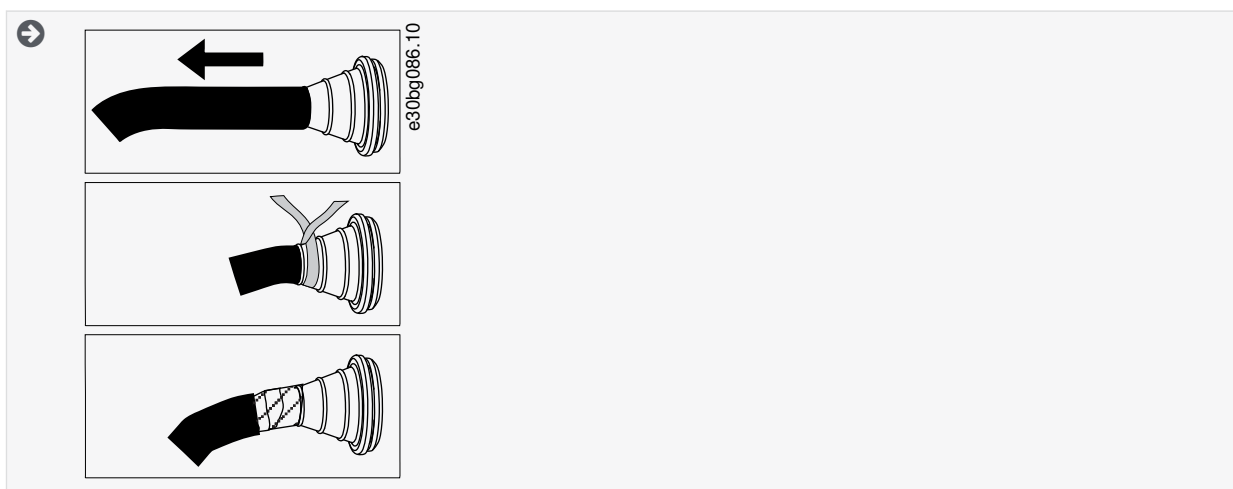

- To achieve EMC class C1 and C2, use EMC cable gland as an alternative to the grommet.

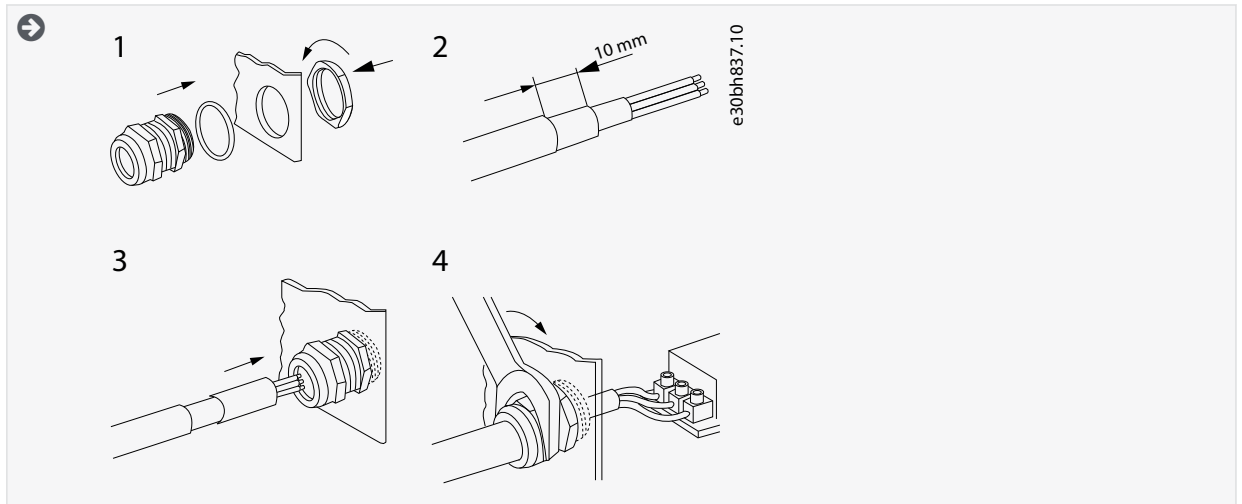

- Put the cables - the DC supply cable, the motor cable, and the optional brake cable - in the openings of the cable entry plate. Use the cable entry plate delivered in the accessories bag.

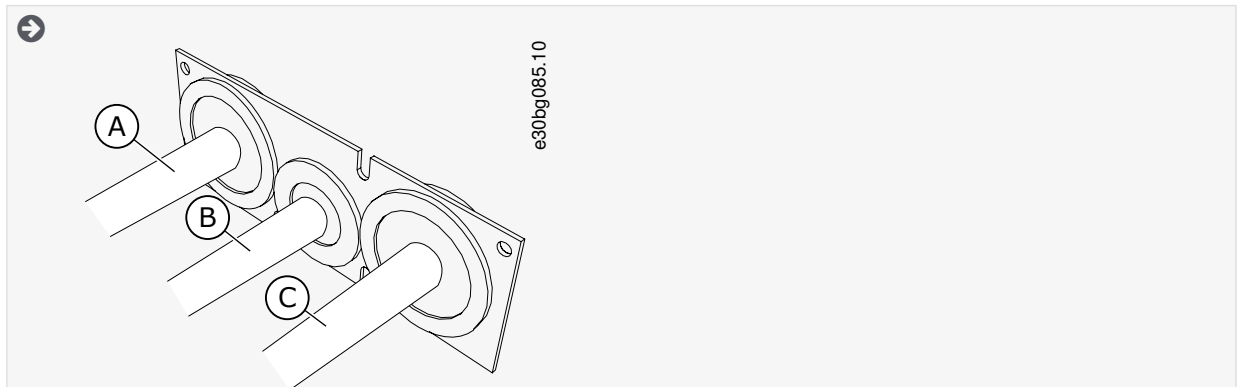
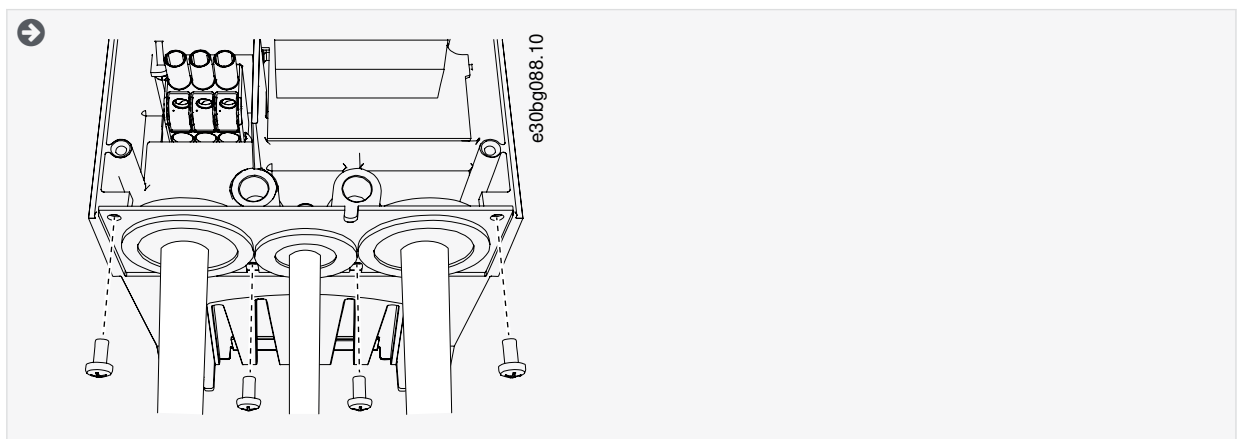

Illustration 19: Cables through the Cable Entry Plate

A	The DC supply cable	C	The motor cable
B	The brake cable		

- Put the cable entry plate with the cables into the groove on the frame of the drive. To attach the cable entry plate, use the M4x10 screws delivered in the accessories bag.



6. Connect the cables. See the correct tightening torques in [12.6 Tightening Torques of the Terminals](#).

- Connect the phase conductors of the DC supply cable and of the motor cable, and the conductors of the brake resistor cable into the correct terminals.
- FR4/FI4, FR5: Attach the grounding conductor of each cable with a grounding terminal. Use the grounding terminals delivered in the accessories bag.
- FR6/FI6: Attach the grounding conductor of each cable with a grounding clamp for grounding conductor. Use the grounding clamps and the screws delivered in the accessories bag.

7. Make sure to connect the grounding conductor to the motor and the terminals that are identified with the grounding symbol.

- For FR4/FI4 and FR5: Two protective conductors are necessary to comply with the requirements of the standard IEC/EN 61800-5-1. See [6.2 Grounding](#).
- If a double grounding is necessary, use the grounding terminal below the drive. Use an M5 screw and tighten it to 2.0 Nm or 17.7 lb-in.

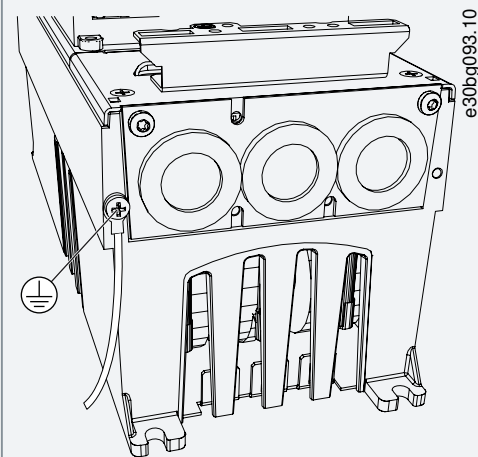

8. Attach the cable cover [12.5 Tightening Torques for Cover Screws](#).
9. Attach the grounding clamps for control cable with 3 pieces of M4x16 screws delivered in the accessories bag. Use these clamps to ground the control cables. Connect the control cables.

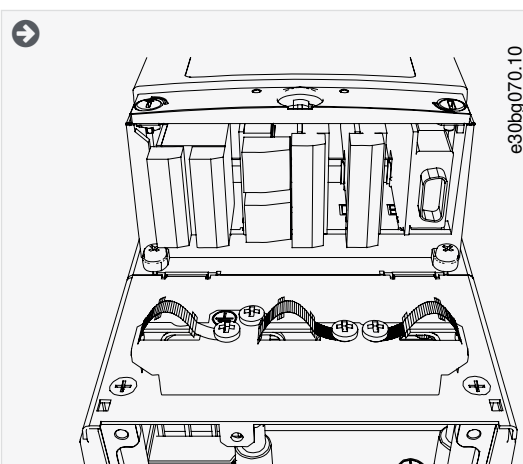

Illustration 20: FR4-FR6/FI4-FI6

10. Attach the cover of the drive. For the tightening torques of the screws, see [12.5 Tightening Torques for Cover Screws](#). Make sure that the control cables or the cables of the AC drive are not caught between the frame and the cable cover.

6.5.3 Installing the Cables, FR7/FI7

Follow these instructions to install the cables and cable accessories.

For information on how to comply with the UL regulations in cable installation, see [6.1.2 UL Standards on Cabling](#).

If it is necessary to connect an external brake resistor, see VACON[®] Brake Resistor Manual. See also [8.7.8.2 Setting the Internal Brake Resistor Connection](#).

Make sure that the delivery contains all necessary components. For the installation, the contents of the accessories bag is needed, see [4.1 Checking the Delivery](#).

Open the covers according to instructions in [6.4.3 Get Access and Locate the Terminals for FR7/FI7](#).

Procedure

1. Strip the motor cable, the mains cable, and the brake resistor cable. See [12.4 Cable Stripping Lengths](#).
2. Cut the grommets open to move the cables through them. Use the grommets delivered in the accessories bag.

Do not cut the grommet openings wider than what is necessary for the used cables.

If the grommets fold in when putting the cable, pull the cable back to make the grommets straight.



3. To achieve EMC class C2, use EMC cable gland as an alternative to the grommet.

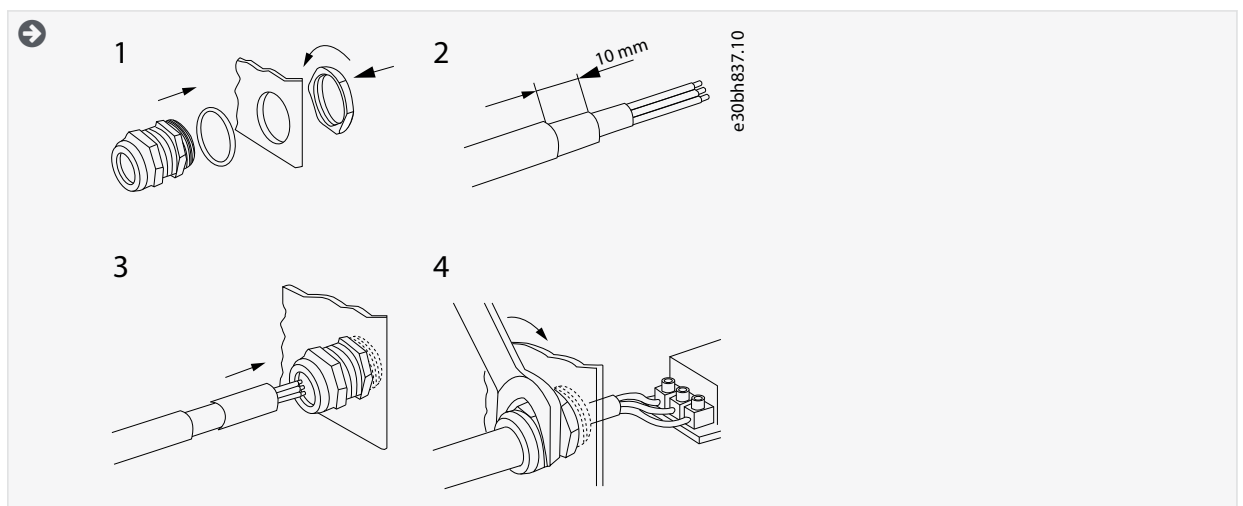

- Put the cables - the DC supply cable, the motor cable, and the optional brake cable - in the openings of the cable entry plate. Use the cable entry plate delivered in the accessories bag.

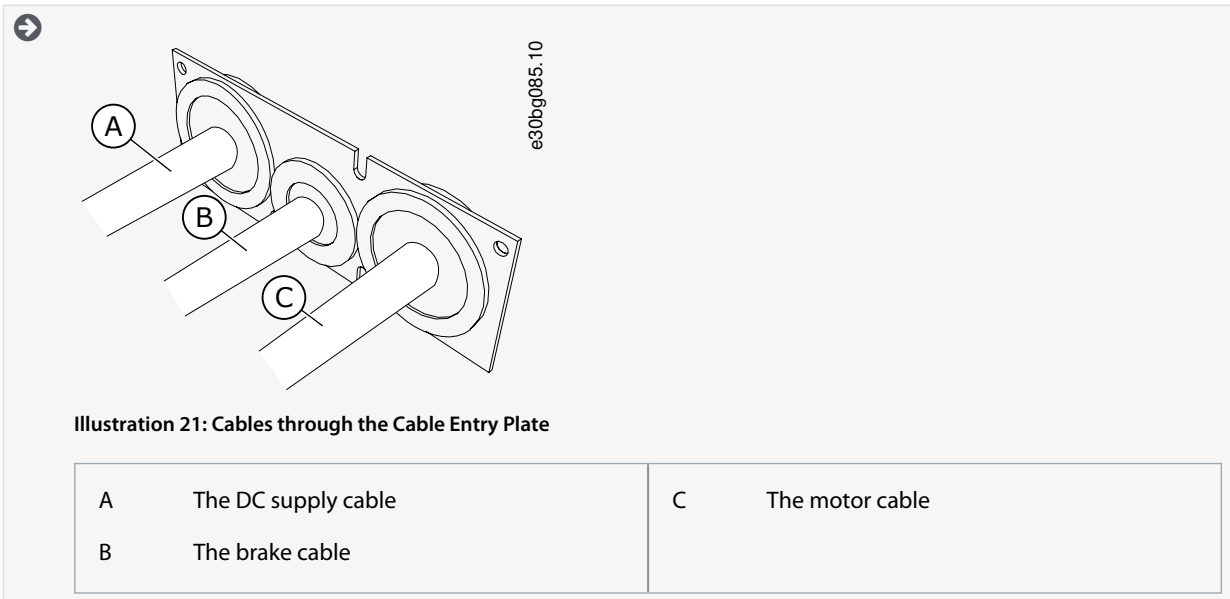

- Put the cable entry plate with the cables into the groove on the frame of the drive. To attach the cable entry plate, use the M4x10 screws delivered in the accessories bag.

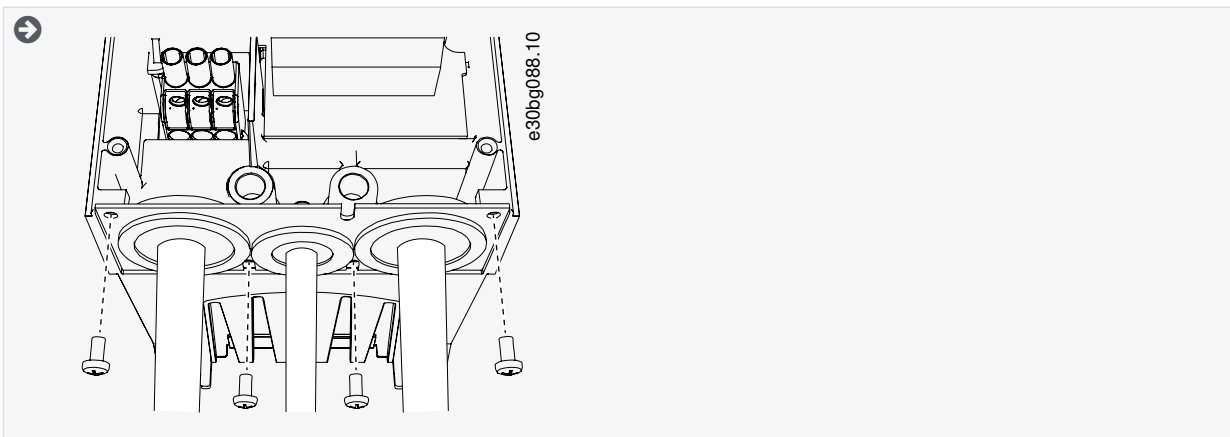

- Connect the cables. See the correct tightening torques in [12.6 Tightening Torques of the Terminals](#).

- Connect the phase conductors of the DC supply cable and of the motor cable, and the conductors of the brake resistor cable into the correct terminals.
- Attach the grounding conductor of each cable with a grounding clamp.

- Make sure to connect the grounding conductor to the motor and the terminals that are identified with the grounding symbol.

- If a double grounding is necessary, use the grounding terminal below the drive. Use an M5 screw and tighten it to 2.0 Nm or 17.7 lb-in.

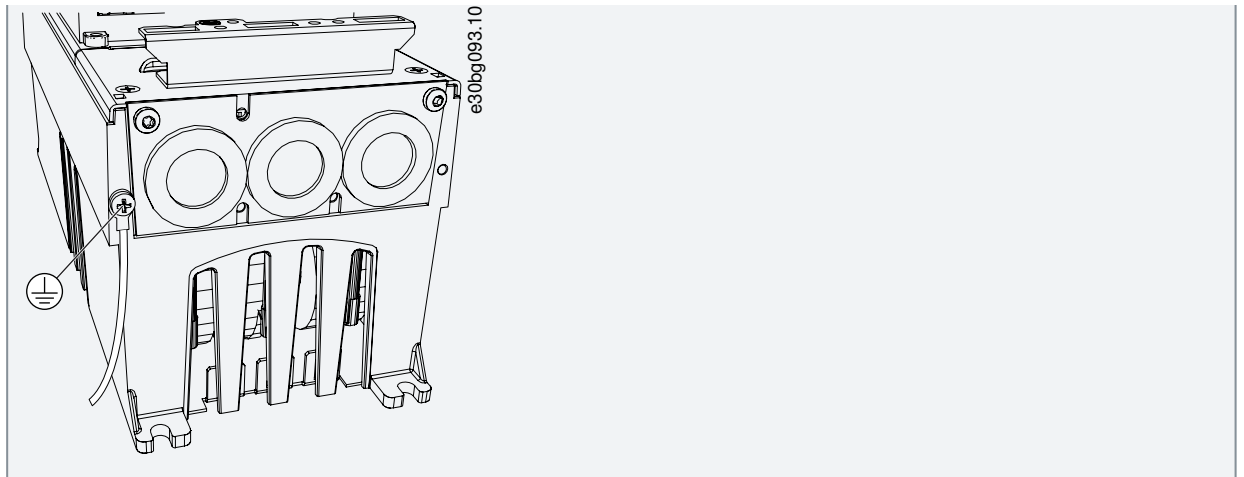

8. Attach the cable cover [12.5 Tightening Torques for Cover Screws](#).
9. Attach the grounding clamps for control cable with 3 pieces of M4x16 screws delivered in the accessories bag. Use these clamps to ground the control cables. Connect the control cables.

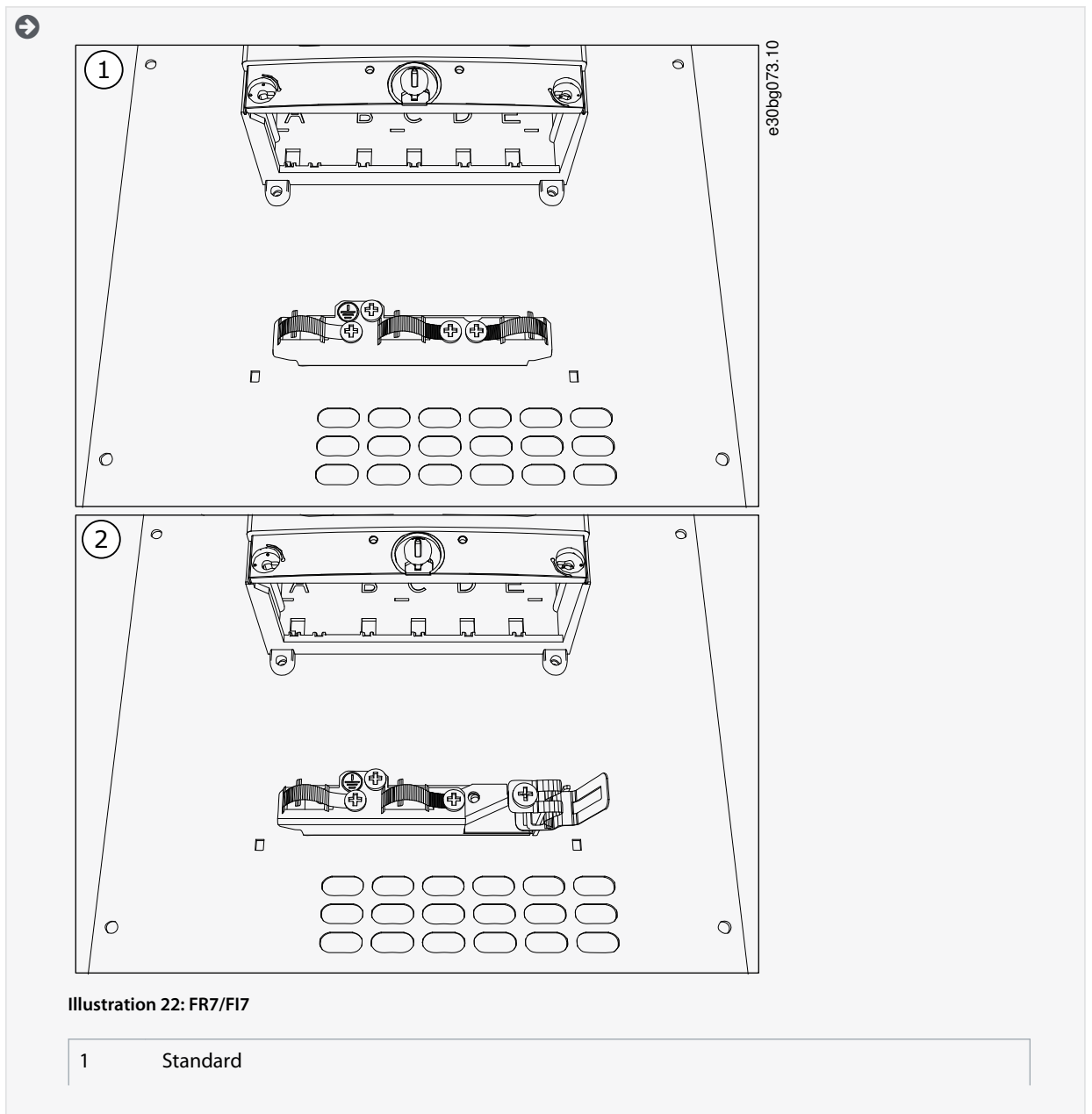

2	PROFIBUS
---	----------

- Attach the cover of the drive. For the tightening torques of the screws, see [12.5 Tightening Torques for Cover Screws](#). Make sure that the control cables or the cables of the AC drive are not caught between the frame and the cable cover.

6.5.4 Installing the Cables, FR8/FI8

Follow these instructions to install the cables and cable accessories.

For information on how to comply with the UL regulations in cable installations, see [6.1.2 UL Standards on Cabling](#).

If it is necessary to connect an external brake resistor, see VACON® Brake Resistor Manual. See also [8.7.8.2 Setting the Internal Brake Resistor Connection](#).

Make sure that the delivery contains all necessary components. For the installation, the contents of the accessories bag is needed, see [4.1 Checking the Delivery](#).

Open the covers according to instructions in [6.4.4 Get Access and Locate the Terminals for FR8/FI8](#).

Procedure

- Strip the motor cable, the DC supply cable, and the brake resistor cable. See [12.4 Cable Stripping Lengths](#).
- To move the cables through the grommets, cut them open. Use the grommets delivered in the accessories bag.

Do not cut the grommet openings wider than what is necessary for the used cables.

If the grommets fold in when putting the cable, pull the cable back to make the grommets straight.

Cable gland can be used if preferred.

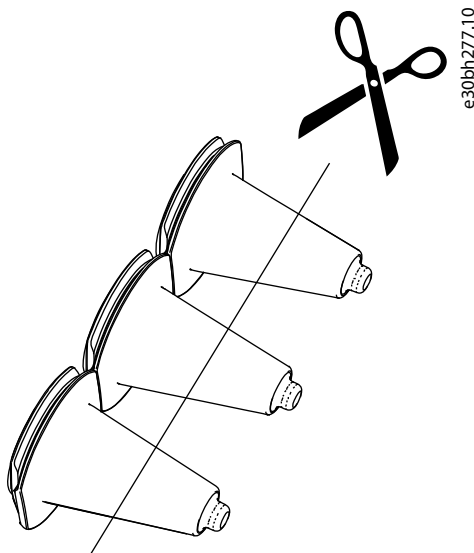
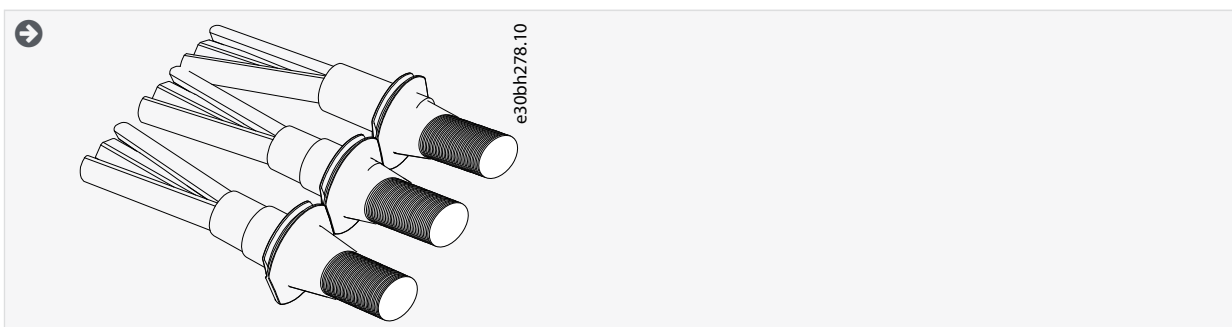
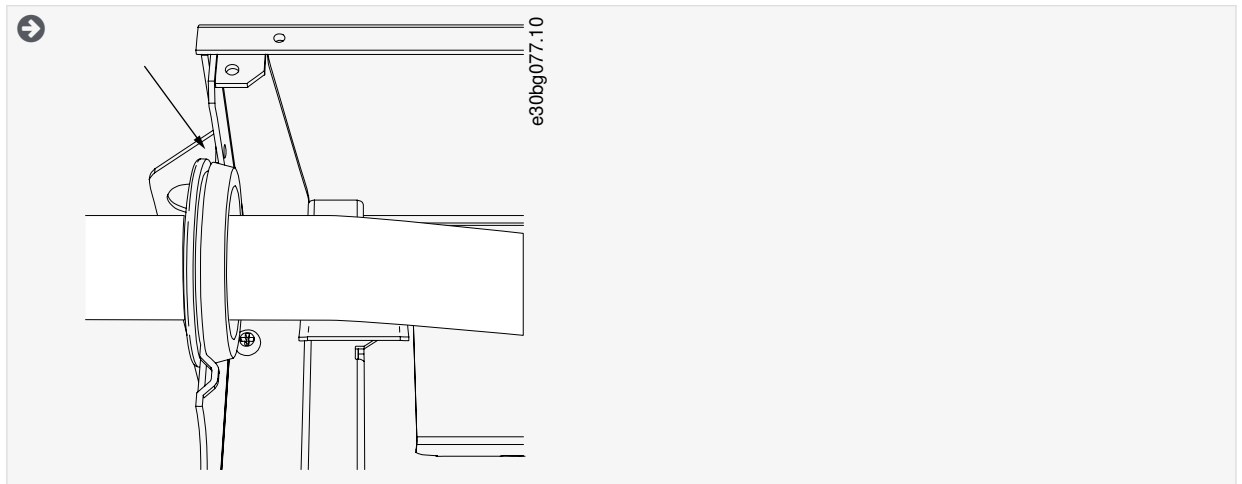

Illustration 23: Cutting the Grommet in IP54



- Attach the grommet and the cable until the frame of the drive goes into the groove of the grommet.

- With the protection rating IP54 (UL Type 12), the connection between the grommet and the cable must be tight. Pull the first bit of the cable out of the grommet until it stays straight.
- If it is not possible, make the connection tight with some insulation tape or a cable tie.



4. Connect the cables. See the correct tightening torques in [12.6 Tightening Torques of the Terminals](#).

- Connect the phase conductors of the DC supply cable and of the motor cable into the correct terminals. If a brake resistor cable is used, connect its conductors into the correct terminals.
- Attach the grounding conductor of each cable to a grounding terminal with a grounding clamp for grounding conductor.

5. To make a 360° connection with the grounding clamp for cable shield, expose the shield of motor cables.

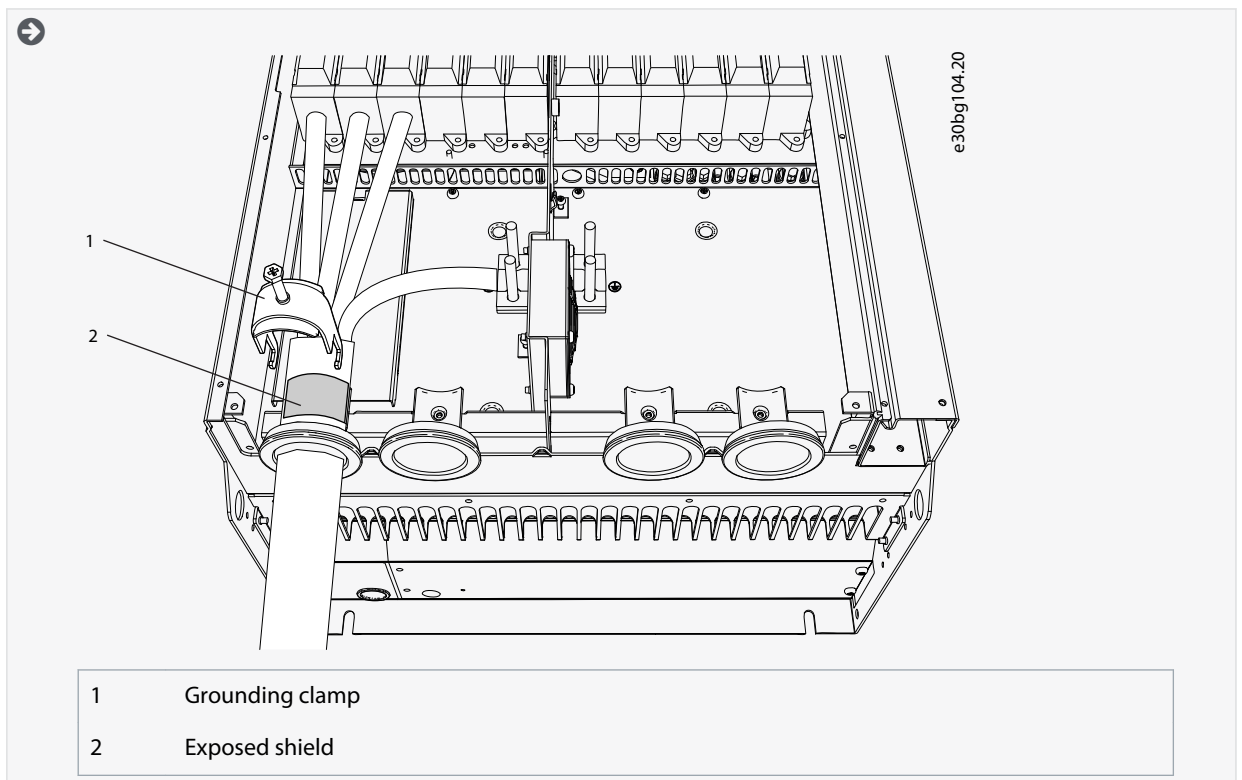

6. Attach the cable entry plate, and then the cable cover. For the tightening torques of the screws, see [12.5 Tightening Torques for Cover Screws](#). Make sure that the control cables or the cables of the AC drive are not caught between the frame and the cable cover.

- Additional tightening torques:
- motor cable entry plate: 2.4 Nm
 - control cable entry plate: 0.8 Nm
 - DC cover: 2.4 Nm

- Attach the grounding clamps for control cable on the grounding level with M4x16 screws. Use the clamps delivered in the accessories bag. Use the clamps to ground the control cables. Connect the control cables.

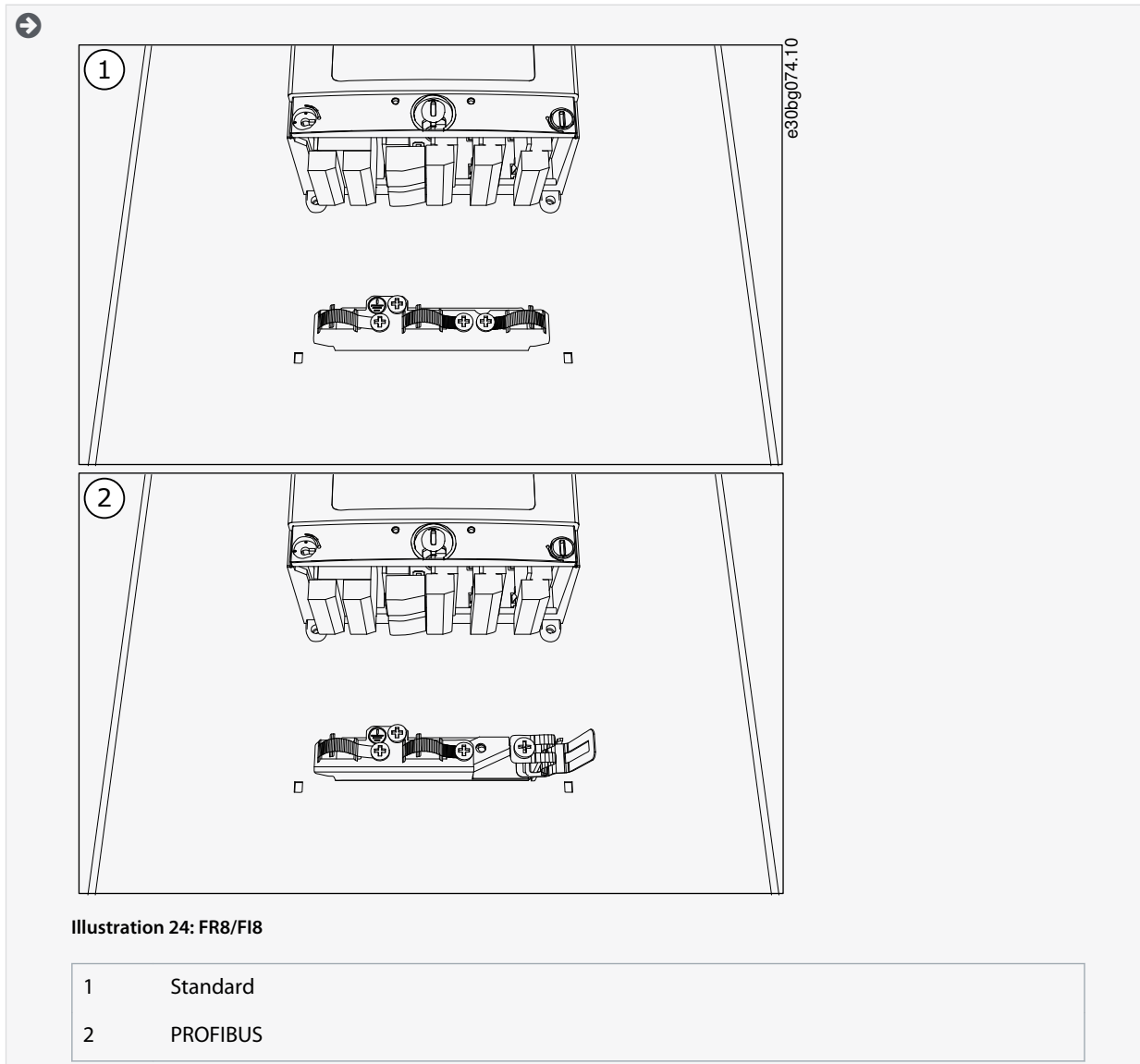

- Attach the cover of the drive. For the tightening torques of the screws, see [12.5 Tightening Torques for Cover Screws](#).

7 Control Unit

7.1 Control Unit Components

The NXP control unit gives the flexibility to create advanced features with options and programmability. See selection guide and application manual for full list of features.

The control unit of the AC drive contains the control board and additional boards (see [Illustration 25](#)) connected to the 5 slot connectors (A to E) of the control board. The control board is connected to the power unit through a D-connector or fiber optic cables (FR9–FR11).

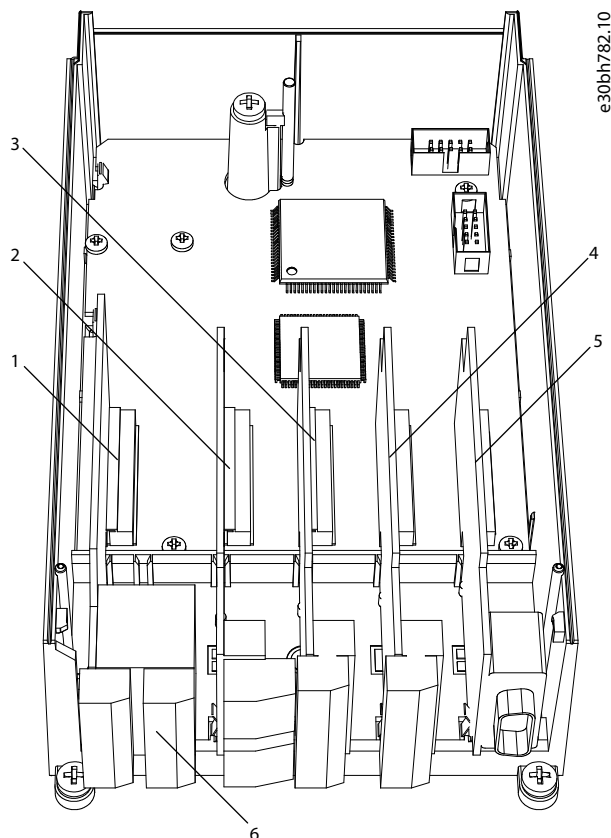

Illustration 25: Basic and Option Slots on the Control Board

1	Slot A; OPTA1	4	Slot D; option boards
2	Slot B; OPTA2	5	Slot E; option boards
3	Slot C; OPTA3	6	Control terminals

The control unit of the delivered AC drive contains the standard control interface. If the order included special options, the AC drive is delivered according to the order. The next pages contain information on the terminals and general wiring examples. The type code shows the I/O boards that are installed at the factory. For more information on the option boards, see VACON[®]NX I/O Boards User manual.

The OPTA1 basic board has 20 control terminals, and the relay board has 6 or 7. The standard connections of the control unit and the descriptions of signals are shown in [7.3.2 Control Terminals on OPTA1](#).

For instructions on how to install the control unit that is not attached to the power unit, see VACON[®]NXP IP00 Drives Installation Manual.

7.2 Control Voltage (+24 V/EXT +24 V)

It is possible to use the drive with an external power source with these properties: +24 V DC $\pm 10\%$, minimum 1000 mA. Use it to externally power up the control board, and the basic and option boards. The analog outputs and inputs at OPTA1 do not work with only +24 V supplied to the control unit.

Connect the external power source to one of the 2 bidirectional terminals (#6 or #12), see the option board manual or VACON[®] NX I/O Boards User Manual. With this voltage, the control unit stays on and parameters can be set. The measurements of the main circuit (for example, the DC-link voltage, and the unit temperature) are not available when the drive is not connected to mains.

NOTICE

If the AC drive is supplied with external 24 V DC power, use a diode in terminal #6 (or #12) to prevent the current to flow in opposite direction. Put a 1 A fuse in 24 V DC line for each AC drive. The maximum current consumption of each drive is 1 A from the external supply.

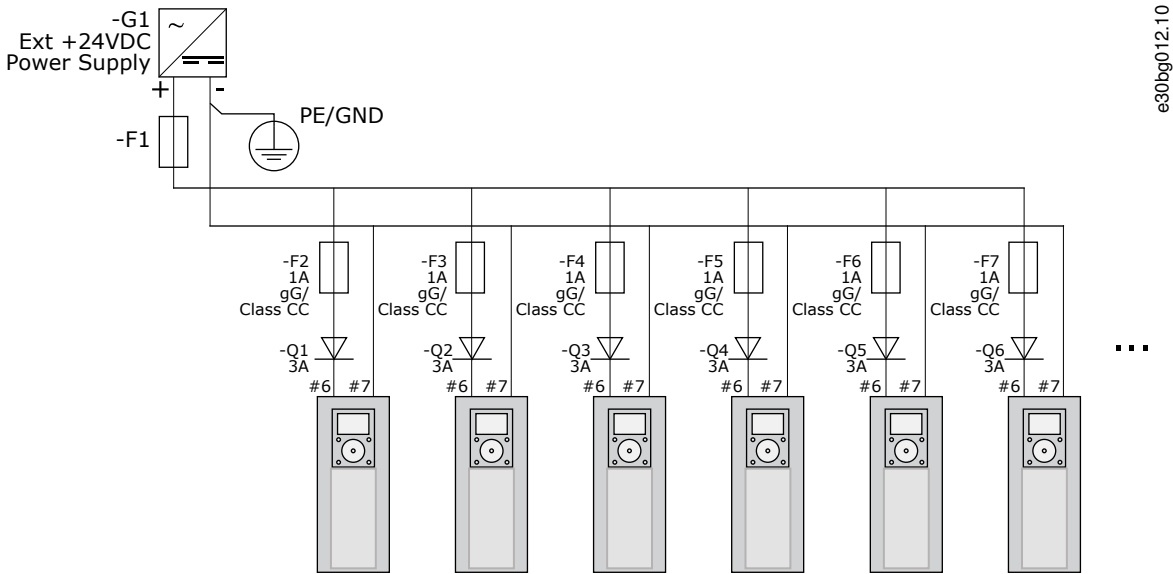

Illustration 26: Parallel Connection of 24 V Inputs with Many AC Drives

NOTICE

The control unit I/O ground is not isolated from the chassis ground/protective earth. In the installation, consider the potential differences between the grounding points. We recommend using galvanic isolation in the I/O and 24 V circuitry.

7.3 Control Unit Cabling

7.3.1 Selection of the Control Cables

The control cables must be a minimum of 0.5 mm² (20 AWG) shielded multicore cables. See more on the cable types in [Table 9](#). The terminal wires must be a maximum of 2.5 mm² (14 AWG) for the terminals of the relay board and 1.5 mm² (16 AWG) for other terminals.

Table 11: Tightening Torques of the Control Cables

The terminal	The terminal screw	The tightening torque in Nm (lb-in.)
Relay and thermistor terminals	M3	0.5 (4.5)
Other terminals	M2.6	0.2 (1.8)

7.3.2 Control Terminals on OPTA1

The figure shows the basic description of the terminals of the I/O board. For more information, see [7.3.2.2 Jumper Selections on the OPTA1 Basic Board](#). For more information on control terminals, see VACON[®] All in One Application manual.

		Standard I/O board		
		Terminal	Signal	Description
	1	+10V _{ref}	Reference voltage	Maximum current 10 mA
	2	AI1+	Analogue input, voltage or current	Selection V/mA with jumper block X1 (*) 0...+10 V (R _i = 200 kΩ) (-10V...+10V Joystick ctrl, sel. with jumper) 0-20 mA (R _i = 250 Ω)
	3	GND/AI1-	Analogue input common	Differential input if not connected to ground Allows ±20 V common mode voltage to GND
	4	AI2+	Analogue input, voltage or current	Selection V/mA with jumper block X1 (*) 0...+10 V (R _i = 200 kΩ) (-10V...+10V Joystick ctrl, sel. with jumper) 0-20 mA (R _i = 250 Ω)
	5	GND/AI2-	Analogue input common	Differential input if not connected to ground Allows ±20 V common mode voltage to GND
	6	+24V	24 V aux. voltage	±15%, max. 250 mA (all boards total) 150 mA (from single board) Can also be used as external power back-up for the control unit (and fieldbus)
	7	GND	I/O ground	Ground for reference and controls
	8	DIN1	Digital input 1	R _i = min. 5 kΩ 18-30 V = 1
	9	DIN2	Digital input 2	
	10	DIN3	Digital input 3	
	11	CMA	Common A for DIN1—DIN3	Digital inputs can be disconnected from ground (*)
	12	+24V	Control voltage output	Same as terminal #6
	13	GND	I/O ground	Same as terminal #7
	14	DIN4	Digital input 4	R _i = min. 5 kΩ 18-30 V = 1
	15	DIN5	Digital input 5	
	16	DIN6	Digital input 6	
	17	CMB	Common B for DIN4-DIN6	Must be connected to GND or 24 V of I/O term. or to ext.24 V or GND Selection with jumper block X3 (*)
	18	AO1+	Analogue signal (+output)	Output signal range: Current 0(4)-20 mA, R _L max 500 Ω or Voltage 0-10 V, R _L >1kΩ Selection with jumper block X6 (*)
	19	AO1-	Analogue output common	
	20	DO1	Open collector output	Maximum U _{in} = 48 VDC Maximum current = 50 mA

e30bg013.10

Illustration 27: Control Terminal Signals on OPTA1

*) See figure in [7.3.2.2 Jumper Selections on the OPTA1 Basic Board](#)

Parameter references for I/O on control panel and NCDrive are: An.IN:A.1, An.IN:A.2, DigIN:A.1, DigIN:A.2, DigIN:A.3, DigIN:A.4, DigIN:A.5, DigIN:A.6, AnOUT:A.1 and DigOUT:A.1.

To use the control voltage output +24 V/EXT+24 V:

- Wire the +24 V control voltage to digital inputs through an external switch. OR
- Use the control voltage to power up external equipment, such as encoders and auxiliary relays.

The specified total load on all available +24 V/EXT+24 V output terminals must not exceed 250 mA.

The maximum load on the +24 V/EXT+24 V output per board is 150 mA. If there is a +24 V/EXT+24 V output on the board, it is locally short circuit protected. If one of the +24 V/EXT+24 V outputs short circuits, the others remain powered because of the local protection.

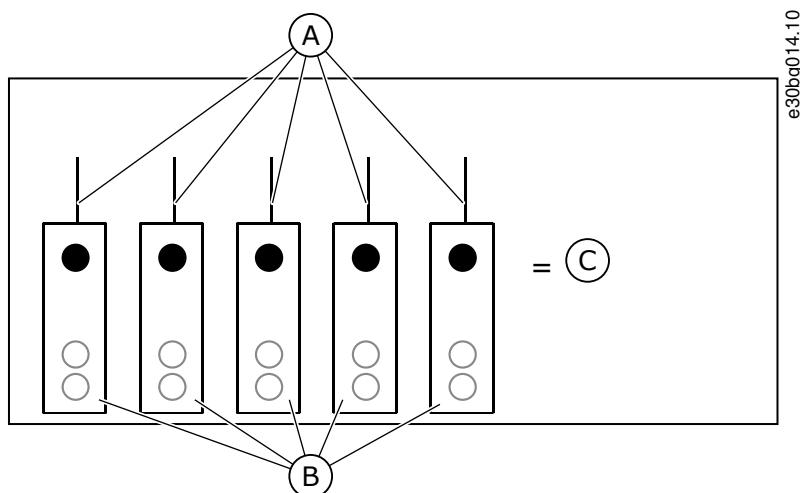

Illustration 28: Maximum Loads on +24 V/EXT+24 V Output

<p>A Maximum 150 mA</p> <p>B +24 V out</p>	<p>C Maximum 250 mA</p>
--	------------------------------

7.3.2.1 Digital Input Signal Inversions

The active signal level is different when the common inputs CMA and CMB (terminals 11 and 17) are connected to +24 V or to ground (0 V).

The 24 V control voltage and the ground for the digital inputs and the common inputs (CMA, CMB) can be internal or external.

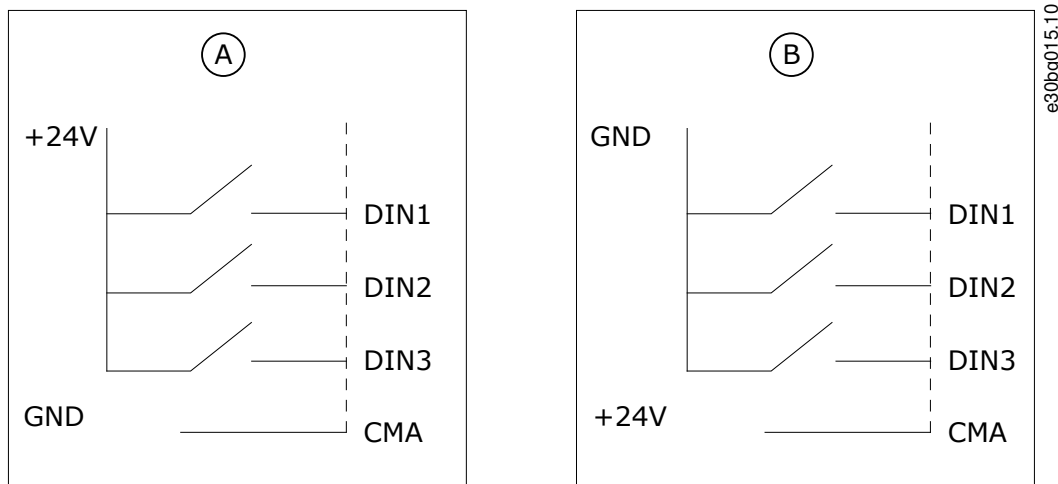

Illustration 29: Positive/Negative Logic

<p>A Positive logic (+24 V is the active signal) = the input is active when the switch is closed.</p>	<p>B Negative logic (0 V is the active signal) = the input is active when the switch is closed. Set the jumper X3 to the position 'CMA/CMB isolated from ground'.</p>
--	--

Related Links

- [Jumper Selections on the OPTA1 Basic Board](#)

7.3.2.2 Jumper Selections on the OPTA1 Basic Board

The functions of the AC drive can be changed to make them better agree with local requirements. To do it, change some positions for the jumpers on the OPTA1 board. The positions of the jumpers set the signal type of analog and digital inputs. Changing the AI/AO signal contents requires also a change in the related board parameter in menu M7.

On the A1 basic board, there are 4 jumper blocks: X1, X2, X3, and X6. Each jumper block contains 8 pins and 2 jumpers. See the possible jumper selections in [Illustration 30](#).

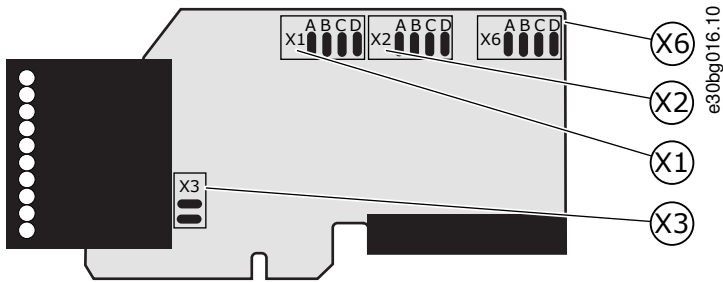
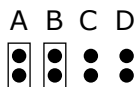

Illustration 30: Jumper Blocks on OPTA1

e30bg017.10

Jumper block X1:
AI1 mode



AI1 mode: 0...20mA; Current input

Jumper block X2:
AI2 mode

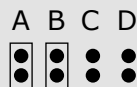

AI2 mode: 0...20mA; Current input

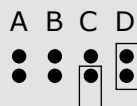

AI1 mode: Voltage input; 0...10V

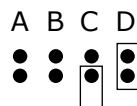

AI2 mode: Voltage input; 0...10V

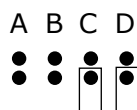

AI1 mode: Voltage input; 0...10V differential

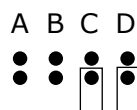

AI2 mode: Voltage input; 0...10V differential

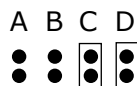

AI1 mode: Voltage input; -0...10V

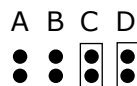

AI2 mode: Voltage input; -10...10V

Jumper block X6:
AO1 mode

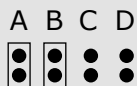

AO1 mode: 0...20mA; Current output

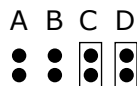

AO1 mode: Voltage output; 0...10V

Jumper block X3:
CMA and CMB grounding

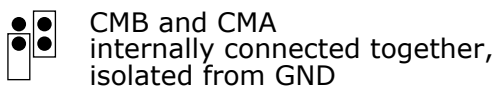
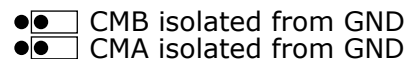
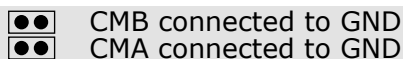

= Factory default

Illustration 31: Jumper Selections for OPTA1

7.3.3 Control Terminals on OPTA2 and OPTA3

OPTA2				e30bg018.10
21	RO1/1	Relay output 1 DigOUT:B.1 *)	Switching capacity • 24 VDC/8 A • 250 VAC/8 A • 125 VDC/0.4 A Minimum switching load • 5 V/10 mA	
22	RO1/2			
23	RO1/3			
24	RO2/1	Relay output 2 DigOUT:B.2 *)	Switching capacity • 24 VDC/8 A • 250 VAC/8 A • 125 VDC/0.4 A Minimum switching load • 5 V/10 mA	
25	RO2/2			
26	RO2/3			
OPTA3				
21	RO1/1	Relay output 1 DigOUT:B.1 *)	Switching capacity • 24 VDC/8 A • 250 VAC/8 A • 125 VDC/0.4 A Minimum switching load • 5 V/10 mA	
22	RO1/2			
23	RO1/3			
25	RO2/1	Relay output 2 DigOUT:B.2 *)	Switching capacity • 24 VDC/8 A • 250 VAC/8 A • 125 VDC/0.4 A Minimum switching load • 5 V/10 mA	
26	RO2/2			
28	TI1+			
29	TI1-	Thermistor input DigIN:B.1 *)		

Illustration 32: Control Terminal Signals on Relay Boards OPTA2 and OPTA3

*) Parameter reference on control panel and NCDrive.

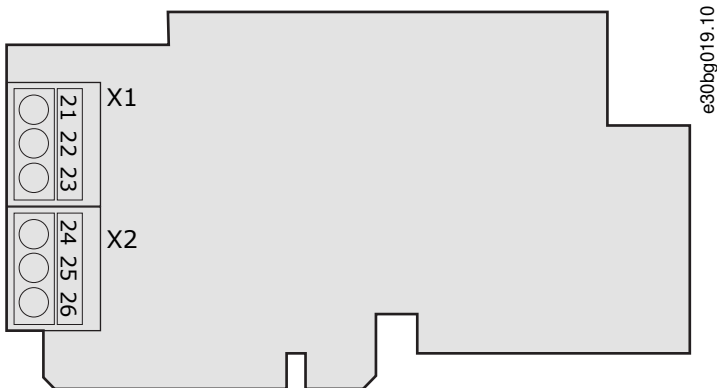

Illustration 33: OPTA2

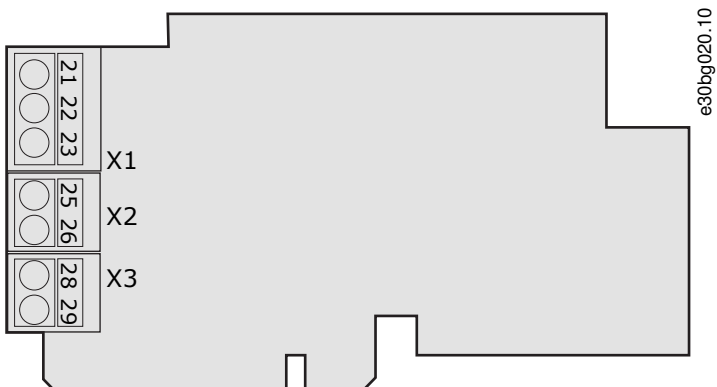

Illustration 34: OPTA3

7.4 Installation of Option Boards

For information on how to install the option boards, see the option board manual or VACON[®] NX I/O Boards User Manual.

7.5 Galvanic Isolation Barriers

The control connections are isolated from mains. The GND terminals are permanently connected to I/O ground. See [Illustration 35](#). The digital inputs on the I/O board are galvanically isolated from the I/O ground (PELV). The relay outputs are also double-isolated from each other at 300 VAC (EN-50178).

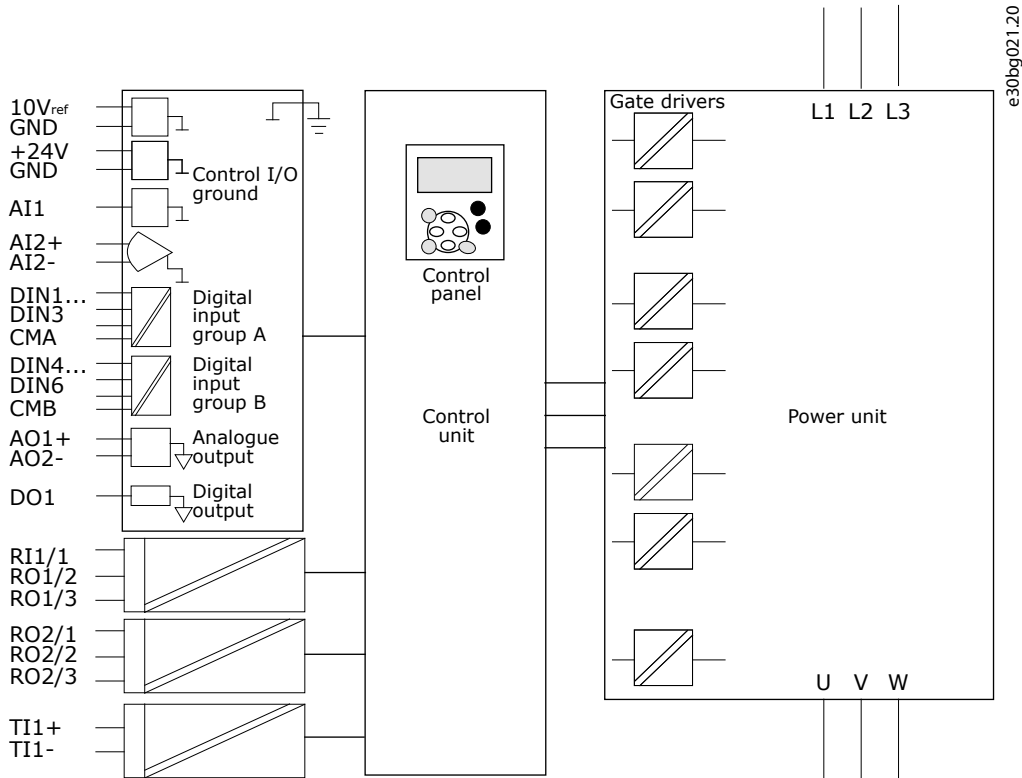

Illustration 35: Galvanic Isolation Barriers

8 Using the Control Panel

8.1 Navigating on the Control Panel

The data of the AC drive is in menus and submenus. Follow these instructions to navigate in the menu structure on the control panel.

Procedure

1. To move between the menus, use the Browser buttons Up and Down on the keypad.
2. To go into a group or an item, push the Menu button Right.

To go back to the previous level, push the Menu button Left.

➔ The display shows the current location in the menu, for example S6.3.2. The display also shows the name of the group or item in the current location.

Illustration 36: Navigation Items on the Control Panel

A	The location on the menu	C	The number of items that are available or the item value.
B	The description (name of the page)		

8.2 Using the Monitoring Menu (M1)

Follow these instructions to monitor the actual values of the parameters and signals.

The values cannot be changed in the Monitoring menu. To change the values of parameters, see [8.3.2 Selecting Values](#) or [8.3.3 Editing the Values Digit by Digit](#).

Procedure

1. To find the Monitoring menu, scroll down in the main menu until the location indication M1 shows on the first line of the display.

➔

2. To go to the Monitoring menu from the main menu, push the Menu button Right.
3. To scroll through the menu, push the Browser buttons Up and Down.

8.2.1 Monitored Values

The monitored values have the indication V#.#. The values update each 0.3 s.

Index	Monitored value	Unit	ID	Description
V1.1	Output frequency	Hz	1	The output frequency to the motor
V1.2	Frequency reference	Hz	25	The frequency reference to motor control
V1.3	Motor speed	rpm	2	The actual speed of the motor in rpm
V1.4	Motor current	A	3	Measured motor current
V1.5	Motor torque	%	4	The calculated shaft torque
V1.6	Motor power	%	5	The calculated motor shaft power in percentage
V1.7	Motor voltage	V	6	The output voltage to the motor
V1.8	DC link voltage	V	7	The measured voltage in the DC-link of the drive
V1.9	Unit temperature	°C	8	The heat sink temperature in Celsius or Fahrenheit
V1.10	Motor temperature	%	9	The calculated motor temperature in percentage of the nominal temperature. See VACON® All in One Application Manual.
V1.11	Analog input 1	V/mA	13	AI1 ⁽¹⁾
V1.12	Analog input 2	V/mA	14	AI2 ⁽¹⁾
V1.13	DIN 1, 2, 3	–	15	Shows the status of the digital inputs 1–3
V1.14	DIN 4, 5, 6	–	16	Shows the status of the digital inputs 4–6
V1.15	DO1, RO1, RO2	–	17	Shows the status of the digital and relay outputs 1–3
V1.16	Analog I _{out}	mA	26	AO1
V1.17	Multimonitored items	–	–	Shows 3 monitored values to select from. See 8.7.6.9 Enabling/Disabling the Change of Multimonitored Items .

¹ If the AC drive only has +24 V supply (for control board power-up), this value is not reliable.

See VACON® All in One Application Manual for more monitored values.

8.3 Using the Parameter Menu (M2)

8.3.1 Finding the Parameter

Use these instructions to find the parameter to edit.

Procedure

1. To find the Parameter menu, scroll down in the main menu until the location indication *M2* shows on the first line of the display.

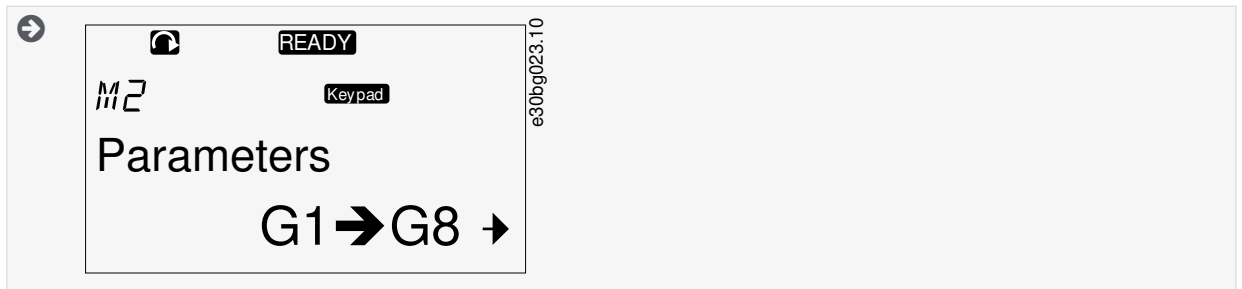

2. Push the Menu button Right to move into the Parameter Group Menu (G#).



3. To find the parameter group, use the Browser buttons Up and Down.



4. Use the Browser buttons Up and Down to find the parameter (P#) to edit. To move directly from the last parameter of a parameter group to the first parameter of that group, push the Browser button Up.



8.3.2 Selecting Values

Use these instructions to edit the text values on the control panel.

The basic application package "All in One+" includes 7 applications with different sets of parameters. For more information, see VACON® All in One Application Manual.

When the drive is in RUN state, many parameters are locked, and cannot be edited. Only the text *Locked* shows on the display. Stop the AC drive to edit these parameters.

Procedure

1. Use the Browser buttons Up and Down to find the parameter (P#) to edit. To move directly from the last parameter of a parameter group to the first parameter of that group, push the Browser button Up.

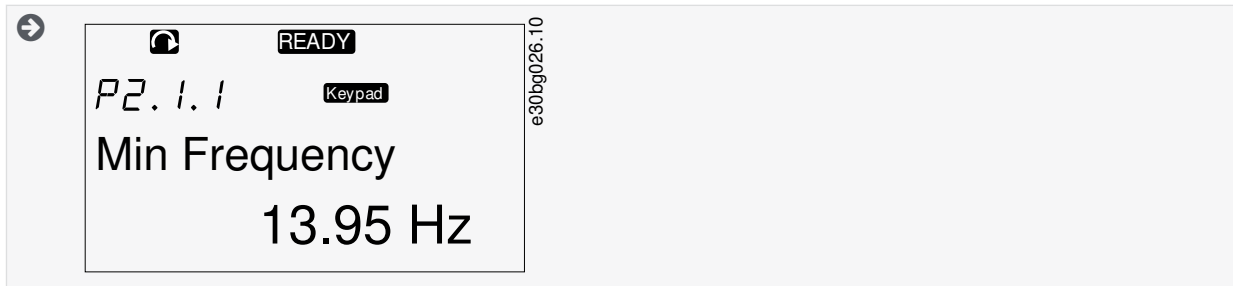

2. To go to the Edit mode, push the Menu button Right. The parameter value starts to blink.

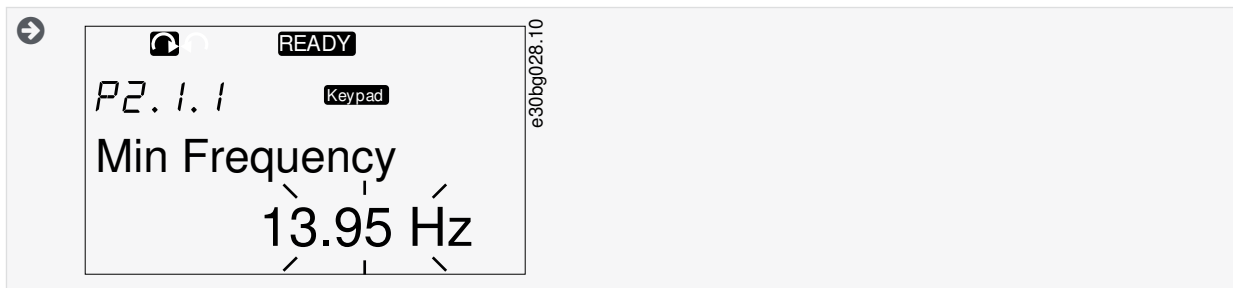

3. Set the new value with the Browser buttons Up and Down.
4. To accept the change, push the [enter] button or ignore the change with menu button Left.

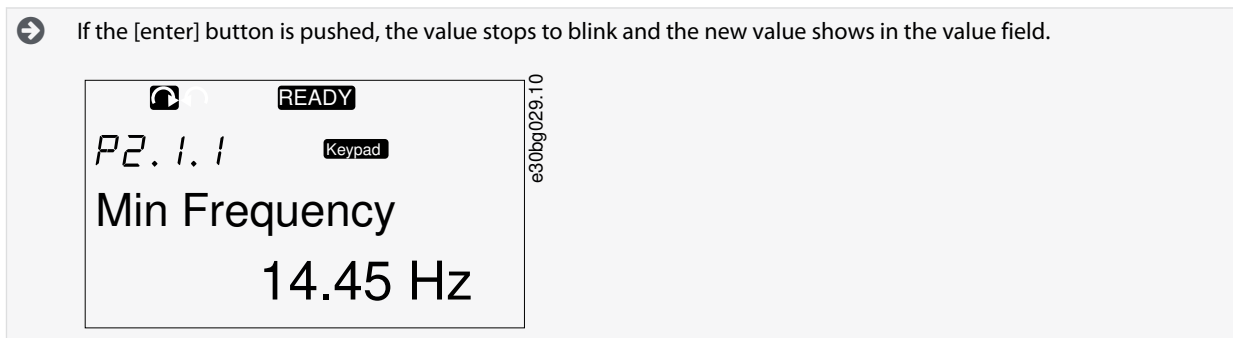

5. For locking the parameter values, use the *Parameter Lock* function in menu M6, see [8.7.6.6 Locking a Parameter](#).

8.3.3 Editing the Values Digit by Digit

Use these instructions to edit the numerical values on the control panel.

The basic application package "All in One+" includes 7 applications with different sets of parameters. For more information, see VACON® All in One Application Manual.

When the drive is in RUN state, many parameters are locked, and cannot be edited. Only the text *Locked* shows on the display. Stop the AC drive to edit these parameters.

Procedure

1. Find the parameter with the Browser and Menu buttons.

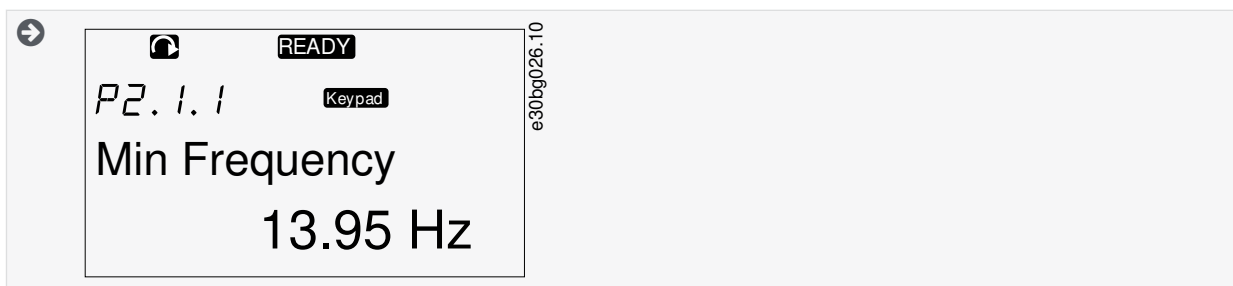

- To go to the Edit mode, push the Menu button Right. The parameter value starts to blink.

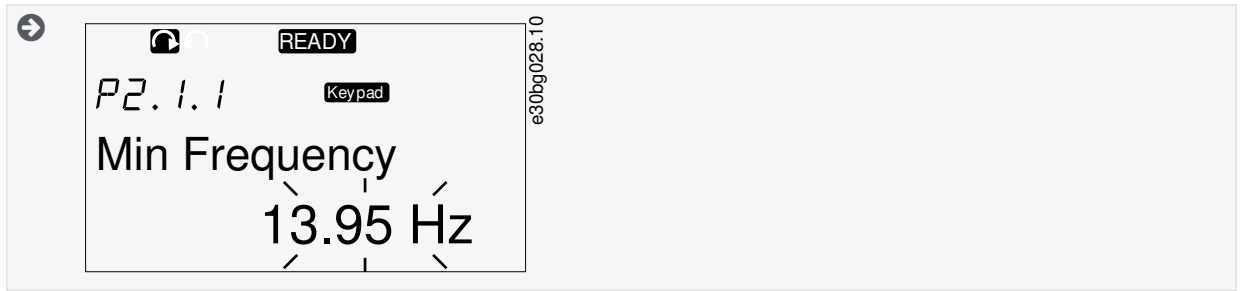

- Push the Menu button Right. The value can now be edited digit by digit.
- To accept the change, push the [enter] button.

To ignore the change, push Menu button Left many times, until the view goes back to the parameter list.

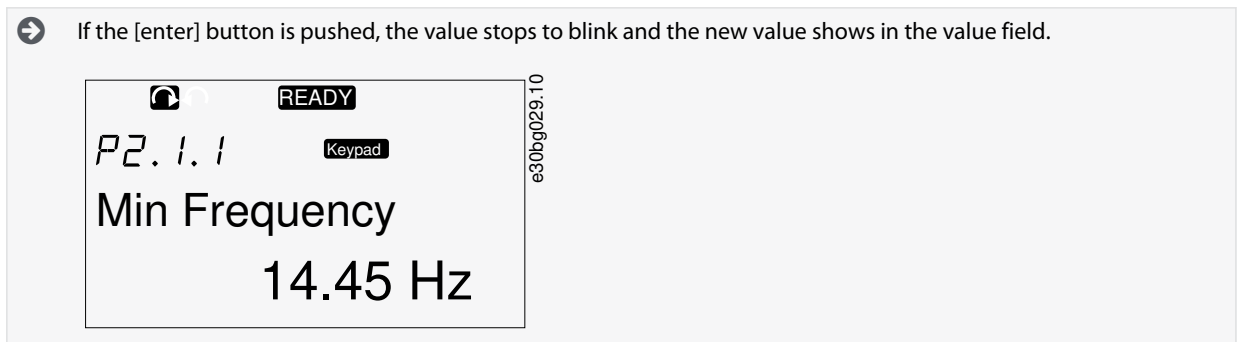

- For locking the parameter values, use the *Parameter Lock* function in menu *M6*, see [8.7.6.6 Locking a Parameter](#).

8.4 Using the Keypad Control Menu

8.4.1 Finding the Keypad Control Menu

In the Keypad control menu, the following functions are available: selecting the control mode, editing the frequency reference, and changing the direction of the motor.

Procedure

- To find the *Keypad control* menu, scroll down in the main menu until the location indication *M3* shows on the first line of the display.

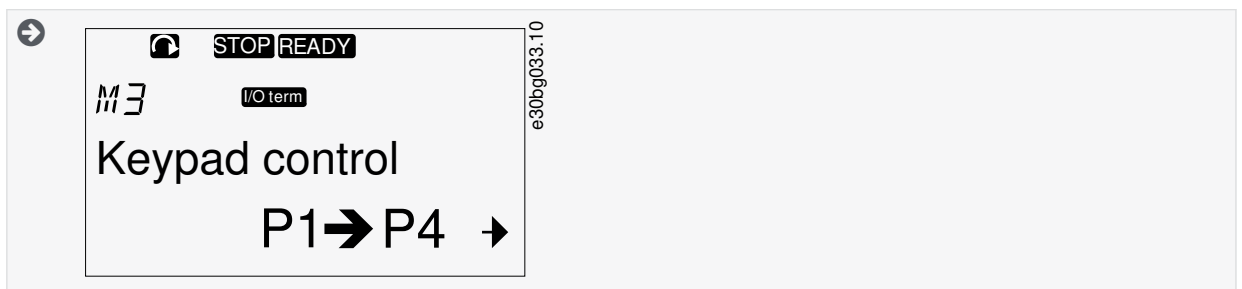

- To go to the *Keypad control* menu from the main menu, push the Menu button Right.

8.4.2 Keypad Control Parameters M3

Index	Parameter	Min	Max	Unit	Default	Cust	ID	Description
P3.1	Control place	1	3	–	1		125	The control mode 1 = I/O terminal 2 = Keypad (control panel)

Index	Parameter	Min	Max	Unit	Default	Cust	ID	Description
								3 = Fieldbus
R3.2	Keypad reference	P2.1.1	P2.1.2	Hz	0.00		123	0 = Forward 1 = Reverse
P3.3	Direction (on keypad)	0	1	-	0		-	-
P3.4	Stop button	0	1	-	1		114	0 = Limited function of Stop button 1 = Stop button always enabled

8.4.3 Changing the Control Mode

3 control modes are available to control the AC drive. For each control place, a different symbol shows on the display:

The control mode	The symbol
I/O terminals	
Keypad (control panel)	
Fieldbus	

Procedure

1. In the *Keypad control* menu (M3), find the control mode (*Control Place*) with Menu buttons Up and Down.

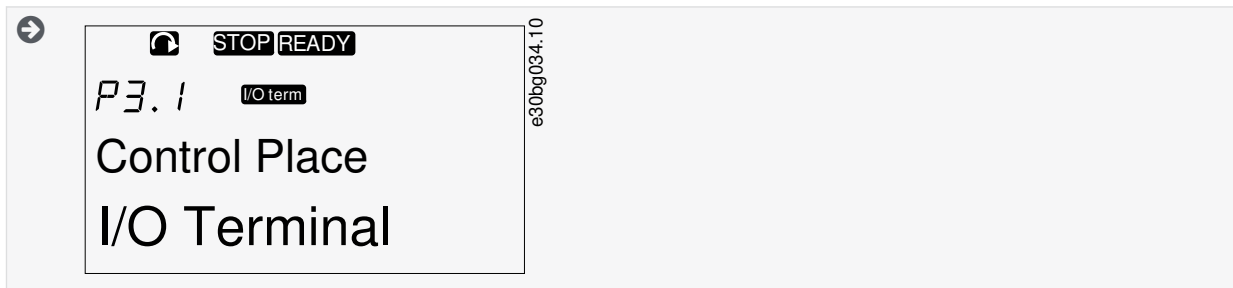

2. To go to the edit mode, push the Menu button Right.

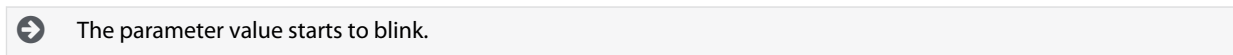

3. To scroll through the options, push the Browser buttons Up and Down.
4. To select the control mode, push the [enter] button.

8.4.4 Keypad Reference

The keypad reference submenu (P3.2) shows the frequency reference. In this submenu, also the frequency reference can be edited.

8.4.4.1 Editing the Frequency Reference

Use these instructions to change the frequency reference.

Procedure

1. In the *Keypad control* menu (M3), find the Keypad reference with Menu buttons Up and Down.
2. To go to the edit mode, push the Menu button Right. The frequency reference value starts to blink.
3. Set the new value with the Browser buttons.

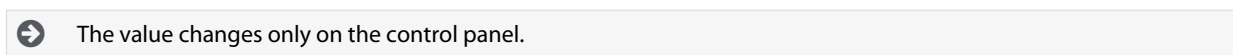

4. To make the motor speed to agree with the value on the control panel, select the keypad as the control mode, see [8.4.3 Changing the Control Mode](#).

8.4.5 Changing the Rotation Direction

The keypad direction submenu shows the rotation direction of the motor. In this submenu, also the rotation direction can be changed.

For more information on how to control the motor with the control panel, see [3.10.1 Keypad](#) and [9.2 Commissioning the Inverter](#).

Procedure

1. In the *Keypad control* menu (M3), find the Keypad direction with the Menu buttons Up and Down.
2. To go to the edit mode, push the Menu button Right.
3. Select the direction with Menu buttons Up and Down.

 The rotation direction changes on the control panel.

4. To make the motor to agree with the set rotation direction, select the keypad as the control mode, see [8.4.3 Changing the Control Mode](#).

8.4.6 Disabling the Stop Motor Function

As a default, the motor stops when the Stop button is pushed no matter what is the control mode. Use these instructions to disable this function.

Procedure

1. In the *Keypad control* menu (M3), find the page 3.4. Stop button with the Browser buttons.
2. To go to the edit mode, push the Menu button Right.
3. To select Yes or No, use the Browser buttons.
4. Accept the selection with the [enter] button.

 When the Stop motor function is not active, the Stop button stops the motor only when the keypad is the control mode.

8.4.7 Special Functions in Keypad Control Menu

8.4.7.1 Selecting the Keypad as the Control Mode

This is a special function only available in menu M3.

Make sure to be in the menu M3 and control mode is other than keypad.

Procedure

1. Do one of the following options:
 - Keep the Start button pushed down for 3 s when the motor is in RUN state.
 - Keep the Stop button pushed down for 3 s when the motor is stopped.

In other menu than M3, when the keypad is not the active control mode and the start button is pushed, an error message *Keypad Control NOT ACTIVE* shows. In some applications this error message is not shown.

 The keypad is selected as the control mode and the current frequency reference and direction is copied to the control panel.

8.4.7.2 Copying the Frequency Reference Set to the Control Panel

These are special functions only available in menu M3.

Use these instructions to copy the frequency reference set from I/O or fieldbus to control panel.

Make sure to be in menu M3 and that the control mode is other than keypad.

Procedure

1. Keep the [enter] button pushed down for 3 s.

In other menu than M3, when the keypad is not the active control mode and the start button is pushed, an error message *Keypad Control NOT ACTIVE* shows.

8.5 Using the Active Faults Menu (M4)

8.5.1 Finding the Active Faults Menu

The Active faults menu shows a list of active faults. When there are no active faults, the menu is empty.

For more information on the fault types and how to reset faults, see [11.1 General Information on Fault Tracing](#) and [11.2 Resetting a Fault](#). For the fault codes, possible causes and information on how to correct the fault, see the Faults and Alarms section.

Procedure

1. To find the *Active faults* menu, scroll down in the main menu until the location indication *M4* shows on the first line of the display.

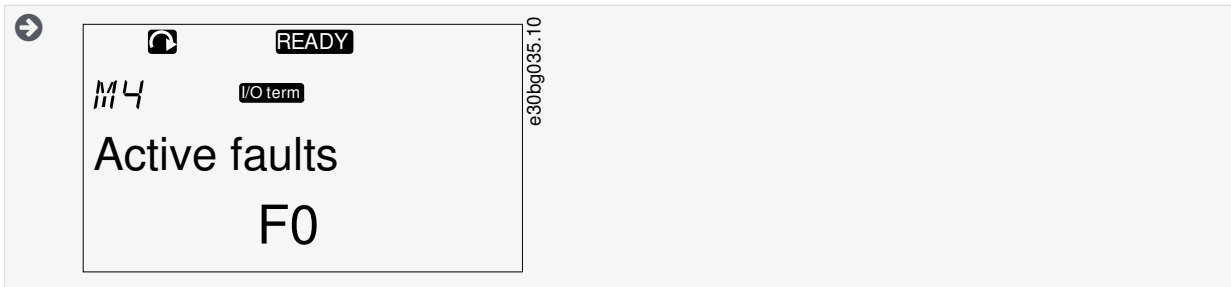

2. To go to the *Active faults* menu from the main menu, push the Menu button Right.

➔ If there is a fault in the display, these symbols show:

The screenshot shows a control panel display with a navigation arrow on the left. The display content includes a home icon, the word 'STOP', and 'I/O term'. The main text reads 'F I', '11 Output phase', and 'F T1 → T13 →'. A 'FAULT' indicator is in the top right corner. Callout 'A' points to the 'FAULT' indicator, and callout 'B' points to the 'F' fault symbol. A vertical reference code 'e30hg036.10' is on the right side.

Illustration 37: Fault Symbols

A	Fault symbol
B	Fault type symbol

8.5.2 Examining the Fault Time Data Record

This menu shows some important data that was valid at the time of the fault. This helps to find the cause of the fault.

Procedure

1. Find the fault in *Active faults* menu or *Fault history* menu.
2. Push the Menu button Right.
3. Scroll the data *T.1-T.16* with the Browser buttons.

8.5.3 Fault Time Data Record

The fault time data record shows some important data that was valid at the time of the fault. This helps to find the cause of the fault. If real time is set on the AC drive, the data items *T1* and *T2* show as in column Real Time Data Record.

In some special cases, some of the fields can show other data than described in the table. If the value of a field differs significantly from the expected value, this special usage can be the reason. Contact the nearest distributor to get help from the factory in understanding the data.

Code	Description	Value	Real Time Data Record
T.1	Counted operation days	d	yyyy-mm-dd
T.2	Counted operation hours	hh:mm:ss (d)	hh:mm:ss,sss
T.3	Output frequency	Hz (hh:mm:ss)	–
T.4	Motor current	A	–
T.5	Motor voltage	V	–
T.6	Motor power	%	–
T.7	Motor torque	%	–
T.8	DC voltage	V	–
T.9	Unit temperature	°C	–
T.10	Run status	–	–
T.11	Direction	–	–
T.12	Warnings	–	–
T.13	0-speed ⁽¹⁾	–	–
T.14	Subcode	–	–
T.15	Module	–	–
T.16	Submodule	–	–

¹ Tells if the drive was at zero speed (< 0.01 Hz) when the fault showed.

8.6 Using the Fault History Menu (M5)

8.6.1 Fault History Menu (M5)

There is a maximum number of 30 faults in the Fault history. The information on each fault shows in the Fault time data record, see [8.5.3 Fault Time Data Record](#).

The value line of the main page (H1->H#) shows the number of faults in the fault history. The location indication tells in which order the faults have shown. The newest fault has the indication *H5.1*, the second newest *H5.2*, and so on. If there are 30 faults in the history, the next fault that shows removes the oldest one (*H5.30*) from the history.

See the different fault codes in the Faults and Alarms section.

8.6.2 Resetting the Fault History

The Fault History shows 30 latest faults at a time. Use these instructions to reset the history.

Procedure

1. To find the *Fault history* menu, scroll down in the main menu until the location indication *M5* shows on the first line of the display.
2. To go to the *Fault history* menu from the main menu, push the Menu button Right.

- In the *Fault history* menu, push the [enter] button for 3 s.

➔ The symbol H# changes to 0.

8.7 Using the System Menu (M6)

8.7.1 Finding the System Menu

The System menu includes the general settings of the AC drive. These are, for example, application selection, parameter sets and information about the hardware and software. The number of submenus and subpages shows as the symbol S# (or P#) on the value line.

Procedure

- To find the System menu, scroll down in the main menu until the location indication M6 shows on the first line of the display.
- To go to the System menu from the main menu, push the Menu button Right.



8.7.2 System Menu Functions

Table 12: System Menu Functions

Code	Function	Min	Max	Unit	Default	Cust	Description
S6.1	Language selection	-	-	-	English		The selection is different in all the language packages
S6.2	Application selection	-	-	-	Basic application		Basic application Standard application Local/Remote control appl. Multi-Step application PID Control application Multi-Purpose Control appl. Pump and Fan Control appl.
S6.3	Copy parameters	-	-	-	-		-
S6.3.1	Parameter sets	-	-	-	-		Store set 1 Load set 1 Store set 2 Load set 2 Load factory defaults
S6.3.2	Load up to keypad	-	-	-	-		All parameters
S6.3.3	Load down from keypad	-	-	-	-		All parameters All but motor parameters

Code	Function	Min	Max	Unit	Default	Cust	Description
							Application parameters
P6.3.4	Parameter back-up	-	-	-	Yes		Yes No
S6.4	Compare parameters	-	-	-	-		-
S6.4.1	Set1	-	-	-	Not used		-
S6.4.2	Set 2	-	-	-	Not used		-
S6.4.3	Factory settings	-	-	-	-		-
S6.4.4	Keypad set	-	-	-	-		-
S6.5	Security	-	-	-	-		-
S6.5.1	Password	-	-	-	Not used		0 = Not used
P6.5.2	Parameter lock	-	-	-	Change Enabled		Change Enabled Change Disabled
S6.5.3	Start-up wizard	-	-	-	-		No Yes
S6.5.4	Multimonitoring items	-	-	-	-		Change Enabled Change Disabled
S6.6	Keypad settings	-	-	-	-		-
P6.6.1	Default page	-	-	-	-		-
P6.6.2	Default page/ Operating menu	-	-	-	-		-
P6.6.3	Timeout time	0	65535	s	30		-
P6.6.4	Contrast	0	31	-	18		-
P6.6.5	Backlight time	Always	65535	min	10		-
S6.7	Hardware settings	-	-	-	-		-
P6.7.1	Internal brake resistor	-	-	-	Connected		Not connected Connected
P6.7.2	Fan control	-	-	-	Continuous		Continuous Temperature First start Calc temp
P6.7.3	HMI acknowledg. timeout	200	5000	ms	200		-

Code	Function	Min	Max	Unit	Default	Cust	Description
P6.7.4	HMI number of retries	1	10	–	5		–
P6.7.5	Sine filter	–	–	–	Connected		Not connected Connected
S6.8	System information	–	–	–	–		–
S6.8.1	Total counters	–	–	–	–		–
C6.8.1.1	MWh counter	–	–	kWh	–		–
C6.8.1.2	Power On day counter	–	–	–	–		–
C6.8.1.3	Power On hours counter	–	–	hh:mm:ss	–		–
S6.8.2	Trip counters	–	–	–	–		–
T6.8.2.1	MWh counter	–	–	kWh	–		–
T6.8.2.2	Clear MWh trip counter	–	–	–	–		–
T6.8.2.3	Operating days trip counter	–	–	–	–		–
T6.8.2.4	Operating hours trip counter	–	–	hh:mm:ss	–		–
T6.8.2.5	Clear operating time counter	–	–	–	–		–
S6.8.3	Software info	–	–	–	–		–
S6.8.3.1	Software package	–	–	–	–		–
S6.8.3.2	System software version	–	–	–	–		–
S6.8.3.4	System load	–	–	–	–		–
S6.8.4	Applications	–	–	–	–		–
S6.8.4.#	Name of application	–	–	–	–		–
D6.8.4.#. 1	Application ID	–	–	–	–		–
D6.8.4.#. 2	Applications: Version	–	–	–	–		–
D6.8.4.#. 3	Applications: Firmware interface	–	–	–	–		–
S6.8.5	Hardware	–	–	–	–		–
I6.8.5.1	Info: Power unit type code	–	–	–	–		–
I6.8.5.2	Info: Unit voltage	–	–	–	–		–

Code	Function	Min	Max	Unit	Default	Cust	Description
I6.8.5.3	Info: Brake chopper	–	–	–	–		–
I6.8.5.4	Info: Brake resistor	–	–	–	–		–
S6.8.6	Expander boards	–	–	–	–		–
S6.8.7	Debug menu	–	–	–	–		For Application programming only. Speak to the factory to get instructions.

8.7.3 Changing the Language

Use these instructions to change the language of the control panel. The possible languages are different in all language packages.

Procedure

1. In the *System* menu (*M6*), find the *Language* selection page (*S6.1*) with the Browser buttons.
2. To go to the edit mode, push the Menu button Right.

↩ The name of the language starts to blink.

3. To select the language for the control panel texts, use the Menu buttons Up and Down.
4. To accept the selection, push the [enter] button.

↩ The name of the languages stops to blink and all text information on the control panel shows in the selected language.

8.7.4 Changing the Application

The application can be changed in the *Application* selection page (*S6.2*). When the application is changed, all parameters are reset. For more information on the Application Package, see VACON[®]NX All in One Application Manual.

Procedure

1. In the *System* menu (*M6*), find the *Application* selection page (*S6.2, Application*) with the Browser buttons.
2. Push the Menu button Right.
3. To go to the edit mode, push the Menu button Right.

↩ The name of the application starts to blink.

4. Scroll through the applications with the Browser buttons and select a different application.
5. To accept the selection, push the [enter] button.

↩ The AC drive starts again and goes through the set-up.

6. When the display shows the question *Copy parameters?*, there are 2 options:

This question shows only if the parameter *P6.3.4 Parameter back-up* is set to *Yes*.

- To upload the parameters of the new application to the control panel, select *Yes* with the Browser buttons.
- To keep the parameters of the application that was last used in the control panel, select *No* with the Browser buttons.

8.7.5 Copy Parameters (S6.3)

Use this function to copy parameters from one AC drive to a different AC drive or to save parameter sets in the internal memory of the AC drive.

Stop the AC drive before copying or downloading parameters.

8.7.5.1 Saving Parameter Sets (Parameter Sets S6.3.1)

Use this function to get the factory default values back or save 1–2 customized parameter sets. A parameter set includes all parameters of the application.

Procedure

1. In the Copy parameters (S6.3) subpage, find the *Parameter sets (S6.3.1)* with the Browser buttons.
2. Push the Menu button Right.
3. To go to the edit mode, push the Menu button Right.

 The text *LoadFactDef* starts to blink.

4. There are 5 options to select from. Select the function with the Browser buttons.
 - Select *LoadFactDef* to download again the factory default values.
 - Select *Store set 1* to save actual values of all parameters as set 1.
 - Select *Load set 1* to download the values in set 1 as the actual values.
 - Select *Store set 2* to save actual values of all parameters as set 2.
 - Select *Load set 2* to download the values in set 2 as the actual values.
5. To accept the selection, push the [enter] button.
6. Wait until *OK* shows on the display.

8.7.5.2 Uploading Parameters to Control Panel (Up To Keypad, S6.3.2)

Use this function to upload all parameter groups to the control panel when the AC drive is stopped.

Procedure

1. In the Copy parameters (S6.3) subpage, find the *Up to keypad page (S6.3.2)*.
2. Push the Menu button Right.
3. To go to the edit mode, push the Menu button Right.

 *All param.* starts to blink.

4. To accept the selection, push the [enter] button.
5. Wait until *OK* shows on the display.

8.7.5.3 Downloading Parameters to Drive (Down From Keypad, S6.3.3)

Use this function to download 1 or all parameter groups from the control panel to an AC drive when the AC drive is stopped.

Procedure

1. In the Copy parameters (S6.3) subpage, find the *Down from keypad page (S6.3.3)*.
2. Push the Menu button Right.
3. To go to the edit mode, push the Menu button Right.
4. Use the Browser buttons to select 1 of these 3 options:
 - All parameters (*All param.*)
 - All parameters but the motor nominal value parameters (*All. no motor*)
 - Application parameters
5. To accept the selection, push the [enter] button.
6. Wait until *OK* shows on the display.

8.7.5.4 Activating or Deactivating the Automatic Parameter Back-up (P6.3.4)

Use these instructions to activate or deactivate the parameter back-up.

When the application is changed, the parameters in the parameter settings on page S6.3.1 are deleted. To copy parameters from one application to a different application, first upload them to the control panel.

Procedure

1. In the Copy parameters (S6.3) subpage, find the Automatic parameter back-up page (S6.3.4).
2. To go to the edit mode, push the Menu button Right.
3. There are 2 options:
 - To activate the Automatic parameter back-up, select *Yes* with the Browser buttons.
 - To deactivate the Automatic parameter back-up, select *No* with the Browser buttons.

When the Automatic parameter back-up is active, the control panel makes a copy of the parameters of the application. Each time a parameter is changed, the keypad back-up is automatically updated.

8.7.5.5 Comparing the Parameters

Use the Parameter comparison submenu (S6.4, *Param.Comparison*) to compare the actual parameter values to the values of the customized parameter sets and those uploaded to the control panel. The actual values can be compared to Set 1, Set 2, Factory Settings, and Keypad Set.

Procedure

1. In the Copy parameters (S6.3) subpage, find the Comparing parameters submenu with the Browser buttons.
2. Push the Menu button Right.

➡ The actual parameter values are first compared to those of the customized parameter Set 1. If no differences are found, 0 shows on the bottom line. If there are differences, the display shows the number of the differences (for example, P1->P5 = 5 different values).

3. To compare the values to a different set, use the Browser buttons.
4. To go to the page with the parameter values, push the Menu button Right.

➡ In the display that opens, check the values on different lines:

Illustration 38: Parameter Values in Parameter Comparison

A	Value of the selected set
B	Actual value

5. To go to the edit mode, push the Menu button Right.

➡ The actual value starts to blink.

6. To change the actual value, use the Browser buttons, or change the value digit by digit with the Menu button Right.

8.7.6 Security

8.7.6.1 Finding the Security Menu

The Security menu is password protected. Use it to handle passwords, start-up wizards, and multimonitoring items, and to lock parameters.

Procedure

1. To find the *Security* submenu, scroll down in the *System* menu until the location indication S6.5 shows on the first line of the display.
2. To go to the *Security* submenu from the *System* menu, push the Menu button Right.

8.7.6.2 Passwords

To prevent unauthorized changes in the application selection, use the Password function (S6.5.1). By default, the password is not active.

NOTICE

Keep the password in a safe location!

8.7.6.3 Setting a Password

Set a password to protect the application selection menu.

N O T I C E

Keep the password in a safe location! The password cannot be changed if a valid password is not available.

Procedure

1. In *Security* submenu, push the Menu button Right.
2. To go to the edit mode, push the Menu button Right.

 The display shows 0 that blinks.

3. There are 2 options to set a password: with the Browser buttons or by digits. The password can be a number between 1 and 65535.
 - With the Browser buttons: Push the Browser buttons Up and Down to find a number.
 - By digits: Push the Menu button Right. A second 0 shows on the display.
 - Push the Browser buttons to set digit on the right.
 - Push the Menu button Left, and set the digit on the left.
 - To add a third digit, push the Menu button Left. Set up to 5 digits with Menu and Browser buttons and set the digit for each one with the Browser buttons.
4. To accept the new password, push the [enter] button.

The password activates after the Timeout time (P6.6.3) (see [8.7.7.4 Setting the Timeout Time](#)).

8.7.6.4 Entering a Password

In a password-protected submenu, the display shows *Password?* Use these instructions to enter the password.

Procedure

1. When the display shows *Password?*, give the password with the Browser buttons.

8.7.6.5 Deactivating the Password Function

Use these instructions to deactivate the password protection for application selection menu.

Procedure

1. Find the *Password* (S6.5.1) in the *Security* menu with the Browser buttons.
2. To go to the edit mode, push the Menu button Right.
3. Set value 0 for the password.

8.7.6.6 Locking a Parameter

Use the Parameter lock function to prevent changes to the parameters. If the parameter lock is active, the text *locked* shows on the display when trying to edit a parameter value.

N O T I C E

This function does not prevent unauthorized changes of parameter values.

Procedure

1. In the *Security* menu (M6), find the Parameter lock (P6.5.2) with the Browser buttons.
2. To go to the edit mode, push the Menu button Right.
3. To change the parameter lock status, use the Browser buttons.
4. To accept the change, push the [enter] button.

8.7.6.7 Start-up Wizard (P6.5.3)

The start-up wizard helps in the commissioning of the AC drive. By default, the start-up wizard is active.

In the start-up wizard, this information is set:

- the language
- the application
- the values for a set of parameters that are same to all applications
- the values for a set of application-specific parameters.

The table lists the functions of the keypad buttons in the start-up wizard.

Action	Button
Accepting a value	[enter] button
Scrolling for options	Browser buttons Up and Down
Changing a value	Browser buttons Up and Down

8.7.6.8 Activating/Deactivating the Start-up Wizard

Use these instructions to activate or deactivate the Start-up Wizard function.

Procedure

1. In the *System* menu (M6), find the page P6.5.3.
2. To go to the edit mode, push the Menu button Right.
3. Select the action:
 - To activate the start-up wizard, select *Yes* with the Browser buttons.
 - To deactivate the start-up wizard, select *No* with the Browser buttons.
4. To accept the selection, push the [enter] button.

8.7.6.9 Enabling/Disabling the Change of Multimonitoring Items

Use Multimonitoring to monitor up to 3 actual values at the same time (see [8.2 Using the Monitoring Menu \(M1\)](#) and the chapter Monitored values in the Application Manual of your application).

Use these instructions to enable the change when changing the values that are monitored with other values.

Procedure

1. In the *Security* submenu, find Multimonitoring items page (P6.5.4, *Multimon. items*) with the Browser buttons.
2. To go to the edit mode, push the Menu button Right.

↩ *Change Enabled* starts to blink.

3. Use Browser buttons Up and Down to select *Change Enabled* or *Change Disabled*.
4. Accept the selection with the [enter] button.

8.7.7 Keypad Settings

8.7.7.1 Finding the Keypad Settings Menu

Use the Keypad settings submenu in the System menu for making changes in the control panel.

In the submenu, there are 5 pages (P#) that control the panel operation:

- *Default page* (P6.6.1)
- *Default page/Operating menu* (P6.6.2)
- *Timeout time* (P6.6.3)
- *Contrast adjustment* (P6.6.4)
- *Backlight time* (P6.6.5)

Procedure

1. In the *System* menu (M6), find the *Keypad settings* submenu (S6.6) with the Browser buttons.

8.7.7.2 Changing the Default Page

Use the Default page to set the location (page) to which the display automatically moves after the Timeout time or after the panel is set on.

For more information on the timeout time, see [8.7.7.4 Setting the Timeout Time](#).

If the Default Page value is 0, the function is not activated. When the Default page is not used, the control panel shows the page that was last showed on the display.

Procedure

1. In the *Keypad settings* submenu, find the *Default page* subpage (P6.6.1) with the Browser buttons.
2. To go to the edit mode, push the Menu button Right.
3. To change the number of the main menu, use the Browser buttons.
4. To edit the number of the submenu/page, push the Menu button Right. Change the number of the submenu/page with the Browser buttons.
5. To edit the third level page number, push the Menu button Right. Change the number of the third level page with the Browser buttons.
6. To accept the new default page value, push the [enter] button.

8.7.7.3 Default Page in the Operating Menu (P6.6.2)

Use this submenu to set the default page in the Operating menu. The display automatically moves to the set page after the Timeout time (see [8.7.7.4 Setting the Timeout Time](#)) or after the control panel is set on. For instructions, see [8.7.7.2 Changing the Default Page](#).

The Operating menu is only available in special applications.

8.7.7.4 Setting the Timeout Time

The Timeout time sets the time after which the control panel display goes back to the *Default page* (P6.6.1), see [8.7.7.2 Changing the Default Page](#).

If the Default page value is 0, the Timeout time setting has no effect.

Procedure

1. In the *Keypad settings* submenu, find the *Timeout time* subpage (P6.6.3) with the Browser buttons.
2. To go to the Edit mode, push the Menu button Right.
3. To set the timeout time, use the Browser buttons.
4. To accept the change, push the [enter] button.

8.7.7.5 Contrast Adjustment (P6.6.4)

If the display is not clear, adjust its contrast with the same procedure as the one for the timeout time setting, see [8.7.7.4 Setting the Timeout Time](#).

8.7.7.6 Backlight Time (P6.6.5)

It is possible to set the time that the backlight stays on until it goes off. Select a value between 1 and 65535 minutes or *Forever*. For instructions on how to change the value, see [8.7.7.4 Setting the Timeout Time](#).

8.7.8 Hardware Settings

8.7.8.1 Finding the Hardware Setting Menu

Use the Hardware settings submenu (*S6.7, HW settings*) in the *System* menu to control these functions of the hardware in the AC drive:

- Internal brake resistor connection, *InternBrakeRes*
- *Fan control*
- HMI acknowledge timeout, *HMI ACK timeout*
- *HMI retry*
- Sine filter
- Pre-charge mode.

Use a password to go the Hardware settings submenu, see [8.7.6.2 Passwords](#).

Procedure

1. To find the Hardware settings submenu, scroll down in the *System* menu until the location indication *S6.7* shows on the first line of the display.
2. To go to the Hardware settings submenu from the *System* menu, push the Menu button Right.

8.7.8.2 Setting the Internal Brake Resistor Connection

Use this function to tell the AC drive if the internal brake resistor is connected or not.

If the AC drive has an internal brake resistor, the default value of this parameter is *Connected*. We recommend changing this value to *Not conn.* if:

- it is necessary to install an external brake resistor to increase the braking capacity
- the internal brake resistor is disconnected for some reason.

The brake resistor is available as optional equipment for all sizes. It can be installed internally in enclosure sizes FR4 to FR6.

Procedure

1. In the Hardware settings submenu, find the Internal brake resistor connection (*P6.7.1*) subpage with the Browser buttons.
2. To go to the edit mode, push the Menu button Right.
3. To change the internal brake resistor status, use the Browser buttons.
4. To accept the change, push the [enter] button.

8.7.8.3 Fan Control

Use this function to control the cooling fan of the AC drive. There are 4 options to select from:

- *Continuous* (default setting). The fan is always on when the power is on.
- *Temperature*. The fan starts automatically when the heat sink temperature goes to 60 °C (140 °F) or when the AC drive operates. The fan stops about a minute after one of the following:
 - the heat sink temperature falls to 55 °C (131 °F)
 - the AC drive stops
 - the fan control value is changed from *Continuous* to *Temperature*
- *First start*. When power is on, the fan is in the stop state. When the AC drive gets the first start command, the fan starts.
- *Calc temp*. The fan function agrees to the calculated IGBT temperature:
 - If the IGBT temperature is more than 40 °C (104 °F), the fan starts.
 - If the IGBT temperature is below 30 °C (86 °F), the fan stops.

As the default temperature at power-up is 25 °C (77 °F), the fan does not start immediately.

For instructions, see [8.7.8.4 Changing the Fan Control Settings](#).

8.7.8.4 Changing the Fan Control Settings

Use these instructions to change the Fan Control Settings.

Procedure

1. In the Hardware settings submenu, find the *Fan control* settings (*P6.7.2*) with the Browser buttons.
2. To go to the edit mode, push the Menu button Right.

 The parameter value starts to blink.

3. To select the fan mode, use the Browser buttons.
4. To accept the change, push the [enter] button.

8.7.8.5 HMI Acknowledge Timeout (P6.7.3)

Use this function to change the timeout of the HMI acknowledgement time. Use this function when there is more delay in the RS232 transmission, for example, when internet connection is used for communication over longer distances.

If the AC drive is connected to the PC with a cable, do not change the default values of parameters P6.7.3 and P6.7.4 (200 and 5).

If the AC drive is connected to the PC with an internet connection and the messages are transferred with a delay, set the values for parameter P6.7.3 to agree these delays.

For instructions, see [8.7.8.6 Changing the HMI Acknowledge Timeout](#).

Example

For example, if the transfer delay between the AC drive and the PC is 600 ms, make these settings:

- Set the value of parameter P6.7.3 to 1200 ms (2 x 600, sending delay + receiving delay)
- Set the [Misc]-part of the file NCDrive.ini to agree with the settings:
 - Retries = 5
 - AckTimeOut = 1200
 - TimeOut = 6000

Do not use intervals shorter than the AckTimeOut-time in the NC-Drive monitoring.

8.7.8.6 Changing the HMI Acknowledge Timeout

Use these instructions to change the HMI Acknowledge Timeout.

Procedure

1. In the Hardware settings submenu, find the HMI acknowledgement time (*HMI ACK timeout*) with the Browser buttons.
2. To go to the edit mode, push the Menu button Right.
3. To change the acknowledgement time, use the Browser buttons.
4. To accept the change, push the [enter] button.

8.7.8.7 Changing the Number of Retries to Receive HMI Acknowledgement (P6.7.4)

Use this parameter to set the number of times the AC drive tries to receive acknowledgement if it does not receive it during the acknowledgement time (P6.7.3) or if the received acknowledgement is defective.

Procedure

1. In the Hardware settings submenu, find the Number of retries to receive HMI acknowledgement (*P6.7.4*) with the Browser buttons.
2. To go to the edit mode, push the Menu button Right. The value starts to blink.
3. To change the number of retries, use the Browser buttons.
4. To accept the change, push the [enter] button.

8.7.8.8 Sine Filter (P6.7.5)

When using an old motor or a motor that was not made to be used with an AC drive, it can be necessary to use a sine filter. A sine filter makes the sine form of the voltage better than a dU/dt filter.

If a sine filter is used in the AC drive, set this parameter to *Connected* to put it into operation.

8.7.8.9 Pre-charge Mode (P6.7.6)

For an FI9 or a larger inverter unit, select *Ext.ChSwitch* to control an external charge switch.

8.7.9 System Info

8.7.9.1 Finding the System Info Menu

The *System info* submenu (*S6.8*) contains information on the hardware, software, and operation of the AC drive.

Procedure

1. To find the *System info* submenu, scroll down in the *System* menu until the location indication *S6.8* shows on the first line of the display.
2. To go to the *System info* submenu from the *System* menu, push the Menu button Right.

8.7.9.2 Total Counters (S6.8.1)

The *Total counters* page (*S6.8.1*) has information on the AC drive operation times. The counters show the total number of MWh, operation days, and operation hours. The Total counters cannot be reset.

The Power On time counter (days and hours) always counts, when the AC power is on. The counter does not count when control unit runs on +24 V only.

Table 13: Total Counters

Page	Counter	Example
C6.8.1.1.	MWh counter	
C6.8.1.2.	Power On day counter	Value on display is 1.013. The drive has operated for 1 year and 13 days.
C6.8.1.3	Power On hour counter	Value on display is 7:05:16. The drive has operated for 7 hours 5 minutes and 16 s.

8.7.9.3 Trip Counters (S6.8.2)

The *Trip counters* page (S6.8.2) has information on resettable counters, that is, counters, for which the value can be set back to 0. The trip counters count only when the motor is in RUN state.

Table 14: Trip Counters

Page	Counter	Example
T6.8.2.1	MWh counter	–
T6.8.2.3	Operation day counter	Value on display is 1.013. The drive has operated for 1 year and 13 days.
T6.8.2.4	Operation hour counter	Value on display is 7:05:16. The drive has operated for 7 hours 5 minutes and 16 s.

8.7.9.4 Resetting the Trip Counters

Use these instructions to reset the trip counters.

Procedure

1. In the *System info* submenu, find the *Trip counters* page (6.8.2) with the Browser buttons.
2. To go to the Clear MWh counter page (6.8.2.2, *Clr MWh cnt*) or to the Clear Operation time counter page (6.8.2.5, *Clr Optime cnt*), use the Menu button Right.
3. To go to the edit mode, push the Menu button Right.
4. To select Reset, push Browser buttons Up and Down.
5. To accept the selection, push the [enter] button.
6. The display shows again *Not reset*.

8.7.9.5 Software (S6.8.3)

The Software information page includes information on the AC drive software.

Page	Content
6.8.3.1	Software package
6.8.3.2	System software version
6.8.3.3	Firmware interface
6.8.3.4	System load

8.7.9.6 Applications (S6.8.4)

The *Applications* submenu (S6.8.4) contains information on all applications on the AC drive.

Page	Content
6.8.4.#	Name of application
6.8.4.#.1	Application ID
6.8.4.#.2	Version
6.8.4.#.3	Firmware interface

8.7.9.7 Examining the Application Page

Use these instructions to examine the *Applications* pages.

Procedure

1. In the *System info* submenu, find the *Applications* page with the Browser buttons.
2. To go to the *Applications* page, push the Menu button Right.
3. To select the application, use the Browser buttons. There are as many pages as there are applications on the AC drive.
4. To go to the Information pages, use the Menu button Right.
5. To see the different pages, use the Browser buttons.

8.7.9.8 Hardware (S6.8.5)

The Hardware information page includes information on the AC drive hardware.

Page	Content
6.8.5.1	Power unit type code
6.8.5.2	Nominal voltage of the unit
6.8.5.3	Brake chopper
6.8.5.4	Brake resistor
6.8.5.5	Serial number

8.7.9.9 Checking the Status of an Option Board

The *Expander boards* pages give information about the basic and option boards connected to the control board. See [7.1 Control Unit Components](#) for more information on the boards.

For more information on the parameters of the option boards, see [8.8.1 Expander Board Menu](#).

Procedure

1. In the *System info* submenu, find the *Expander boards* page (6.8.6) with the Browser buttons.
2. To go to the *Expander boards* page, push the Menu button Right.
3. To select the board, use the Browser buttons.



If no board is connected to the slot, the display shows *no board*.

If a board is connected to a slot but there is no connection, the display shows *no conn..*

4. To see the status of the board, push the Menu button Right.
5. To see the program version of the board, push the Browser button Up or Down.

8.7.9.10 Debug Menu (S6.8.7)

The Debug menu is for advanced users and application designers. Speak to the factory to get instructions, if it is necessary.

8.8 Using the Expander Board Menu

8.8.1 Expander Board Menu

The *Expander board* menu, that is, the menu for option board information, allows to:

- see which option boards are connected to the control board
- find and edit the option board parameters.

Table 15: Option Board Parameters (Board OPTA1)

Page	Parameter	Min	Max	Default	Cust	Selections
P7.1.1.1	AI1 mode	1	5	3		1 = 0–20 mA 2 = 4–20 mA 3 = 0–10 V 4 = 2–10 V 5 = –10...+10 V
P7.1.1.2	AI2 mode	1	5	1		See P7.1.1.1
P7.1.1.3	AO1 mode	1	4	1		1 = 0–20 mA 2 = 4–20 mA 3 = 0–10 V 4 = 2–10 V

8.8.2 Examining the Connected Option Boards

Use these instructions to examine the connected option boards.

Procedure

1. To find the *Expander board* menu, scroll down in the main menu until the location indication *M7* shows on the first line of the display.
2. To go to the *Expander board* menu from the main menu, push the Menu button Right.
3. To examine the list of connected option boards, use the Browser buttons Up and Down.
4. To see the information on the option board, push the Menu button Right.

8.8.3 Finding the Option Board Parameters

Use these instructions to check the values of the option board parameters.

Procedure

1. Find the option board with the Browser and Menu buttons in the *Expander Board Menu*.
2. To see the information on the option board, push the Menu button Right. For instructions on how to examine the connected option boards, see [8.8.2 Examining the Connected Option Boards](#).
3. To scroll to the Parameters use the Browser buttons Up and Down.
4. To examine the parameter list, push the Menu button Right.
5. To scroll through the parameters, use the Browser buttons Up and Down.
6. To go to the edit mode, push the Menu button Right. For instructions on how to edit the parameter values, see [8.3.2 Selecting Values](#) and [8.3.3 Editing the Values Digit by Digit](#).

8.9 Further Control Panel Functions

The VACON[®]NX control panel has more application-related functions. See VACON[®]NX Application Package for more information.

9 Commissioning

9.1 Safety Checks before Starting the Commissioning

Before starting the commissioning, read these warnings.

⚠ D A N G E R ⚠

SHOCK HAZARD FROM INVERTER POWER UNIT COMPONENTS

The inverter power unit components are live when the inverter is connected to DC supply. A contact with this voltage can lead to death or serious injury.

- Do not touch the components of the power unit when the inverter is connected to DC supply. Before connecting the inverter to DC supply, make sure that the covers of the inverter are closed.

⚠ D A N G E R ⚠

SHOCK HAZARD FROM INVERTER TERMINALS

The motor terminals U, V, W, the brake resistor terminals, or the DC terminals are live when the inverter is connected to DC supply, also when the motor does not operate. A contact with this voltage can lead to death or serious injury.

- Do not touch the motor terminals U, V, W, the brake resistor terminals, or the DC terminals when the inverter is connected to DC supply. Before connecting the inverter to DC supply, make sure that the covers of the inverter are closed.

⚠ D A N G E R ⚠

SHOCK HAZARD FROM DC LINK OR EXTERNAL SOURCE

The terminal connections and the components of the drive can be live 5 minutes after the inverter is disconnected from the DC supply and the motor has stopped. Also the load side of the inverter can generate voltage. A contact with this voltage can lead to death or serious injury.

- Before doing electrical work on the inverter:
Disconnect the inverter from the DC supply and make sure that the motor has stopped.
Lock out and tag out the power source to the inverter.
Make sure that no external source generates unintended voltage during work.
Wait 5 minutes before opening the cabinet door or the cover of the inverter.
Use a measuring device to make sure that there is no voltage.

⚠ W A R N I N G ⚠

SHOCK HAZARD FROM INVERTER CONTROL TERMINALS

The control terminals can have a dangerous voltage also when the drive is disconnected from DC supply. A contact with this voltage can lead to injury.

- Make sure that there is no voltage in the control terminals before touching the control terminals.

⚠ C A U T I O N ⚠

BURNING HAZARD FROM HOT SURFACES

The surface of the side of the AC drive FR8/FI8 is hot.

- Do not touch the side of the AC drive FR8/FI8 with hands when it operates.

⚠ C A U T I O N ⚠

FIRE HAZARD FROM HOT SURFACES

When the AC drive FR6/FI6 operates, the rear surface of the drive is hot, and can cause fire on the surface it is installed on.

- Do not install the AC drive FR6/FI6 on a surface that is not fireproof.

9.2 Commissioning the Inverter

Follow these instructions to commission the inverter.

Read the safety instructions in [2.2 Danger and Warnings](#) and [9.1 Safety Checks before Starting the Commissioning](#), and obey them.

Procedure

1. Make sure that the motor is installed correctly.
2. Make sure that the motor is not connected to mains.
3. Make sure that the inverter and the motor are grounded.
4. Make sure to select the DC supply cable, the brake cable, and the motor cable correctly.

For information on cable selections, see:

- [6.1.3 Cable Selection and Dimensioning, 6.1.4 Cable Selection and Dimensioning, North America](#) and related tables
- [6.1 Cable Connections](#)
- [6.3 EMC-compliant Installation](#)

5. Make sure that the control cables are as far as possible from the power cables. See [6.5.1 Additional Instructions for Cable Installation](#)
6. Make sure that the shields of the shielded cables are connected to a grounding terminal that is identified with the grounding symbol.
7. Do a check of the tightening torques of all the terminals.
8. Make sure that no power correction capacitors are connected to the motor cable.
9. Make sure that the cables do not touch the electrical components of the inverter.
10. Make sure that the common input +24 V is connected to an external power source and the ground of the digital input is connected to ground of the control terminal.
11. Do a check of the quality and quantity of the cooling air.

For further information on cooling requirements, see:

- [5.2.1 General Cooling Requirements](#)
- [5.2.2 Cooling of FI4 to FI8](#)
- [12.8 Technical Data](#)

12. Make sure that there is no condensation on the surfaces of the inverter.
13. Make sure that there are no unwanted objects in the installation space.
14. Before connecting the inverter to DC supply, do a check of the installation and the condition of all the fuses (see [12.3 Cable and Fuse Sizes](#)) and other protective devices.

9.3 Measuring the Cable and Motor Insulation

Do these checks if necessary.

- The insulation checks of the motor cable, see [9.3.1 Insulation Checks of the Motor Cable](#)
- The insulation checks of the DC supply cable, see [9.3.2 Insulation Checks of the DC Supply Cable](#)
- The insulation checks of the motor, see [9.3.3 Insulation Checks of the Motor](#)

9.3.1 Insulation Checks of the Motor Cable

Use these instructions to check the insulation of the motor cable.

Procedure

1. Disconnect the motor cable from the terminals U, V, and W and from the motor.
2. Measure the insulation resistance of the motor cable between phase conductors 1 and 2, between phase conductors 1 and 3, and between phase conductors 2 and 3.
3. Measure the insulation resistance between each phase conductor and the grounding conductor.
4. The insulation resistance must be >1 MΩ at the ambient temperature of 20 °C (68 °F).

9.3.2 Insulation Checks of the DC Supply Cable

Use these instructions to check the insulation of the DC supply cable.

Procedure

1. Disconnect the DC supply cable from terminals B- and B+ of the inverter and from DC supply.

2. Measure the insulation resistance between each phase conductor and the grounding conductor.
3. The insulation resistance must be $>1\text{ M}\Omega$ at the ambient temperature of $20\text{ }^{\circ}\text{C}$ ($68\text{ }^{\circ}\text{F}$).

9.3.3 Insulation Checks of the Motor

Use these instructions to check the insulation of the motor.

N O T I C E

Obey the instructions of the motor manufacturer.

Procedure

1. Disconnect the motor cable from the motor.
2. Open the bridging connections in the motor connection box.
3. Measure the insulation resistance of each motor winding. The voltage must be the same or higher than the motor nominal voltage, but at least 1000 V.
4. The insulation resistance must be $>1\text{ M}\Omega$ at the ambient temperature of $20\text{ }^{\circ}\text{C}$ ($68\text{ }^{\circ}\text{F}$).
5. Connect the motor cables to the motor.
6. Do the final insulation check on the drive side. Put all phases together and measure to the ground.
7. Connect the motor cables to the drive.

9.4 Checks after Commissioning

9.4.1 Testing the Inverter after Commissioning

Before starting the motor, do these checks.

- Before the tests, make sure that it is safe to do each test.
- Make sure that the other workers near know about the tests.

Procedure

1. Make sure that all the START and STOP switches that are connected to the control terminals are in the STOP position.
2. Make sure that the motor can be started safely.
3. Set the parameters of group 1 (see VACON® All in One Application Manual) to agree with the requirements of the used application. To find the necessary values for the parameters, see the motor nameplate.

Set these parameters at a minimum:

Motor nominal voltage

Motor nominal frequency

Motor nominal speed

Motor nominal current

4. Set the maximum frequency reference (that is, the maximum speed of the motor) to agree with the motor and the device that is connected to the motor.
5. Do the following tests in this order:
 - a. RUN test without the load, see [9.4.2 RUN Test without Load](#)
 - b. Start-up test, see [9.4.3 Start-up Test](#)

9.4.2 RUN Test without Load

Do either Test A or Test B.

- Test A: Controls from the control terminals
- Test B: Control from the control panel

9.4.3 Start-up Test

Do the start-up tests without the load, if possible. If it is not possible, make sure that it is safe to do each test before doing it. Make sure that the other workers near know about the tests.

Procedure

1. Switch off the DC supply voltage and wait until the inverter has stopped as advised in [9.1 Safety Checks before Starting the Commissioning](#).
2. Connect the motor cable to the motor and to the motor terminals of the inverter.
3. Make sure that all Start/Stop switches are in Stop positions.
4. Turn the supply voltage switch ON.
5. Do again the Run test A or B, see [9.4.2 RUN Test without Load](#).
6. If the motor was not connected in the start-up test, connect the motor to the process.
7. Do again the Run test A or B, see [9.4.2 RUN Test without Load](#).

9.4.4 Motor Run Checklist

Do these checks before starting the motor.

Procedure

1. Check that the motor is mounted properly and ensure that the machine connected to the motor allows the motor to be started.
2. Set the maximum frequency reference (that is, the maximum speed of the motor) according to the motor and the device that is connected to the motor.
3. Before reversing the motor, make sure it can be done safely.
4. Make sure that no power correction capacitors are connected to the motor cable.
5. Make sure that the motor terminals are not connected mains potential.

10 Maintenance

10.1 Preventive Maintenance Recommendations

Generally, all technical equipment, including Danfoss AC Drives need a minimum level of preventive maintenance. Regular maintenance is recommended to ensure trouble-free operation and long life of the drive. It is also recommended, as a good service practice to record a maintenance log with counter values, date, and time describing the maintenance and service actions.

Danfoss recommends the following inspections and service intervals for VACON[®]NXP family drive/system.

NOTE: The service schedule for part replacements may vary depending on operation conditions. Under specific conditions, the combination of stressful operating and environment conditions work together to significantly reduce the lifetime of the components. These conditions can include, for example, extreme temperature, dust, high humidity, hours of use, corrosive environment, and loading.

For operation in stressful conditions, Danfoss offers the DrivePro[®] Preventive Maintenance service. DrivePro[®] services extend the lifetime and increase the performance of the product with scheduled maintenance including customized part replacements. DrivePro[®] services are tailored to your application and operating conditions.

Table 16: Maintenance Schedule for Air-cooled Drives

Component	Inspection interval ⁽¹⁾	Service schedule ⁽²⁾	Preventive maintenance actions
Installation			
Visual drive inspection	1 year	–	Check for the unusual, for example, for signs of overheating, aging, corrosion, and for dusty and damaged components.
Auxiliary equipment	1 year	According to manufacturer recommendations	Inspect equipment, switchgear, relays, disconnects or fuses/circuit breakers. Examine the operation and condition for possible causes of operational faults or defects. The continuity check on fuses is performed by trained service personnel.
EMC consideration	1 year	–	Inspect the installation wiring regarding the electromagnetic capability and the separation distance between control wiring and power cables.
Cable routing	1 year	–	Check for parallel routing of motor cables, mains wiring, and signal wiring. Parallel routing must be avoided. Avoid routing cables through free air without support. Check for aging and wearing of the cable insulation.
Control wiring	1 year	–	Check for tightness, damaged or crimped wires or ribbon wires. The connections should be terminated correctly with solid crimped ends. The use of screened cables and earthed EMC plate, or a twisted pair is recommended.
Proper clearances	1 year	–	Check that the required external clearances for proper airflow for cooling are followed according to the frame designation and drive type of the drive. For clearances, refer to the local design regulations.
Seals condition	1 year	–	Check that the seals of the enclosure, the covers, and the cabinet doors are in good condition.
Corrosive environments	1 year	–	Conductive dust and aggressive gases, such as sulphide, chloride, salt mist, and so on, can damage the electrical and mechanical components. Air filters will not remove airborne corrosive chemicals. Act based on findings.
Drive			
Programming	1 year	–	Check that the AC drive parameter settings are correct according to the motor, drive application, and I/O configuration. Only trained service personnel may perform this action.
Control panel	1 year	–	Check that the display pixels are intact. Check the event log for warnings, alarms, and faults. Repetitive events are a sign of potential issues. Contact your local service center.

Component	Inspection interval ⁽¹⁾	Service schedule ⁽²⁾	Preventive maintenance actions
Drive Cooling capacity	1 year	–	Check for blockages or constrictions in the air passages of the cooling channel. The heat sinks must be free of dust and condensation.
Capacitors, DC link	1 year	8–15+ years	The expected lifetime of the capacitors is dependent on the loading profile of the application and the environmental temperature. For applications with heavy loads in demanding environments or high ripple current, replace electrolytic capacitors every 8 years. If within specification of the drive type, replace every 10–15+ years. Only trained service personnel may perform this action.
Cleaning and Filters	1 year	–	The interior of the enclosure should be cleaned annually, and more frequently if necessary. The level of dust in the filter or inside the enclosure is an indicator for when the next cleaning or filter replacement is required.
Fans	1 year	5–10 years	Inspect the condition and operational status of all cooling fans. With the power off, the fan axis should feel tight, and spinning the fan with a finger, the rotation should be almost silent and not have abnormal rotation resistance. When in RUN mode, fan vibration, excessive or strange noise is a sign of the bearings wearing, and the fan should be replaced.
Grounding	1 year	–	The drive system requires a dedicated ground wire connecting the drive, the output filter, and the motor to the building ground. Check that the ground connections are tight and free of paint or oxidation. Daisy-chain connections are not allowed. Braided straps are recommended if applicable.
PCB	1 year	10–12 years	Visually inspect the PCBs for signs of damage or degrading due to aging, corrosive environments, dust, or environments with high temperatures. Only trained service personnel may perform the inspection and service action.
Power cables and wiring	1 year	–	Check for loose connections, aging, insulation condition, and proper torque to the drive connections. Check for proper rating of fuses and continuity check. Observe if there are any signs of operation in a demanding environment. For example, discoloration of the fuse housing may be a sign of condensation or high temperatures.
Vibration	1 year	–	Check for abnormal vibration or noise coming from the drive to ensure that the environment is stable for electronic components.
Insulator gaskets	1 year	10–15 years	Inspect the insulators for signs of degradation due to high temperature and aging. Replacement is based on findings or done at the same time as DC capacitor replacement. Only trained service personnel may perform this action.
Spare Parts			
Spare parts	1 year	2 years	Stock spares in their original boxes in a dry and clean environment. Avoid hot storage areas. Electrolytic capacitors require reforming as stated in the service schedule. The reforming is performed by trained service personnel. See 10.2 Reforming the Capacitors .
Exchange units and units stored for long periods before commissioning	1 year	2 years	Visually inspect for signs of damage, water, high humidity, corrosion, and dust within the visual field of view without disassembly. The exchange units with mounted electrolytic capacitors require reforming as stated in the service schedule. The reforming is performed by trained service personnel. See 10.2 Reforming the Capacitors .

¹ Defined as the time after the commissioning/start-up or the time from the previous inspection.

² Defined as the time after the commissioning/start-up or the time from the previous service schedule actions.

10.2 Reforming the Capacitors

The electrolytic capacitors in the DC link rely on a chemical process to provide the insulator between the two metal plates. This process can degrade over a period of years when the drive has been non-operational (stocked). The result is that the working voltage of the DC link gradually falls.

The correct course of action is to ensure that the insulation layer of the capacitor is 'reformed' by the application of a limited current using a DC supply. Current limiting ensures that the heat generated within the capacitor is kept at a sufficiently low level to prevent any damage.

⚠ D A N G E R ⚠

SHOCK HAZARD FROM CAPACITORS

The capacitors can be charged even when disconnected. Contact with this voltage can lead to death or serious injury.

- If the AC drive or spare capacitors are intended to be stocked, discharge the capacitors before storage. Use a measuring device to make sure that there is no voltage. If in doubt, contact your Danfoss Drives representative.

Case 1: AC drive which has been non-operational or stocked for over 2 years.

1. Connect the DC supply to L1 and L2 or the B+/B terminals (DC+ to B+, DC- to B-) of the DC link or directly to the capacitor terminals. In the NX AC drives with no B+/B- terminals (FR8–FR9/FI8–FI9), connect the DC supply between 2 input phases (L1 and L2).
2. Set the current limit maximum to 800 mA.
3. Slowly increase the DC voltage to the nominal DC voltage level of the AC drive ($1.35 \times U_n$ AC).
4. Start to reform the capacitors.

The time of reforming depends on the time of storage. See [Illustration 39](#).

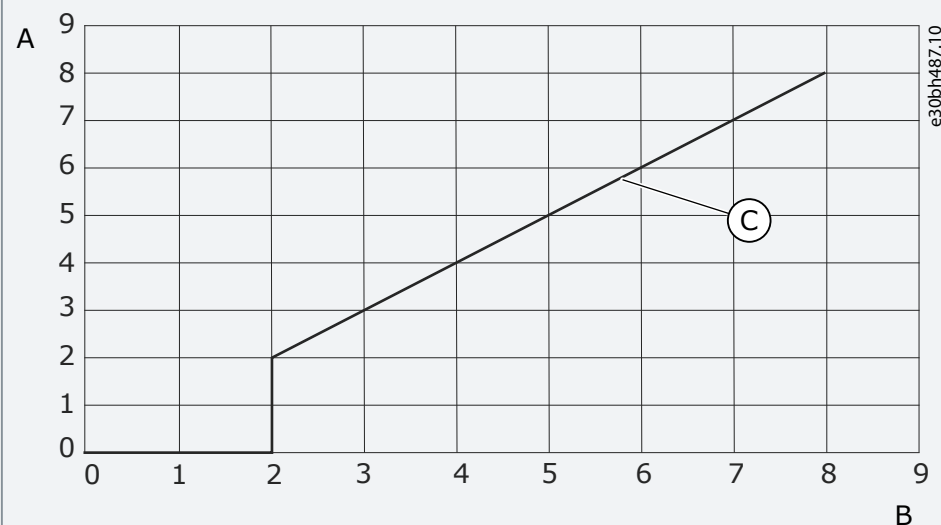

Illustration 39: Storage Time and Reforming Time

A	Storage time (years)	C	Reforming time
B	Reforming time (hours)		

5. After the reforming operation is done, discharge the capacitors.

Case 2: Spare capacitor which has been stocked for over 2 years.

1. Connect the DC supply to DC+/DC- terminals.
2. Set the current limit maximum to 800 mA.
3. Slowly increase the DC voltage to the capacitor nominal voltage level. See information from component or service documentation.
4. Start to reform the capacitors.

The time of reforming depends on the time of storage. See [Illustration 39](#).

5. After the reforming operation is done, discharge the capacitors.

11 Fault Tracing

11.1 General Information on Fault Tracing

When the control diagnostics of the AC drive find an unusual condition in the operation of the drive, the drive shows this information:

- This information shows on the display (see [8.5.1 Finding the Active Faults Menu](#)):
 - the location indication F1
 - the fault code, see the Faults and Alarms section
For option board related fault codes, see the option board manual.
 - a short description of the fault
 - the fault type symbol, see [Table 17](#)
 - the *FAULT* or *ALARM* symbol
- The red LED on the control panel starts to blink (only when a fault shows).

If many faults show at the same time, examine the list of active faults with the Browser buttons.

In the VACON®NX AC drives, there are 4 different types of faults.

Table 17: Fault Types

Fault type symbol	Description
A (Alarm)	The type A fault (Alarm) tells about unusual operation on the drive. It does not stop the drive. The 'A fault' stays in the display for about 30 s.
F (Fault)	The type 'F fault' stops the drive. To start the drive again, find a solution to the problem.
AR (Fault Autoreset)	The type 'AR fault' stops the drive. The fault is reset automatically and the drive tries to start the motor again. If it cannot start the motor again, a fault trip (see FT, Fault Trip) shows.
FT (Fault Trip)	If the drive cannot start the motor after an AR fault, an FT fault shows. The type 'FT fault' stops the AC drive.

The fault stays active until it is reset, see [11.2 Resetting a Fault](#). The memory of active faults can keep the maximum of 10 faults in the order in which they were shown.

Reset the fault with the [reset] button on the control panel, or through the control terminal, fieldbus, or the PC tool. The faults stay in the Fault history.

Before asking help from the distributor or the factory because of unusual operation, prepare some data. Write down all the texts on the display, the fault code, the source information, the Active Faults list, and the Fault History.

11.2 Resetting a Fault

The fault stays active until it is reset. Reset the fault using these instructions.

Procedure

1. Remove the external Start signal before resetting the fault to prevent that the drive starts again without a note.
2. There are 2 options to reset a fault:
 - Push the [reset] button on the control panel for 2 s.
 - Use a reset signal from the I/O terminal or fieldbus.

The display goes back to the same state it was before the fault.

11.3 Creating Service Info File

Use these instructions to create a service info file in VACON®NCDrive PC tool to help to troubleshoot in a fault situation.

Make sure the VACON®NCDrive PC tool is installed on the computer. To install it, go to our website <http://drives.danfoss.com/downloads/portal/>.

Procedure

1. Open the VACON[®]NCDrive.
2. Go to *File* and select *Service Info...*

 The service information file opens.

3. Save the service info file on the computer.

12 Specifications

12.1 Weights of the Inverter

Enclosure size	Weight, IP21/IP54 [kg]	Weight, UL Type 1/Type 12 [lb.]
F14	5.0	11.0
F16	16	32.3
F17	29.0	63.9
F18	48.0	105.8

12.2 Dimensions

For dimension information, see the following topics:

- [12.2.1 Dimensions for F14–F18](#)
- [12.2.2 Dimensions for Flange Mounting, F14–F16](#)
- [12.2.3 Dimensions for Flange Mounting, F17–F18](#)

12.2.1 Dimensions for FI4–FI8

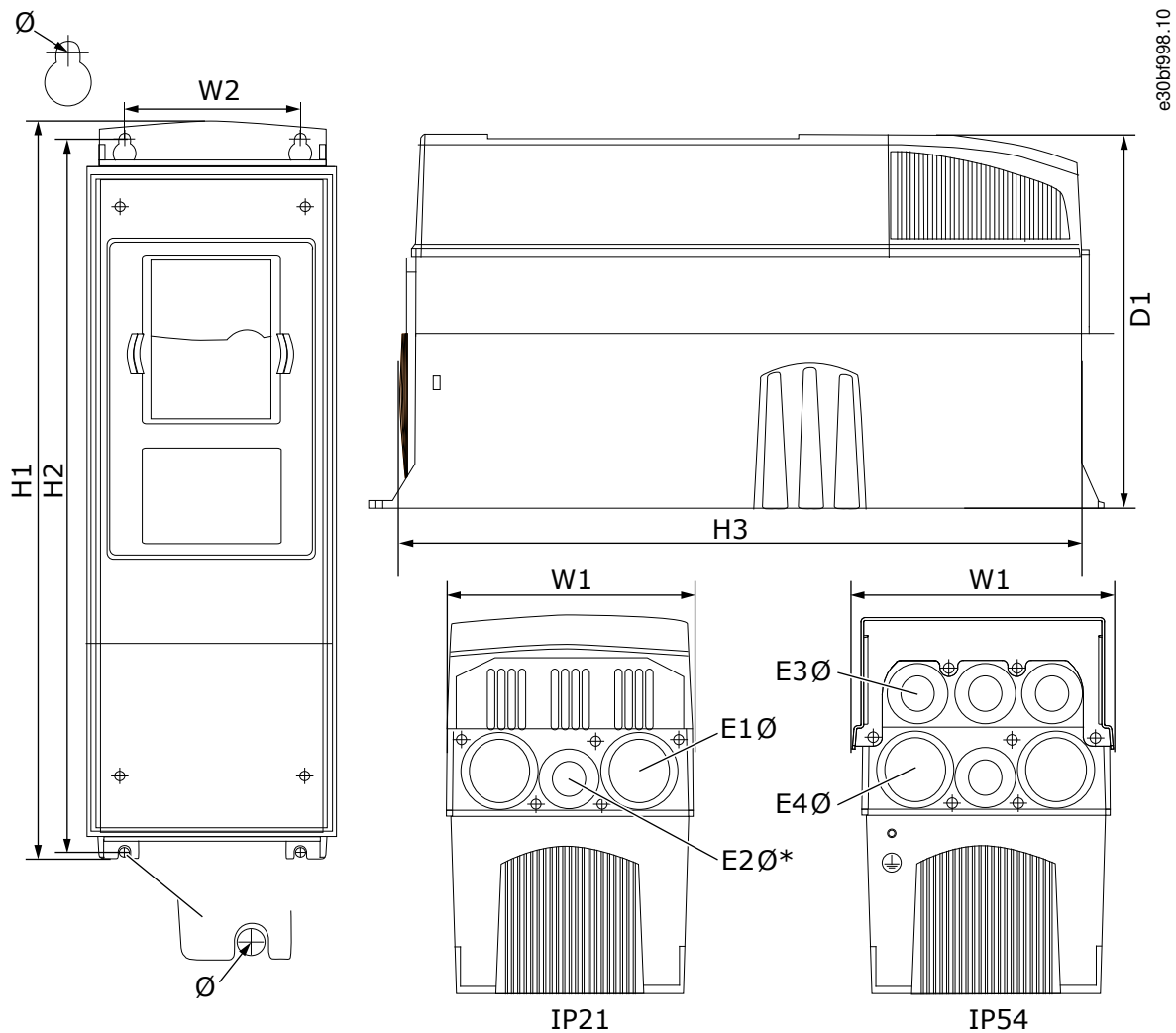

Illustration 40: Dimensions of the VACON[®]NX Inverters, FI4–FI8

Table 18: Dimensions in mm (in inch) of the VACON[®]NX Inverters, FI4–FI8

Drive type	W1	W2	H1	H2	H3	D1	Ø	E1Ø	E3Ø	E4Ø ⁽¹⁾
0004 2–0012 5	128 (5.04)	100 (3.94)	327 (12.87)	313 (12.32)	292 (11.5)	190 (7.48)	7 (0.27)	3 x 28.3 (3 x 1.11)	6 x 28.3 (6 x 1.11)	– (–)
0016 5–0045 5 0004 6–0034 6	195 (7.68)	148 (5.83)	558 (21.97)	541 (21.3)	519 (20.43)	237 (9.33)	9 (0.35)	3 x 37 (3 x 1.46)	3 x 37 (3 x 1.46)	3 x 28.3 (3 x 1.11)
0061 5–0105 5 0041 6–0052 6	237 (9.33)	190 (7.48)	630 (24.80)	614 (24.17)	591 (23.27)	237 (9.33)	9 (0.35)	3 x 37 (3 x 1.46)	3 x 37 (3 x 1.46)	3 x 28.3 (3 x 1.11)
0140 5 0062 6–0100 6	285 (11.22)	255 (10.04)	755 (29.72)	732 (28.81)	721 (28.39)	312 (12.28)	9 (0.35)	3 x 59 (3 x)		

¹ FI6 only

12.2.2 Dimensions for Flange Mounting, FI4–FI6

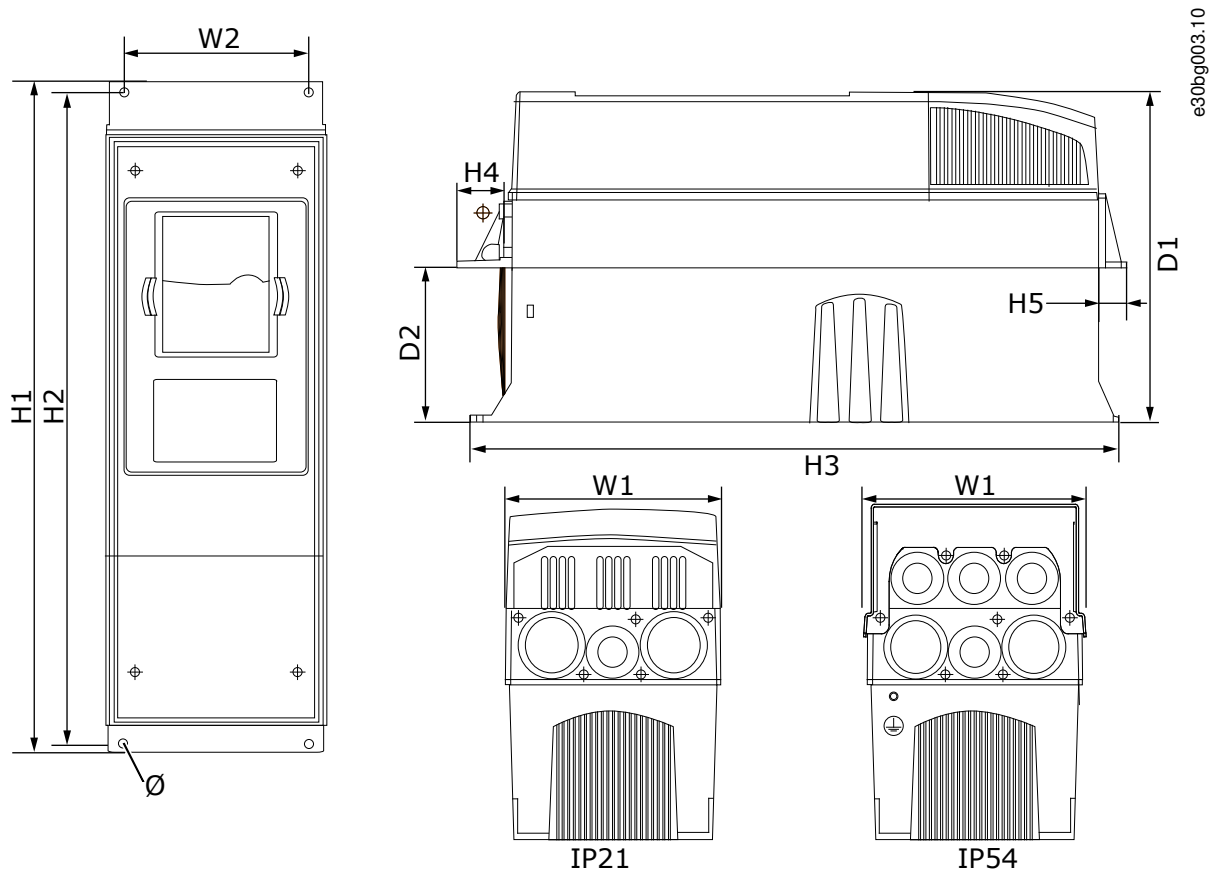

Illustration 41: Dimensions of the VACON[®]NX Inverters with Flange, FI4–FI6

Table 19: Dimensions in mm (in inch) of the VACON[®]NX Inverters with Flange, FI4–FI6

Drive type	W1	W2	H1	H2	H3	H4	H5	D1	D2	Ø
0004 5–0012 5	128 (5.03)	113 (4.45)	337 (13.27)	325 (12.8)	327 (12.9)	30 (1.18)	22 (0.87)	190 (7.48)	77 (3.03)	7 (0.27)
0016 5–0045 5 0004 6–0034 6	195 (7.68)	170 (6.69)	560 (22.05)	549 (21.61)	558 (22)	30 (1.18)	20 (0.79)	237 (9.33)	106 (4.17)	6.5 (0.26)

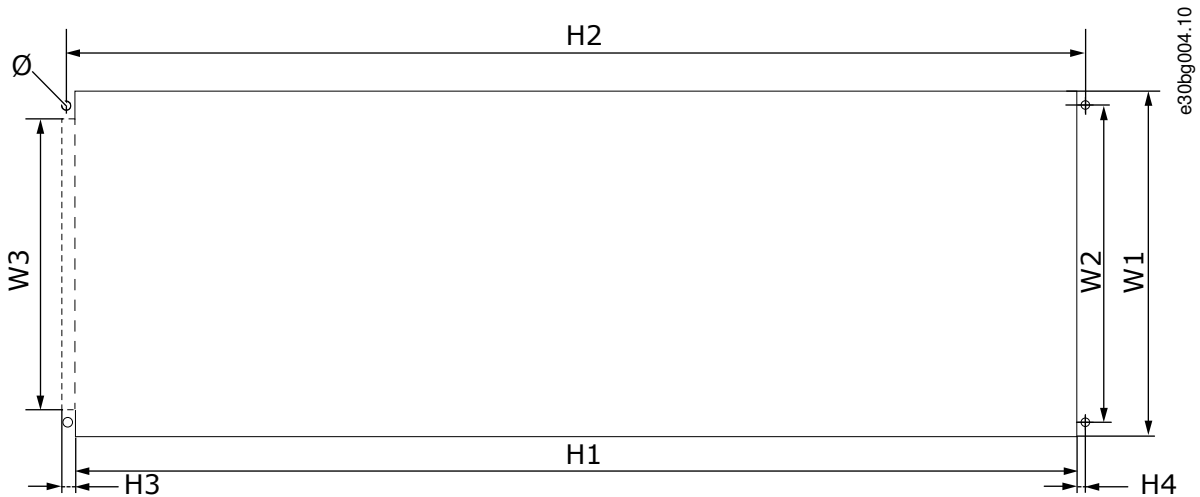

Illustration 42: The Dimensions of the Opening and Drive Outline with Flange, FI4 to FI6

Table 20: The Dimensions in mm (in inch) of the Opening and Drive Outline with Flange, FI4 to FI6

Drive type	W1	W2	W3	H1	H2	H3	H4	Ø
0004 5-0012 5	123 (4.84)	113 (4.45)	- (-)	315 (12.40)	325 (12.8)	- (-)	5 (0.20)	6.5 (0.26)
0016 5-0045 5 0004 6-0034 6	185 (7.28)	170 (6.69)	157 (6.18)	539 (21.22)	549 (21.61)	7 (0.27)	5 (0.20)	6.5 (0.26)

12.2.3 Dimensions for Flange Mounting, FI7-FI8

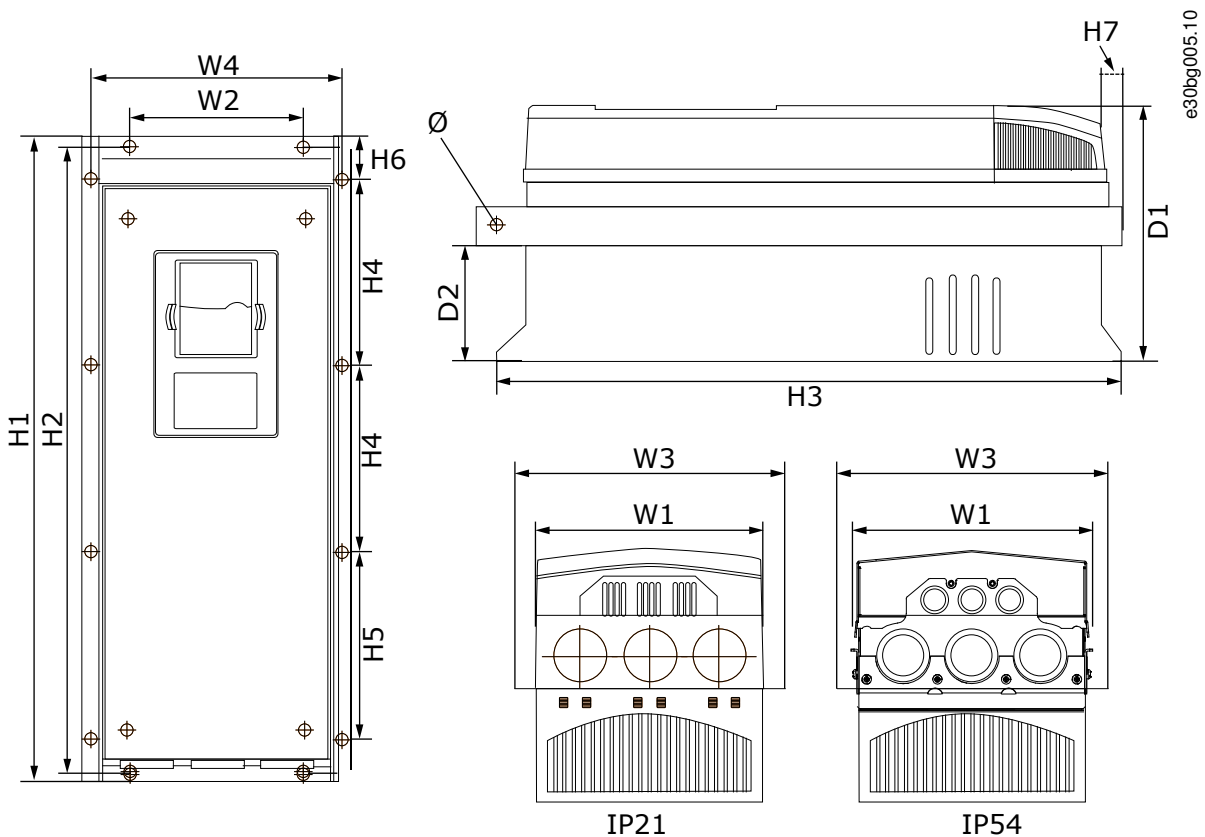

Illustration 43: Dimensions of the VACON® NX Inverters with Flange, FI7 and FI8

Table 21: Dimensions in mm (in inch) of the VACON®NX Inverters with Flange, FI7 and FI8, part 1

Drive type	W1	W2	W3	W4	D1	D2	Ø
0061 5–0105 5 0041 6–0052 6	237 (9.33)	175 (6.89)	270 (10.63)	253 (9.96)	257 (10.12)	117 (4.61)	5.5 (0.22)
0140 5 0062 6–0100 6	285 (29.72)	– (–)	355 (13.98)	330 (12.99)	288 (11.34)	110 (4.33)	9 (0.35)

Table 22: Dimensions in mm (in inch) of the VACON®NX Inverters, FI7 and FI8, part 2

Drive type	H1	H2	H3	H4	H5	H6	H7
0061 5–0105 5 0041 6–0052 6	652 (25.67)	632 (24.88)	630 (24.80)	188.5 (7.42)	188.5 (7.42)	23 (0.91)	20 (0.79)
0140 5 0062 6–0100 6	755 (29.72)	– (–)	745 (29.33)	258 (10.16)	265 (10.43)	43 (1.69)	57 (2.24)

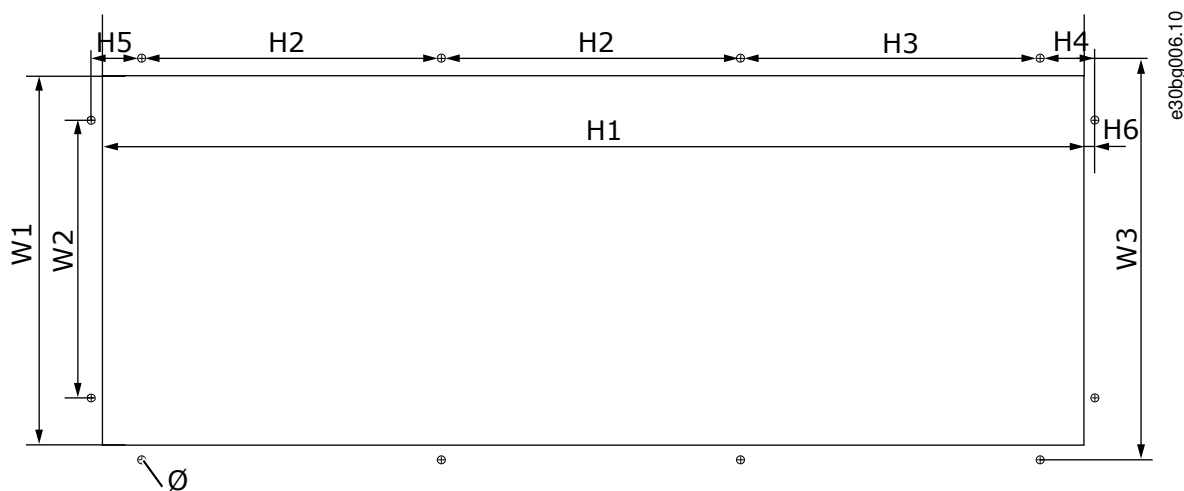

Illustration 44: Dimensions of the Opening and Drive Outline with Flange, FI7

Table 23: Dimensions in mm (in inch) of the Opening and Drive Outline with Flange, FI7

Drive type	W1	W2	W3	H1	H2	H3	H4	H5	H6	Ø
0061 5–0105 5 0041 6–0052 6	233 (9.17)	175 (6.89)	253 (9.96)	619 (24.4)	188.5 (7.42)	188.5 (7.42)	34.5 (1.36)	32 (1.26)	7 (0.28)	5.5 (0.22)

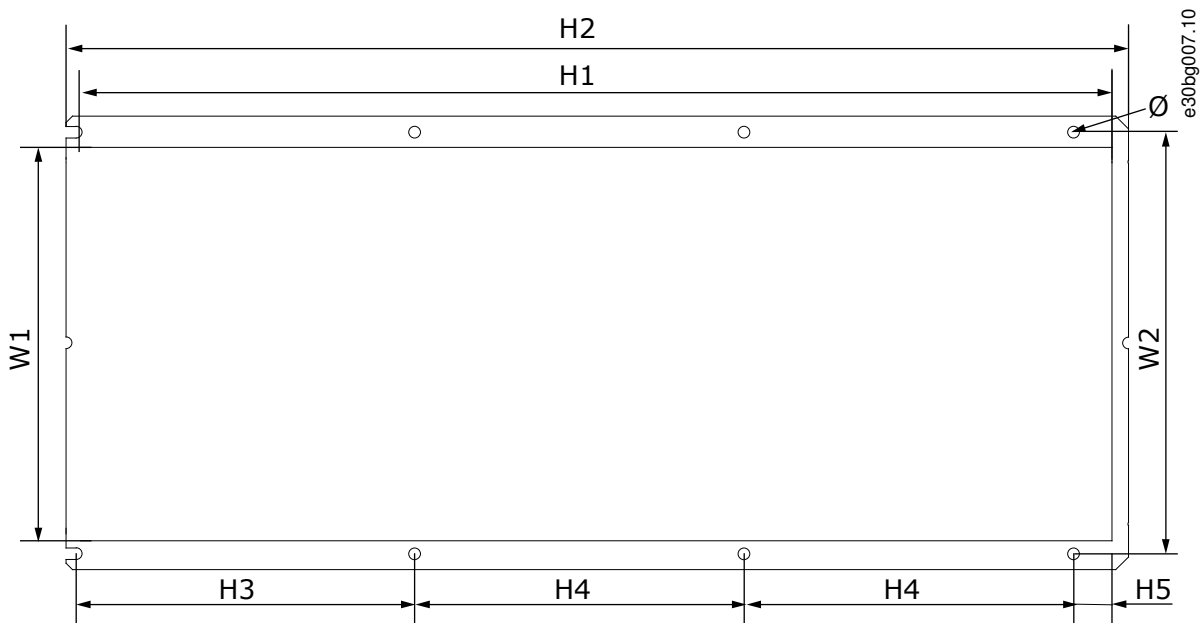

Illustration 45: Dimensions of the Opening and Drive Outline with Flange, FI8

Table 24: Dimensions in mm (in inch) of the Opening and Drive Outline with Flange, FI8

Drive type	W1	W2	H1	H2	H3	H4	H5	Ø
0140 5 0062 6-0100 6	301 (11.85)	330 (12.99)	810 (31.89)	832 (32.76)	265 (10.43)	258 (10.16)	33 (1.30)	9 (0.35)

12.3 Cable and Fuse Sizes

For cable and fuse size information, see the following topics:

- [12.3.1 Fuse Sizes for 465–800 V DC \(380–500 V AC\)](#)
- [12.3.2 Fuse Sizes for 640–1100 V DC \(525–690 V AC\)](#)
- [12.3.3 Cable Sizes for 465–800 V DC \(380–500 V AC\)](#)
- [12.3.4 Cable Sizes for 640–1100 V DC \(525–690 V AC\)](#)

12.3.1 Fuse Sizes for 465–800 V DC (380–500 V AC)

Table 25: Fuse Sizes for 465–800 V DC (380–500 V AC)

Enclosure size	Drive type	I ^L [A]	Bussmann aR fuse type	Fuse size	Fuse U ⁿ [V]	Fuse I ⁿ [A]	Number of fuses
FI4	NXI_0004 5	4.3	170M1560	000	690	20	2
	NXI_0009 5	9	170M1562	000	690	32	2
	NXI_0012 5	12	170M1562	000	690	32	2
FI6	NXI_0016 5	16	170M1565	000	690	63	2
	NXI_0022 5	22	170M1565	000	690	63	2
	NXI_0031 5	31	170M1565	000	690	63	2
	NXI_0038 5	38	170M1567	000	690	100	2
	NXI_0045 5	45	170M1567	000	690	100	2
FI7	NXI_0061 5	61	170M1568	000	690	125	2

Enclosure size	Drive type	I ^L [A]	Bussmann aR fuse type	Fuse size	Fuse U ⁿ [V]	Fuse I ⁿ [A]	Number of fuses
	NXI_0072 5	72	170M1570	000	690	200	2
	NXI_0087 5	87	170M1570	000	690	200	2
	NXI_0105 5	105	170M1571	000	690	250	2
FI8	NXI_0140	140	170M3819	1	690	400	2

12.3.2 Fuse Sizes for 640–1100 V DC (525–690 V AC)

Table 26: Fuse Sizes for 640–1100 V DC (525–690 V AC)

Enclosure size	Type	I ^L [A]	Bussman aR fuse type	Fuse size	Fuse U ⁿ [V]	Fuse I ⁿ [A]	No. of fuses
FI6	NXI_0004 6	4.3	170M2673	00	1000	20	2
	NXI_0005 6	5.5	170M2673	00	1000	20	2
	NXI_0007 6	7.5	170M2673	00	1000	20	2
	NXI_0010 6	10	170M2673	00	1000	20	2
	NXI_0013 6	13.5	170M2679	00	1000	63	2
	NXI_0018 6	18	170M2679	00	1000	63	2
	NXI_0022 6	22	170M2679	00	1000	63	2
	NXI_0027 6	27	170M2679	00	1000	63	2
	NXI_0034 6	34	170M2680	00	1000	160	2
FI7	NXI_0041 6	41	170M2683	00	1000	160	2
	NXI_0052 6	52	170M2683	00	1000	160	2
FI8	NXI_0062 6	62	170M4199	1SHT	1250	400	2
	NXI_0080 6	80	170M4199	1SHT	1250	400	2
	NXI_0100 6	100	170M4199	1SHT	1250	400	2

12.3.3 Cable Sizes for 465–800 V DC (380–500 V AC)

Table 27: Cable Sizes for 465–800 V DC (380–500 V AC)

Enclosure size	Drive type	I _L [A]	Supply cable Cu [mm ²]	Motor cable Cu [mm ²]	Main terminal cable [mm ²]	Earth terminal cable [mm ²]
FI4	NXI_0004 5–0009 5	3–9	2*1.5	3*1.5+1.5	1–4	1–2.5
	NXI_0012 5	12	2*2.5	3*2.5+2.5	1–4	1–2.5
FI6	NXI_0016 5–0045 5	16–45	2*10	3*10+10	2.5–50 Cu	2.5–35
					6–50 Al	
FI7	NXI_0061 5	61	2*16	3*16+16	2.5–50 Cu	2.5–35
					6–50 Al	
	NXI_0072 5	72	2*25	3*25+16	2.5–50 Cu	6–70

Enclosure size	Drive type	I _L [A]	Supply cable Cu [mm ²]	Motor cable Cu [mm ²]	Main terminal cable [mm ²]	Earth terminal cable [mm ²]
	NXI_0087 5	87	2*35	3*35+16	6-50 Al	6-70
					2.5-50 Cu	
	NXI_0105 5	105	2*50	3*50+25	6-50 Al	
					2.5-50 Cu	
FI8	NXI_0140 5	140	2*70	3*70+35	2.5-50 Cu	25-95
					6-50 Al	

12.3.4 Cable Sizes for 640–1100 V DC (525–690 V AC)

Table 28: Cable Sizes for 640–1100 V DC (525–690 V AC)

Enclosure size	Drive type	I _L [A]	Supply cable Cu [mm ²]	Motor cable Cu [mm ²]	Main terminal cable [mm ²]	Earth terminal cable [mm ²]
FI6	NXI_0004 6-0007 6	3-7	2*2.5	3*2.5+2.5	2.5-50 Cu	2.5-35
					6-50 Al	
	NXI_0010 6-0013 6	10-13	2*2.5	3*2.5+2.5	2.5-50 Cu	2.5-35
					6-50 Al	
	NXI_0018 6	18	2*4	3*4+4	2.5-50 Cu	2.5-35
					6-50 Al	
	NXI_0022 6	22	2*6	3*6+6	2.5-50 Cu	2.5-35
					6-50 Al	
	NXI_0027 6-0034 6	27-34	2*10	3*10+10	2.5-50 Cu	2.5-35
					6-50 Al	
FI7	NXI_0041 6	41	2*100	3*10+10	2.5-50 Cu	6-50
					6-50 Al	
	NXI_0052 6	52	2*16	3*16+16	2.5-50 Cu	6-50
					6-50 Al	
FI8	NXI_0062-0080 6	62-80	2*25	3*25+16	25-95 Cu/Al	25-95

12.4 Cable Stripping Lengths

See [Illustration 46](#) for parts of cables to be stripped and check the corresponding stripping length in the table.

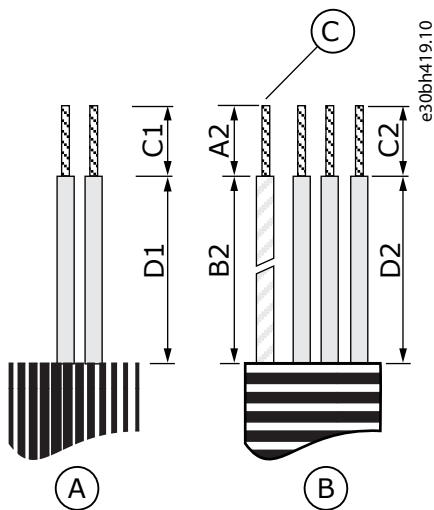

Illustration 46: Cable Stripping for DC Supply and Motor Cables

A	DC supply	C	Earth conductor
B	Motor		

Table 29: Cable Stripping Lengths [mm]

Enclosure size	C1	D1	A2	B2	C2	D2
FI4	10	20/70	7	50	7	35
FI6	15	60/80	20	90	15	60
FI7	25	120/140	25	120	25	120
FI8 0140	30	150	23 28	240	23	240

Table 30: Cable Stripping Lengths [in]

Enclosure size	C1	D1	A2	B2	C2	D2
FI4	0.39	0.79/2.76	0.28	1.97	0.28	1.38
FI6	0.59	2.36/3.15	0.79	3.54	0.59	2.36
FI7	0.98	4.72/5.51	0.98	4.72	0.98	4.72
FI8 0140	1.18	5.91	0.91	9.45	0.91	9.45

12.5 Tightening Torques for Cover Screws

Enclosure size and class	Cable cover screws (Nm)	Screws on the cover of the AC drive (Nm)
FR4/FI4 IP54	2.2	0.7
FR5 IP21/ IP54	2.2	0.7

Enclosure size and class	Cable cover screws (Nm)	Screws on the cover of the AC drive (Nm)
FR6/FI6 IP21/ IP54	2.2	0.7
FR7/FI7 IP21/ IP54	2.4	0.8
FR8/FI8 IP54	0.8 Nm ⁽¹⁾	0.8
FR9	0.8	0.8

¹ The cover of the power unit.

Enclosure size and class	Safety cover screws (Nm)
FR10 Standalone	4.2
FR11 Standalone	4.2

12.6 Tightening Torques of the Terminals

Table 31: Tightening Torques of the Terminals

Enclosure size	Drive type	Tightening torque (Nm)	Tightening torque (lb-in.)
FI4	0004 2–0012 2 0003 5–0012 5	0.5–0.6	4.5–5.3
FI6	0038 5–0061 5 0004 6–0034 6	10	88.5
FI7	0072 5–0105 5 0041 6–0080 6	10	88.5
FI8	0140 5 0062 6–0100 6	20 ⁽¹⁾	354

¹ Tightening torque of terminal connection to the insulative base is 9 Nm

12.7 Power Ratings

12.7.1 Overload Capability

The **low overload** means that if 110% of the continuous current (I_L) is required for 1 minute every 10 minutes, the remaining 9 minutes must be approximately 98% of I_L or less. This is to make sure that the output RMS current is not more than I_L during the duty cycle.

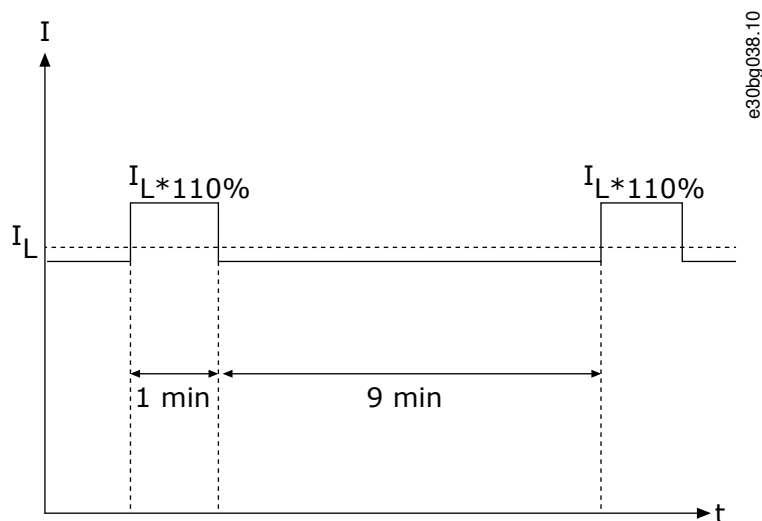

Illustration 47: Low Overload

The **high overload** means that if 150% of the continuous current (I_H) is required for 1 minute every 10 minutes, the remaining 9 minutes must be approximately 92% of I_H or less. This is to make sure that the output RMS current is not more than I_H during the duty cycle.

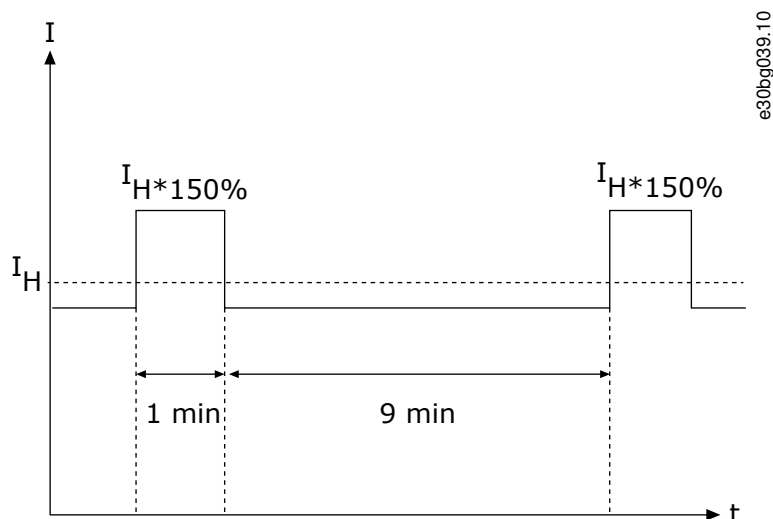

Illustration 48: High Overload

For more information, refer to the standard IEC61800-2.

12.7.2 Power Ratings for 465–800 V DC (380–500 V AC)

Table 32: Power Ratings in 465–800 V DC (380–500 V AC)

Inverter type	Enclosure size	Low loadability ⁽¹⁾ ⁽²⁾ : I^L [A]	Low loadability ⁽¹⁾ : 10% overload current I [A]	High loadability ⁽¹⁾ : I^H [A]	High loadability ⁽¹⁾ : 50% overload current I [A]	Loadability ⁽¹⁾ : Max current I^S	Motor shaft power ⁽³⁾ : 10% overload 40 °C [kW]	Motor shaft power ⁽³⁾ : 50% overload 50 °C [kW]	Motor shaft power ⁽⁴⁾ : 10% overload 40 °C [kW]	Motor shaft power ⁽⁴⁾ : 50% overload 50 °C [kW]
NXI_0004 5	FI4	4.3	4.7	3.3	5	6.2	1.5	1.1	2.2	1.5
NXI_0009 5	FI4	9	9.9	7.6	11.4	14	4	3	5.5	4
NXI_0012 5	FI4	12	13.2	9	13.5	18	5.5	4	7.5	5.5

Inverter type	Enclosure size	Low loadability ⁽¹⁾ ⁽²⁾ : I ^L [A]	Low loadability ⁽¹⁾ : 10% overload current I [A]	High loadability ⁽¹⁾ : I ^H [A]	High loadability ⁽¹⁾ : 50% overload current I [A]	Loadability ⁽¹⁾ : Max current I ^S	Motor shaft power ⁽³⁾ : 10% overload 40 °C [kW]	Motor shaft power ⁽³⁾ : 50% overload 50 °C [kW]	Motor shaft power ⁽⁴⁾ : 10% overload 40 °C [kW]	Motor shaft power ⁽⁴⁾ : 50% overload 50 °C [kW]
NXI_0016 5	FI6	16	17.6	12	18	24	7.5	5.5	11	7.5
NXI_0022 5	FI6	23	25.3	16	24	32	11	7.5	15	11
NXI_0031 5	FI6	31	34	23	35	46	15	11	18.5	15
NXI_0038 5	FI6	38	42	31	47	62	18.5	15	22	18.5
NXI_0045 5	FI6	46	51	38	57	76	22	18.5	30	22
NXI_0061 5	FI7	61	67	46	69	92	30	22	37	30
NXI_0072 5	FI7	72	79	61	92	122	37	30	45	37
NXI_0087 5	FI7	87	96	72	108	144	45	37	55	45
NXI_0105 5	FI7	105	116	87	131	174	55	45	75	55
NXI_0140 5	FI8	140	154	105	158	210	75	55	90	75

¹ At 40 °C ambient temperature

² The rated currents in given ambient temperatures are achieved only when the switching frequency is the same or smaller than the factory default. When a greater switching frequency is needed, the device must be derated. Contact your nearest Danfoss Drives representative.

³ 513 V DC supply

⁴ 675 V DC supply

12.7.3 Power Ratings for 640–1100 V DC (525–690 V AC)

Table 33: Power Ratings in 640–1100 V DC (525–690 V AC)

Inverter type	Enclosure size	Low loadability ⁽¹⁾⁽²⁾ : I ^L [A]	Low loadability ⁽¹⁾ : 10% overload current I [A]	High loadability ⁽¹⁾ : I ^H [A]	High loadability ⁽¹⁾ : 50% overload current I [A]	Loadability ⁽¹⁾ : Max current I _S	Motor shaft power ⁽³⁾ : 10% overload 40 °C [kW]	Motor shaft power ⁽³⁾ : 50% overload 50 °C [kW]
NXI_0004 6	FI6	4.5	5	3.2	5	6.7	3	2.2
NXI_0005 6	FI6	5.5	6.1	4.5	6.8	9	4	3
NXI_0007 6	FI6	7.5	8.3	5.5	8.3	11	5.5	4
NXI_0010 6	FI6	10	11	7.5	11.3	15	7.5	5.5
NXI_0013 6	FI6	13.5	14.9	10	15	20	11	7.5
NXI_0018 6	FI6	18	19.8	13.5	20.3	27	15	11
NXI_0022 6	FI6	22	24.2	18	27	36	18.5	15
NXI_0027 6	FI6	27	29.7	22	33	44	22	18.5
NXI_0034 6	FI6	34	37	27	41	54	30	22
NXI_0041 6	FI7	41	45	34	51	68	37.5	30

Inverter type	Enclosure size	Low loadability ⁽¹⁾⁽²⁾ : I ^L [A]	Low loadability ⁽¹⁾ : 10% overload current I [A]	High loadability ⁽¹⁾ : I ^H [A]	High loadability ⁽¹⁾ : 50% overload current I [A]	Loadability ⁽¹⁾ : Max current I _S	Motor shaft power ⁽³⁾ : 10% overload 40 °C [kW]	Motor shaft power ⁽³⁾ : 50% overload 50 °C [kW]
NXI_0052 6	FI7	52	57	41	62	82	45	37.5
NXI_0062 6	FI8	62	68	52	78	104	55	45
NXI_0080 6	FI8	80	88	62	93	124	75	55
NXI_0100 6	FI8	100	110	80	120	160	90	75

¹ At 40 °C ambient temperature

² The rated currents in given ambient temperatures are achieved only when the switching frequency is the same or smaller than the factory default. When a greater switching frequency is needed, the device must be derated. Contact your nearest Danfoss Drives representative.

³ 930 V DC supply

12.8 Technical Data

Table 34: Technical Data

Technical item or function		Technical data
DC connection	Input voltage U _{in}	465...800 V DC; 640...1100 V DC; -0%...+0%, the ripple voltage of the inverter supply voltage generated during the rectification of the basic frequency AC voltage must be less than 50 V P-P.
	Connection to DC supply	Once per minute or less (normal)
	Starting delay	FI4-FI8: 2 s
Motor connection	Output voltage	3 ~ 0 - U _{in} /1.4
	Constant output current	I _H : Ambient temperature maximum +50 °C (+122 °F), overload 1.5 x I _H (1 min/10 min) I _L : Ambient temperature maximum +40 °C (+104 °F), overload 1.1 x I _L (1 min/10 min)
	Starting torque	I _S for 2 s, depends on the motor
	Starting current	I _S for 2 s every 20 s
	Output frequency	0...320 Hz; 7200 Hz (special use)
	Frequency resolution	Depends on application
Control characteristics	Control method	Frequency control U/f Open Loop Sensorless Vector Control Closed Loop Frequency Control Closed Loop Vector Control
	Switching frequency (see parameter 2.6.9)	465-800 V DC (380-500 V AC) up to 0061: 1-16 kHz Default: 6 kHz 465-800 V DC (380-500 V AC) 0072 and larger: 1-6 kHz Default: 3.6 kHz 640-1000 V DC (525-690 V AC): 1-6 kHz Default: 1.5 kHz

Technical item or function		Technical data
	Analog input	Resolution 0.1% (10-bit), accuracy ±1%
	Panel reference	Resolution 0.01 Hz
	Field weakening point	30...320 Hz
	Acceleration time	0...3000 s
	Deceleration time	0...3000 s
Ambient conditions	Ambient operating temperature	-10 °C (no frost) (+14 °F)...+50 °C (+122 °F): I _H -10 °C (no frost) (+14 °F)...+40 °C (+104 °F): I _L
	Storage temperature	-40 °C (-40 °F)...+70 °C (158 °F)
	Relative humidity	0–95% RH, non-condensing, non-corrosive, no dripping water
	Air quality: • chemical vapors • mechanical particles	Designed according to: IEC 60721-3-3 Edition 2.2, unit in operation, class 3C3 IEC 60721-3-3 Edition 2.2, unit in operation, class 3S2
	Altitude	100% load capacity (no derating) up to 1000 m 1-% derating for each 100 m above 1000 m; maximum 500 V units: 3000 m, 690 V units: 2000 m
	Vibration IEC/EN 60068-2-6 IEC/EN 61800-5-1	5–150 Hz Displacement amplitude 1 mm (peak) at 5–15.8 Hz Maximum acceleration amplitude 1 G at 15.8–150 Hz
	Shock EN 50178, EN 60068-2-27	UPS Drop Test (for applicable UPS weights) Storage and shipping: Maximum 15 G, 11 ms (in package)
	Protection rating	FI4...FI7 IP21/NEMA1 standard FI8 IP00 standard/Open type standard size in the kW/HP range
Derating	The output power must be derated in following cases: • Ambient temperature is more than 40 °C (104 °F), see 5.1.2 Ambient Temperature and Derating . • Installation altitude is more than 1000 m, see 5.1.3 High Altitude Installation .	
EMC (at default settings)	Immunity	IEC/EN 61800-3
Safety standards		IEC/EN 61800-5-1, UL 508C, CSA C22.2 No.274
Approvals		CE, cULus, RCM, KC, EAC, UA (see nameplate of the drive for more approvals.) Marine approvals: LR, BV, DNV, GL, ABS, RMRS, CCS, KR
Efficiency		See https://www.danfoss.com/en/about-danfoss/our-business-es/drives/knowledge-center/energy-efficiency-directive/
Control connections	Analog input voltage	0...+10 V, R _i = 200 kW, (-10 V...+10 V joystick control) Resolution 0.1%, accuracy ±1%

Technical item or function		Technical data	
	Analog input current	0(4)...20 mA, Ri = 250 W differential	
	Digital inputs (6)	Positive or negative logic; 18...30 V DC	
	Auxiliary voltage	+24 V, ±15%, maximum 250 mA	
	Output reference voltage	+10 V, +3%, maximum load 10 mA	
	Analog output	0(4)...20 mA; RL maximum 500 W; Resolution 10 bit; Accuracy ±2%	
	Digital outputs	Open collector output, 50 mA/48 V	
	Relay outputs	2 programmable change-over relay outputs Switching capacity 24 V DC/8 A, 250 V AC/8 A, 125 V DC/0.4 A Minimum switching load: 5 V/10m A	
Protections	Overvoltage trip limit	NXI_5: 911 V DC NXI_6: 1200 V DC	
	Undervoltage trip limit	NXI_5: 333 V DC NXI_6: 460 V DC	
	Ground fault protection	If there is ground fault in motor or motor cable, only the inverter is protected	
	Output phase supervision	Trips if any of the output phases is missing	
	Overcurrent protection	Yes. ⁽¹⁾ The motor overload protection activates at 110% of the full load current.	
	Unit overtemperature protection	Yes	
	Motor overload protection	Yes	
	Motor stall protection	Yes	
	Motor underload protection	Yes	
	Short-circuit protection of +24 V and +10 V reference voltages	Yes	x fix- es

¹ For the motor thermal memory and the memory retention function to comply with the UL 508C requirements, use the system software version NXS00001V175, NXS00002V177, or NXP00002V186 or a newer version. With an older system software version, install a motor overtemperature protection to comply with the UL regulations.

12.9 DC Currents and DC Link Capacitance

For DC currents, see:

- [12.9.1 DC Currents, Supply Voltage 465–800 V DC](#)
- [12.9.2 DC Currents, Supply Voltage 640–1100 V DC](#)

For DC link capacitance, see [12.9.3 DC Link Capacitance](#).

12.9.1 DC Currents, Supply Voltage 465–800 V DC

Table 35: DC Currents of VACON[®]NX, Supply Voltage 465–800 V DC

Structure	I _N (output)	Motor cos	I _{DC} (input)
FI4	4.3	0.79	4.4
	9	0.82	9.6
	12	0.83	1.0
FI6	16	0.84	17.5
	22	0.85	24.4
	31	0.85	34.3
	38	0.86	43
	45	0.86	50
FI7	61	0.86	68
	72	0.87	82
	87	0.87	99
	105	0.87	119
FI8	140	0.88	160

12.9.2 DC Currents, Supply Voltage 640–1100 V DC

Table 36: DC Currents of VACON[®]NX, Supply Voltage 640–1100 V DC

Structure	I _N (output)	Motor cos	I _{DC} (input)
FI6	4.5	0.81	4.7
	5.5	0.82	5.9
	7.5	0.83	8.1
	10.0	0.84	10.9
	13.5	0.85	14.9
	18.0	0.85	19.9
	22.0	0.86	24.6
	27.0	0.86	30.2
	34.0	0.86	38.1
FI7	41.0	0.87	46
	52.0	0.87	59
FI8	62.0	0.87	70
	80.0	0.88	92
	100.0	0.88	115

12.9.3 DC Link Capacitance

Table 37: DC Link Capacitance

Structure	NXI_5 / mF	NXI_6 / mF
F14 0003–0007	165	–
F14 0009–0012	235	
F16	1000	500
F17	1650	900
F18	3300	1800

12.10 Faults and Alarms

12.10.1 Fault 1 - Overcurrent, Subcode S1 - Hardware trip

Cause

There is too high a current in the motor cable. Its cause can be 1 of the following:

- A sudden heavy load increase
- A short circuit in the motor cables
- The motor is not the correct type

Troubleshooting

- Check the load.
- Check the motor.
- Check the cables and connections.
- Make an identification run.

12.10.2 Fault 1 - Overcurrent, Subcode S3 - Current limit controller supervision

Cause

There is too high a current in the motor cable. Its cause can be 1 of the following:

- A sudden heavy load increase
- A short circuit in the motor cables
- The motor is not the correct type

Troubleshooting

- Check the load.
- Check the motor.
- Check the cables and connections.
- Make an identification run.

12.10.3 Fault 1 - Overcurrent, Subcode S4 - Software-based overcurrent fault

Cause

There is too high a current in the motor cable. Its cause can be 1 of the following:

- A sudden heavy load increase
- A short circuit in the motor cables
- The motor is not the correct type

Troubleshooting

- Check the load.
- Check the motor.
- Check the cables and connections.
- Make an identification run.

12.10.4 Fault 2 - Overvoltage, Subcode S1 - Hardware trip

Cause

The DC-link voltage is higher than the limits.

- Too short a deceleration time
- High overvoltage spikes in the supply
- Start/Stop sequence too fast

Troubleshooting

- Set the deceleration time longer.
- Use the brake chopper or the brake resistor. They are available as options.
- Activate the overvoltage controller.
- Do a check of the input voltage.

12.10.5 Fault 2 - Overvoltage, Subcode S2 - Overvoltage control supervision

Cause

The DC-link voltage is higher than the limits.

- Too short a deceleration time
- High overvoltage spikes in the supply
- Motor load is generative
- Start/Stop sequence too fast

Troubleshooting

- Set the deceleration time longer.
- Use the brake chopper or the brake resistor. They are available as options.
- Activate the overvoltage controller.
- Do a check of the input voltage.

12.10.6 Fault 3 - Earth fault

Cause

The measurement of current tells that the sum of the motor phase current is not zero.

- Insulation malfunction in the cables or in the motor.

It is possible to set different responses in the application for this fault. See parameter group Protections.

Troubleshooting

Do a check of the motor cables and the motor.

12.10.7 Fault 5 - Charging switch

Cause

The charging switch is open, when the START command is given.

- Operation malfunction
- Defective component

Troubleshooting

- Reset the fault and start the drive again.
- If the fault shows again, ask instructions from the local distributor.

12.10.8 Fault 6 - Emergency stop

Cause

Stop signal has been given from the option board.

Troubleshooting

Do a check of the emergency stop circuit.

12.10.9 Fault 7 - Saturation trip

Cause

- Defective component
- Brake resistor short circuit or overload

Troubleshooting

This fault cannot be reset from the control panel.

- Switch off the power.
- DO NOT RESTART THE DRIVE OR CONNECT THE POWER!
- Ask instructions from the factory. If this fault shows at the same time with Fault 1, do a check of the motor cable and the motor.

12.10.10 Fault 8 - System fault, Subcode S1 - ASIC phase feedback

Cause

- Operation malfunction
- Defective component

Troubleshooting

- Reset the fault and start the drive again.
- If the fault shows again, ask instructions from the local distributor.

12.10.11 Fault 8 - System fault, Subcode S4 - ASIC trip

Cause

- Operation malfunction
- Defective component

Troubleshooting

- Reset the fault and start the drive again.
- If the fault shows again, ask instructions from the local distributor.

12.10.12 Fault 8 - System fault, Subcode S5 - Disturbance in VaconBus

Cause

- Operation malfunction
- Defective component

Troubleshooting

- Reset the fault and start the drive again.
- If the fault shows again, ask instructions from the local distributor.

12.10.13 Fault 8 - System fault, Subcode S6 - Feedback of charging switch

Cause

- Operation malfunction
- Defective component

Troubleshooting

- Reset the fault and start the drive again.
- If the fault shows again, ask instructions from the local distributor.

12.10.14 Fault 8 - System fault, Subcode S7 - Charging switch

Cause

- Operation malfunction
- Defective component

Troubleshooting

- Reset the fault and start the drive again.
- If the fault shows again, ask instructions from the local distributor.

12.10.15 Fault 8 - System fault, Subcode S8 - No power to driver card

Cause

- Operation malfunction
- Defective component

Troubleshooting

- Reset the fault and start the drive again.
- If the fault shows again, ask instructions from the local distributor.

12.10.16 Fault 8 - System fault, Subcode S9 - Power unit communication (TX)

Cause

- Operation malfunction
- Defective component

Troubleshooting

- Reset the fault and start the drive again.
- If the fault shows again, ask instructions from the local distributor.

12.10.17 Fault 8 - System fault, Subcode S10 - Power unit communication (Trip)

Cause

- Operation malfunction
- Defective component

Troubleshooting

- Reset the fault and start the drive again.
- If the fault shows again, ask instructions from the local distributor.

12.10.18 Fault 8 - System fault, Subcode S11 - Power unit comm. (Measurement)

Cause

- Operation malfunction
- Defective component

Troubleshooting

- Reset the fault and start the drive again.
- If the fault shows again, ask instructions from the local distributor.

12.10.19 Fault 8 - System fault, Subcode S12 - System bus fault (slot D or E)

Cause

Error in system bus option board (OPTD1 or OPTD2) in slot D or E.

- Operation malfunction
- Defective component

Troubleshooting

- Reset the fault and start the drive again.
- If the fault shows again, ask instructions from the local distributor.
- Check the cables and connections.

12.10.20 Fault 8 - System fault, Subcode S30 - OPTAF: STO channels are different from each other

Cause

The Safe Disable inputs are in different states. It is not allowed according to EN954-1, category 3. This fault occurs when the Safe Disable inputs are in different states for more than 5 s.

Troubleshooting

- Check the S1 switch.
- Check the cabling to the OPTAF board.
- If the fault shows again, ask instructions from the local distributor.

12.10.21 Fault 8 - System fault, Subcode S31 - OPTAF: Thermistor short circuit detected

Cause

Thermistor short circuit detected.

Troubleshooting

- Correct the cable connections.
- Check the jumper for the thermistor short circuit supervision, if the thermistor function is not used and the thermistor input is short-circuited.

12.10.22 Fault 8 - System fault, Subcode S32 - OPTAF board has been removed

Cause

OPTAF board has been removed. It is not allowed to remove the OPTAF board once the software has recognized it.

Troubleshooting

The system requires a manual acknowledgement using *System* menu parameter P6.5.5 OPTAF Remove. Ask help from the local distributor.

12.10.23 Fault 8 - System fault, Subcode S33 - OPTAF: EEPROM error

Cause

OPTAF board EEPROM error (checksum, not answering and so on).

Troubleshooting

Change the OPTAF board.

12.10.24 Fault 8 - System fault, Subcode S34 - OPTAF: Voltage problem

Cause

OPTAF supply voltage hardware problem detected.

Troubleshooting

Change the OPTAF board.

12.10.25 Fault 8 - System fault, Subcode S35 - OPTAF: Overvoltage

Cause

OPTAF supply voltage hardware problem detected.

Troubleshooting

Change the OPTAF board.

12.10.26 Fault 8 - System fault, Subcode S36 - OPTAF: Undervoltage

Cause

OPTAF supply voltage hardware problem detected.

Troubleshooting

Change the OPTAF board.

12.10.27 Fault 8 - System fault, Subcode S37 - OPTAF: Test pulse is not detected in both STO channels

Cause

Single hardware problem detected in Safe Disable inputs.

Troubleshooting

- Change the OPTAF board.
- Change the control board.

12.10.28 Fault 8 - System fault, Subcode S38 - OPTAF: Test pulse is not detected in STO channel 1

Cause

Single hardware problem detected in Safe Disable inputs.

Troubleshooting

- Change the OPTAF board.
- Change the control board.

12.10.29 Fault 8 - System fault, Subcode S39 - OPTAF: Test pulse is not detected in STO channel 2

Cause

Single hardware problem detected in Safe Disable inputs.

Troubleshooting

- Change the OPTAF board.
- Change the control board.

12.10.30 Fault 8 - System fault, Subcode S40 - OPTAF: ASIC trip ETR is not set, even if STO channel 1 is active

Cause

Single hardware problem detected in Safe Disable inputs.

Troubleshooting

- Change the OPTAF board.
- Change the control board.

12.10.31 Fault 8 - System fault, Subcode S41 - OPTAF: STO channels are not active when the thermistor trip is active

Cause

Single hardware problem detected in the thermistor input.

Troubleshooting

Change the OPTAF board.

12.10.32 Fault 8 - System fault, Subcode S42 - OPTAF: Test pulse low is not detected on thermistor

Cause

Single hardware problem detected in the thermistor input.

Troubleshooting

Change the OPTAF board.

12.10.33 Fault 8 - System fault, Subcode S43 - OPTAF: Test pulse high is not detected on thermistor

Cause

Single hardware problem detected in the thermistor input.

Troubleshooting

Change the OPTAF board.

12.10.34 Fault 8 - System fault, Subcode S44 - OPTAF: STO channel 1 is not active, even if the analog input supervision indicates

Cause

Single hardware problem detected in Safe Disable inputs or in the thermistor input.

Troubleshooting

- Change the OPTAF board.
- Change the control board.

12.10.35 Fault 8 - System fault, Subcode S45 - OPTAF: STO channel 2 is not active, even if the analog input supervision indicates

Cause

Single hardware problem detected in Safe Disable inputs or in the thermistor input.

Troubleshooting

- Change the OPTAF board.
- Change the control board.

12.10.36 Fault 8 - System fault, Subcode S46 - OPTAF: Thermistor or analog input is not set, even if STO is active

Cause

Single hardware problem detected in Safe Disable inputs or in the thermistor input.

Troubleshooting

- Change the OPTAF board.
- Change the control board.

12.10.37 Fault 8 - System fault, Subcode S47 - OPTAF: Board mounted in old NXP control board with no safety hardware

Cause

OPTAF board mounted in old VACON[®]NXP control board, which is not equipped with the Safe Disable function.

Troubleshooting

Change the control board to VB00561 revision H or newer.

12.10.38 Fault 8 - System fault, Subcode S48 - OPTAF: Mismatch between Therm Trip (HW) parameter and jumper setting

Cause

The parameter Expander boards/ SlotB/ Therm Trip(HW) is set to OFF even though the jumper X12 is not cut.

Troubleshooting

Correct the parameter P7.2.1.1 Therm Trip (HW) to match the X12 jumper setting.

12.10.39 Fault 8 - System fault, Subcode S50 - OPTAF: Filter discharge resistor fault

Cause

Problem with the control board.

Troubleshooting

Ask instructions from the local distributor.

12.10.40 Fault 8 - System fault, Subcode S70 - False fault activated

Cause

Fault in application.

Troubleshooting

Ask instructions from the local distributor.

12.10.41 Fault 9 - Undervoltage, Subcode S1 - DC-link too low during run

Cause

The DC-link voltage is lower than the limits.

- Too low a supply voltage
- AC drive internal fault
- A defective input fuse
- The external charge switch is not closed.

It is possible to set different responses in the application for this fault. See parameter group Protections.

Troubleshooting

- If there is a temporary supply voltage break, reset the fault and start the drive again.
- Do a check of the supply voltage. If the supply voltage is sufficient, there is an internal fault.
- Ask instructions from the local distributor.

12.10.42 Fault 9 - Undervoltage, Subcode S2 - No data from power unit

Cause

The DC-link voltage is lower than the limits.

- Too low a supply voltage
- AC drive internal fault
- a defective input fuse
- the external charge switch is not closed.

It is possible to set different responses in the application for this fault. See parameter group Protections.

Troubleshooting

- If there is a temporary supply voltage break, reset the fault and start the drive again.
- Do a check of the supply voltage. If the supply voltage is sufficient, there is an internal fault.
- Ask instructions from the local distributor.

12.10.43 Fault 9 - Undervoltage, Subcode S3 - Undervoltage control supervision

Cause

The DC-link voltage is lower than the limits.

- Too low a supply voltage
- AC drive internal fault
- A defective input fuse
- The external charge switch is not closed.

It is possible to set different responses in the application for this fault. See parameter group Protections.

Troubleshooting

- If there is a temporary supply voltage break, reset the fault and start the drive again.
- Do a check of the supply voltage. If the supply voltage is sufficient, there is an internal fault.
- Ask instructions from the local distributor.

12.10.44 Fault 10 - Input line supervision, Subcode S1 - Phase supervision diode supply

Cause

The input line phase is missing.

It is possible to set different responses in the application for this fault. See parameter group Protections.

Troubleshooting

Do a check of the supply voltage, the fuses, and supply cable.

12.10.45 Fault 11 - Output phase supervision, Subcode S1 - Common output phase supervision

Cause

The measurement of current tells that there is no current in 1 motor phase.

It is possible to set different responses in the application for this fault. See parameter group Protections.

Troubleshooting

Do a check of the motor cable and the motor.

12.10.46 Fault 11 - Output phase supervision, Subcode S2 - Additional closed loop control output phase fault

Cause

The measurement of current tells that there is no current in 1 motor phase.

It is possible to set different responses in the application for this fault. See parameter group Protections.

Troubleshooting

Do a check of the motor cable and the motor.

12.10.47 Fault 11 - Output phase supervision, Subcode S3 - Additional open loop control output phase fault during start DC brake

Cause

The measurement of current tells that there is no current in 1 motor phase.

It is possible to set different responses in the application for this fault. See parameter group Protections.

Troubleshooting

Do a check of the motor cable and the motor.

12.10.48 Fault 11 - Output phase supervision, Subcode S4 - Additional closed loop output phase fault during PM StartAngleID run

Cause

The measurement of current tells that there is no current in 1 motor phase.

It is possible to set different responses in the application for this fault. See parameter group Protections.

Troubleshooting

Do a check of the motor cable and the motor.

12.10.49 Fault 12 - Brake chopper supervision

Cause

- There is no brake resistor.
- The brake resistor is broken.
- A defective brake chopper.

Troubleshooting

- Do a check of the brake resistor and the cabling.
- If they are in good condition, there is a fault in the resistor or the brake chopper. Ask instructions from the local distributor.

12.10.50 Fault 13 - AC drive undertemperature

Cause

Too low a temperature in the heat sink of the power unit or in the power board. The heat sink temperature is below -10 °C (14 °F).

Troubleshooting

Add an external heater near the AC drive.

12.10.51 Fault 14 - AC drive overtemperature, Subcode S1 - Overtemperature warning in unit, board, or phases

Cause

Overheating detected in AC drive.

Heat sink temperature is over 90 °C (194 °F). Overtemperature alarm is issued when the heat sink temperature goes over 85 °C (185 °F).

In 525–690 V, FR6: Heat sink temperature is over 77 °C (170.6 °F). Overtemperature alarm is issued when the heat sink temperature goes over 72 °C (161.6 °F).

Troubleshooting

- Do a check of the actual amount and flow of cooling air.
- Examine the heat sink for dust.
- Do a check of the ambient temperature.
- Make sure that the switching frequency is not too high in relation to the ambient temperature and the motor load.
- For FR10-FR11 Standalone: check door filters, and clean or replace if needed.

12.10.52 Fault 14 - AC drive overtemperature, Subcode S2 - Overtemperature in power board

Cause

Overheating detected in AC drive.

Heat sink temperature is over 90 °C (194 °F). Overtemperature alarm is issued when the heat sink temperature goes over 85 °C (185 °F).

In 525–690 V, FR6: Heat sink temperature is over 77 °C (170.6 °F). Overtemperature alarm is issued when the heat sink temperature goes over 72 °C (161.6 °F).

Troubleshooting

- Do a check of the actual amount and flow of cooling air.
- Examine the heat sink for dust.
- Do a check of the ambient temperature.
- Make sure that the switching frequency is not too high in relation to the ambient temperature and the motor load.
- For FR10-FR11 Standalone: check door filters, and clean or replace if needed.

12.10.53 Fault 14 - AC drive overtemperature, Subcode S4 - Overtemperature on ASIC board or driver boards

Cause

Overheating detected in AC drive.

Heat sink temperature is over 90 °C (194 °F). Overtemperature alarm is issued when the heat sink temperature goes over 85 °C (185 °F).

In 525–690 V, FR6: Heat sink temperature is over 77 °C (170.6 °F). Overtemperature alarm is issued when the heat sink temperature goes over 72 °C (161.6 °F).

Troubleshooting

- Do a check of the actual amount and flow of cooling air.
- Examine the heat sink for dust.
- Do a check of the ambient temperature.
- Make sure that the switching frequency is not too high in relation to the ambient temperature and the motor load.
- For FR10-FR11 Standalone: check door filters, and clean or replace if needed.

12.10.54 Fault 15 - Motor stalled

Cause

The motor stalled.

It is possible to set different responses in the application for this fault. See parameter group Protections.

Troubleshooting

- Check the motor and the load.
- Insufficient motor power, check motor stall protection parameterization.

12.10.55 Fault 16 - Motor overtemperature

Cause

There is too heavy a load on the motor.

It is possible to set different responses in the application for this fault. See parameter group Protections.

Troubleshooting

- Decrease the motor load.
- If there is no motor overload, do a check of the temperature model parameters.

12.10.56 Fault 17 - Motor underload

Cause

Motor underload protection has tripped.

It is possible to set different responses in the application for this fault. See parameter group Protections.

Troubleshooting

- Check the load.
- Check underload protection parameterization.

12.10.57 Fault 18 - Unbalance, Subcode S1 - Current unbalance

Cause

Unbalance between power modules in paralleled power units.

This fault is type A fault (Alarm).

Troubleshooting

If the fault occurs again, ask instructions from the local distributor.

12.10.58 Fault 18 - Unbalance, Subcode S2 - DC voltage unbalance

Cause

Unbalance between power modules in paralleled power units.

This fault is type A fault (Alarm).

Troubleshooting

If the fault occurs again, ask instructions from the local distributor.

12.10.59 Fault 19 - Current overload

Cause

Motor current overload warning.

Troubleshooting

Ask instructions from the local distributor.

12.10.60 Fault 22 - Parameter fault, Subcode S1 - Firmware interface power down variable check-sum error

Cause

Parameter save fault.

- Operation malfunction
- defective component

Troubleshooting

If the fault occurs again, ask instructions from the local distributor.

12.10.61 Fault 22 - Parameter fault, Subcode S2 - Firmware interface variable check sum error

Cause

Parameter save fault.

- Operation malfunction
- defective component

Troubleshooting

If the fault occurs again, ask instructions from the local distributor.

12.10.62 Fault 22 - Parameter fault, Subcode S3 - System power down variable check sum error

Cause

Parameter save fault.

- Operation malfunction
- defective component

Troubleshooting

If the fault occurs again, ask instructions from the local distributor.

12.10.63 Fault 22 - Parameter fault, Subcode S4 - System parameter checksum error

Cause

Parameter save fault.

- Operation malfunction
- defective component

Troubleshooting

If the fault occurs again, ask instructions from the local distributor.

12.10.64 Fault 22 - Parameter fault, Subcode S5 - Application-defined power-down, variable check-sum error

Cause

Parameter save fault.

- Operation malfunction
- defective component

Troubleshooting

If the fault occurs again, ask instructions from the local distributor.

12.10.65 Fault 22 - Parameter fault, Subcode S6 - Application-defined power-down, variable check-sum

Cause

Parameter save fault.

- Operation malfunction
- defective component

Troubleshooting

If the fault occurs again, ask instructions from the local distributor.

12.10.66 Fault 22 - Parameter fault, Subcode S10 - System parameter checksum error

Cause

Parameter save fault.

- Operation malfunction
- defective component

Troubleshooting

If the fault occurs again, ask instructions from the local distributor.

12.10.67 Fault 22 - Parameter fault, Subcode S13 - Checksum error in application-specific parameter set

Cause

Parameter save fault.

Troubleshooting

- Recommission the application.
- Check parameters.

12.10.68 Fault 24 - Counter fault

Cause

Values that showed on the counters are incorrect.

Troubleshooting

Have a critical attitude towards values shown on counters.

12.10.69 Fault 25 - Microprocessor watchdog fault, Subcode S1 - CPU watchdog timer

Cause

- operation malfunction
- defective component

Troubleshooting

- Reset the fault and start the drive again.
- If the fault shows again, ask instructions from the local distributor.

12.10.70 Fault 25 - Microprocessor watchdog fault, Subcode S2 - ASIC reset

Cause

- operation malfunction
- defective component

Troubleshooting

- Reset the fault and start the drive again.
- If the fault shows again, ask instructions from the local distributor.

12.10.71 Fault 26 - Start-up prevented, Subcode S1 - Prevention of accidental start-up

Cause

Start-up of the drive has been prevented. Run request is ON when new application is downloaded to the drive.

Troubleshooting

- Cancel prevention of start-up if it can be done safely.
- Remove Run request.

12.10.72 Fault 26 - Start-up prevented, Subcode S2 - RUN request is kept active after drive returns to READY state from safe state

Cause

Start-up of the drive has been prevented. START command is ON when returning to READY state after Safe Disable has been active.

Troubleshooting

- Cancel prevention of start-up if it can be done safely.
- Remove Run request.

12.10.73 Fault 26 - Start-up prevented, Subcode S30 - RUN request given too quickly

Cause

Start-up of the drive has been prevented. START command is ON after system software or application was downloaded, or after application was changed.

Troubleshooting

- Cancel prevention of start-up if it can be done safely.
- Remove Run request.

12.10.74 Fault 29 - Thermistor fault, Subcode S1 - Thermistor input activated on OPTAF board

Cause

The thermistor input of option board has detected increase of the motor temperature.

It is possible to set different responses in the application for this fault. See parameter group Protections.

Troubleshooting

- Do a check of the motor cooling and loading.
- Do a check of the thermistor connection.
- (If thermistor input of the option board is not in use it has to be short-circuited).

12.10.75 Fault 29 - Thermistor fault, Subcode S2 - Special application

Cause

The thermistor input of option board has detected increase of the motor temperature.

It is possible to set different responses in the application for this fault. See parameter group Protections.

Troubleshooting

- Do a check of the motor cooling and loading.
- Do a check of the thermistor connection.
- (If thermistor input of the option board is not in use it has to be short-circuited).

12.10.76 Fault 30 - Safe disable

Cause

The input on OPTAF board has opened.

STO inputs SD1 and SD2 are activated through the OPTAF option board.

Troubleshooting

Cancel Safe Disable if it can be done safely.

12.10.77 Fault 31 - IGBT temperature (hardware)

Cause

IGBT Inverter Bridge overtemperature protection has detected too high a short-term overload current.

Troubleshooting

- Check the load.
- Check the motor frame size.
- Make an identification run.

12.10.78 Fault 32 - Fan cooling

Cause

Cooling fan of the AC drive does not start, when ON command is given.

Troubleshooting

Ask instructions from the local distributor.

12.10.79 Fault 34 - CAN bus communication

Cause

Sent message not acknowledged.

Troubleshooting

Make sure that there is another device on the bus with the same configuration.

12.10.80 Fault 35 - Application

Cause

Problem in application software.

Troubleshooting

- Ask instructions from the local distributor.
- For an application programmer: do a check of the application program.

12.10.81 Fault 36 - Control unit

Cause

- The software needs newer version of the control unit.

Troubleshooting

- Change the control unit.

12.10.82 Fault 37 - Device changed (same type), Subcode S1 - Control board

Cause

A new option board has replaced the old one in the same slot. The parameters are available in the drive.

Troubleshooting

Reset the fault. The device is ready for use. The drive starts to use the old parameter settings.

12.10.83 Fault 38 - Device added (same type), Subcode S1 - Control board

Cause

The option board was added. The same option board has been used in the same slot before. The parameters are available in the drive.

Troubleshooting

Reset the fault. The device is ready for use. The drive starts to use the old parameter settings.

12.10.84 Fault 39 - Device removed

Cause

An option board was removed from the slot.

Troubleshooting

The device is not available. Reset the fault.

12.10.85 Fault 40 - Device unknown, Subcode S1 - Unknown device

Cause

An unknown or mismatching device was connected (the power unit or option board).

Troubleshooting

Ask instructions from the local distributor.

12.10.86 Fault 40 - Device unknown, Subcode S2 - StarCoupler: power sub units are not identical

Cause

An unknown or mismatching device was connected (the power unit or option board).

Troubleshooting

Ask instructions from the local distributor.

12.10.87 Fault 40 - Device unknown, Subcode S3 - StarCoupler is not compatible with the control board

Cause

An unknown or mismatching device was connected (the power unit or option board).

Troubleshooting

Ask instructions from the local distributor.

12.10.88 Fault 40 - Device unknown, Subcode S4 - Wrong PropertiesType in control board EEPROM

Cause

An unknown or mismatching device was connected (the power unit or option board).

Troubleshooting

Ask instructions from the local distributor.

12.10.89 Fault 40 - Device unknown, Subcode S5 - Wrong VACON® NXP control board EEPROM size detected

Cause

An unknown or mismatching device was connected (the power unit or option board).

Troubleshooting

Ask instructions from the local distributor.

12.10.90 Fault 40 - Device unknown, Subcode S6 - Old power unit (Asic) and new software mismatch

Cause

An unknown or mismatching device was connected (the power unit or option board).

Troubleshooting

Ask instructions from the local distributor.

12.10.91 Fault 40 - Device unknown, Subcode S7 - Old ASIC detected

Cause

An unknown or mismatching device was connected (the power unit or option board).

Troubleshooting

Ask instructions from the local distributor.

12.10.92 Fault 41 - IGBT temperature, Subcode S1 - Calculated IGBT temperature too high

Cause

IGBT Inverter Bridge overtemperature protection has detected too high a short-term overload current.

Troubleshooting

- Check the load.
- Check the motor frame size.
- Make an identification run.

12.10.93 Fault 41 - IGBT temperature, Subcode S3 - Calculated IGBT temperature too high (long-term protection)

Cause

IGBT Inverter Bridge overtemperature protection has detected too high a short-term overload current.

Troubleshooting

- Check the load.
- Check the motor frame size.
- Make an identification run.

12.10.94 Fault 41 - IGBT temperature, Subcode S4 - Peak current too high

Cause

IGBT Inverter Bridge overtemperature protection has detected too high a short-term overload current.

Troubleshooting

- Check the load.
- Check the motor frame size.
- Make an identification run.

12.10.95 Fault 41 - IGBT temperature, Subcode S5 - BCU: Filtered current too high for some time

Cause

IGBT Inverter Bridge overtemperature protection has detected too high a short-term overload current.

Troubleshooting

- Check the load.
- Check the motor frame size.
- Make an identification run.

12.10.96 Fault 41 - IGBT temperature, Subcode S6 - BCU: Current momentarily too high

Cause

IGBT Inverter Bridge overtemperature protection has detected too high a short-term overload current.

Troubleshooting

- Check the load.
- Check the motor frame size.
- Make an identification run.
- Check brake resistor resistance.

12.10.97 Fault 42 - Brake resistor overtemperature, Subcode S1 - Internal brake chopper overtemperature

Cause

Brake resistor overtemperature protection has detected too heavy braking.

Troubleshooting

- Reset unit.
- Set the deceleration time longer.
- Dimensioning of the brake chopper is not correct.
- Use external brake resistor.

12.10.98 Fault 42 - Brake resistor overtemperature, Subcode S2 - Brake resistance too high (BCU)

Cause

Brake resistor overtemperature protection has detected too heavy braking.

Troubleshooting

- Reset unit.
- Set the deceleration time longer.
- Dimensioning of the brake chopper is not correct.
- Use external brake resistor.

12.10.99 Fault 42 - Brake resistor overtemperature, Subcode S3 - Brake resistance too low (BCU)

Cause

Brake resistor overtemperature protection has detected too heavy braking.

Troubleshooting

- Reset unit.
- Set the deceleration time longer.
- Dimensioning of the brake chopper is not correct.
- Use external brake resistor.

12.10.100 Fault 42 - Brake resistor overtemperature, Subcode S4 - Brake resistance not detected (BCU)

Cause

Brake resistor overtemperature protection has detected too heavy braking.

Troubleshooting

- Reset unit.
- Set the deceleration time longer.
- Dimensioning of the brake chopper is not correct.
- Use external brake resistor.

12.10.101 Fault 42 - Brake resistor overtemperature, Subcode S5 - Brake resistance leakage (earth fault) (BCU)

Cause

Brake resistor overtemperature protection has detected too heavy braking.

Troubleshooting

- Reset unit.
- Set the deceleration time longer.
- Dimensioning of the brake chopper is not correct.
- Use external brake resistor.

12.10.102 Fault 43 - Encoder fault, Subcode S1 - Encoder 1 channel A is missing

Cause

Problem detected in encoder signals.

Encoder channel A is missing.

Troubleshooting

- Do a check of the encoder connections.
- Do a check of the option board.
- Measure the encoder pulses.
 - If the pulses are correct, the option board is faulty.
 - If the pulses are not correct, the encoder/cabling is faulty.

12.10.103 Fault 43 - Encoder fault, Subcode S2 - Encoder 1 channel B is missing

Cause

Problem detected in encoder signals.

Encoder channel B is missing.

Troubleshooting

- Do a check of the encoder connections.
- Do a check of the option board.
- Measure the encoder pulses.
 - If the pulses are correct, the option board is faulty.
 - If the pulses are not correct, the encoder/cabling is faulty.

12.10.104 Fault 43 - Encoder fault, Subcode S3 - Both encoder 1 channels are missing

Cause

Problem detected in encoder signals.

Encoder channels A and B are missing.

Troubleshooting

- Do a check of the encoder connections.
- Do a check of the option board.
- Measure the encoder pulses.
 - If the pulses are correct, the option board is faulty.
 - If the pulses are not correct, the encoder/cabling is faulty.

12.10.105 Fault 43 - Encoder fault, Subcode S4 - Encoder reversed

Cause

Problem detected in encoder signals.

The encoder is reversed. The output frequency has been set to the positive value, but the encoder signal is negative.

Troubleshooting

Change the frequency value polarity so that the encoder signal is positive. With some encoders, interchanging the encoder channels can be used to change the indicated rotation direction.

12.10.106 Fault 43 - Encoder fault, Subcode S5 - Encoder board missing

Cause

The encoder board is missing.

Troubleshooting

- Do a check of the encoder board.
- Do a check of the terminals.
- Do a check of the board connections.

12.10.107 Fault 43 - Encoder fault, Subcode S6 - Serial communication fault

Cause

Problem detected in encoder signals.

Serial communication fault. The encoder cable is not connected or there are interferences in the cable.

Troubleshooting

- Check cabling between encoder and OPTBE, especially Data and Clock signals.
- Check that actual encoder type matches with OPTBE "Operating mode" parameter.

12.10.108 Fault 43 - Encoder fault, Subcode S7 - Ch A / Ch B Mismatch

Cause

Problem detected in encoder signals.

Encoder channels A and B are mismatched.

Troubleshooting

Do a check of the cable connections and terminals.

12.10.109 Fault 43 - Encoder fault, Subcode S8 - Resolver/Motor pole pair mismatch

Cause

Problem detected in parameterization of option board.

There is a mismatch of the resolver/ motor pole pair number. Resolver pole pair number (if >1) is not matching the motor pole pair number.

Troubleshooting

Check that OPTBC parameter "Resolver Poles" and possible Gear Ratio parameters in application match motor pole count.

12.10.110 Fault 43 - Encoder fault, Subcode S9 - Missed Start Angle

Cause

Encoder zero positioning identification run has not been made.

The encoder start angle is missing.

Troubleshooting

Make encoder identification run.

12.10.111 Fault 43 - Encoder fault, Subcode S10 - Sin/Cos encoder feedback is missing

Cause

Problem detected in encoder signals.

For the closed loop control, encoder modes "EnDat only" or "SSI only" (absolute channel only) are not allowed.

Troubleshooting

- Do a check of the wiring, jumper settings, and encoder mode.
- Change OPTBE "Operating mode" parameter is either "EnDat+SinCos", "SSI+SinCos" or "SinCos only", or avoid using closed loop control.

12.10.112 Fault 43 - Encoder fault, Subcode S11 - Encoder angle is drifting

Cause

Error angle between the angle read from the absolute channel and the angle calculated from the incremental channels.

Troubleshooting

- Check the encoder cable, cable shield, and grounding of the cable shield.
- Check the mechanical mounting of the encoder and make sure that the encoder is not slipping.
- Check the encoder parameters (for example, encoder ppr).

12.10.113 Fault 43 - Encoder fault, Subcode S12 - Dual speed supervision fault

Cause

Encoder speed supervision. The difference between the encoder speed and estimated speed is too large. Dual speed supervision: Estimated speed and encoder speed difference is too high ($0.05 \times f_n$ or minimum motor nominal slip frequency). See variable EstimatedShaftFrequency.

Troubleshooting

- Check the encoder speed signal ShaftFrequency vs. EstimatedShaftFrequency.
- If the ShaftFrequency is incorrect, check the encoder, cable, and encoder parameters.
- If the EstimatedShaftFrequency is incorrect, check the motor parameters.

12.10.114 Fault 43 - Encoder fault, Subcode S13 - Encoder angle supervision fault

Cause

The estimated shaft position error (estimated angle - encoder angle) is more than 90° electrical.

See variable EstimatedAngleError.

Troubleshooting

- Repeat the encoder ID run (absolute encoders).
- Check the mechanical mounting of the encoder and make sure that the encoder is not slipping.
- Check the encoder ppr number.
- Check the encoder cable.

12.10.115 Fault 43 - Encoder fault, Subcode S14 - Encoder estimated missing pulse fault, switch from the CL ctrl to the OL sensorl

Cause

Problem detected in encoder signals.

Software has detected too many missing pulses in the encoder. Closed loop control is switched to sensorless open loop control.

Troubleshooting

- Do a check of the encoder.
- Do a check of the encoder cable, cable shield, and grounding of the cable shield.
- Do a check of the mechanical mounting of the encoder.
- Do a check of the encoder parameters.

12.10.116 Fault 44 - Device changed (different type), Subcode S1 - Control board

Cause

- Option board or power unit changed.
- New device of different type or different power rating.

Troubleshooting

- Reset.
- If option board was changed, set the option board parameters again.
- If power unit was changed, set AC drive parameters again.

12.10.117 Fault 45 - Device added (different type), Subcode S1 - Control board

Cause

Option board of different type added.

Troubleshooting

- Reset.
- Set the power unit parameters again.

12.10.118 Fault 49 - Division by zero in application

Cause

Division by zero has occurred in application program.

Troubleshooting

- If the fault shows again while the AC drive is in run state, ask instructions from the local distributor.
- For an application programmer: do a check of the application program.

12.10.119 Fault 50 - Analogue input $I_{in} < 4$ mA (sel. signal range 4 to 20 mA)

Cause

Current at the analog input is < 4 mA.

- Control cable is broken or loose
- signal source has failed.

It is possible to set different responses in the application for this fault. See parameter group Protections.

Troubleshooting

Do a check of the current loop circuitry.

12.10.120 Fault 51 - External fault 1

Cause

Digital input fault.

Digital input has been programmed as external fault 1 input and this input is active.

Troubleshooting

- Check the programming.
- Check the device which the error message indicates.
- Check the cabling for the respective device.

12.10.121 Fault 52 - Keypad communication fault

Cause

The connection between the control panel (or VACON[®]NCDrive) and the drive is defective.

Troubleshooting

Do a check of the control panel connection and the control panel cable.

12.10.122 Fault 53 - Fieldbus fault

Cause

The data connection between the fieldbus master and the fieldbus board is defective.

Troubleshooting

- Do a check of the installation and fieldbus master.
- If the installation is correct, ask instructions from the local distributor.

12.10.123 Fault 54 - Slot fault

Cause

Defective option board or slot.

Troubleshooting

- Do a check of the board and slot.
- Ask instructions from the local distributor.

12.10.124 Fault 56 - Measured Temperature

Cause

Shows temperature measurement fault for option board OPTBH or OPTB8.

- Temperature exceeded set limit.
- Sensor disconnected.
- Short circuit.

Troubleshooting

Find the cause of temperature rise.

12.10.125 Fault 57 - Identification

Cause

Identification run has failed.

This fault is type A fault (Alarm).

Troubleshooting

- Run command was removed before completion of identification run.
- The motor is not connected to the AC drive.
- There is load on motor shaft.

12.10.126 Fault 58 - Brake

Cause

Actual status of the brake is different from the control signal.

It is possible to set different responses in the application for this fault. See parameter group Protections.

Troubleshooting

Do a check of the mechanical brake state and connections.

12.10.127 Fault 59 - Follower communication

Cause

SystemBus or CAN communication is broken between Master and Follower.

Troubleshooting

- Do a check of the option board parameters.
- Do a check of the optical fiber cable or CAN cable.

12.10.128 Fault 60 - Cooling

Cause

External cooling has failed.

Normally this fault comes from the heat exchanger unit.

Troubleshooting

Do a check of the reason for the failure on the external system.

12.10.129 Fault 61 - Speed error

Cause

Motor speed is unequal to reference.

Troubleshooting

- Do a check of the encoder connection.
- PMS motor has exceeded the pull-out torque.

12.10.130 Fault 62 - Run disable

Cause

Run enable signal is low.

Troubleshooting

Do a check of the reason for the Run enable signal.

12.10.131 Fault 63 - Quick stop

Cause

Command for quick stop received from digital input or fieldbus.

This fault is type A fault (Alarm).

Troubleshooting

Reset the fault.

12.10.132 Fault 64 - Input switch open

Cause

Drive input switch is open.

This fault is type A fault (Alarm)

Troubleshooting

Do a check of the main power switch of the drive.

12.10.133 Fault 65 - Measured Temperature

Cause

Shows temperature measurement fault for option board OPTBH or OPTB8.

- Temperature exceeded set limit.
- Sensor disconnected.
- Short circuit.

Troubleshooting

Find the cause of temperature rise or sensor malfunction.

12.10.134 Fault 70 - Active filter fault

Cause

Fault triggered by digital input (see param. P2.2.7.33).

It is possible to set different responses in the application for this fault. See parameter group Protections.

Troubleshooting

Remove fault situation on active filter.

12.10.135 Fault 74 - Follower fault

Cause

When using normal Master Follower function this fault code is given if one or more follower drives trips to fault.

Troubleshooting

Correct the fault cause on follower and reset fault.

Index

+	Enclosure size.....	19
+24 V control voltage output.....	Environment requirements.....	28
+24 V DC external power.....	Expander board menu.....	81
	Expander boards page.....	80
	External controller.....	16
A	F	
Accessories bag.....	Fan control.....	77
Active faults menu.....	Fault history menu.....	67
Application information.....	Fault time data record.....	66, 66
Application selection.....	Fault types.....	90
Approvals and certifications.....	Faults.....	90
Automatic parameter back-up.....	Faults, resetting of.....	90
	Fuse.....	33, 33, 33
	Fuse sizes.....	97, 98
B		
Block diagram.....		
	G	
C	Galvanic isolation barriers.....	58
Cable accessories.....	Grounding principle.....	33
Cable requirements.....		
Cable sizes.....	H	
Cable stripping.....	Hardware information.....	80
Cables, distance between.....	Hardware settings menu.....	76
Capacitors, reforming of.....	High altitude installation.....	29
Changing the rotation direction.....	High overload.....	102
Commissioning.....	HMI acknowledge timeout.....	77
Commissioning, checks after.....		
Commissioning, safety.....	I	
Control cable.....	Installation environment.....	28
Control mode.....	Installing the cables, FR4–FR6.....	42
Control mode, keypad.....	Installing the cables, FR7/FI7.....	44
Control panel.....	Installing the cables, FR8/FI8.....	48
Control terminals, OPTA1.....	Insulation checks.....	83
Control terminals, OPTA2.....	Intended use.....	16, 16
Control terminals, OPTA3.....	Internal brake resistor connection.....	77
Control unit components.....		
Cooling.....	J	
Cooling space.....	Jumper selections, OPTA1.....	55
Copy parameters.....		
Copying frequency reference set.....	K	
Covers, tightening torques.....	Keypad.....	21
	Keypad control menu.....	63
	Keypad control parameters.....	63
	Keypad reference.....	64
	Keypad settings menu.....	75
	L	
D	Language selection.....	71
DC currents.....	Lifting the product.....	26
DC link capacitance.....	Low overload.....	101
Debug menu.....		
Default page.....	M	
Derating.....	Maintenance.....	86
Digital input signal inversion.....	Menu structure.....	23
Dimensions, flange mounting FI7–FI8.....	Monitored values.....	59
Dimensions, flange mounting FR4–FR6.....	Monitoring menu.....	59
Dimensions, FI4–FI8.....	Motor overload protection.....	16
Display indications.....	Motor run checklist.....	85
Display, backlight.....		
Display, contrast.....		
Disposal.....		
Down from keypad.....		
E		
EMC class.....		
EMC-compliant installation.....		

Motor status.....	16	Software information.....	79
Multimonitoring items.....	75	Start up quick guide.....	10
O		Start-up test.....	84
Option boards.....	51, 57, 80, 81	Start-up wizard.....	74
Overload capability.....	101	Stop motor function.....	65
P		Storage.....	25
Package label.....	17	Surveillance.....	16
Parameter lock.....	74	Symbols.....	11
Parameter menu.....	60	System feedback.....	16
Parameter set, saving.....	71	System info menu.....	78
Parameter, comparing.....	73	System menu.....	68
Parameter, downloading to drive.....	72	System menu functions.....	68
Parameter, editing.....	61, 62	T	
Parameter, uploading to control panel.....	72	Technical data.....	104
Password.....	73	Terminals, FR4/F14.....	35
Power ratings.....	102, 103	Terminals, FR6/F16.....	37
Pre-charge mode parameter.....	78	Terminals, FR7/F17.....	38
Principal connection diagram.....	32	Terminals, FR8/F18.....	39
Product modified label.....	27	Terminals, tightening torques.....	101
Q		Timeout time.....	76
Qualified personnel.....	9	Total counters.....	78
R		Trip counters.....	79
Remote commands.....	16	Type code.....	18
Resetting fault history.....	67	U	
RUN test.....	84	UL certification.....	9
S		UL requirements, cables.....	33
Safety.....	11, 12	Up to keypad.....	72
Security menu.....	73	V	
Service Info file.....	90	Vibration and shock.....	28
Sine filter parameter.....	78	W	
		Weight.....	92

ENGINEERING
TOMORROW



Danfoss A/S
Nordborgvej 81
DK-6430 Nordborg
www.danfoss.com

.....
Danfoss can accept no responsibility for possible errors in catalogues, brochures and other printed material. Danfoss reserves the right to alter its products without notice. This also applies to products already on order provided that such alterations can be made without subsequential changes being necessary in specifications already agreed. All trademarks in this material are property of the respective companies. Danfoss and the Danfoss logotype are trademarks of Danfoss A/S. All rights reserved.
.....



* D P D 0 0 9 0 8 *



* D P D 0 0 9 0 8 E 0 1 *