

Multiwire Kit for Fx09-Fx10

iC7 Series Frequency Converters

1 Overview

1.1 Description

The multiwire kit enables the connection of 3 wires to a single terminal in iC7 Series Fx09–Fx10 Frequency Converters. The kit includes parts for making multiwire connections to 3 mains terminals and 3 motor terminals.

See [Table 1](#) for the maximum number of cables per phase and maximum cable size when using the multiwire kit. Refer to the design guide for other power cable specifications.

Table 1: Maximum Number and Size of Cables for Multiwire Kit Connections

Frame	Maximum number of cables per phase and maximum cable cross-section [mm ² (AWG)]
Fx09	3x70 (3x2/0)
Fx10	3x150 (3x300 MCM)

1.2 Kit Number

Table 2: Multiwire Kit Number

Number	Description
176F4189	Fx09–Fx10 multi wire kit

1.3 Items Supplied

Table 3: Contents of Multiwire Kit for iC7 Series Fx09–Fx10 Frequency Converters

Item	Quantity
Hex screw M10x60	6
Washer M10	6
Spacer	6

2 Installation

2.1 Safety Information

NOTICE

QUALIFIED PERSONNEL

Only qualified personnel are allowed to install the parts described in these installation instructions.

- Disassembly and reassembly of the frequency converter must be done in accordance with the corresponding service guide.
- Use the standard fastener torque values from the service guide, unless the torque value is specified in these instructions.

⚠ WARNING ⚠

ELECTRICAL SHOCK HAZARD

The frequency converter contains dangerous voltages when connected to mains voltage. Improper installation, and installing or servicing with power connected, can cause death, serious injury, or equipment failure.

- Only use qualified electricians for the installation.
- Disconnect the frequency converter from all power sources before installation or service.
- Treat the frequency converter as live whenever the mains voltage is connected.
- Follow the guidelines in these instructions and local electrical safety codes.

⚠ WARNING ⚠

DISCHARGE TIME (20 MINUTES)

The frequency converter contains DC-link capacitors, which can remain charged even when the frequency converter is not powered. High voltage can be present even when the warning indicator lights are off.

Failure to wait 20 minutes after power has been removed before performing service or repair work can result in death or serious injury.

- Stop the motor.
- Disconnect AC mains, permanent magnet type motors, and remote DC-link supplies, including battery back-ups, UPS, and DC-link connections to other frequency converters.
- Wait 20 minutes for the capacitors to discharge fully before performing any service or repair work.
- Measure the voltage level to verify full discharge.

NOTICE

ELECTROSTATIC DISCHARGE

Electrostatic discharge can damage components.

- Ensure discharge before touching internal frequency converter components, for example by touching a grounded, conductive surface or by wearing a grounded armband.

2.2 Installing the Multiwire Kit

To install the multiwire kit, use the following steps.

Procedure

1. Disconnect any existing customer wiring.
2. Install the 1st cable:
 - a. Attach the lug to the cable.
 - b. Position the lug underneath the terminal busbar, between the busbar and the plastic terminal block.

See [Illustration 1](#).

- c. Align the hole in the lug with the hole in the terminal busbar.
- d. Check that the lug is in contact with the busbar.
- e. Tighten the cable gland.

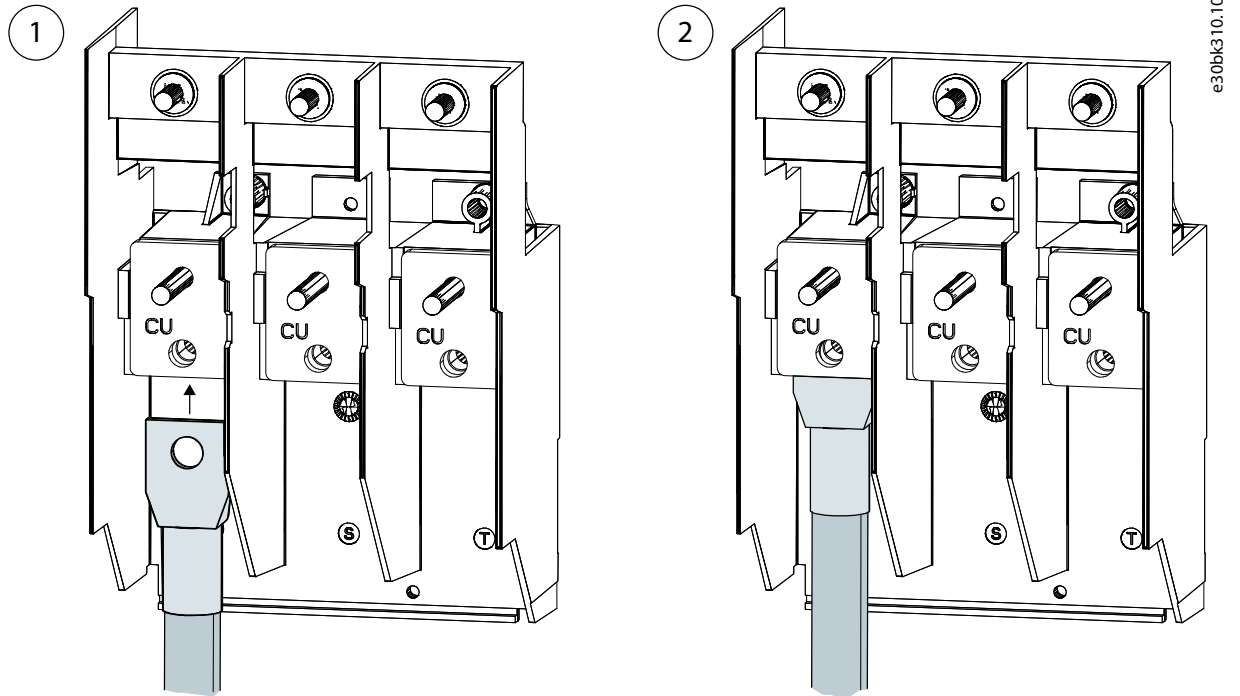

Illustration 1: Installation of 1st Cable

3. Install the 2nd cable:
- a. Attach the lug to the cable.
 - b. Position the lug on top of the terminal busbar.

See [Illustration 2](#).

- c. Align the hole in the lug with the hole in the terminal busbar.
-

- d. Tighten the cable gland.

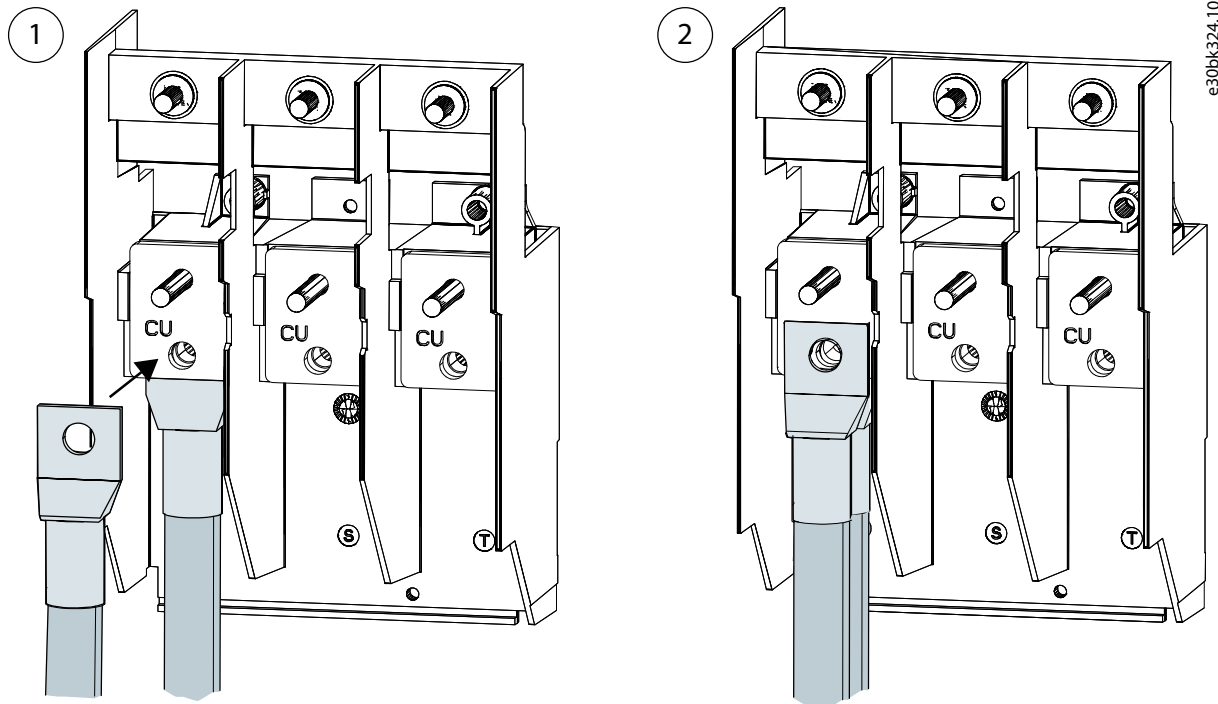

Illustration 2: Installation of 2nd Cable

4. Install the 3rd cable:

- a. Attach the lug to the cable.
- b. Using 1 M10x60 screw, place 1 M10 washer, the 3rd lug, and 1 spacer onto the screw.

Place the items on the screw in the order listed. Check that the washer is on top of the lug, and the spacer is below the lug. See [Illustration 3](#).

- c. Guide the assembled screw through the holes in the 2nd lug, the terminal busbar, and the 1st lug.
- d. Tighten the screw.
-

- e. Tighten the cable gland.

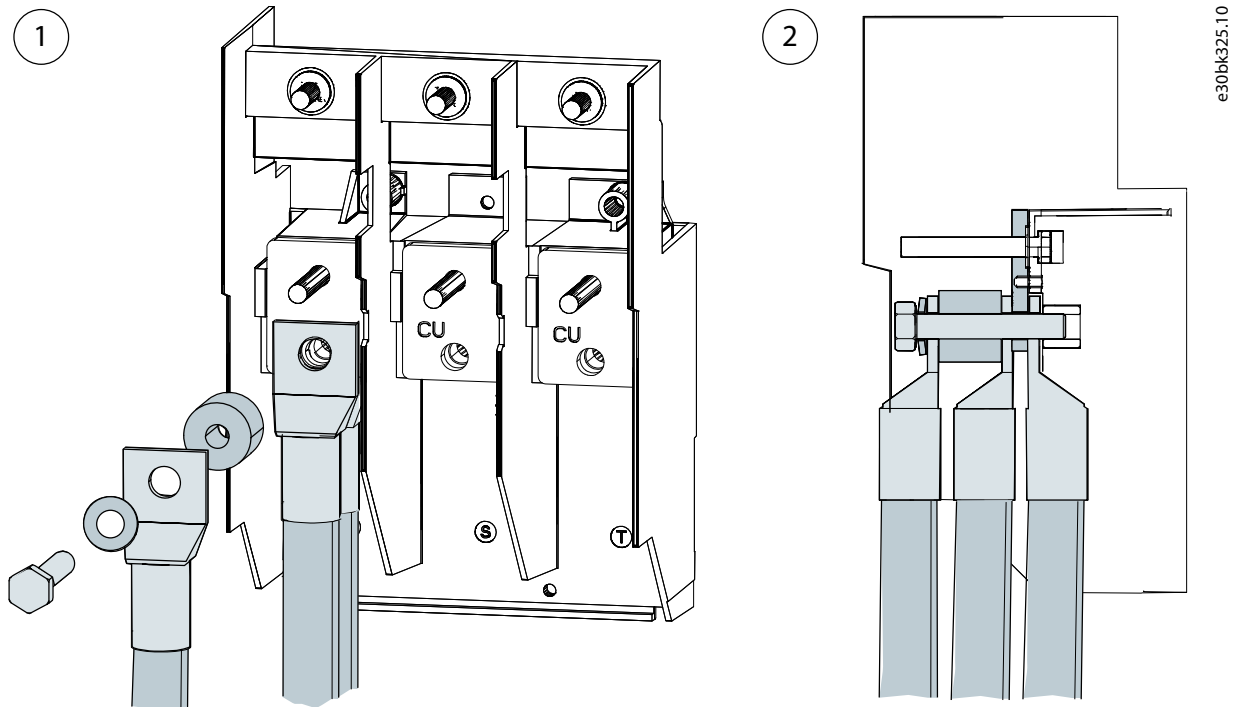

Illustration 3: Installation of 3rd Cable and Cross Section View

5. Repeat steps 1–4 for each mains and motor terminal.

Torque all to 19 Nm (168 in-lb).

Danfoss A/S
Nordborgvej 81
DK-6430 Nordborg
www.danfoss.com

.....
Danfoss can accept no responsibility for possible errors in catalogues, brochures and other printed material. Danfoss reserves the right to alter its products without notice. This also applies to products already on order provided that such alterations can be made without subsequential changes being necessary in specifications already agreed. All trademarks in this material are property of the respective companies. Danfoss and the Danfoss logotype are trademarks of Danfoss A/S. All rights reserved.
.....

