



Operating Instructions

VLT[®] Extended Relay Card MCB 113

VLT[®] AutomationDrive FC 300

Contents

| | |
|--|-----------|
| 1 How to Read these Operating Instructions | 3 |
| Approvals | 3 |
| Symbols | 3 |
| Abbreviations | 4 |
| 2 Safety and Conformity | 5 |
| 3 Introduction to Extended Relay Card MCB 113 | 7 |
| Connection Schematic | 7 |
| Connection Schematic - Following NAMUR | 8 |
| Galvanic Isolation | 9 |
| Electrical Data | 9 |
| Ordering Numbers | 9 |
| 4 How to Install | 11 |
| Installation of Option in the Frequency Converter | 11 |
| 5 Parameter Set-up | 13 |
| 5-** Digital In/Out | 13 |
| 6-** Analog Outputs | 25 |
| 14-** 24 V DC External Supply | 27 |
| 16-** Data readouts | 28 |



1

1 How to Read these Operating Instructions

These Operating Instructions will help you get started, install and program your VLT Extended Relay Card MCB 113.

Chapter 1, **How to Read these Operating Instructions**, introduces the manual and informs you about the approvals, symbols, and abbreviations used in this literature.

Chapter 2, **Safety and Conformity**, contains safety instructions for the option card and the VLT AutomationDrive FC 300.

Chapter 3, **Introduction to VLT Extended Relay Card MCB 113**, informs about the MCB 113 option card, the electrical connections and electrical data.

Chapter 4, **How to Install**, explains how to install the option card.

Chapter 5, **Parameter Set-up**, shows the parameter settings associated with the VLT Extended Relay Card MCB 113.

1.1.1 Approvals



1.1.2 Symbols

Symbols used in this Operating Instructions.

| | |
|--|--|
| | NB! Indicates something to be noted by the reader. |
|--|--|

| | |
|--|------------------------------|
| | Indicates a general warning. |
|--|------------------------------|

| | |
|--|-----------------------------------|
| | Indicates a high-voltage warning. |
|--|-----------------------------------|

| | |
|---|---------------------------|
| * | Indicates default setting |
|---|---------------------------|

1

1.1.3 Abbreviations

| | |
|-------------------------------|--|
| SPDT | Single Pull Double Throw (Relay) |
| NAMUR NE37 | German recommendations, commonly used within the Chemical Industry "Realisation of Frequency Converters Standard Terminal Strip for Variable-speed Drives" |
| Ampere/AMP | A |
| Alternating current | AC |
| Direct current | DC |
| Electromagnetic Compatibility | EMC |
| Hertz | Hz |
| Parameter | par. |
| Volts | V |
| Mili | m |

2 Safety and Conformity

2.1 Safety Precautions

2.1.1 Safety Precautions

2



The voltage of the frequency converter is dangerous whenever connected to mains. Incorrect installation of the motor, frequency converter or fieldbus may cause death, serious personal injury or damage to the equipment. Consequently, the instructions in this manual, as well as national and local rules and safety regulations, must be complied with.

Safety Regulations

1. The mains supply to the frequency converter must be disconnected whenever repair work is to be carried out. Check that the mains supply has been disconnected and that the necessary time has elapsed before removing motor and mains supply plugs.
2. The [OFF] button on the control panel of the frequency converter does not disconnect the mains supply and consequently it must not be used as a safety switch.
3. The equipment must be properly earthed, the user must be protected against supply voltage and the motor must be protected against overload in accordance with applicable national and local regulations.
4. The earth leakage current exceeds 3.5 mA.
5. Protection against motor overload is not included in the factory setting. If this function is desired, set par. 1-90 *Motor Thermal Protection* to data value ETR trip 1 [4] or data value ETR warning 1 [3].
6. Do not remove the plugs for the motor and mains supply while the frequency converter is connected to mains. Check that the mains supply has been disconnected and that the necessary time has elapsed before removing motor and mains plugs.
7. Please note that the frequency converter has more voltage sources than L1, L2 and L3, when load sharing (linking of DC intermediate circuit) or external 24 V DC are installed. Check that all voltage sources have been disconnected and that the necessary time has elapsed before commencing repair work.

Warning against unintended start

1. The motor can be brought to a stop by means of digital commands, bus commands, references or a local stop, while the frequency converter is connected to mains. If personal safety considerations (e.g. risk of personal injury caused by contact with moving machine parts following an unintentional start) make it necessary to ensure that no unintended start occurs, these stop functions are not sufficient. In such cases the mains supply must be disconnected or the *Safe Stop* function must be activated.
2. The motor may start while setting the parameters. If this means that personal safety may be compromised (e.g. personal injury caused by contact with moving machine parts), motor starting must be prevented, for instance by use of the *Safe Stop* function or secure disconnection of the motor connection.
3. A motor that has been stopped with the mains supply connected, may start if faults occur in the electronics of the frequency converter, through temporary overload or if a fault in the power supply grid or motor connection is remedied. If unintended start must be prevented for personal safety reasons (e.g. risk of injury caused by contact with moving machine parts), the normal stop functions of the frequency converter are not sufficient. In such cases the mains supply must be disconnected or the *Safe Stop* function must be activated.



NB!

When using the *Safe Stop* function, always follow the instructions in the *Safe Stop* section of the VLT AutomationDrive Design Guide.

4. Control signals from, or internally within, the frequency converter may in rare cases be activated in error, be delayed or fail to occur entirely. When used in situations where safety is critical, e.g. when controlling the electromagnetic brake function of a hoist application, these control signals must not be relied on exclusively.



Touching the electrical parts may be fatal - even after the equipment has been disconnected from mains. Also make sure that other voltage inputs have been disconnected, such as external 24 V DC, load sharing (linkage of DC intermediate circuit), as well as the motor connection for kinetic back up. Systems where frequency converters are installed must, if necessary, be equipped with additional monitoring and protective devices according to the valid safety regulations, e.g. law on mechanical tools, regulations for the prevention of accidents etc. Modifications on the frequency converters by means of the operating software are allowed.



NB!
Hazardous situations shall be identified by the machine builder/ integrator who is responsible for taking necessary preventive means into consideration. Additional monitoring and protective devices may be included, always according to valid national safety regulations, e.g. law on mechanical tools, regulations for the prevention of accidents.



NB!
Crane, Lifts and Hoists:
The controlling of external brakes must always have a redundant system. The frequency converter can in no circumstances be the primary safety circuit. Comply with relevant standards, e.g.
Hoists and cranes: IEC 60204-32
Lifts: EN 81

Protection Mode

Once a hardware limit on motor current or dc-link voltage is exceeded the frequency converter will enter "Protection mode". "Protection mode" means a change of the PWM modulation strategy and a low switching frequency to minimize losses. This continues 10 sec after the last fault and increases the reliability and the robustness of the frequency converter while re-establishing full control of the motor.

In hoist applications "Protection mode" is not usable because the frequency converter will usually not be able to leave this mode again and therefore it will extend the time before activating the brake – which is not recommendable.

The "Protection mode" can be disabled by setting par. 14-26 *Trip Delay at Inverter Fault* to zero which means that the frequency converter will trip immediately if one of the hardware limits is exceeded.



NB!
It is recommended to disable protection mode in hoisting applications (par. 14-26 *Trip Delay at Inverter Fault* = 0)



The DC link capacitors remain charged after power has been disconnected. To avoid electrical shock hazard, disconnect the frequency converter from mains before carrying out maintenance. When using a PM-motor, make sure it is disconnected. Before doing service on the frequency converter wait at least the amount of time indicated below:

| Voltage | Power | Waiting Time |
|-------------|-------------------------------|--------------|
| 380 - 500 V | 0.25 - 7.5 kW | 4 minutes |
| | 11 - 75 kW | 15 minutes |
| | 90 - 200 kW | 20 minutes |
| 525 - 690 V | 250 - 800 kW | 40 minutes |
| | 11-75 kW (frame size B and C) | 15 minutes |
| | 37 - 315 kW (frame size D) | 20 minutes |
| | 355 - 1000 kW | 30 minutes |

For further information, please see the VLT Automation Drive FC 300 Operating Instructions, MG.33.AX.YY or the VLT Automation Drive FC 300 Design Guide, MG.33.BX.YY

x = version number
y = language

3 Introduction to Extended Relay Card MCB 113

The VLT Extended Relay Card MCB 113 is constructed as a standard C1 option for the Danfoss VLT AutomationDrive FC 300 and is automatically detected after mounting.

The MCB 113 adds 7 digital inputs, 2 analog outputs and 4 SPDT relays to the standard I/O of the frequency converter which makes it possible to comply with the German NAMUR NE37 recommendations.

3

3.1.1 Connection Schematic

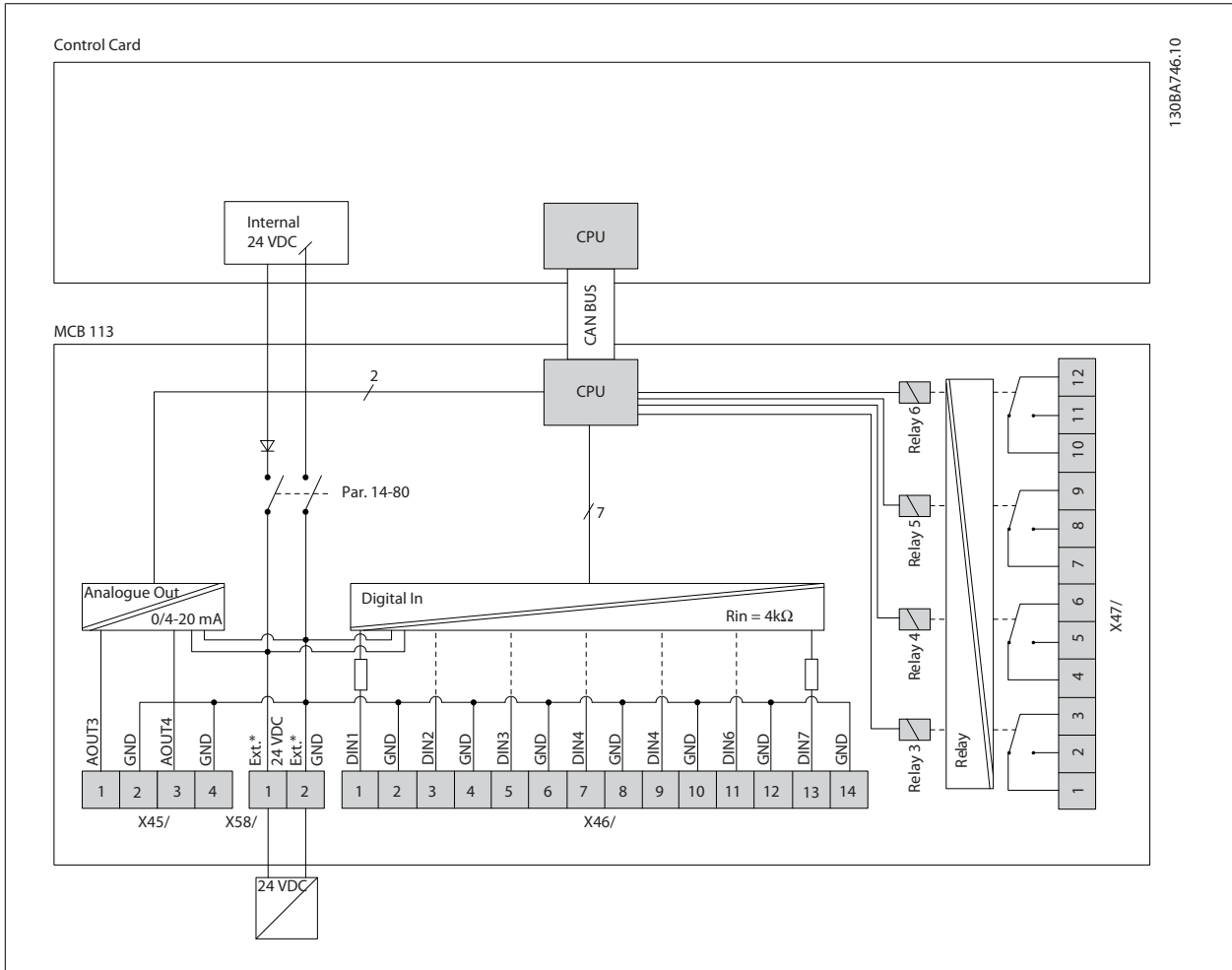

NB!
 The connection of these relays is different than for the standard relays of the FC 300. The coil is between T2 and T3 instead of between T1 and T2.

3

Digital inputs are programmed for either PNP or NPN in par. 5-00 *Digital I/O Mode*

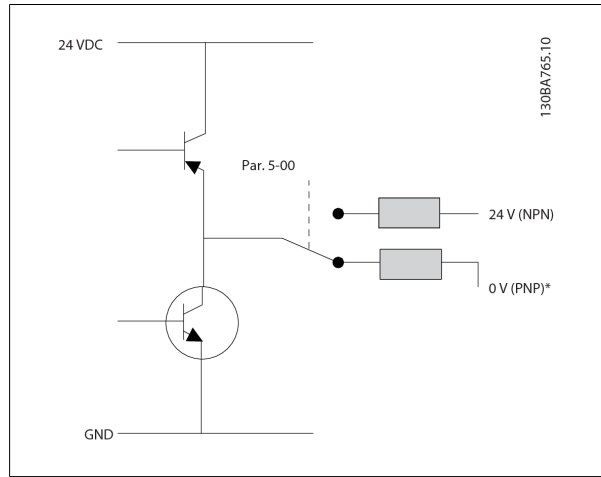

3.1.2 Connection Schematic - Following NAMUR

In NAMUR terminology.

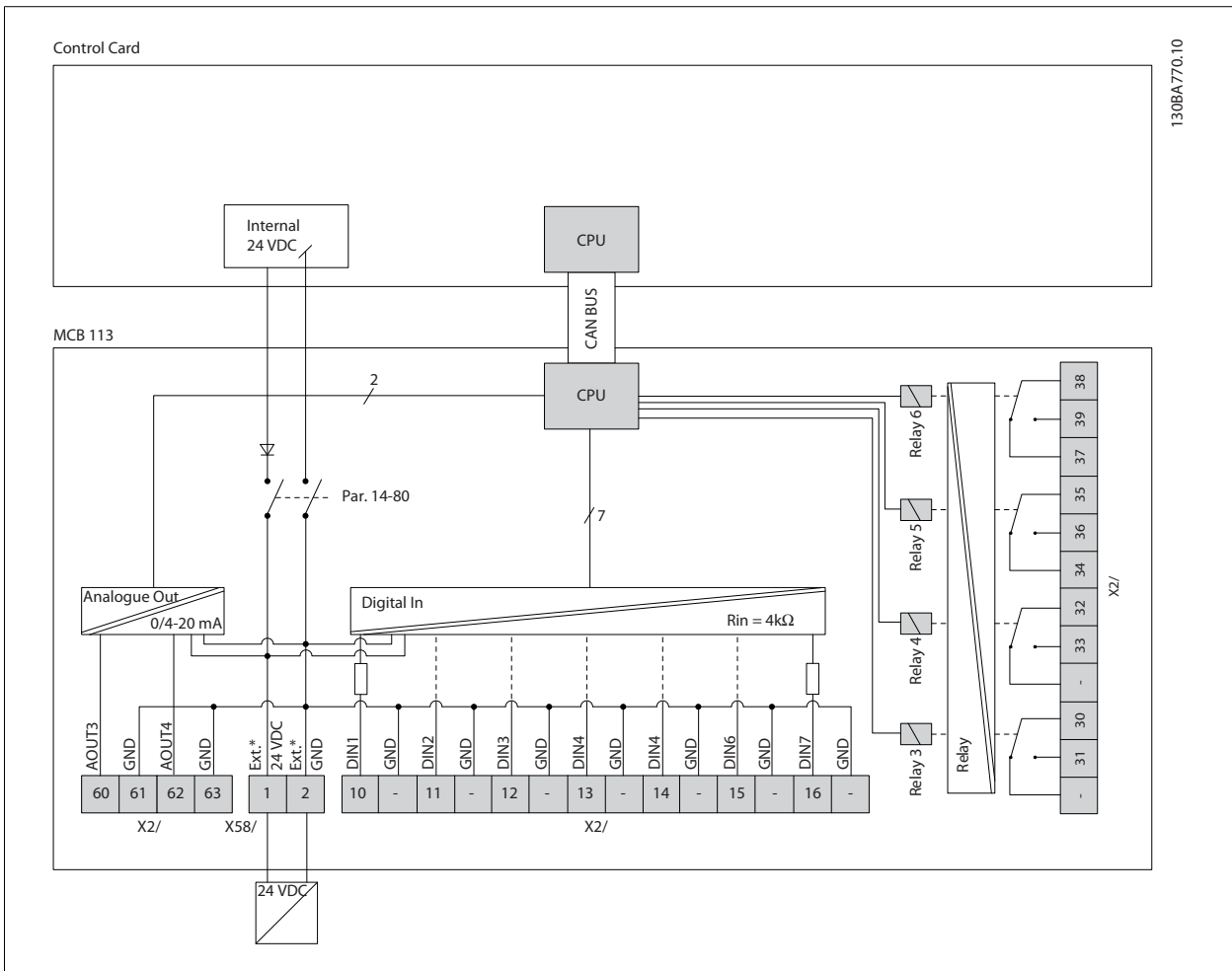

3.1.3 Galvanic Isolation

MCB 113 can be connected to an external 24 V on X58/ in order to ensure galvanic isolation between the VLT AutomationDrive and the option card. If galvanic isolation is not needed, the option card can be supplied through internal 24 V from the frequency converter - available on X58/ provided that internal supply is specified in par. 14-80 *Option Supplied by External 24VDC* ([0] No).

The relays support a combination of 24 V and 250 V signals as long as there is an unused relay in-between.

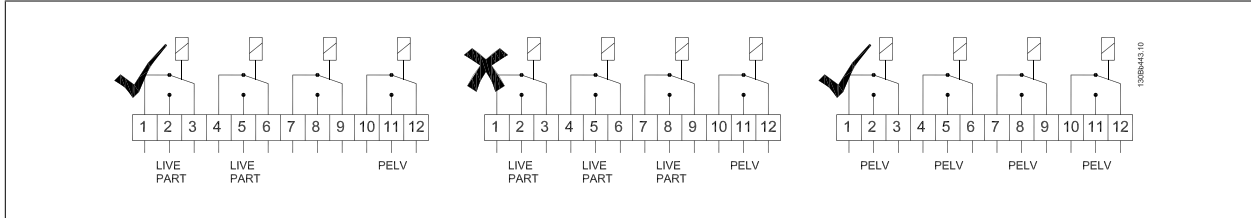

3.1.4 Electrical Data

Relays:

| | |
|--|---|
| Number | 4 SPDT |
| Load at 250 V AC / 30 V DC | 8 A |
| Load at 250 V AC / 30 V DC with $\cos \varphi = 0.4$ | 3.5 A |
| Overvoltage category (contact-earth) | III |
| Overvoltage category (contact-contact) | II |
| Combination of 250 V and 24 V signals | Possible with one unused relay in-between |

Digital Inputs:

| | |
|--------------------|--------------|
| Number | 7 |
| Range | 0/24 V |
| Mode | PNP/NPN |
| Input impedance | 4 k Ω |
| Low trigger level | 6.4 V |
| High trigger level | 17 V |

Analog Outputs:

| | |
|------------|------------|
| Number | 2 |
| Range | 0/4 -20 mA |
| Resolution | 11 bit |
| Linearity | < 0.2% |

EMC

| | |
|-----|--|
| EMC | IEC 61000-6-2 and IEC 61800-3 regarding Immunity of BURST, ESD, SURGE and Conducted Immunity |
|-----|--|

3.1.5 Ordering Numbers

130B1164 (Non-coated)

130B1264 (Coated)

4

4 How to Install

4.1.1 Installation of Option in the Frequency Converter



NB!
Before start, interrupt the power supply to the frequency converter. Never install an option card into the frequency converter during operation.

The VLT Extended Relay Card MCB 113 option is exclusively intended for use in option slot C1.

When ordered with the drive, the option is installed from factory. For retrofit, a mounting kit must be purchased. The mounting kit includes a fan for MCO 305 and is only to be mounted if MCO 305 is used.

| Mounting kit depending on frame | Order no. |
|--------------------------------------|-----------|
| Bookstyle | |
| A2 and A3 (40 mm for one C option) | 130B7530 |
| A2 and A3 (60 mm for C0 + C1 option) | 130B7531 |
| B3 (40 mm for one C option) | 130B1413 |
| B3 (60 mm for C0 + C1 option) | 130B1414 |
| Compact | |
| A5 | 130B7532 |
| B, C, D, E and F (except B3) | 130B7533 |



NB!
Do not mount the small fan for MCB 113, MCF 106 or frame sizes B4, C3, C4, D, E & F

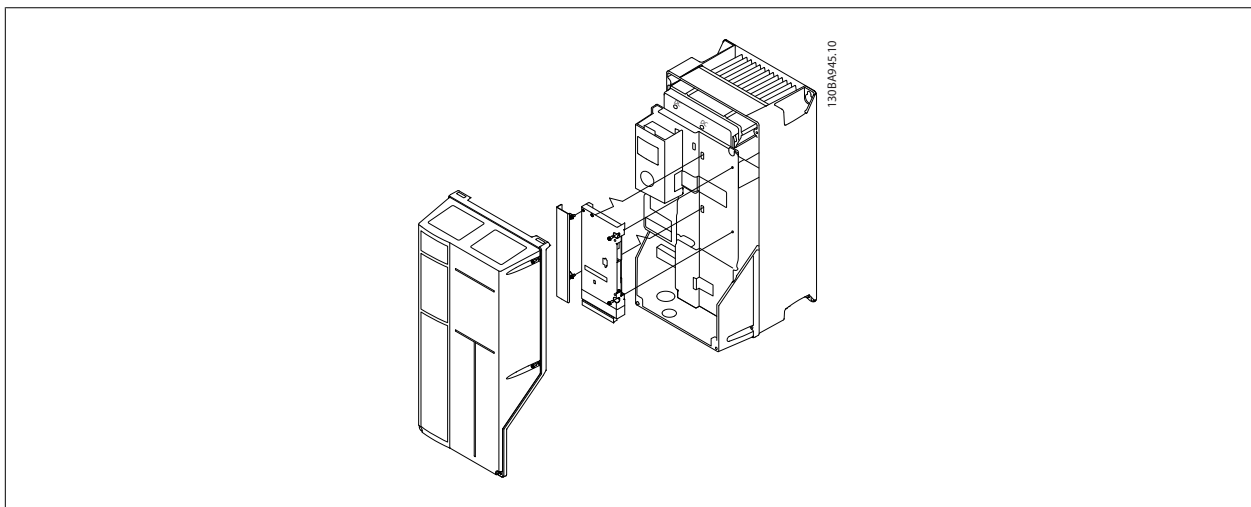

Enclosure A5 - C

For these enclosures only one C option can be installed at a time.

4

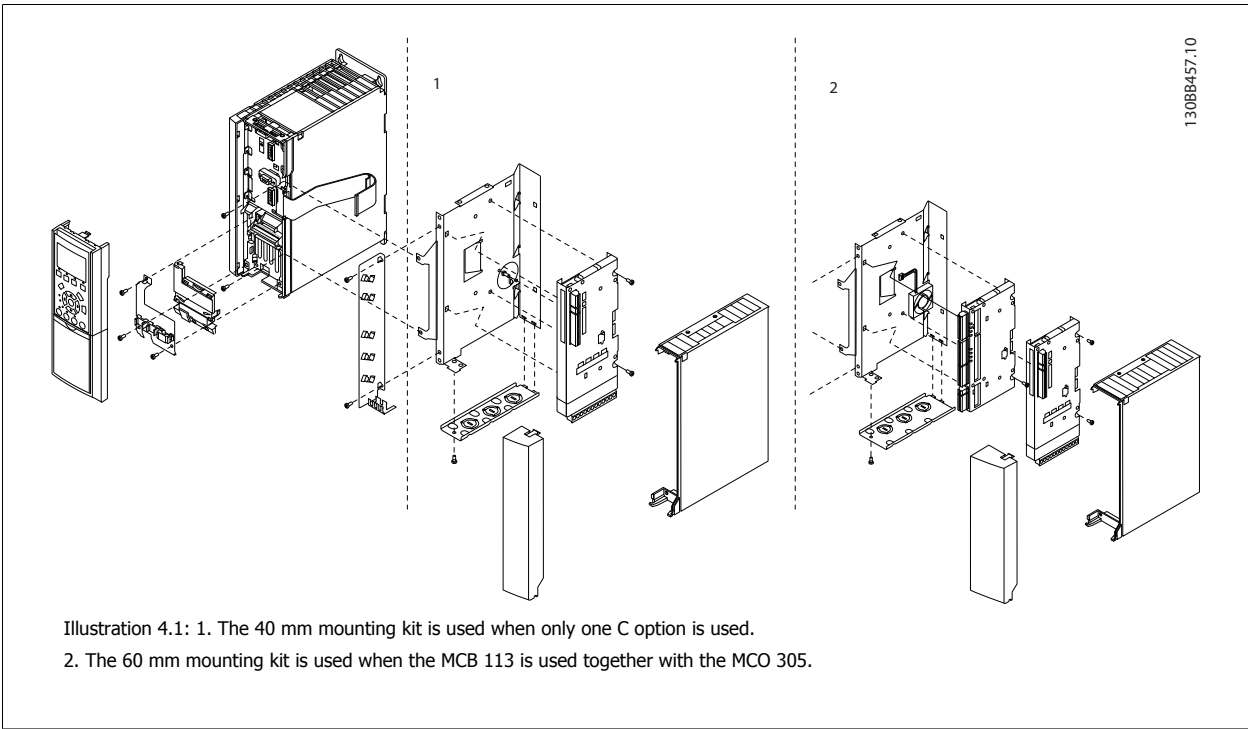

Illustration 4.1: 1. The 40 mm mounting kit is used when only one C option is used.
 2. The 60 mm mounting kit is used when the MCB 113 is used together with the MCO 305.

5 Parameter Set-up

The parameters included in these Operating Instructions are additional parameters for the FC 300 Programming Guide MG.33.MX.YY

5.2 5-** Digital In/Out

5.2.1 5-1* Digital Inputs

Parameters for configuring the input functions for the input terminals.

The digital inputs are used for selecting various functions in the frequency converter. All digital inputs can be set to the following functions:

| Digital input function | Select | Terminal |
|------------------------------|--------|------------------|
| No operation | [0] | All *term 32, 33 |
| Reset | [1] | All |
| Coast inverse | [2] | All *term 27 |
| Coast and reset inverse | [3] | All |
| Quick stop inverse | [4] | All |
| DC-brake inverse | [5] | All |
| Stop inverse | [6] | All |
| Start | [8] | All *term 18 |
| Latched start | [9] | All |
| Reversing | [10] | All *term 19 |
| Start reversing | [11] | All |
| Enable start forward | [12] | All |
| Enable start reverse | [13] | All |
| Jog | [14] | All *term 29 |
| Preset reference on | [15] | All |
| Preset ref bit 0 | [16] | All |
| Preset ref bit 1 | [17] | All |
| Preset ref bit 2 | [18] | All |
| Freeze reference | [19] | All |
| Freeze output | [20] | All |
| Speed up | [21] | All |
| Speed down | [22] | All |
| Set-up select bit 0 | [23] | All |
| Set-up select bit 1 | [24] | All |
| Precise stop inverse | [26] | 18, 19 |
| Precises start, stop | [27] | 18, 19 |
| Catch up | [28] | All |
| Slow down | [29] | All |
| Counter input | [30] | 29, 33 |
| Pulse input Edge Triggered | [31] | 29, 33 |
| Pulse input Time Based | [32] | 29, 33 |
| Ramp bit 0 | [34] | All |
| Ramp bit 1 | [35] | All |
| Mains failure inverse | [36] | All |
| Latched precise start | [40] | 18, 19 |
| Latched precise stop inverse | [41] | 18, 19 |
| DigiPot Increase | [55] | All |
| DigiPot Decrease | [56] | All |
| DigiPot Clear | [57] | All |
| Digipot Hoist | [58] | All |
| Counter A (up) | [60] | 29, 33 |
| Counter A (down) | [61] | 29, 33 |
| Reset Counter A | [62] | All |
| Counter B (up) | [63] | 29, 33 |
| Counter B (down) | [64] | 29, 33 |
| Reset Counter B | [65] | All |
| Mech. Brake Feedb. | [70] | All |
| Mech. Brake Feedb. Inv. | [71] | All |
| PID Error Inv. | [72] | All |
| PID Reset I-part | [73] | All |
| PID enable | [74] | All |
| PTC Card 1 | [80] | All |

FC 300 standard terminals are 18, 19, 27, 29, 32 and 33. MCB 101 terminals are X30/2, X30/3 and X30/4.

Terminal 29 functions as an output only in FC 302.

Functions dedicated to only one digital input are stated in the associated parameter.

All digital inputs can be programmed to these functions:

| | | |
|---|-------------------------|--|
| [0] | No operation | No reaction to signals transmitted to the terminal. |
| [1] | Reset | Resets frequency converter after a TRIP/ALARM. Not all alarms can be reset. |
| [2] | Coast inverse | (Default Digital input 27): Coasting stop, inverted input (NC). The frequency converter leaves the motor in free mode. Logic '0' => coasting stop. |
| [3] | Coast and reset inverse | Reset and coasting stop Inverted input (NC). Leaves motor in free mode and resets frequency converter. Logic '0' => coasting stop and reset. |
| [4] | Quick stop inverse | Inverted input (NC). Generates a stop in accordance with quick-stop ramp time set in par. 3-81 <i>Quick Stop Ramp Time</i> . When motor stops, the shaft is in free mode. Logic '0' => Quick-stop. |
| [5] | DC-brake inverse | Inverted input for DC braking (NC). Stops motor by energizing it with a DC current for a certain time period. See par. 2-01 <i>DC Brake Current</i> to par. 2-03 <i>DC Brake Cut In Speed [RPM]</i> . The function is only active when the value in par. 2-02 <i>DC Braking Time</i> is different from 0. Logic '0' => DC braking. |
| [6] | Stop inverse | Stop Inverted function. Generates a stop function when the selected terminal goes from logical level '1' to '0'. The stop is performed according to the selected ramp time (par. 3-42 <i>Ramp 1 Ramp Down Time</i> , par. 3-52 <i>Ramp 2 Ramp down Time</i> , par. 3-62 <i>Ramp 3 Ramp down Time</i> , par. 3-72 <i>Ramp 4 Ramp Down Time</i>). |
| <div style="border: 1px solid black; padding: 5px;">  <p>NB! When the frequency converter is at the torque limit and has received a stop command, it may not stop by itself. To ensure that the frequency converter stops, configure a digital output to <i>Torque limit & stop [27]</i> and connect this digital output to a digital input that is configured as coast.</p> </div> | | |
| [8] | Start | (Default Digital input 18): Select start for a start/stop command. Logic '1' = start, logic '0' = stop. |
| [9] | Latched start | The motor starts, if a pulse is applied for min. 2 ms. The motor stops when Stop inverse is activated. |
| [10] | Reversing | (Default Digital input 19). Change the direction of motor shaft rotation. Select Logic '1' to reverse. The reversing signal only changes the direction of rotation. It does not activate the start function. Select both directions in par. 4-10 <i>Motor Speed Direction</i> . The function is not active in process closed loop. |
| [11] | Start reversing | Used for start/stop and for reversing on the same wire. Signals on start are not allowed at the same time. |
| [12] | Enable start forward | Disengages the counterclockwise movement and allows for the clockwise direction. |
| [13] | Enable start reverse | Disengages the clockwise movement and allows for the counterclockwise direction. |
| [14] | Jog | (Default Digital input 29): Use to activate jog speed. See par. 3-11 <i>Jog Speed [Hz]</i> . |
| [15] | Preset reference on | Shifts between external reference and preset reference. It is assumed that <i>External/preset [1]</i> has been selected in par. 3-04 <i>Reference Function</i> . Logic '0' = external reference active; logic '1' = one of the eight preset references is active. |
| [16] | Preset ref bit 0 | Preset ref. bit 0,1, and 2 enables a choice between one of the eight preset references according to the table below. |
| [17] | Preset ref bit 1 | Same as Preset ref bit 0 [16]. |
| [18] | Preset ref bit 2 | Same as Preset ref bit 0 [16]. |

| Preset ref. bit | 2 | 1 | 0 |
|-----------------|---|---|---|
| Preset ref. 0 | 0 | 0 | 0 |
| Preset ref. 1 | 0 | 0 | 1 |
| Preset ref. 2 | 0 | 1 | 0 |
| Preset ref. 3 | 0 | 1 | 1 |
| Preset ref. 4 | 1 | 0 | 0 |
| Preset ref. 5 | 1 | 0 | 1 |
| Preset ref. 6 | 1 | 1 | 0 |
| Preset ref. 7 | 1 | 1 | 1 |

| | | |
|------|------------|---|
| [19] | Freeze ref | Freezes the actual reference, which is now the point of enable/condition for Speed up and Speed down to be used. If Speed up/down is used, the speed change always follows ramp 2 |
|------|------------|---|

(par. 3-51 *Ramp 2 Ramp up Time* and par. 3-52 *Ramp 2 Ramp down Time*) in the range 0 - par. 3-03 *Maximum Reference*.

[20] Freeze output

Freezes the actual motor frequency (Hz), which is now the point of enable/condition for Speed up and Speed down to be used. If Speed up/down is used, the speed change always follows ramp 2 (par. 3-51 *Ramp 2 Ramp up Time* and par. 3-52 *Ramp 2 Ramp down Time*) in the range 0 - par. 1-23 *Motor Frequency*.

NB!
When Freeze output is active, the frequency converter cannot be stopped via a low 'start [8]' signal. Stop the frequency converter via a terminal programmed for Coasting inverse [2] or Coast and reset, inverse.

[21] Speed up

Select Speed up and Speed down if digital control of the up/down speed is desired (motor potentiometer). Activate this function by selecting either Freeze reference or Freeze output. When Speed up/ down is activated for less than 400 msec. the resulting reference will be increased/ decreased by 0.1 %. If Speed up/ down is activated for more than 400 msec. the resulting reference will follow the setting in ramping up/ down parameter 3-x1/ 3-x2.

| | Shut down | Catch up |
|----------------------|-----------|----------|
| Unchanged speed | 0 | 0 |
| Reduced by %-value | 1 | 0 |
| Increased by %-value | 0 | 1 |
| Reduced by %-value | 1 | 1 |

[22] Speed down Same as Speed up [21].

[23] Set-up select bit 0 Select Set-up select bit 0 or Select Set-up select bit 1 to select one of the four set-ups. Set par. 0-10 *Active Set-up* to Multi Set-up.

[24] Set-up select bit 1 (Default Digital input 32): Same as Set-up select bit 0 [23].

[26] Precise stop inv. Prolongs stop signal to give a precise stop independent of speed.

Sends an inverted stop signal when the precise stop function is activated in par. 1-83 *Precise Stop Function*.

Precise stop inverse function is available for terminals 18 or 19.

[27] Precise start, stop

Use when Precise ramp stop [0] is selected in par. 1-83 *Precise Stop Function*.

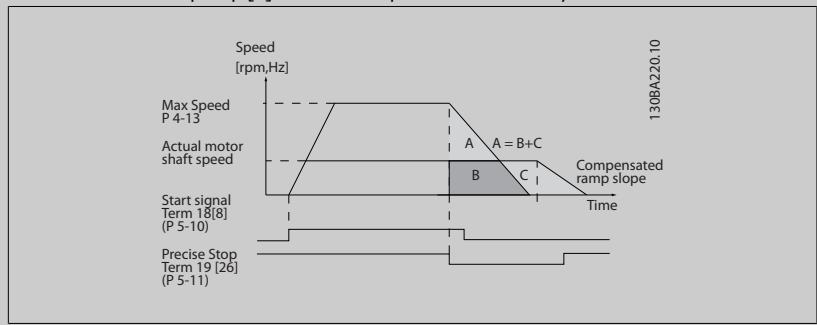

[28] Catch up Increases reference value by percentage (relative) set in par. 3-12 *Catch up/slow Down Value*.

[29] Slow down Reduces reference value by percentage (relative) set in par. 3-12 *Catch up/slow Down Value*.

[30] Counter input Precise stop function in par. 1-83 *Precise Stop Function* acts as Counter stop or speed compensated counter stop with or without reset. The counter value must be set in par. 1-84 *Precise Stop Counter Value*.

[31] Pulse edge triggered Edge triggered pulse input counts number of pulse flanks per sample time. This gives a higher resolution at high frequencies, but is not as precise at lower frequencies. Use this pulse principle for encoders with very low resolution (e.g. 30 ppr).

5

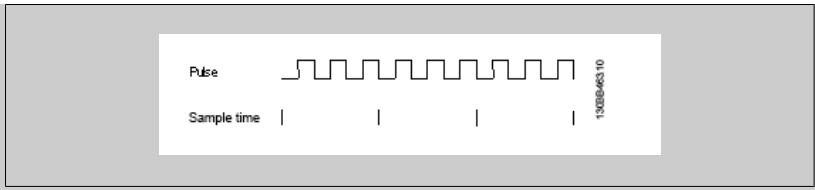

[32] Pulse time based Time based pulse input measures the duration between flanks. This gives a higher resolution at lower frequencies, but is not as precise at higher frequencies. This principle has a cut-off frequency which makes it unsuited for encoders with very low resolutions (e.g. 30 ppr) at low speeds.

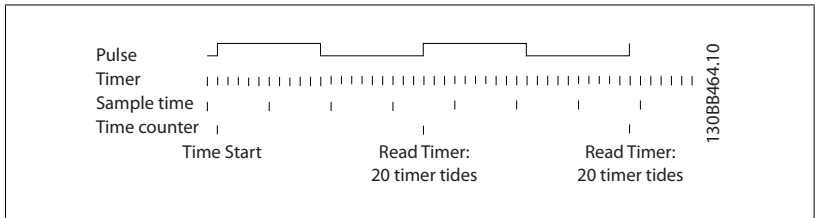
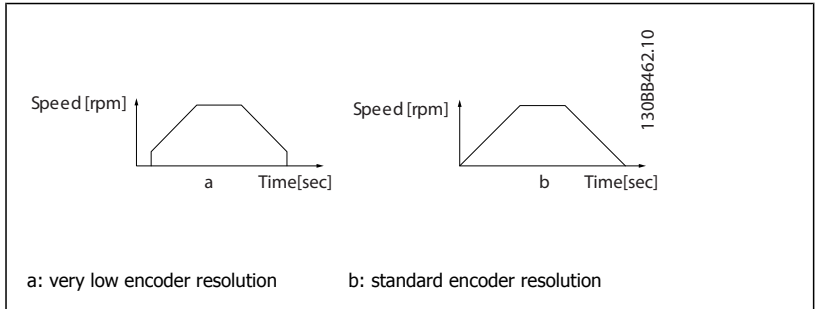

[34] Ramp bit 0 Enables a choice between one of the 4 ramps available, according to the table below.
 [35] Ramp bit 1 Same as Ramp bit 0.

| | | |
|-----------------|---|---|
| Preset ramp bit | 1 | 0 |
| Ramp 1 | 0 | 0 |
| Ramp 2 | 0 | 1 |
| Ramp 3 | 1 | 0 |
| Ramp 4 | 1 | 1 |

- [36] Mains failure inverse Activates par. 14-10 *Mains Failure*. Mains failure inverse is active in the Logic .0. situation.
- [41] Latched Precise Stop inverse Sends a latched stop signal when the precise stop function is activated in par. 1-83 *Precise Stop Function*. The Latched Precise stop inverse function is available for terminals 18 or 19.
- [55] DigiPot Increase INCREASE signal to the Digital Potentiometer function described in par. group 3-9*
- [56] DigiPot Decrease DECREASE signal to the Digital Potentiometer function described in par. group 3-9*
- [57] DigiPot Clear Clears the Digital Potentiometer reference described in par. group 3-9*
- [60] Counter A (Terminal 29 or 33 only) Input for increment counting in the SLC counter.
- [61] Counter A (Terminal 29 or 33 only) Input for decrement counting in the SLC counter.
- [62] Reset Counter A Input for reset of counter A.
- [63] Counter B (Terminal 29 or 33 only) Input for increment counting in the SLC counter.
- [64] Counter B (Terminal 29 or 33 only) Input for decrement counting in the SLC counter.
- [65] Reset Counter B Input for reset of counter B.
- [70] Mech. Brake Feedback Brake feedback for hoisting applications: Set par. 1-01 *Motor Control Principle* to [3] *flux w/ motor feedback*; set par. 1-72 *Start Function* to [6] *Hoist mech brake Ref*.
- [71] Mech. Brake Feedback inv. Inverted brake feedback for hoisting applications

| | | |
|------|-------------------|---|
| [72] | PID error inverse | When enabled, it inverts the resulting error from the process PID controller. Available only if "Configuration Mode" is set to "Surface Winder", "Extended PID Speed OL" or "Extended PID Speed CL". |
| [73] | PID reset I-part | When enabled, resets the I-part of the Process PID controller. Equivalent to par. 7-40 <i>Process PID I-part Reset</i> . Available only if "Configuration Mode" is set to "Surface Winder", "Extended PID Speed OL" or "Extended PID Speed CL". |
| [74] | PID enable | When enabled, enables the extended process PID controller. Equivalent to par. 7-50 <i>Process PID Extended PID</i> . Available only if "Configuration Mode" is set "Extended PID Speed OL" or "Extended PID Speed CL". |
| [80] | PTC Card 1 | All Digital Inputs can be set to PTC Card 1 [80]. However, only one Digital Input must be set to this choice. |

5-20 Terminal X46/1 Digital Input

Option:

[0] * No operation

Function:

This parameter is active when option module MCB 113 is installed in the frequency converter. Functions are described under 5-1* *Digital Inputs*

5-21 Terminal X46/3 Digital Input

Option:

[0] * No operation

Function:

This parameter is active when option module MCB 113 is installed in the frequency converter. Functions are described under 5-1* *Digital Inputs*

5-22 Terminal X46/5 Digital Input

Option:

[0] * No operation

Function:

This parameter is active when option module MCB 113 is installed in the frequency converter. Functions are described under 5-1* *Digital Inputs*

5-23 Terminal X46/7 Digital Input

Option:

[0] * No operation

Function:

This parameter is active when option module MCB 113 is installed in the frequency converter. Functions are described under 5-1* *Digital Inputs*

5-24 Terminal X46/9 Digital Input

Option:

[0] * No operation

Function:

This parameter is active when option module MCB 113 is installed in the frequency converter. Functions are described under 5-1* *Digital Inputs*

5-25 Terminal X46/11 Digital Input

Option:

[0] * No operation

Function:

This parameter is active when option module MCB 113 is installed in the frequency converter. Functions are described under 5-1* *Digital Inputs*

5-26 Terminal X46/13 Digital Input

Option:

[0] * No operation

Function:

This parameter is active when option module MCB 113 is installed in the frequency converter. Functions are described under 5-1* *Digital Inputs*

5.2.2 5-3* Digital Outputs

Parameters for configuring the output functions for the output terminals. The 2 solid-state digital outputs are common for terminals 27 and 29. Set the I/O function for terminal 27 in par. 5-01 *Terminal 27 Mode*, and set the I/O function for terminal 29 in par. 5-02 *Terminal 29 Mode*. These parameters cannot be adjusted while the motor is running.

| | | |
|------|-----------------------------------|---|
| [0] | No operation | <i>Default for all digital outputs and relay outputs</i> |
| [1] | Control ready | The control card is ready. E.g.: Feedback from a drive where the control is supplied by an external 24 V (MCB 107) and the main power to drive is not detected. |
| [2] | Drive ready | The frequency converter is ready for operation and applies a supply signal on the control board. |
| [3] | Drive ready / remote control | The frequency converter is ready for operation and is in Auto On mode. |
| [4] | Enable / no warning | Ready for operation. No start or stop command is been given (start/disable). No warnings are active. |
| [5] | VLT running | Motor is running and shaft torque present. |
| [6] | Running / no warning | Output speed is higher than the speed set in par. 1-81 <i>Min Speed for Function at Stop [RPM]</i> . The motor is running and there are no warnings. |
| [7] | Run in range / no warning | Motor is running within the programmed current and speed ranges set in par. 4-50 <i>Warning Current Low</i> to par. 4-53 <i>Warning Speed High</i> . There are no warnings. |
| [8] | Run on reference / no warning | Motor runs at reference speed. No warnings. |
| [9] | Alarm | An alarm activates the output. There are no warnings. |
| [10] | Alarm or warning | An alarm or a warning activates the output. |
| [11] | At torque limit | The torque limit set in par. 4-16 <i>Torque Limit Motor Mode</i> or par. 4-17 <i>Torque Limit Generator Mode</i> has been exceeded. |
| [12] | Out of current range | The motor current is outside the range set in par. 4-18 <i>Current Limit</i> . |
| [13] | Below current, low | Motor current is lower than set in par. 4-50 <i>Warning Current Low</i> . |
| [14] | Above current, high | Motor current is higher than set in par. 4-51 <i>Warning Current High</i> . |
| [15] | Out of range | Output frequency is outside the frequency range set in par. 4-52 <i>Warning Speed Low</i> and par. 4-53 <i>Warning Speed High</i> . |
| [16] | Below speed, low | Output speed is lower than the setting in par. 4-52 <i>Warning Speed Low</i> . |
| [17] | Above speed, high | Output speed is higher than the setting in par. 4-53 <i>Warning Speed High</i> . |
| [18] | Out of feedback range | Feedback is outside the range set in par. 4-56 <i>Warning Feedback Low</i> and par. 4-57 <i>Warning Feedback High</i> . |
| [19] | Below feedback low | Feedback is below the limit set in par. 4-56 <i>Warning Feedback Low</i> . |
| [20] | Above feedback high | Feedback is above the limit set in par. 4-57 <i>Warning Feedback High</i> . |
| [21] | Thermal warning | The thermal warning turns on when the temperature exceeds the limit in the motor, the frequency converter, the brake resistor, or the thermistor. |
| [22] | Ready, no thermal warning | Frequency converter is ready for operation and there is no over-temperature warning. |
| [23] | Remote, ready, no thermal warning | Frequency converter is ready for operation and is in Auto On mode. There is no over-temperature warning. |
| [24] | Ready, no over-/ under voltage | Frequency converter is ready for operation and the mains voltage is within the specified voltage range (see <i>General Specifications</i> section in the Designn Guide). |
| [25] | Reverse | <i>Reversing. Logic '1' when CW rotation of the motor. Logic '0' when CCW rotation of the motor. If the motor is not rotating the output will follow the reference.</i> |
| [26] | Bus OK | Active communication (no time-out) via the serial communication port. |
| [27] | Torque limit and stop | Use in performing a coasting stop and in torque limit condition. If the frequency converter has received a stop signal and is at the torque limit, the signal is Logic '0'. |
| [28] | Brake, no brake warning | Brake is active and there are no warnings. |
| [29] | Brake ready, no fault | Brake is ready for operation and there are no faults. |
| [30] | Brake fault (IGBT) | Output is Logic '1' when the brake IGBT is short-circuited. Use this function to protect the frequency converter if there is a fault on the brake modules. Use the output/relay to cut out the main voltage from the frequency converter. |

| | | |
|------|-----------------------------------|--|
| [31] | Relay 123 | Relay is activated when Control Word [0] is selected in par. group 8-**. |
| [32] | Mechanical brake control | Enables control of an external mechanical brake, see description in the section <i>Control of Mechanical Brake</i> , and par. group 2-2* |
| [33] | Safe stop activated (FC 302 only) | Indicates that the safe stop on terminal 37 has been activated. |
| [40] | Out of ref range | Active when the actual speed is outside settings in par. 4-52 <i>Warning Speed Low</i> to par. 4-55 <i>Warning Reference High</i> . |
| [41] | Below reference low | Active when actual speed is below speed reference setting. |
| [42] | Above reference high | Active when actual speed is above speed reference setting |
| [43] | Extended PID Limit | |
| [45] | Bus Ctrl | Controls output via bus. The state of the output is set in par. 5-90 <i>Digital & Relay Bus Control</i> . The output state is retained in the event of bus time-out. |
| [46] | Bus Ctrl On at timeout | Controls output via bus. The state of the output is set in par. 5-90 <i>Digital & Relay Bus Control</i> . In the event of bus time-out the output state is set high (On). |
| [47] | Bus Ctrl Off at timeout | Controls output via bus. The state of the output is set in par. 5-90 <i>Digital & Relay Bus Control</i> . In the event of bus time-out the output state is set low (Off). |
| [51] | MCO controlled | Active when a MCO 302 or MCO 305 is connected. The output is controlled from option. |
| [55] | Pulse output | |
| [60] | Comparator 0 | See par. group 13-1*. If Comparator 0 is evaluated as TRUE, the output will go high. Otherwise, it will be low. |
| [61] | Comparator 1 | See par. group 13-1*. If Comparator 1 is evaluated as TRUE, the output will go high. Otherwise, it will be low. |
| [62] | Comparator 2 | See par. group 13-1*. If Comparator 2 is evaluated as TRUE, the output will go high. Otherwise, it will be low. |
| [63] | Comparator 3 | See par. group 13-1*. If Comparator 3 is evaluated as TRUE, the output will go high. Otherwise, it will be low. |
| [64] | Comparator 4 | See par. group 13-1*. If Comparator 4 is evaluated as TRUE, the output will go high. Otherwise, it will be low. |
| [65] | Comparator 5 | See par. group 13-1*. If Comparator 5 is evaluated as TRUE, the output will go high. Otherwise, it will be low. |
| [70] | Logic Rule 0 | See par. group 13-4*. If Logic Rule 0 is evaluated as TRUE, the output will go high. Otherwise, it will be low. |
| [71] | Logic Rule 1 | See par. group 13-4*. If Logic Rule 1 is evaluated as TRUE, the output will go high. Otherwise, it will be low. |
| [72] | Logic Rule 2 | See par. group 13-4*. If Logic Rule 2 is evaluated as TRUE, the output will go high. Otherwise, it will be low. |
| [73] | Logic Rule 3 | See par. group 13-4*. If Logic Rule 3 is evaluated as TRUE, the output will go high. Otherwise, it will be low. |
| [74] | Logic Rule 4 | See par. group 13-4*. If Logic Rule 4 is evaluated as TRUE, the output will go high. Otherwise, it will be low. |
| [75] | Logic Rule 5 | See par. group 13-4*. If Logic Rule 5 is evaluated as TRUE, the output will go high. Otherwise, it will be low. |
| [80] | SL Digital Output A | See par. 13-52 <i>SL Controller Action</i> . The output will go high whenever the Smart Logic Action [38] <i>Set dig. out. A high</i> is executed. The output will go low whenever the Smart Logic Action [32] <i>Set dig. out. A low</i> is executed. |
| [81] | SL Digital Output B | See par. 13-52 <i>SL Controller Action</i> . The input will go high whenever the Smart Logic Action [39] <i>Set dig. out. A high</i> is executed. The input will go low whenever the Smart Logic Action [33] <i>Set dig. out. A low</i> is executed. |
| [82] | SL Digital Output C | See par. 13-52 <i>SL Controller Action</i> . The input will go high whenever the Smart Logic Action [40] <i>Set dig. out. A high</i> is executed. The input will go low whenever the Smart Logic Action [34] <i>Set dig. out. A low</i> is executed. |

| | | |
|-------|------------------------|--|
| [83] | SL Digital Output D | See par. 13-52 <i>SL Controller Action</i> . The input will go high whenever the Smart Logic Action [41] <i>Set dig. out. A high</i> is executed. The input will go low whenever the Smart Logic Action [35] <i>Set dig. out. A low</i> is executed. |
| [84] | SL Digital Output E | See par. 13-52 <i>SL Controller Action</i> . The input will go high whenever the Smart Logic Action [42] <i>Set dig. out. A high</i> is executed. The input will go low whenever the Smart Logic Action [36] <i>Set dig. out. A low</i> is executed. |
| [85] | SL Digital Output F | See par. 13-52 <i>SL Controller Action</i> . The input will go high whenever the Smart Logic Action [43] <i>Set dig. out. A high</i> is executed. The input will go low whenever the Smart Logic Action [37] <i>Set dig. out. A low</i> is executed. |
| [120] | Local reference active | Output is high when par. 3-13 <i>Reference Site</i> = [2] Local or when par. 3-13 <i>Reference Site</i> = [0] <i>Linked to hand auto</i> at the same time as the LCP is in Hand on mode. |

| Reference site set in par. 3-13 <i>Reference Site</i> | Local reference active [120] | Remote reference active [121] |
|--|------------------------------|-------------------------------|
| Reference site: Local par. 3-13 <i>Reference Site</i> [2] | 1 | 0 |
| Reference site: Remote par. 3-13 <i>Reference Site</i> [1] | 0 | 1 |
| Reference site: Linked to Hand/ Auto | | |
| Hand | 1 | 0 |
| Hand -> off | 1 | 0 |
| Auto -> off | 0 | 0 |
| Auto | 0 | 1 |

| | | |
|-------|-------------------------|---|
| [121] | Remote reference active | Output is high when par. 3-13 <i>Reference Site</i> = <i>Remote</i> [1] or <i>Linked to hand/auto</i> [0] while the LCP is in [Auto on] mode. See above. |
| [122] | No alarm | Output is high when no alarm is present. |
| [123] | Start command active | Output is high when there is an active Start command (i.e. via digital input bus connection or [Hand on] or [Auto on]), and no Stop or Start command is active. |
| [124] | Running reverse | Output is high when the frequency converter is running counter clockwise (the logical product of the status bits 'running' AND 'reverse'). |
| [125] | Drive in hand mode | Output is high when the frequency converter is in Hand on mode (as indicated by the LED light above [Hand on]). |
| [126] | Drive in auto mode | Output is high when the frequency converter is in Hand on mode (as indicated by the LED light above [Auto on]). |

5-40 Function Relay

Array [9]

(Relay 1 [0], Relay 2 [1], Relay 3 [2] (MCB 113), Relay 4 [3] (MCB 113), Relay 5 [4] (MCB 113), Relay 6 [5] (MCB 113), Relay 7 [6] (MCB 105), Relay 8 [7] (MCB 105), Relay 9 [8] (MCB 105))

Option:

Function:

| | | |
|-------|----------------------|--|
| [0] * | No operation | All digital and relay outputs are default set to "No Operation". |
| [1] | Control ready | The control card is ready. E.g.: Feedback from a drive where the control is supplied by an external 24 V (MCB 107) and the main power to drive is not detected. |
| [2] | Drive ready | Drive is ready to operate. Mains and control supplies are OK. |
| [3] | Drive rdy/rem ctrl | The frequency converter is ready for operation and is in Auto On mode |
| [4] | Enable / no warning | Ready for operation. No start or stop commands have been applied (start/disable). No warnings are active. |
| [5] | Running | Motor is running, and shaft torque present. |
| [6] | Running / no warning | Output speed is higher than the speed set in par. 1-81 <i>Min Speed for Function at Stop [RPM]</i> Min Speed for Function at Stop [RPM]. The motor is running and no warnings. |

| | | |
|------|-----------------------|---|
| [7] | Run in range/no warn | Motor is running within the programmed current and speed ranges set in par. 4-50 <i>Warning Current Low</i> and par. 4-53 <i>Warning Speed High</i> . No warnings. |
| [8] | Run on ref/no warn | Motor runs at reference speed. No warnings. |
| [9] | Alarm | An alarm activates the output. No warnings |
| [10] | Alarm or warning | An alarm or a warning activates the output. |
| [11] | At torque limit | The torque limit set in par. 4-16 <i>Torque Limit Motor Mode</i> or par. 4-17 <i>Torque Limit Generator Mode</i> has been exceeded. |
| [12] | Out of current range | The motor current is outside the range set in par. 4-18 <i>Current Limit</i> . |
| [13] | Below current, low | Motor current is lower than set in par. 4-50 <i>Warning Current Low</i> . |
| [14] | Above current, high | Motor current is higher than set in par. 4-51 <i>Warning Current High</i> . |
| [15] | Out of speed range | Output speed/frequency is outside the frequency range set in par. 4-52 <i>Warning Speed Low</i> and par. 4-53 <i>Warning Speed High</i> . |
| [16] | Below speed, low | Output speed is lower than the setting in par. 4-52 <i>Warning Speed Low</i> |
| [17] | Above speed, high | Output speed is higher than the setting in par. 4-53 <i>Warning Speed High</i> . |
| [18] | Out of feedb. range | Feedback is outside the range set in par. 4-56 <i>Warning Feedback Low</i> and par. 4-57 <i>Warning Feedback High</i> . |
| [19] | Below feedback, low | Feedback is below the limit set in par. 4-56 <i>Warning Feedback Low</i> . |
| [20] | Above feedback, high | Feedback is above the limit set in par. 4-57 <i>Warning Feedback High</i> . |
| [21] | Thermal warning | Thermal warning turns on when the temperature exceeds the limit either in motor, frequency converter, brake resistor, or connected thermistor. |
| [22] | Ready,no thermal W | Frequency converter is ready for operation and there is no over-temperature warning. |
| [23] | Remote,ready,no TW | Frequency converter is ready for operation and is in Auto On mode. There is no over-temperature warning. |
| [24] | Ready, Voltage OK | Frequency converter is ready for operation and the mains voltage is within the specified voltage range (see General Specifications section in Design Guide). |
| [25] | Reverse | Logic '1' when CW rotation of the motor. Logic '0' when CCW rotation of the motor. If the motor is not rotating the output will follow the reference. |
| [26] | Bus OK | Active communication (no time-out) via the serial communication port. |
| [27] | Torque limit & stop | Use in performing a coasted stop and frequency converter in torque limit condition. If the frequency converter has received a stop signal and is in torque limit, the signal is Logic '0'. |
| [28] | Brake, no brake war | Brake is active and there are no warnings. |
| [29] | Brake ready, no fault | Brake is ready for operation and there are no faults. |
| [30] | Brake fault (IGBT) | Output is Logic '1' when the brake IGBT is short-circuited. Use this function to protect the frequency converter if there is a fault on the brake module. Use the digital output/relay to cut out the main voltage from the frequency converter. |
| [31] | Relay 123 | Digital output/relay is activated when Control Word [0] is selected in par. group 8-**. |
| [32] | Mech brake ctrl | Selection of mechanical brake control. When selected parameters in par. group 2-2* are active. The output must be reinforced to carry the current for the coil in the brake. Usually solved by connecting an external relay to the selected digital output. |
| [33] | Safe stop active | (FC 302 only) Indicates that the safe stop on terminal 37 has been activated. |
| [36] | Control word bit 11 | Activate relay 1 by control word from fieldbus. No other functional impact in the frequency converter. Typical application: controlling auxiliary device from fieldbus. The function is valid when FC profile [0] in par par. 8-10 <i>Control Word Profile</i> is selected. |

| | | |
|------|------------------------|--|
| [37] | Control word bit 12 | Activate relay 2 FC 302 only) by control word from fieldbus. No other functional impact in the frequency converter. Typical application: controlling auxiliary device from fieldbus. The function is valid when FC profile [0] in par. 8-10 <i>Control Word Profile</i> is selected. |
| [38] | Motor feedback error | Failure in the speed feedback loop from motor running in closed loop. The output can eventually be used to prepare switching the drive in open loop in emergency case. |
| [39] | Tracking error | When the difference between calculated speed and actual speed in par. 4-35 <i>Tracking Error</i> is larger than selected the digital output/relay is active. |
| [40] | Out of ref range | Active when the actual speed is outside settings in par. 4-52 <i>Warning Speed Low</i> to par. 4-55 <i>Warning Reference High</i> . |
| [41] | Below reference, low | Active when actual speed is below speed reference setting. |
| [42] | Above ref, high | Active when actual speed is above speed reference setting. |
| [43] | Extended PID Limit | |
| [45] | Bus ctrl. | Controls digital output/relay via bus. The state of the output is set in par. 5-90 <i>Digital & Relay Bus Control</i> . The output state is retained in the event of bus time-out. |
| [46] | Bus ctrl, 1 if timeout | Controls output via bus. The state of the output is set in par. 5-90 <i>Digital & Relay Bus Control</i> . In the event of bus time-out the output state is set high (On). |
| [47] | Bus ctrl, 0 if timeout | Controls output via bus. The state of the output is set in par. 5-90 <i>Digital & Relay Bus Control</i> . In the event of bus time-out the output state is set low (Off). |
| [51] | MCO controlled | Active when a MCO 302 or MCO 305 is connected. The output is controlled from option. |
| [60] | Comparator 0 | See par. group 13-1* (Smart Logic Control). If Comparator 0 in SLC is TRUE, the output will go high. Otherwise, it will be low. |
| [61] | Comparator 1 | See par. group 13-1* (Smart Logic Control). If Comparator 1 in SLC is TRUE, the output will go high. Otherwise, it will be low. |
| [62] | Comparator 2 | See par. group 13-1* (Smart Logic Control). If Comparator 2 in SLC is TRUE, the output will go high. Otherwise, it will be low. |
| [63] | Comparator 3 | See par. group 13-1* (Smart Logic Control). If Comparator 3 in SLC is TRUE, the output will go high. Otherwise, it will be low. |
| [64] | Comparator 4 | See par. group 13-1* (Smart Logic Control). If Comparator 4 in SLC is TRUE, the output will go high. Otherwise, it will be low. |
| [65] | Comparator 5 | See par. group 13-1* (Smart Logic Control). If Comparator 5 in SLC is TRUE, the output will go high. Otherwise, it will be low. |
| [70] | Logic rule 0 | See par. group 13-4*(Smart Logic Control). If Logic Rule 0 in SLC is TRUE, the output will go high. Otherwise, it will be low. |
| [71] | Logic rule 1 | See par. group 13-4*(Smart Logic Control). If Logic Rule 1 in SLC is TRUE, the output will go high. Otherwise, it will be low. |
| [72] | Logic rule 2 | See par. group 13-4*(Smart Logic Control). If Logic Rule 2 in SLC is TRUE, the output will go high. Otherwise, it will be low. |
| [73] | Logic rule 3 | See par. group 13-4*(Smart Logic Control). If Logic Rule 3 in SLC is TRUE, the output will go high. Otherwise, it will be low. |
| [74] | Logic rule 4 | See par. group 13-4*(Smart Logic Control). If Logic Rule 4 in SLC is TRUE, the output will go high. Otherwise, it will be low. |
| [75] | Logic rule 5 | See par. group 13-4*(Smart Logic Control). If Logic Rule 5 in SLC is TRUE, the output will go high. Otherwise, it will be low. |
| [80] | SL digital output A | See par. 13-52 <i>SL Controller Action</i> . Output A is low on Smart Logic Action [32]. Output A is high on Smart Logic Action [38]. |

| [81] | SL digital output B | See par. 13-52 <i>SL Controller Action</i> . Output B is low on Smart Logic Action [33]. Output B is high on Smart Logic Action [39]. | | | | | | | | | | | | | | | | | | | | | | | | |
|--|------------------------------|---|---|------------------------------|-------------------------------|---|---|---|--|---|---|--------------------------------------|--|--|------|---|---|-------------|---|---|-------------|---|---|------|---|---|
| [82] | SL digital output C | See par. 13-52 <i>SL Controller Action</i> . Output C is low on Smart Logic Action [34]. Output C is high on Smart Logic Action [40]. | | | | | | | | | | | | | | | | | | | | | | | | |
| [83] | SL digital output D | See par. 13-52 <i>SL Controller Action</i> . Output D is low on Smart Logic Action [35]. Output D is high on Smart Logic Action [41]. | | | | | | | | | | | | | | | | | | | | | | | | |
| [84] | SL digital output E | See par. 13-52 <i>SL Controller Action</i> . Output E is low on Smart Logic Action [36]. Output E is high on Smart Logic Action [42]. | | | | | | | | | | | | | | | | | | | | | | | | |
| [85] | SL digital output F | See par. 13-52 <i>SL Controller Action</i> . Output F is low on Smart Logic Action [37]. Output F is high on Smart Logic Action [43]. | | | | | | | | | | | | | | | | | | | | | | | | |
| [120] | Local ref active | Output is high when par. 3-13 <i>Reference Site</i> = [2] Local or when par. 3-13 <i>Reference Site</i> = [0] Linked to hand auto at the same time as the LCP is in Hand on mode. | | | | | | | | | | | | | | | | | | | | | | | | |
| <table border="1"> <thead> <tr> <th>Reference site set in par. 3-13 <i>Reference Site</i></th> <th>Local reference active [120]</th> <th>Remote reference active [121]</th> </tr> </thead> <tbody> <tr> <td>Reference site: Local par. 3-13 <i>Reference Site</i> [2]</td> <td>1</td> <td>0</td> </tr> <tr> <td>Reference site: Remote par. 3-13 <i>Reference Site</i> [1]</td> <td>0</td> <td>1</td> </tr> <tr> <td>Reference site: Linked to Hand/ Auto</td> <td></td> <td></td> </tr> <tr> <td>Hand</td> <td>1</td> <td>0</td> </tr> <tr> <td>Hand -> off</td> <td>1</td> <td>0</td> </tr> <tr> <td>Auto -> off</td> <td>0</td> <td>0</td> </tr> <tr> <td>Auto</td> <td>0</td> <td>1</td> </tr> </tbody> </table> | | | Reference site set in par. 3-13 <i>Reference Site</i> | Local reference active [120] | Remote reference active [121] | Reference site: Local par. 3-13 <i>Reference Site</i> [2] | 1 | 0 | Reference site: Remote par. 3-13 <i>Reference Site</i> [1] | 0 | 1 | Reference site: Linked to Hand/ Auto | | | Hand | 1 | 0 | Hand -> off | 1 | 0 | Auto -> off | 0 | 0 | Auto | 0 | 1 |
| Reference site set in par. 3-13 <i>Reference Site</i> | Local reference active [120] | Remote reference active [121] | | | | | | | | | | | | | | | | | | | | | | | | |
| Reference site: Local par. 3-13 <i>Reference Site</i> [2] | 1 | 0 | | | | | | | | | | | | | | | | | | | | | | | | |
| Reference site: Remote par. 3-13 <i>Reference Site</i> [1] | 0 | 1 | | | | | | | | | | | | | | | | | | | | | | | | |
| Reference site: Linked to Hand/ Auto | | | | | | | | | | | | | | | | | | | | | | | | | | |
| Hand | 1 | 0 | | | | | | | | | | | | | | | | | | | | | | | | |
| Hand -> off | 1 | 0 | | | | | | | | | | | | | | | | | | | | | | | | |
| Auto -> off | 0 | 0 | | | | | | | | | | | | | | | | | | | | | | | | |
| Auto | 0 | 1 | | | | | | | | | | | | | | | | | | | | | | | | |
| [121] | Remote ref active | Output is high when par. 3-13 <i>Reference Site</i> = Remote [1] or Linked to hand/auto [0] while the LCP is in [Auto on] mode. See above. | | | | | | | | | | | | | | | | | | | | | | | | |
| [122] | No alarm | Output is high when no alarm is present. | | | | | | | | | | | | | | | | | | | | | | | | |
| [123] | Start command activ | Output is high when the Start command high (i.e. via digital input, bus connection or [Hand on] or [Auto on]), and a Stop has been last command. | | | | | | | | | | | | | | | | | | | | | | | | |
| [124] | Running reverse | Output is high when the frequency converter is running counter clockwise (the logical product of the status bits 'running' AND 'reverse'). | | | | | | | | | | | | | | | | | | | | | | | | |
| [125] | Drive in hand mode | Output is high when the frequency converter is in Hand on mode (as indicated by the LED light above [Hand on]). | | | | | | | | | | | | | | | | | | | | | | | | |
| [126] | Drive in auto mode | Output is high when the frequency converter is in 'Auto' mode (as indicated by LED on above [Auto On]). | | | | | | | | | | | | | | | | | | | | | | | | |

5

5-41 On Delay, Relay

Enter the delay of the relay cut-in time. See par. 5-40 *Function Relay*.

Array [9] (Relay 1 [0], Relay 2 [1], Relay 3 [2], Relay 4 [3], Relay 5 [4], Relay 6 [5], Relay 6 [5], Relay 7 [6], Relay 8 [7], Relay 9 [8])

0.01s* [0.01 - 600.00 s]

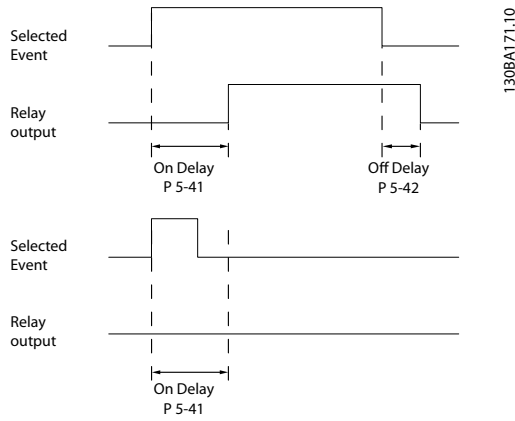

5

5-42 Off Delay, Relay

Enter the delay of the relay cut-out time. See par. 5-40 *Function Relay*.

Array [8] (Relay 1 [0], Relay 2 [1], Relay 3 [2], Relay 4 [3], Relay 5 [4], Relay 6 [5], Relay 6 [5], Relay 7 [6], Relay 8 [7], Relay 9 [8])

0.01s* [0.01 - 600.00 s.]

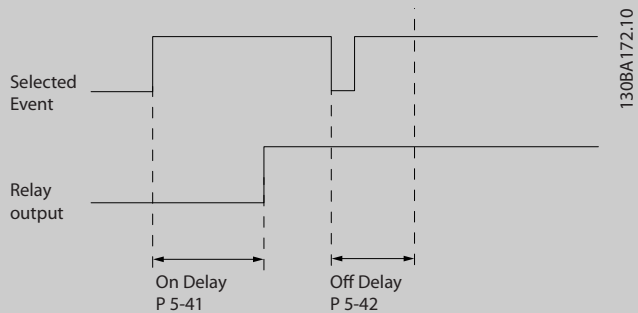

If the Selected Event condition changes before the on- or off delay timer expires, the relay output is unaffected.

5.3 6-** Analog Outputs

5.3.1 6-7* Analog Output 3 MCB 113

Parameters for configuring the scaling and limits for analog output 3, Terminal X45/1 and X45/2. Analog outputs are current outputs: 0/4 – 20 mA. Resolution on analog output is 11 bit.

| 6-70 Terminal X45/1 Output | | |
|----------------------------|--|---|
| Option: | | Function: |
| | | Select the function of Terminal X45/1 as an analog current output. |
| [0] | No operation | When no signal on the analog output. |
| [52] | MCO 305 0-20 mA | |
| [53] | MCO 305 4-20 mA | |
| [100] | Output frequency 0-20 mA | 0 Hz = 0 mA; 100 Hz = 20 mA. |
| [101] | Reference 0-20 mA | Par. 3-00 [Min - Max] 0% = 0 mA; 100% = 20 mA Par. 3-00 [-Max - Max] -100% = 0 mA; 0% = 10 mA; +100% = 20 mA |
| [102] | Feedback | |
| [103] | Motor current 0-20 mA | Value is taken from par. 16-37 <i>Inv. Max. Current</i> . Inverter max. current (160% current) is equal to 20 mA. Example: Inverter norm current (11 kW) = 24 A. 160 % = 38.4 A. Motor norm current = 22 A Read-out 11.46 mA. $\frac{20 \text{ mA} \times 22 \text{ A}}{38.4 \text{ A}} = 11.46 \text{ mA}$ In case the norm motor current is equal to 20 mA, the output setting of par. 6-52 <i>Terminal 42 Output Max Scale</i> is: $\frac{I_{VLT_{Max}} \times 100}{I_{Motor_{Norm}}} = \frac{38.4 \times 100}{22} = 175 \%$ |
| [104] | Torque rel to lim 0-20 mA | The torque setting is related to setting in par. 4-16 <i>Torque Limit Motor Mode</i> |
| [105] | Torque rel to rated motor torque 0-20 mA | The torque is related to the motor torque setting. |
| [106] | Power 0-20 mA | Taken from par. 1-20 <i>Motor Power [kW]</i> . |
| [107] | Speed 0-20 mA | Taken from par. 3-03 <i>Maximum Reference</i> . 20 mA = value in par. 3-03 <i>Maximum Reference</i> |
| [108] | Torque ref. 0-20 mA | Torque reference related to 160% torque. |
| [109] | Max Out Freq 0-20 mA | In relation to par. 4-19 <i>Max Output Frequency</i> . |
| [130] | Output freq. 4-20 mA | 0 Hz = 4 mA, 100 Hz = 20 mA |
| [131] | Reference 4-20 mA | Par. 3-00 [Min-Max] 0% = 4 mA; 100% = 20 mA Par. 3-00 [-Max-Max] -100% = 4mA; 0% = 12 mA; +100% = 20 mA |
| [132] | Feedback 4-20 mA | |
| [133] | Motor cur. 4-20 mA | Value is taken from par. 16-37 <i>Inv. Max. Current</i> . Inverter max. current (160% current) is equal to 20 mA. Example: Inverter norm current (11 kW) = 24 A. 160 % = 38.4 A. Motor norm current = 22 A Read-out 11.46 mA. $\frac{16 \text{ mA} \times 22 \text{ A}}{38.4 \text{ A}} = 9.17 \text{ mA}$ In case the norm motor current is equal to 20 mA, the output setting of par. 6-52 <i>Terminal 42 Output Max Scale</i> is: $\frac{I_{VLT_{Max}} \times 100}{I_{Motor_{Norm}}} = \frac{38.4 \times 100}{22} = 175 \%$ |
| [134] | Torque % lim. 4-20 mA | The torque setting is related to setting in par. 4-16 <i>Torque Limit Motor Mode</i> . |
| [135] | Torque % nom 4-20 mA | The torque setting is related to the motor torque setting. |
| [136] | Power 4-20 mA | Taken from par. 1-20 <i>Motor Power [kW]</i> |

| | | |
|-------|----------------------------|--|
| [137] | Speed 4-20 mA | Taken from par. 3-03 <i>Maximum Reference</i> . 20 mA = Value in par. 3-03 <i>Maximum Reference</i> . |
| [138] | Torque 4-20 mA | Torque reference related to 160% torque. |
| [139] | Bus ctrl. 0-20 mA | An output value set from fieldbus process data. The output will work independently of internal functions in the frequency converter. |
| [140] | Bus ctrl. 4-20 mA | An output value set from fieldbus process data. The output will work independently of internal functions in the frequency converter. |
| [141] | Bus ctrl. 0-20 mA, timeout | Par. 4-54 <i>Warning Reference Low</i> defines the behaviour of the analog output in case of bus timeout. |
| [142] | Bus ctrl. 4-20 mA, timeout | Par. 4-54 <i>Warning Reference Low</i> defines the behaviour of the analog output in case of bus timeout. |
| [150] | Max Out Freq 4-20 mA | In relation to par. 4-19 <i>Max Output Frequency</i> . |

5

6-71 Terminal X45/1 Output Min Scale

Range: 0.00%* [0.00 - 200.00%]
Function: Scale the minimum output of the selected analog signal at terminal X45/1, as a percentage of the maximum signal value. E.g. if 0 mA (or 0 Hz) is desired at 25% of the maximum output value, then programme 25%. Scaling values up to 100% can never be higher than the corresponding setting in par. 6-72 *Terminal X45/1 Max. Scale*.

6-72 Terminal X45/1 Output Max Scale

Range: 100%* [0.00 - 200.00%]
Function: Scale the maximum output of the selected analog signal at terminal X45/1. Set the value to the maximum value of the current signal output. Scale the output to give a current lower than 20 mA at full scale; or 20 mA at an output below 100% of the maximum signal value. If 20 mA is the desired output current at a value between 0 - 100% of the full-scale output, programme the percentage value in the parameter, i.e. 50% = 20 mA. If a current between 4 and 20 mA is desired at maximum output (100%), calculate the percentage value as follows (example where desired max. output is 10 mA):

$$\frac{I_{RANGE} [mA]}{I_{DESIRED MAX} [mA]} \times 100 \% = \frac{20 - 4 mA}{10 mA} \times 100 \% = 160 \%$$

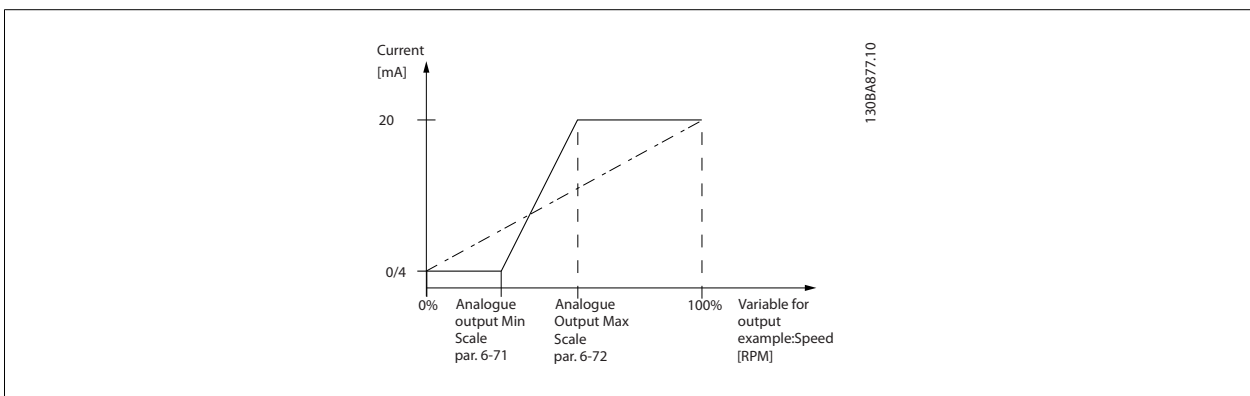

6-73 Terminal X45/1 Output Bus Control

Range: 0.00%* [0.00 - 100.00%]
Function: Holds the level of Analog Output 3 (terminal X45/1) if controlled by bus.

6-74 Terminal X45/1 Output Timeout Preset

Range: 0.00%* [0.00 - 100.00%]
Function: Holds the preset level of Analog Output 3 (terminal X45/1). In case of a bus timeout and a timeout function is selected in par. 6-70 *Terminal X45/1 Output* the output will preset to this level.

5.3.2 6-8* Analog Output 4 MCB 113

Parameters for configuring the scaling and limits for analog output 4. Terminal X45/3 and X45/4. Analog outputs are current outputs: 0/4 – 20 mA. Resolution on analog output is 11 bit.

6-80 Terminal X45/3 Output

| Option: | Function: |
|--------------------|--|
| [0] * No operation | Select the function of Terminal X45/3 as an analog current output. Same selections available as for par. 6-70 Terminal X45/1 Output |

6-81 Terminal X45/3 Output Min Scale

| Option: | Function: |
|--------------------------|--|
| [0.00%] * 0.00 - 200.00% | Scales the minimum output of the selected analog signal on terminal X45/3. Scale the minimum value as a percentage of the maximum signal value, i.e. 0 mA (or 0 Hz) is desired at 25% of the maximum output value and 25% is programmed. The value can never be higher than the corresponding setting in par. 6-82 Terminal X45/3 Max. Scale if value is below 100%. This parameter is active when option module MCB 113 is mounted in the frequency converter. |

6-82 Terminal X45/3 Output Max Scale

| Option: | Function: |
|--------------------------|---|
| [0.00%] * 0.00 - 200.00% | Scales the maximum output of the selected analog signal on terminal X45/3. Scale the value to the desired maximum value of the current signal output. Scale the output to give a lower current than 20 mA at full scale or 20 mA at an output below 100% of the maximum signal value. If 20 mA is the desired output current at a value between 0 - 100% of the full-scale output, program the percentage value in the parameter, i.e. 50% = 20 mA. If a current between 4 and 20 mA is desired at maximum output (100%), calculate the percentage value as follows (example where desired max. output is 10 mA): |

$$\frac{I_{RANGE} [mA]}{I_{DESIRED MAX} [mA]} \times 100\% = \frac{20 - 4 mA}{10 mA} \times 100\% = 160\%$$

6-83 Terminal X45/3 Output Bus Control

| Option: | Function: |
|--------------------------|---|
| [0.00%] * 0.00 - 100.00% | Holds the level of output 4 (X45/3) if controlled by bus. |

6-84 Terminal X45/3 Output Timeout Preset

| Option: | Function: |
|--------------------------|---|
| [0.00%] * 0.00 - 100.00% | Holds the present level of output 4 (X45/3). In case of a bus timeout and a timeout function is selected in par. 6-80 Terminal X45/3 Output the output will preset to this level. |

5.4 14-*** 24 V DC External Supply

5.4.1 14-8* Options

14-80 Option Supplied by External 24VDC

| Option: | Function: |
|-----------|---|
| [0] No | Select No [0] to use the drive's 24 V DC supply. |
| [1] * Yes | Select Yes [1] if an external 24 V DC supply will be used to power the option. Inputs/Outputs will be galvanically isolated from the drive when operated from an external supply. |

NB!
This parameter is only changing function by performing a power cycle.

5.5 16-** Data readouts

5.5.1 16-6* Inputs and Outputs

Parameters for reporting the digital and analog I/O ports.

16-60 Digital Input

Range:

0 [0 - 63]

Function:

View the signal states from the active digital inputs. Example: Input 18 corresponds to bit no. 5, '0' = no signal, '1' = connected signal. Bit 6 works in the opposite way, on = '0', off = '1' (safe stop input).

| | |
|-----------|----------------------------------|
| Bit 0 | Digital input term. 33 |
| Bit 1 | Digital input term. 32 |
| Bit 2 | Digital input term. 29 |
| Bit 3 | Digital input term. 27 |
| Bit 4 | Digital input term. 19 |
| Bit 5 | Digital input term. 18 |
| Bit 6 | Digital input term. 37 |
| Bit 7 | Digital input GP I/O term. X30/4 |
| Bit 8 | Digital input GP I/O term. X30/3 |
| Bit 9 | Digital input GP I/O term. X30/2 |
| Bit 10-63 | Reserved for future terminals |

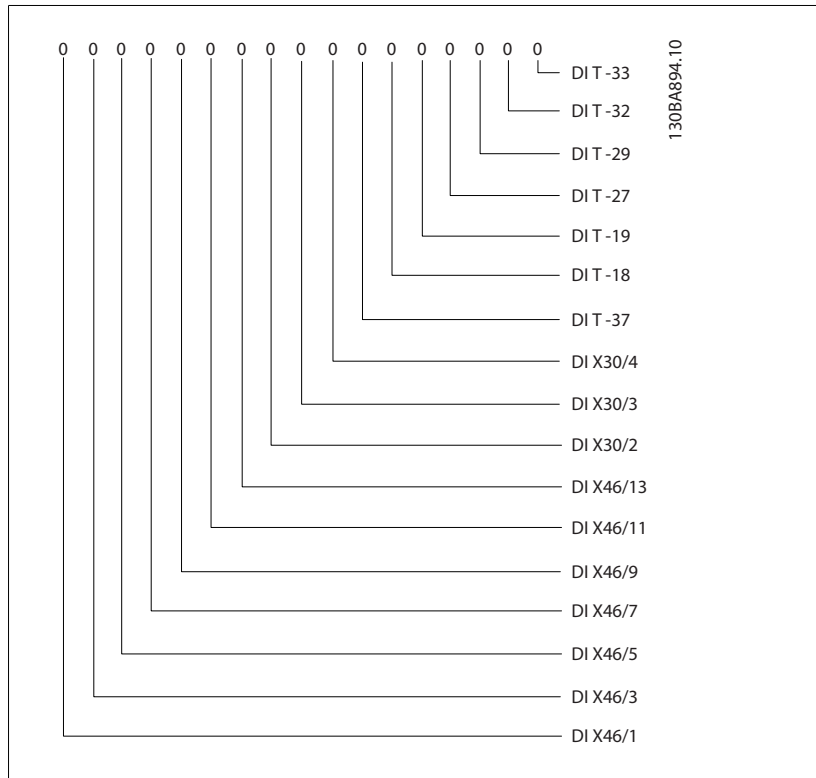

5

16-71 Relay Output [bin]

View the settings of all relays.

0.000 N/A* [0 - 511 N/A]

| | |
|----------|----------------------------|
| Bit 0 | Relay 9 |
| Bit 1 | Relay 8 |
| Bit 2 | Relay 7 |
| Bit 3 | Relay 2 |
| Bit 4 | Relay 1 |
| Bit 5 | Relay 6 |
| Bit 6 | Relay 5 |
| Bit 7 | Relay 4 |
| Bit 8 | Relay 3 |
| Bit 9-15 | Reserved for future relays |

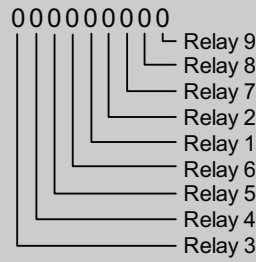

130BA689.10

5

16-78 Analog Out X45/1 [mA]

Range:

0.000* [0.000 - 30.000]

Function:

View the actual value at output X45/1. The value shown reflects the selection in par. 6-70 *Terminal X45/1 Output*.

16-79 Analog Out X45/3 [mA]

Range:

0.000* [0.000 - 30.000]

Function:

View the actual value at output X45/3. The value shown reflects the selection in par. 6-80 *Terminal X45/3 Output*.



www.danfoss.com/drives

Danfoss can accept no responsibility for possible errors in catalogues, brochures and other printed material. Danfoss reserves the right to alter its products without notice. This also applies to products already on order provided that such alterations can be made without subsequential changes being necessary in specifications already agreed. All trademarks in this material are property of the respective companies. Danfoss and the Danfoss logotype are trademarks of Danfoss A/S. All rights reserved.

