

VACON® NX Door Keypad Mounting Kit

1 Mounting Instructions

1.1 Introduction

The Door Keypad Mounting Kit is used for standard control keypad purposes and it is installed on the door of a switchgear cabinet. For the installation of VACON® NX Door Keypad Mounting Kit, you need the parts as shown in [Illustration 1](#) and tools to make the opening for the keypad and holes for the screws in the cabinet door.

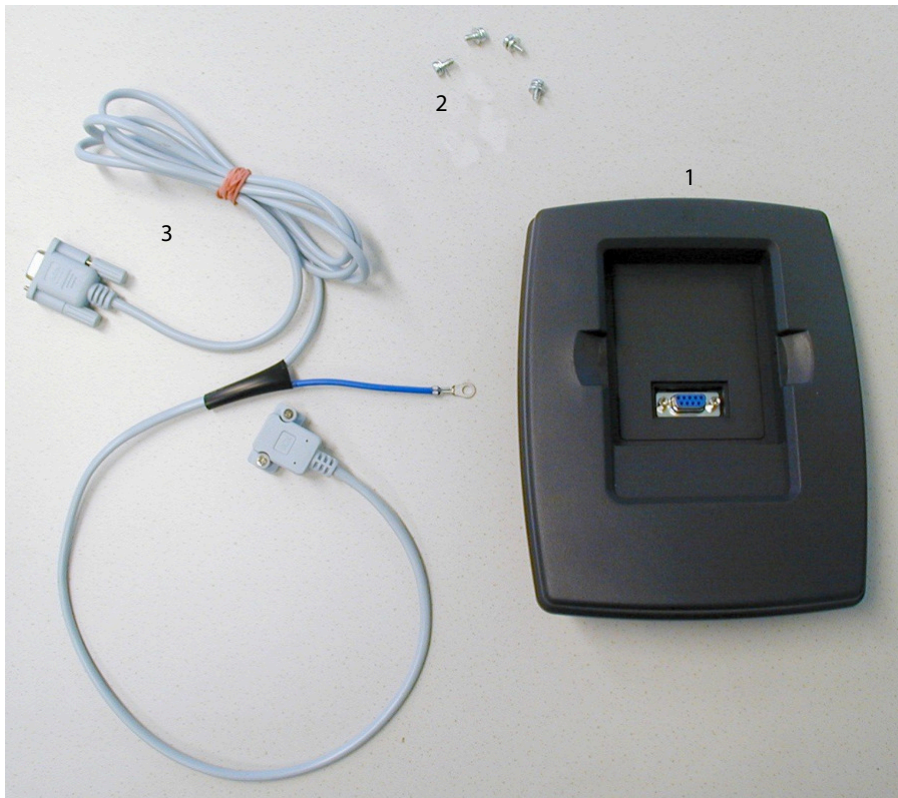

Illustration 1: Parts of VACON® NX Door Keypad Mounting Kit

1	Door Keypad Mounting Kit	3	Connection Cable (VACON)
2	4 screws (M4x8-DIN6900-3-Combi-Delta-TX 8.8), attached to the Door Keypad Mounting Kit		

NOTE! Make sure that you have received all the necessary parts.

1.2 Mounting Procedure

Follow the instructions to install Door Keypad Mounting Kit for VACON® NX AC Drives.

Procedure

1. Make an opening in the cabinet door for the control keypad using the keypad dimensions (real scale) in [Illustration 5](#). The dimensions of the opening must be 144 (±3) mm *115(±3) mm.
2. Make the holes for the screws (M4*4) using the real scale dimensions of [Illustration 5](#).
3. Place the control keypad in the opening so that the screw holes made in the cabinet door meet the bushings on the back-side of the control keypad.
4. Fix the control keypad on the cabinet door by tightening the screws. The tightening torque is 1.5 Nm.
5. Connect the VACON cable to the terminal of the control keypad. See [Illustration 2](#) and [Illustration 3](#) below.

6. Attach the grounding cable. See [Illustration 2](#) and [Illustration 3](#) below.
7. In FR8, make a sufficiently wide opening for the grounding cable by cutting the grid of the cable cover as wide as necessary. Attach the cable cover. See [Illustration 4](#) below.
8. VACON® NX Door Keypad Mounting Kit is now ready to use.

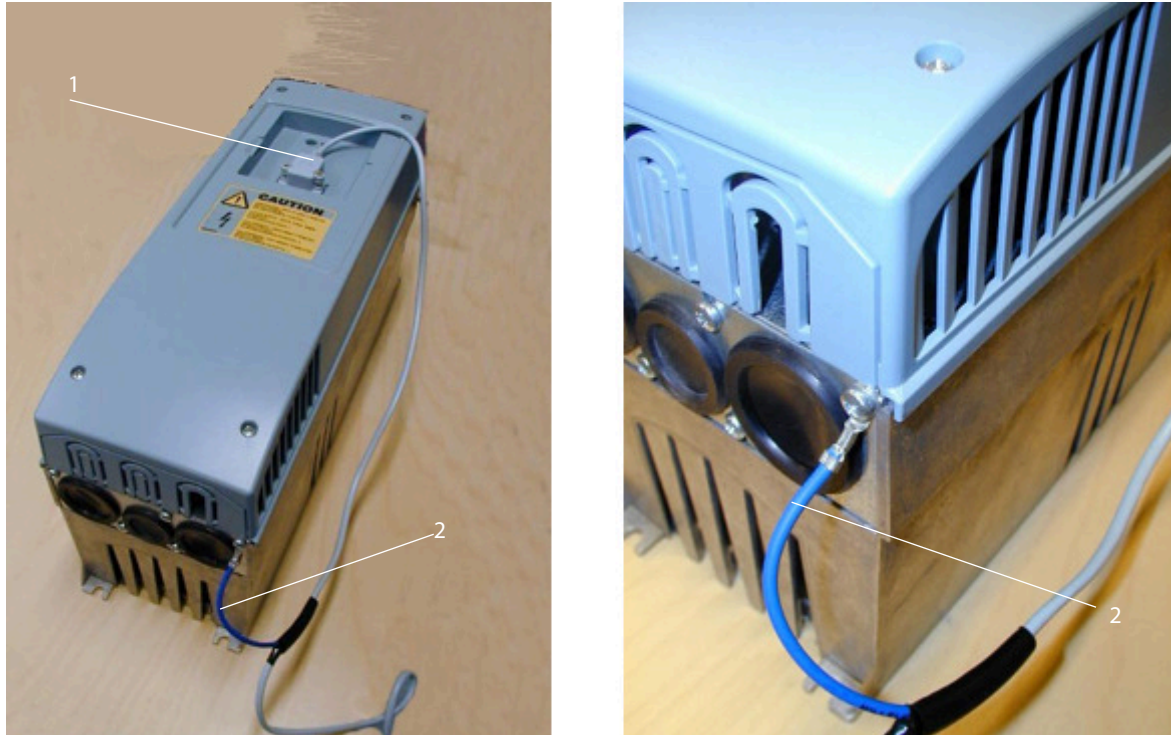
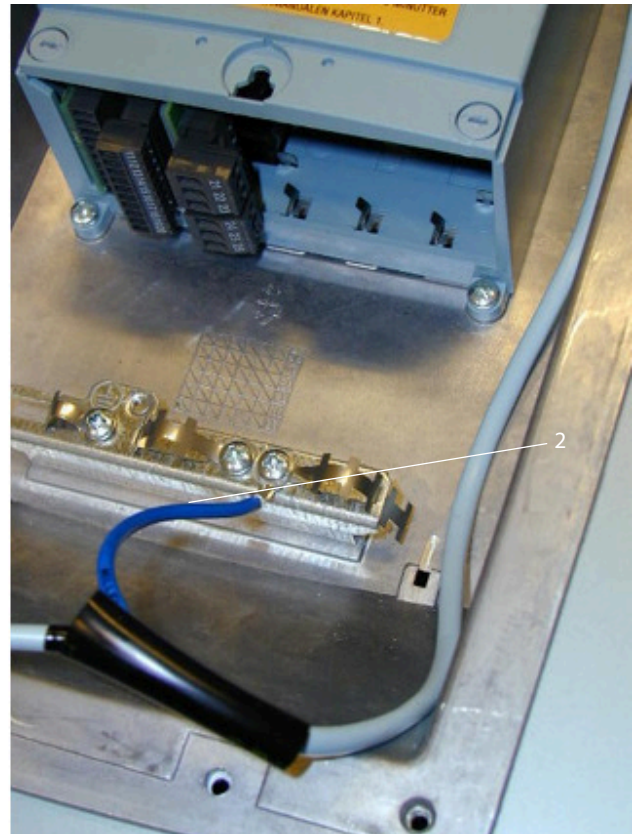

Illustration 2: Connection of VACON cable and the grounding cable, FR4-FR7

- | | |
|---|-----------------|
| 1 | VACON cable |
| 2 | Grounding cable |



e30bk565.10

Illustration 3: Connection of VACON cable and the grounding cable, FR8

- | | |
|---|-----------------|
| 1 | VACON cable |
| 2 | Grounding cable |



e30bk566.10

Illustration 4: Attach the cable cover after connecting the grounding cable, FR8

- | | |
|---|-------------|
| 1 | Cable cover |
|---|-------------|

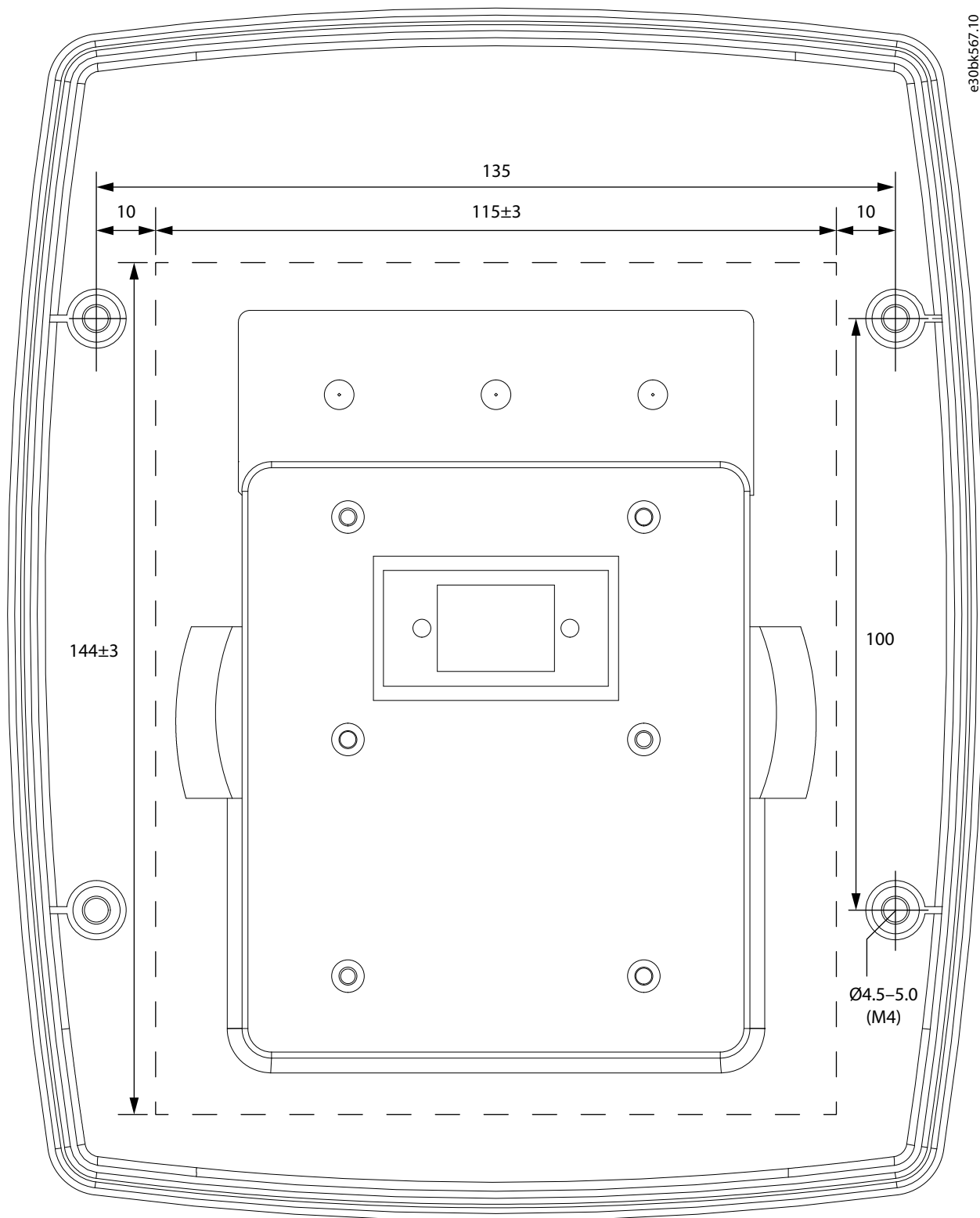

Illustration 5: Door Keypad Mounting Kit, Dimensions in mm(Real Scale)

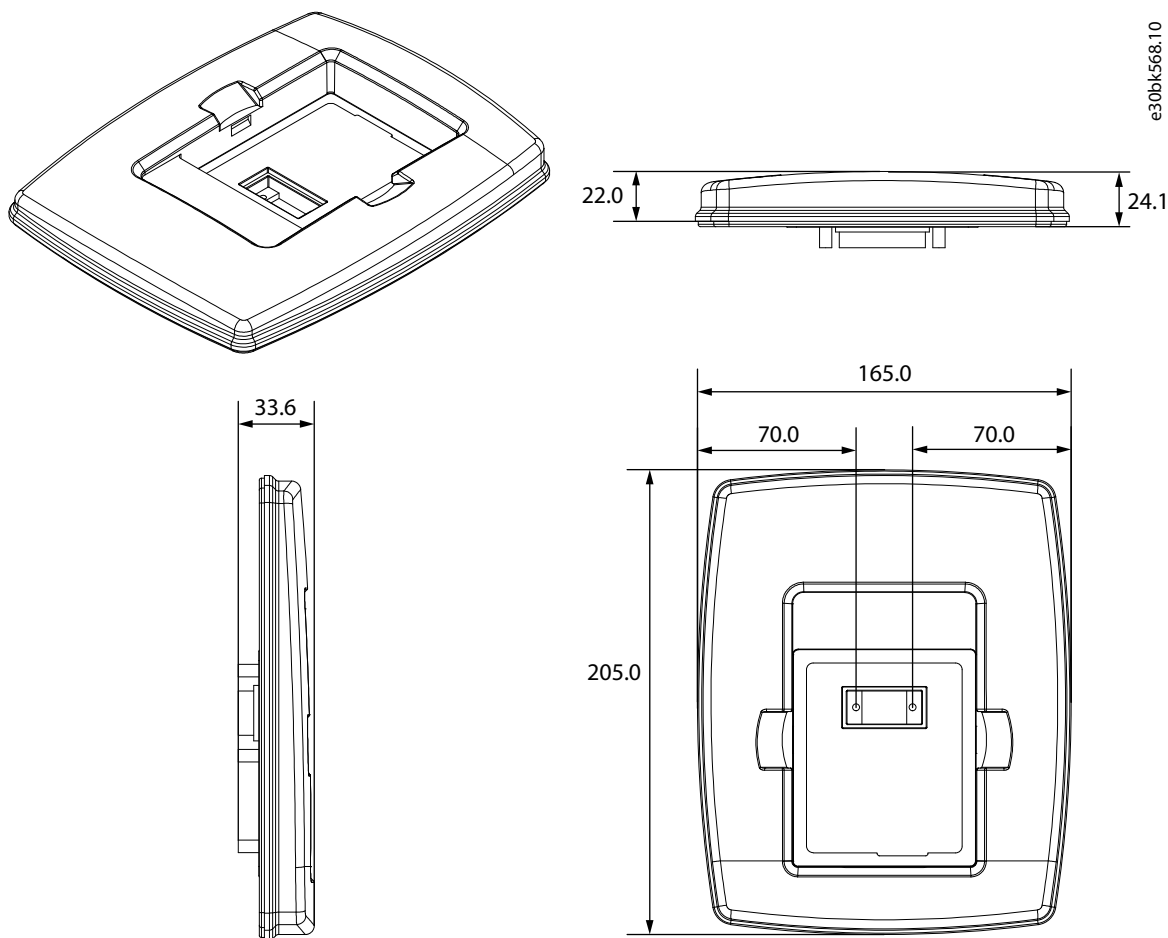

Illustration 6: Door Keypad Mounting Unit, Dimensions in mm

Vacon Ltd, Member of the Danfoss Group
 Runsorintie 7
 FIN-65380 Vaasa
www.danfoss.com

Danfoss can accept no responsibility for possible errors in catalogs, brochures and other printed material. Danfoss reserves the right to alter its products without notice. This also applies to products already on order provided that such alterations can be made without subsequential changes being necessary in specifications already agreed. All trademarks in this material are property of the respective companies. Danfoss and the Danfoss logotype are trademarks of Danfoss A/S. All rights reserved.

