

ENGINEERING
TOMORROW

Danfoss

Application Guide

VACON® 100 INDUSTRIAL



Contents

1	Introduction	11
1.1	Purpose of this Application Guide	11
1.2	Manual and Software Version	11
1.3	Additional Resources	11
1.4	Parameter Table Reading Guide	11
1.5	Functions of the AC Drive	12
1.6	Start-up Quick Guide	13
1.6.1	Start-Up Wizard	13
2	User Interfaces	15
2.1	Description of the Control Panel	15
2.1.1	Control Panel and the Keypad	15
2.1.2	Displays of the Control Panel	15
2.2	Menu Structure	16
2.3	Graphical Display	19
2.3.1	Editing the Text Values	19
2.3.2	Editing the Numerical Values	19
2.3.3	Selecting More than 1 Value	20
2.3.4	Resetting a Fault	20
2.3.5	[FUNCT] Button	20
2.3.5.1	Different Control Places	20
2.3.5.2	Changing the Control Place	21
2.3.5.3	Going into the Control Page	21
2.3.5.4	Changing the Rotation Direction	22
2.3.5.5	Using the Quick Edit Function	22
2.3.6	Copying the Parameters of an AC Drive	23
2.3.7	Comparing the Parameters	23
2.3.8	Reading Help Texts	24
2.3.9	Using the Favourites Menu	25
2.4	Text Display	25
2.4.1	Editing the Text Values	25
2.4.2	Editing the Numerical Values	25
2.4.3	Resetting a Fault	20
2.4.4	[FUNCT] Button	26
2.4.4.1	Different Control Places	20
2.4.4.2	Changing the Control Place	26
2.4.4.3	Going into the Control Page	27

2.4.4.4	Changing the Rotation Direction	27
2.4.4.5	Using the Quick Edit Function	22
2.5	VACON® Live PC Tool	28
3	Applications	29
3.1	Using the Applications	29
3.2	Standard Application	29
3.3	Local/Remote Application	33
3.4	Multi-step Speed Application	37
3.5	PID Control Application	42
3.6	Multi-purpose Application	46
3.7	Motor Potentiometer Application	51
4	Wizards	56
4.1	Application Wizards	56
4.1.1	Standard Application Wizard	56
4.1.2	Local/Remote Application Wizard	56
4.1.3	Multi-step Speed Application Wizard	57
4.1.4	PID Control Application Wizard	57
4.1.5	Multi-purpose Application Wizard	58
4.1.6	Motor Potentiometer Application Wizard	59
4.2	Function Wizards	59
4.2.1	Wizards in Menu 1.1	59
4.2.2	Multi-pump Wizard	60
4.2.3	Fire Mode Wizard	61
5	Monitor Menu	62
5.1	Uses of the Monitor Menu	62
5.2	Multimonitor Monitoring	62
5.2.1	Changing the Items to Monitor	62
5.3	Trend Curve Monitoring	62
5.3.1	Uses of the Trend Curve	62
5.3.2	Changing the Values in Trend Curve Monitoring	62
5.3.3	Stopping the Progression of the Curve	63
5.3.4	Trend Curve Parameters	64
5.4	Basic Monitoring	64
5.4.1	Uses of the Basic Monitoring	64
5.4.2	Basic Monitoring Parameters	64
5.5	I/O Monitoring	65

5.6	Temperature Inputs	65
5.7	Extras and Advanced	66
5.8	Timer Functions Monitoring	67
5.9	PID Controller Monitoring	68
5.10	External PID Controller Monitoring	68
5.11	Multi-pump Monitoring	68
5.12	Monitoring of Maintenance Counters	69
5.13	Fieldbus Process Data Monitoring	69
5.14	Drive Customizer Monitoring	70
5.15	Condition-based Monitoring	71
6	Parameters Menu	73
6.1	Group 3.1: Motor Settings	73
6.2	Group 3.2: Start/Stop Setup	76
6.3	Group 3.3: References	77
6.4	Group 3.4: Ramps and Brakes Setup	82
6.5	Group 3.5: I/O Configuration	83
6.6	Group 3.6: Fieldbus Data	90
6.7	Group 3.7: Prohibit Frequencies	92
6.8	Group 3.8 Supervisions	92
6.9	Group 3.9: Protections	93
6.10	Group 3.10: Automatic Reset	97
6.11	Group 3.11: Application Settings	98
6.12	Group 3.12: Timer Functions	98
6.13	Group 3.13: PID Controller	100
6.14	Group 3.14: External PID Controller	107
6.15	Group 3.15: Multi-pump	110
6.16	Group 3.16: Maintenance Counters	111
6.17	Group 3.17: Fire Mode	111
6.18	Group 3.18: Motor Preheat Parameters	112
6.19	Group 3.19: Drive Customizer	113
6.20	Group 3.20: Mechanical Brake	113
6.21	Group 3.21: Pump Control	114
6.22	Group 3.22: Advanced Harmonic Filter	115
6.23	Group 3.23: Condition-based Monitoring	115
7	Diagnostics Menu	120
7.1	Faults	120
7.1.1	Uses of the Active Faults Submenu	120

7.1.2	Reset Faults	120
7.1.2.1	Resetting Faults with the [BACK/RESET] Button	120
7.1.2.2	Resetting Faults with a Parameter on the Graphical Display	120
7.1.2.3	Resetting Faults with a Parameter on the Text Display	120
7.1.3	Uses of the Fault History	121
7.1.3.1	Examining the Fault History on the Graphical Display	121
7.1.3.2	Examining the Fault History on the Text Display	121
7.2	Software Info	122
7.3	Drive Info	122
7.4	Unit Status	123
8	I/O and Hardware Menu	124
8.1	Basic I/O	124
8.2	Option Board Slots	124
8.3	Real-time Clock	125
8.4	Simple Network Time Protocol (SNTP)	125
8.5	Power Unit Settings	126
8.6	Keypad	126
8.7	Fieldbus	127
8.8	Fieldbus General	129
8.9	STO	130
8.10	Fieldbus Redundancy	130
9	User Settings, Favourites, and User Level Menus	131
9.1	User Settings	131
9.1.1	User Settings Parameters	131
9.1.2	Parameter Back-up Parameters	131
9.1.3	Parameter Compare Parameters	132
9.1.4	License Parameters	132
9.2	Favourites	132
9.2.1	Using the Favourites Menu	132
9.2.2	Adding an Item to the Favourites	132
9.2.3	Removing an Item from the Favourites	132
9.3	User Levels	133
9.3.1	Using the User Levels Menu	133
9.3.2	The User Level Parameters	133
9.3.3	Changing the Access Code of the User Levels	133

10 Monitoring value descriptions	135
10.1 Multimonitor	135
10.2 Basic	136
10.3 I/O	137
10.4 Temperature Inputs	138
10.5 Extras and Advanced	139
10.6 Timer Functions	140
10.7 PID Controller	141
10.8 External PID Controller	141
10.9 Multi-pump	142
10.10 Maintenance Counters	142
10.11 Fieldbus Data	142
10.11.7 Fieldbus Data In	144
10.11.8 Fieldbus Data Out	145
10.12 Drive Customizer	147
10.13 Condition-based Monitoring	147
10.13.1 Baseline Data	147
10.13.2 Stator Winding Monitor	148
10.13.3 Vibration	149
10.13.4 Load	149
11 Parameter descriptions	151
11.2 Trend Curve	151
11.3 Fieldbus Redundancy	152
11.4 Motor Settings	152
11.4.1 Motor Nameplate Parameters	152
11.4.2 Motor Control Parameters	153
11.4.3 Motor Limits	158
11.4.4 Open Loop Parameters	159
11.4.5 I/f Start Function	162
11.4.6 Torque Stabilator Function	162
11.4.7 Advanced Sensorless Control	163
11.5 Start/Stop Setup	165
11.5.1 Start and Stop Commands in Different Control Places	165
11.6 References	173
11.6.1 Frequency Reference	173
11.6.2 Torque Reference	174
11.6.3 Torque Control in Open Loop Control	177

11.6.4	Torque Control in Advanced Sensorless Control	178
11.6.5	Preset Frequencies	178
11.6.6	Motor Potentiometer Parameters	181
11.6.7	Joystick Parameters	182
11.6.8	Jogging Parameters	183
11.7	Ramps and Brakes Setup	185
11.7.1	Ramp 1	185
11.7.2	Ramp 2	186
11.7.3	Start Magnetizing	187
11.7.4	DC Brake	188
11.7.5	Flux Braking	188
11.8	I/O Configuration	188
11.8.1	Programming of Digital and Analog Inputs	188
11.8.1.1	General Information on the Programming	188
11.8.1.2	Programming of Digital Inputs	189
11.8.1.3	Programming of Digital Inputs in the Graphical Display	191
11.8.1.4	Programming of Digital Inputs in the Text Display	191
11.8.1.5	Programming of Analog Inputs	192
11.8.1.6	Programming of Analog Inputs in the Graphical Display	193
11.8.1.7	Programming of Analog Inputs in the Text Display	194
11.8.2	Descriptions of Signal Sources	194
11.8.3	Default Functions of Programmable Inputs	195
11.8.4	Digital Inputs	195
11.8.5	Analog Inputs	200
11.8.6	Digital Outputs	204
11.8.7	Analog Outputs	208
11.9	Fieldbus Data	210
11.10	Prohibit Frequencies	212
11.11	Supervisions	214
11.12	Protections	215
11.12.1	General	215
11.12.2	Motor Thermal Protections	217
11.12.3	Motor Stall Protection	220
11.12.4	Underload Protection	221
11.12.5	Quick Stop	223
11.12.6	Temperature Input Fault	224
11.12.7	AI Low Protection	225
11.12.8	User Defined Fault 1	226

11.12.9 User Defined Fault 2	226
11.13 Automatic Reset	227
11.14 Application Settings	229
11.15 Timer Functions	230
11.15.1 Introduction to Timer Functions	230
11.15.2 Time Channels, Intervals, and Timers	230
11.15.3 Editing an Interval	232
11.16 PID Controller	234
11.16.1 Basic Settings	234
11.16.2 Setpoints	235
11.16.3 Feedback	237
11.16.4 Feedforward	237
11.16.5 Sleep Function	239
11.16.6 Feedback Supervision	241
11.16.7 Pressure Loss Compensation	243
11.16.8 Soft Fill	245
11.16.9 Input Pressure Supervision	247
11.16.10 Frost Protection	249
11.17 External PID Controller	250
11.17.1 Basic Settings	250
11.17.2 Setpoints	252
11.17.3 Feedback	253
11.17.4 Feedback Supervision	253
11.18 Multi-pump Function	255
11.18.1 The Multi-pump Function	255
11.18.2 Overpressure Supervision	261
11.19 Maintenance Counters	261
11.19.1 The Maintenance Counters	261
11.20 Fire Mode	262
11.20.1 The Fire Mode Function	262
11.21 Motor Preheat Function	265
11.22 Drive Customizer	266
11.23 Mechanical Brake	266
11.23.1 The Mechanical Brake Function	266
11.24 Pump Control	268
11.24.1 Auto-Cleaning	268
11.24.2 Jockey Pump	270
11.24.3 Priming Pump	271

11.25 Advanced Harmonic Filter	272
11.26 Condition-based Monitoring	273
11.26.1 Introduction to Condition-based Monitoring	273
11.26.1.1 Stages of Condition-based Monitoring	273
11.26.6 Manual Run	275
11.26.7 Stator Winding Monitoring	275
11.26.8 Threshold Value	275
11.26.9 Warning and Alarm/Fault Stages	277
11.27 Default Values of Parameters in the Different Applications	282
11.28 Settings for Different Motor Types	285
11.28.1 Automatic Tuning of the U/f Curve	285
11.28.2 Manual Tuning of the U/f Curve	286
12 Fault tracing	288
12.1 Fault Types	288
12.2 Alarms and Warnings	288
12.3 Fault Codes	288
12.4 Total and Trip Counters	314
12.4.1 Operating Time Counter	314
12.4.2 Operating Time Trip Counter	315
12.4.3 Run Time Counter	315
12.4.4 Power on Time Counter	316
12.4.5 Energy Counter	316
12.4.6 Energy Trip Counter	317

1 Introduction

1.1 Purpose of this Application Guide

This Application Guide provides information for configuring the system, controlling the AC drive, accessing parameters, programming, and troubleshooting of the AC drive. It is intended for use by qualified personnel. Read and follow the instructions to use the drive safely and professionally. Pay particular attention to the safety instructions and general warnings that are provided in this manual and other documentation delivered with the drive.

1.2 Manual and Software Version

This manual is regularly reviewed and updated. All suggestions for improvement are welcome. The original language of this manual is English.

Table 1: Manual and Software Version

Edition	Software version
DPD00927K	FW0072V033

1.3 Additional Resources

Other resources are available to understand advanced AC drive functions and operation.

- VACON®100 Wall-mounted Drives Operating Guide
- VACON®100 Enclosed Drives Installation Manual
- VACON®100 IP00 Drive Modules Installation Manual
- VACON®100 X Installation Manual
- Instructions for operation with option boards and other optional equipment.

Supplementary publications and manuals are available from Danfoss.

For US and Canadian markets:

NOTE! Download the English and French product guides with applicable safety, warning and caution information from <https://www.danfoss.com/en/service-and-support/>.

REMARQUE Vous pouvez télécharger les versions anglaise et française des guides produit contenant l'ensemble des informations de sécurité, avertissements et mises en garde applicables sur le site <https://www.danfoss.com/en/service-and-support/>.

1.4 Parameter Table Reading Guide

This manual includes a large quantity of parameter tables. These instructions tell you how to read the tables.

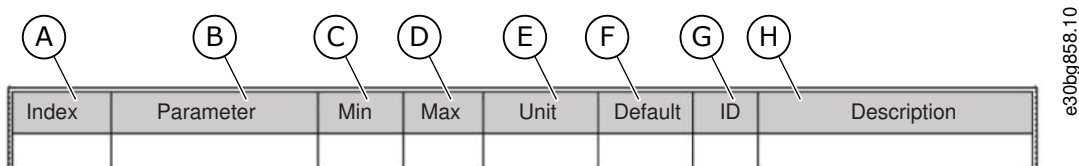

Illustration 1: Parameter Table Reading Guide

A	The location of the parameter in the menu, that is, the parameter number.	E	The unit of the value of the parameter. The unit shows if it is available.
B	The name of the parameter.	F	The value that was set in the factory.
C	The minimum value of the parameter.	G	The ID number of the parameter.
D	The maximum value of the parameter.	H	A short description of the values of the parameter and/or its function.

1.5 Functions of the AC Drive

- Easy setup functions
 - Applications with preset parameters and I/O configuration for your process: Standard, Local/Remote, Multi-step speed, PID control, Multi-purpose, or Motor potentiometer
 - Start-up wizards for fast and easy parameterization
- Navigation functions
 - The [FUNCT] button for an easy change between the local and the remote control place (I/O or fieldbus)
 - A control page to operate and monitor of the most important values quickly
- Advanced monitoring functions
 - Multimonitor
 - Trend curve
- Fieldbus and I/O control
- Motor control
 - Open loop control with frequency, speed, and torque reference
 - Advanced sensorless control mode
 - Support for induction, permanent magnet, and synchronous reluctance motors
 - Identification run for setup of motor parameters
 - Many advanced functions for motor control setting, such as load drooping
 - Flux and DC brake
- Start and stop logic configuration
- Reference selection and handling
 - 8 preset frequencies
 - Motor potentiometer functions
 - A joystick control
 - A jogging function
 - 2 programmable ramp times
 - 3 ranges of prohibited frequencies
 - A forced stop
- PID control
 - An external PID controller is available. Use it, for example, to control a valve with the I/O of the AC drive.
 - A sleep mode function that automatically enables and disables the operation of the drive to save energy
 - A 2-zone PID controller with 2 different feedback signals: minimum and maximum control
 - 2 setpoint sources for the PID control. Selection to be made with a digital input.
 - A function for PID setpoint boost
 - A feedforward function to make the response to the process changes better
- Pump control
 - Multi-pump control
 - Priming pump control, jockey pump control, pump impeller auto-cleaning, pump input pressure supervision, and frost protection function
- Mechanical brake control
- Timer functions and a real-time clock and (an optional battery is necessary)
- Fire mode
- Diagnostic and maintenance functions
 - Variety of configurable protection functions including user-defined faults
 - Supervision functions for frequency and motor variables and analog inputs

- Motor overload protections
- An automatic reset
- Different preheat modes to prevent condensation problems
- Maintenance counters
- Drive Customizer for custom logic programming
- Control, parametrization, and diagnostics via PC-tools

1.6 Start-up Quick Guide

There are 6 applications available for the product. When an application is selected, a group of parameters get their preset values. The selection of the application makes the commissioning of the drive easy and reduces the manual work with the parameters. It is also possible to edit these parameters later.

⚠ W A R N I N G ⚠

ACCIDENTAL START BECAUSE OF CHANGE OF SETTINGS

Running the Startup wizard, changing the application or the software can cause the I/O functions to change.

- Disconnect the motor from the drive if an accidental start can be dangerous.

The available applications:

- Standard application ([3.2 Standard Application](#))
- Local/remote application ([3.3 Local/Remote Application](#))
- Multi-step speed application ([3.4 Multi-step Speed Application](#))
- PID control application ([3.5 PID Control Application](#))
- Multi-purpose application ([3.6 Multi-purpose Application](#))
- Motor potentiometer application ([3.7 Motor Potentiometer Application](#))

Wizards make it more convenient to use the AC drive. There is a start-up wizard (see [1.6.1 Start-Up Wizard](#)), 6 applications wizards (see [4.1 Application Wizards](#)), and 2 function wizards (see [4.2.2 Multi-pump Wizard](#) and [4.2.3 Fire Mode Wizard](#)).

1.6.1 Start-Up Wizard

The Start-up wizard asks for necessary data for the drive to control the procedure.

Procedure

1. Select language (P6.1).

If a battery is installed, the steps 2–5 are shown.

2. Set daylight saving time (P5.5.5). (Russia, US, EU, or OFF)
3. Set time (P5.5.2).
4. Set year (P5.5.4).
5. Set date (P5.5.3).
6. Run Startup wizard?

If the selection is No, the Start-up wizard ends.

7. Select an application (P1.2 Application, ID212).
8. Set a value for P3.1.2.2 Motor Type (so that it agrees with the nameplate).
9. Set a value for P3.1.1.1 Motor Nominal Voltage (so that it agrees with the nameplate).
10. Set a value for P3.1.1.2 Motor Nominal Frequency (so that it agrees with the nameplate).
11. Set a value for P3.1.1.3 Motor Nominal Speed (so that it agrees with the nameplate).
12. Set a value for P3.1.1.4 Motor Nominal Current.
13. Set a value for P3.1.1.5 Motor Cos Phi.

If parameter P3.1.2.2 Motor Type is set to *Induction Motor*, this step is shown. If the selection is *PM Motor*, the value of parameter P3.1.1.5 Motor Cos Phi is set to 1.00 and the wizard goes directly to step 14.

14. Set a value for P3.3.1.1 Minimum Frequency Reference.
15. Set a value for P3.3.1.2 Maximum Frequency Reference.

16. Set a value for P3.4.1.2 Acceleration Time 1.
17. Set a value for P3.4.1.3 Deceleration Time 1.
18. Run the Application wizard?
 - a. To continue to the application wizard, set the selection to Yes and push the [OK] button. See the description of the different application wizards in chapter [4.1 Application Wizards](#).



After these selections, the Start-up wizard is completed. To start the Start-up wizard again, there are 2 alternatives. Go to the parameter P6.5.1 Restore Factory Defaults or to the parameter B1.1.1 Start-up Wizard. Then set the value to Activate.

2 User Interfaces

2.1 Description of the Control Panel

2.1.1 Control Panel and the Keypad

The control panel is the interface between the AC drive and the user. With the control panel, it is possible to control the speed of a motor and monitor the status of the AC drive. It is also possible to set the parameters of the AC drive.

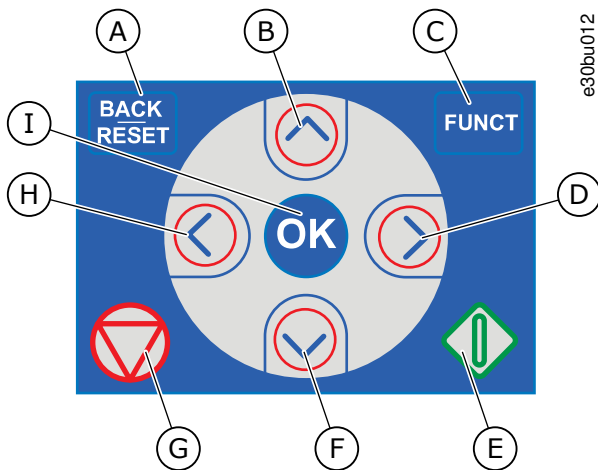

Illustration 2: Buttons of the VACON® 100 Keypad

A	The [BACK/RESET] button. Use it to move back in the menu, exit the Edit mode, reset a fault.	F	The arrow button DOWN. Use it to scroll the menu down and to decrease a value.
B	The arrow button UP. Use it to scroll up the menu and to increase a value.	G	The STOP button.
C	The [FUNCT] button. Use it to change the rotation direction of the motor, access the control page, and change the control place.	H	The arrow button LEFT. Use it to move the cursor left.
D	The arrow button RIGHT.	I	The [OK] button. Use it to go into an active level or item, or to accept a selection.
E	The START button.		

2.1.2 Displays of the Control Panel

There are 2 display types: the graphical display and the text display. The control panel always has the same keypad and buttons. The display shows this data.

- The status of the motor and the drive.
- Faults in the motor and in the drive.
- Your location in the menu structure.

If the text in the text display is too long for the display, the text scrolls to show the full text string. Some functions are only available in the graphical display.

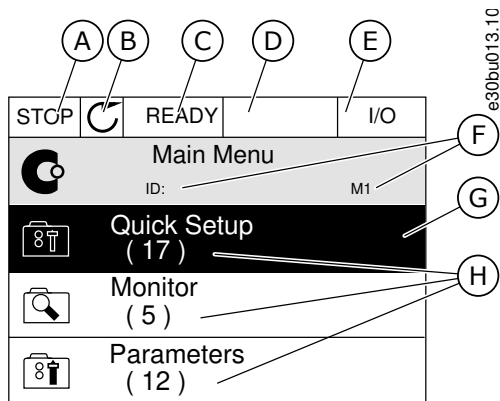

Illustration 3: Graphical Display of the Control Panel

A	The first status field: <i>STOP/RUN</i>	E	The control place field: <i>PC//O/KEYPAD/ FIELDBUS</i>
B	The rotation direction of the motor	F	The location field: the ID number of the parameter and the current location in the menu
C	The second status field: <i>READY/NOT READY/FAULT</i>	G	An activated group or item
D	The alarm field: <i>ALARM/-</i>	H	The number of items in the group in question

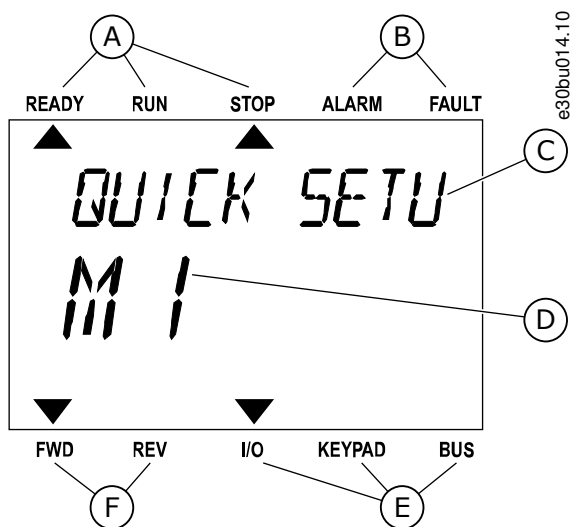

Illustration 4: Text Display of the Control Panel

A	The indicators of status	D	The current location in the menu
B	The indicators of alarm and fault	E	The indicators of the control place
C	The name of the group or item of the current location	F	The indicators of the rotation direction

2.2 Menu Structure

The data of the AC drive is in menus and submenus. To move between the menus, use the arrow buttons Up and Down in the keypad. To go into a group or an item, push the [OK] button. To go back to the previous level, push the [BACK/RESET] button. On the display, current location in the menu shows, for example M3.2.1. The display also shows the name of the group or item in the current location.

Table 2: Menu Structure

Menu	Function
M1 Quick setup	Wizards (Content depends on P1.2 Application.)
M2 Monitor	Multimonitor
	Trend curve
	Basic
	I/O
	Temperature inputs
	Extras/Advanced
	Timer functions
	PID controller
	External PID controller
	Multi-pump
	Maintenance counters
	Fieldbus data
	Drive customizer
	Condition-based monitoring
M3 Parameters	Motor settings
	Start/Stop setup
	References
	Ramps and brakes
	I/O Configuration
	Fieldbus data
	Prohibit frequencies
	Supervisions
	Protections
	Automatic reset
	Application settings
	Timer functions
	PID controller
	External PID controller
	Multi-pump
	Maintenance counters
	Fire mode

Menu	Function
	Motor preheat
	Drive customizer
	Mechanical brake
	Pump control
	Advanced harmonic filter
	Condition-based monitoring
M4 Diagnostics	Active faults
	Reset faults
	Fault history
	Total counters
	Trip counters
	Software info
	Drive info
	Unit status
M5 I/O and Hardware	Basic I/O
	Slot C
	Slot D
	Slot E
	Real-time clock
	Power unit settings
	Keypad
	RS485
	Ethernet
	Fieldbus general
M6 User settings	Language selections
	Parameter back-up
	Drive name
	Parameter compare
	Licenses
M7 Favourites	See 9.2.1 Using the Favourites Menu.
M8 User levels	See 9.3.1 Using the User Levels Menu.

2.3 Graphical Display

2.3.1 Editing the Text Values

This topic gives instructions on how to edit the text values on the graphical display.

Procedure

1. Find the parameter with the arrow buttons.
2. To go to the *Edit* mode, push the [OK] button 2 times or push the arrow button Right.

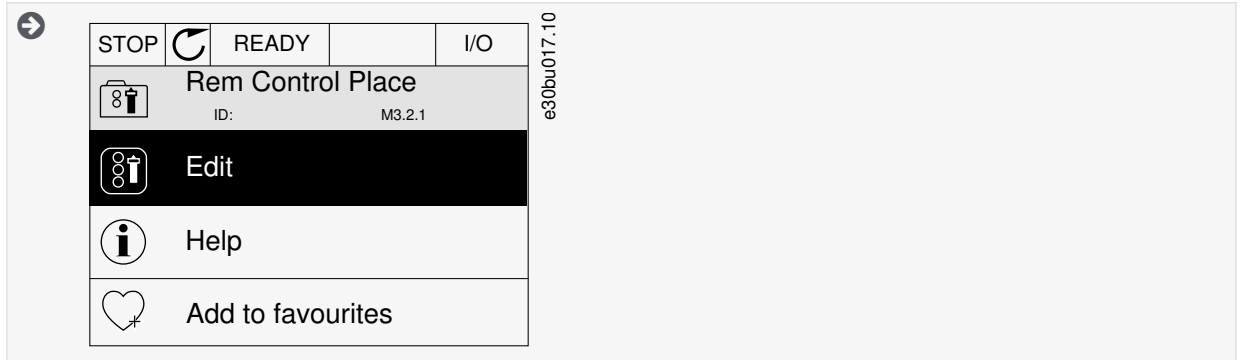

3. To set a new value, push the arrow buttons Up and Down.

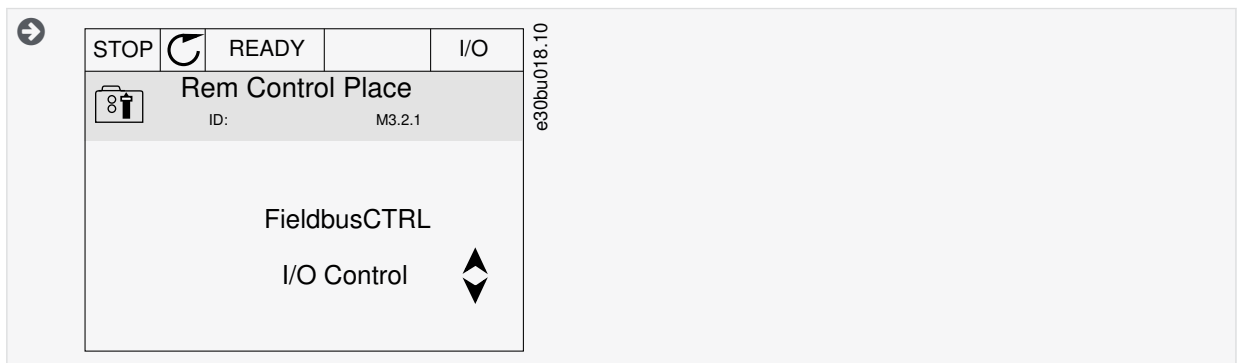

4. To accept the change, push the [OK] button. To ignore the change, use the [BACK/RESET] button.

2.3.2 Editing the Numerical Values

This topic gives instructions on how to edit the numerical values on the graphical display.

Procedure

1. Find the parameter with the arrow buttons.
2. To go to the *Edit* mode, push the [OK] button 2 times or push the arrow button Right.
3. Move from digit to digit with the arrow buttons Left and Right. Change the digits with the arrow buttons Up and Down.

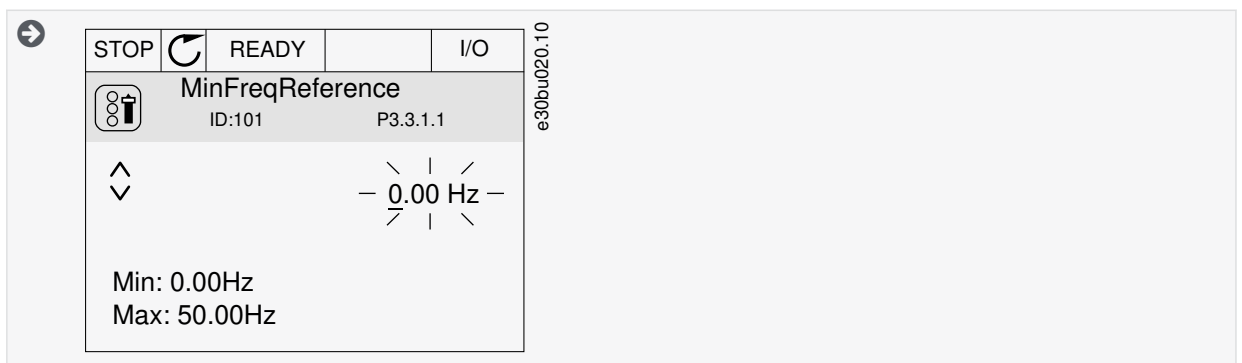

4. To accept the change, push the [OK] button. To ignore the change, use the [BACK/RESET] button.

2.3.3 Selecting More than 1 Value

With some parameters, more than 1 value can be selected. Select a checkbox at each necessary value.

Procedure

1. Find the parameter. There is a symbol on the display when a checkbox selection is possible.

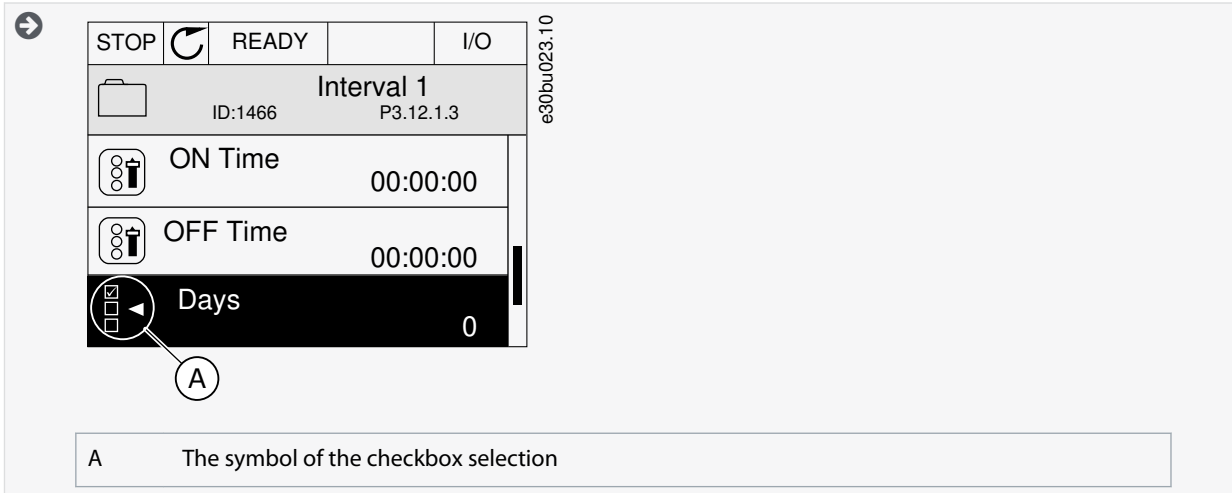

2. To move in the list of values, use the arrow buttons Up and Down.
3. To add a value into your selection, select the box that is next to it with the arrow button Right.

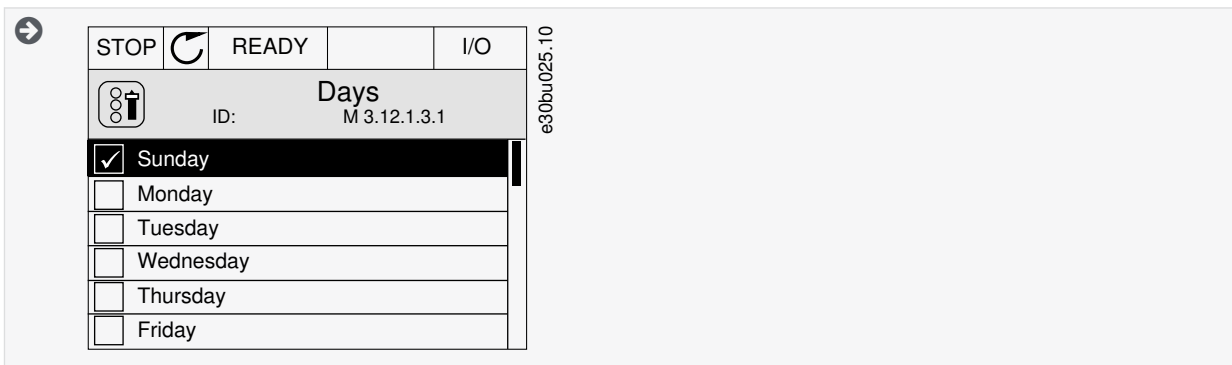

2.3.4 Resetting a Fault

To reset a fault, use the [BACK/RESET] button or the parameter Reset Faults. See [7.1.2 Reset Faults](#).

2.3.5 [FUNCT] Button

The [FUNCT] button can be used for 4 functions.

- To have access to the Control page.
- To change easily between the Local and Remote control places.
- To change the rotation direction.
- To edit quickly a parameter value.

2.3.5.1 Different Control Places

The selection of the control place determines from where the AC drive takes the start and stop commands. All the control places have a parameter for the selection of the frequency reference source. The Local control place is always *Keypad*. The Remote control place is *I/O* or *Fieldbus*. The status bar of the display shows the current control place.

It is possible to use *I/O A*, *I/O B*, and *Fieldbus* as Remote control places. *I/O A* and *Fieldbus* have the lowest priority. Select them with P3.2.1 (Remote Control Place). *I/O B* can bypass the Remote control places *I/O A* and *Fieldbus* with a digital input. Select the digital input with parameter P3.5.1.7 (*I/O B* Control Force).

Keypad is always used as a control place when the control place is Local. Local control has higher priority than Remote control. For example, if parameter P3.5.1.7 bypasses the control place with a digital input, and Local is selected in Remote control, *Keypad* becomes the control place. Use the [FUNCT] button or P3.2.2 Local/Remote to change between the Local and Remote control.

2.3.5.2 Changing the Control Place

This topic gives instructions on how to change the control place on the control panel.

Procedure

1. Anywhere in the menu structure, push the [FUNCT] button.
2. To select Local/Remote, use the arrow buttons Up and Down. Push the [OK] button.

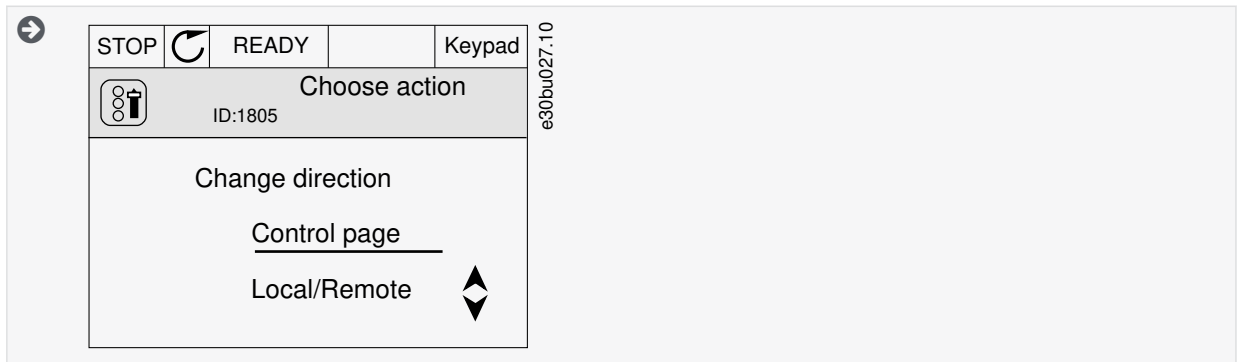

3. To select Local or Remote, use the arrow buttons Up and Down again. To accept the selection, push the [OK] button.

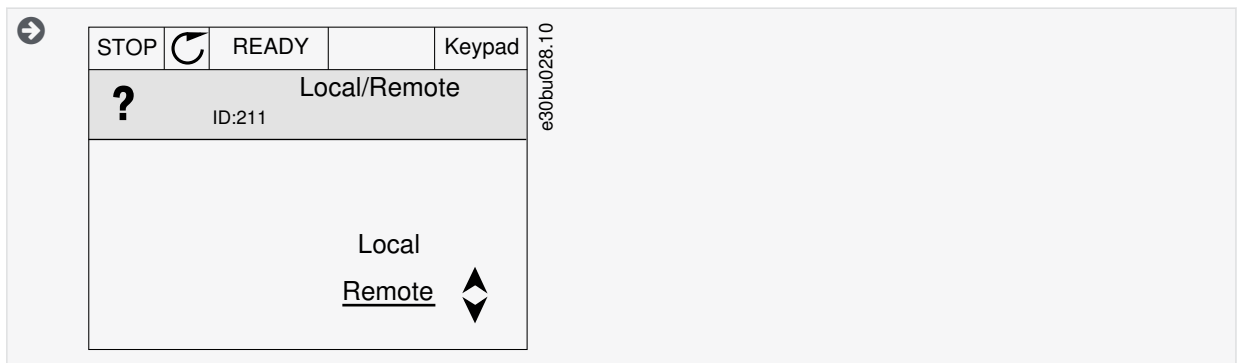

4. If Remote control place is changed to Local, that is, *Keypad*, give a keypad reference.

➡ After the selection, the display goes back into the same location where it was when the [FUNCT] button was pushed.

2.3.5.3 Going into the Control Page

It is easy to monitor the most important values in the *Control page*.

See more information about Keypad Reference in [6.3 Group 3.3: References](#). If other control places or reference values are used, the display shows the frequency reference, which cannot be edited. The other values on the page are *Multimonitor* values. These values can be selected (see [5.2.1 Changing the Items to Monitor](#)).

Procedure

1. Anywhere in the menu structure, push the [FUNCT] button.
2. To select the *Control page*, push the arrow buttons Up and Down. Go in with the [OK] button.

➡ The *Control page* opens.

3. With the Local control place and the keypad reference selected, P3.3.1.8 Keypad Reference can be set with the [OK] button.

- To change the digits in the value, push the arrow buttons Up and Down. Accept the change with the [OK] button.

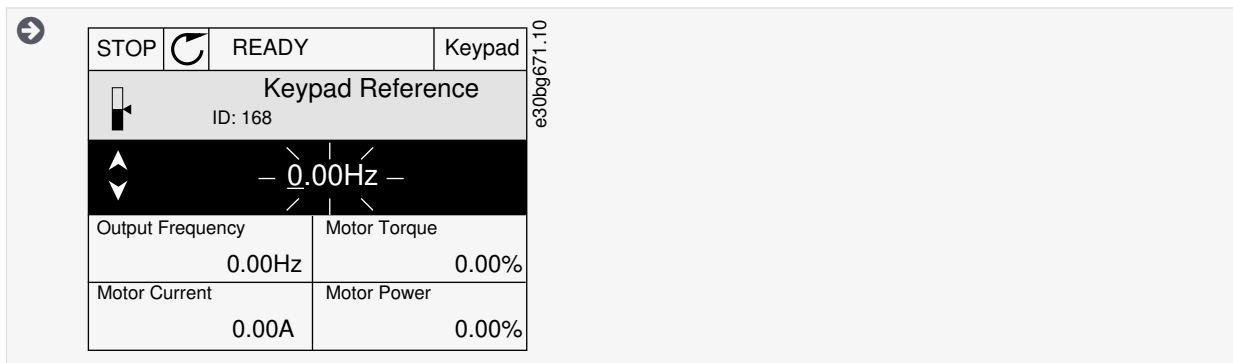

2.3.5.4 Changing the Rotation Direction

The rotation direction of the motor can be changed quickly with the [FUNCT] button.

NOTICE

The command *Change direction* is available in the menu only if the current control place is Local.

Procedure

- Anywhere in the menu structure, push the [FUNCT] button.
- To select *Change direction*, push the arrow buttons Up and Down. Push the [OK] button.
- Select a new rotation direction.

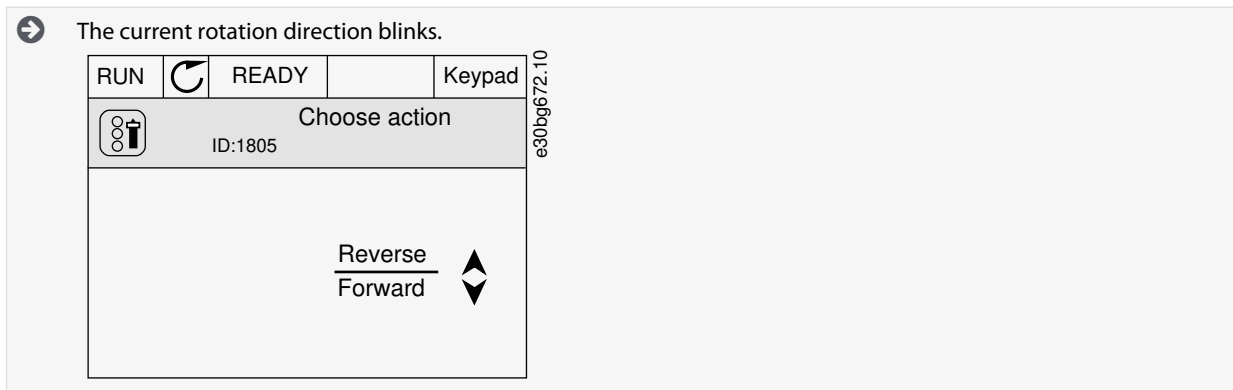

- Push the [OK] button.

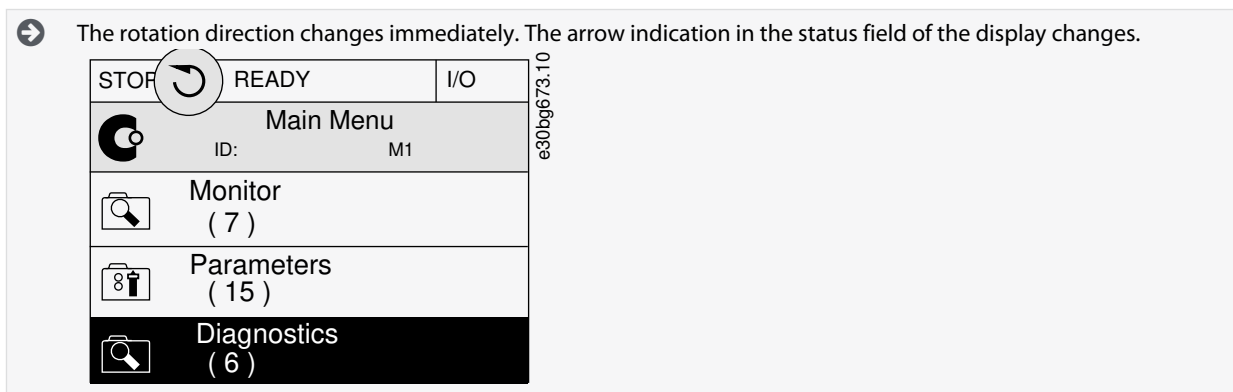

2.3.5.5 Using the Quick Edit Function

With the *Quick Edit* function, a parameter can be accessed quickly by typing the ID number of the parameter.

Procedure

- Anywhere in the menu structure, push the [FUNCT] button.

2. Push the arrow buttons Up and Down to select *Quick Edit* and accept with the [OK] button.
3. Write the ID number of a parameter or monitoring value. Push [OK].

➡ The display shows the parameter value in the edit mode and the monitoring value in the monitoring mode.

2.3.6 Copying the Parameters of an AC Drive

Use this function to copy parameters from a drive to another. Before downloading parameters from the control panel to the drive, stop the drive.

N O T I C E

This function is available only in the graphical display.

Procedure

1. Save the parameters to the control panel.
 - a. Go into the *User settings* menu.
 - b. Go into the *Parameter backup* submenu.

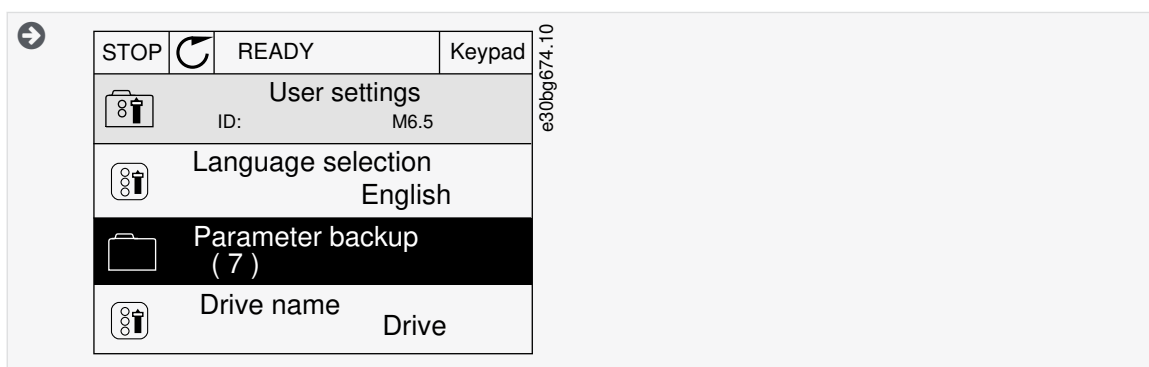

- c. Use the arrow buttons Up and Down to select a function. Accept the selection with the [OK] button.

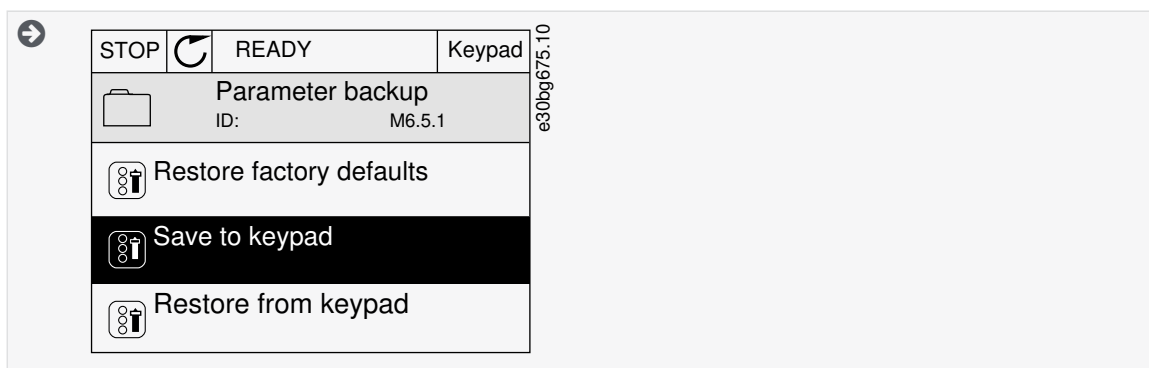

The command *Restore factory defaults* brings back the parameter settings that were made at the factory. Use the command *Save to keypad* to copy all the parameters to the control panel. The command *Restore from keypad* copies all the parameters from the control panel to the drive.

2. Detach the control panel and connect it to another drive.
3. Download the parameters to the new drive with the command *Restore from keypad*.

2.3.7 Comparing the Parameters

Use this function to compare the current parameter set with one of these 4 sets. See more about these parameters in [9.1.2 Parameter Back-up Parameters](#).

- *Set 1* (P6.5.4 Save to Set 1)
- *Set 2* (P6.5.6 Save to Set 2)
- *Defaults* (P6.5.1 Restore Factory Defaults)
- *Keypad set* (P6.5.2 Save to Keypad)

N O T I C E

If the parameter set with which the current set is compared was not saved, the display shows the text *Comparing failed*.

Procedure

1. Go into the *User settings* menu.
2. Go into the *Parameter Compare* function.

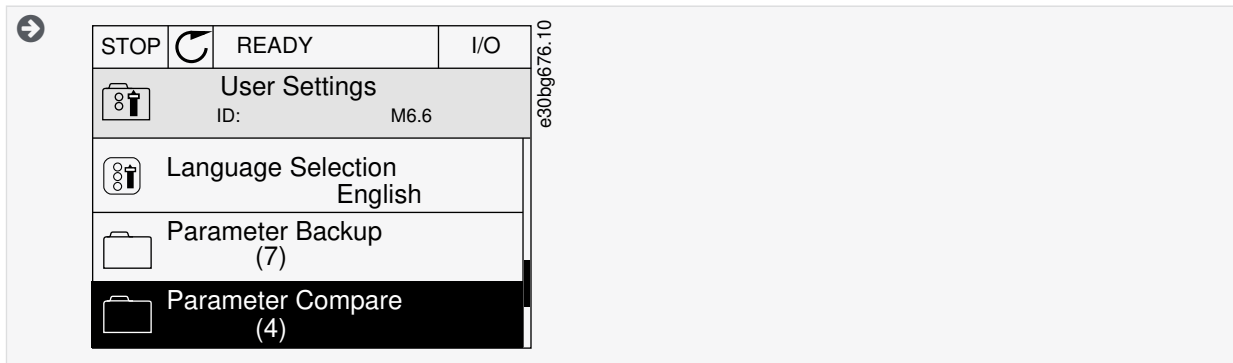

3. Select the pair of sets. Push [OK] to accept the selection.

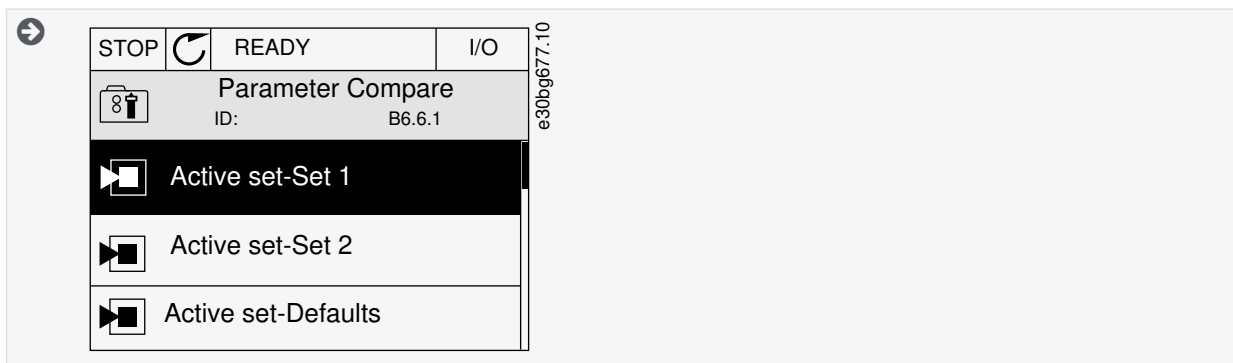

4. Select *Active* and push [OK].
5. Examine the comparing between the current values and the values of the other set.

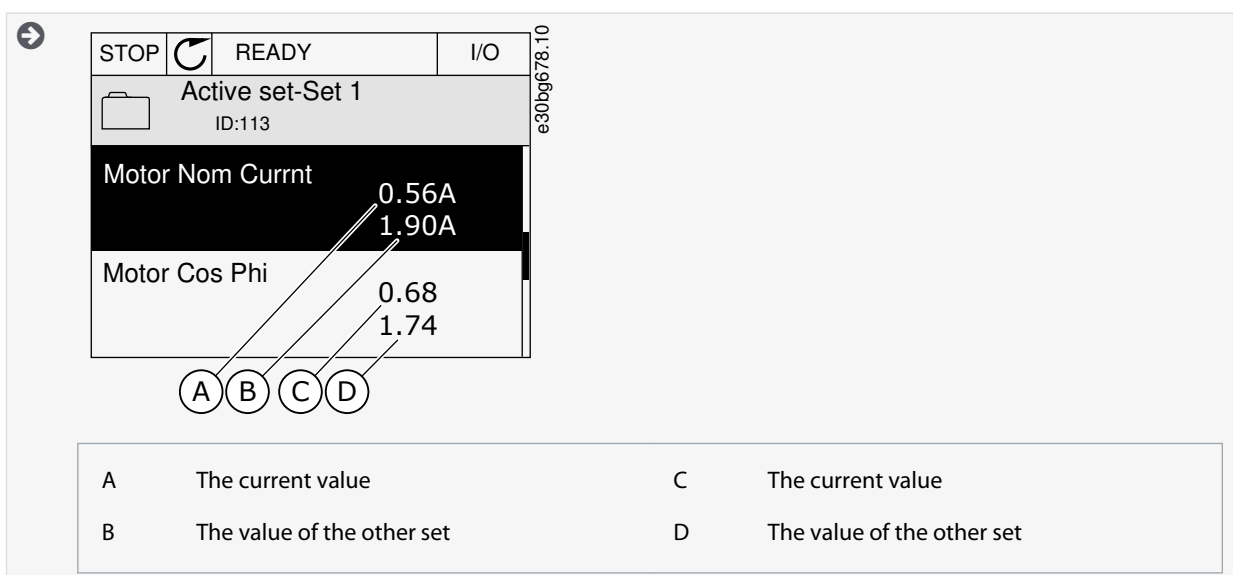

2.3.8 Reading Help Texts

The graphical display can show help texts on many topics. All the parameters have a help text. The help texts are also available for the faults, alarms, and the start-up wizard.

NOTICE

The help texts are always in English.

Procedure

1. Find the item to read.
2. Use the arrow buttons Up and Down to select *Help*.

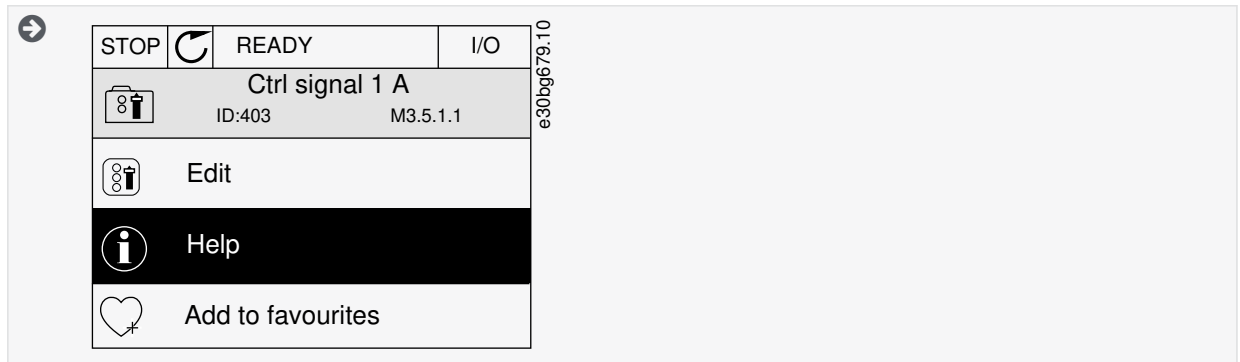

3. To open the help text, push the [OK] button.

2.3.9 Using the Favourites Menu

If the same items are used frequently, add them into *Favourites*. Collect a set of parameters or monitoring signals from all the control panel menus. See [9.2.2 Adding an Item to the Favourites](#).

2.4 Text Display

2.4.1 Editing the Text Values

This topic gives instructions on how to edit text values on the text display.

Procedure

1. Find the parameter with the arrow buttons.
2. To go to the Edit mode, push the [OK] button.
3. To set a new value, push the arrow buttons Up and Down.

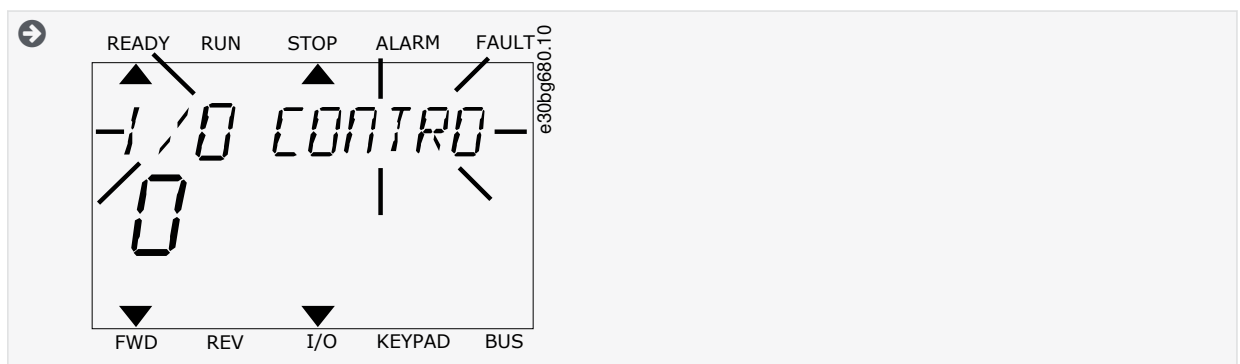

4. Accept the change with the [OK] button. To ignore the change, use the [BACK/RESET] button.

2.4.2 Editing the Numerical Values

This topic gives instructions on how to edit the numerical values on the text display.

Procedure

1. Find the parameter with the arrow buttons.
2. Go to the Edit mode.
3. Move from digit to digit with the arrow buttons Left and Right. Change the digits with the arrow buttons Up and Down.
4. Accept the change with the [OK] button. To ignore the change, use the [BACK/RESET] button.

2.4.3 Resetting a Fault

To reset a fault, use the [BACK/RESET] button or the parameter Reset Faults. See [7.1.2 Reset Faults](#).

2.4.4 [FUNCT] Button

The [FUNCT] button can be used for 4 functions.

- To have access to the *Control page*.
- To change easily between the Local and Remote control places.
- To change the rotation direction.
- To edit quickly a parameter value.

2.4.4.1 Different Control Places

The selection of the control place determines from where the AC drive takes the start and stop commands. All the control places have a parameter for the selection of the frequency reference source. The Local control place is always *Keypad*. The Remote control place is *I/O* or *Fieldbus*. The status bar of the display shows the current control place.

It is possible to use *I/O A*, *I/O B*, and *Fieldbus* as Remote control places. *I/O A* and *Fieldbus* have the lowest priority. Select them with P3.2.1 (Remote Control Place). *I/O B* can bypass the Remote control places *I/O A* and *Fieldbus* with a digital input. Select the digital input with parameter P3.5.1.7 (*I/O B Control Force*).

Keypad is always used as a control place when the control place is Local. Local control has higher priority than Remote control. For example, if parameter P3.5.1.7 bypasses the control place with a digital input, and Local is selected in Remote control, *Keypad* becomes the control place. Use the [FUNCT] button or P3.2.2 Local/Remote to change between the Local and Remote control.

2.4.4.2 Changing the Control Place

This topic gives instructions on how to change the control place on the control panel.

Procedure

1. Anywhere in the menu structure, push the [FUNCT] button.
2. To select *Local/Remote*, use the arrow buttons Up and Down. Push the [OK] button.

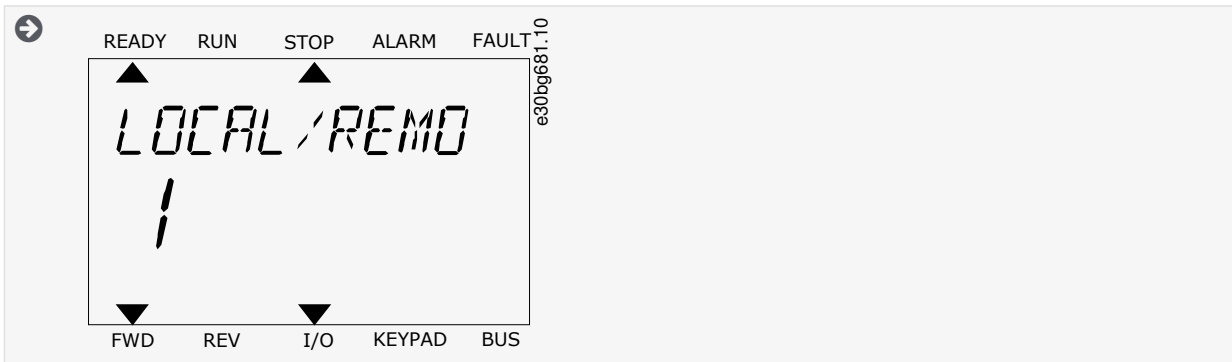

3. To select *Local* or *Remote*, use the arrow buttons Up and Down again. To accept the selection, push the [OK] button.

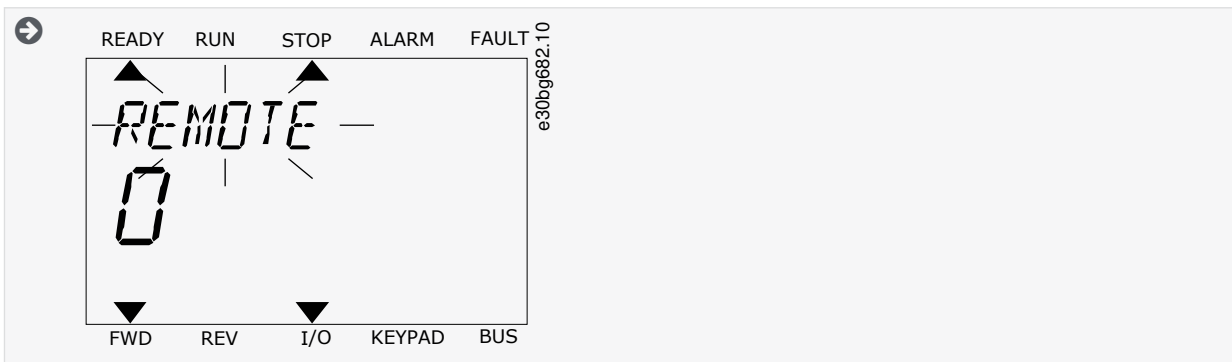

4. If *Remote* control place is changed to *Local*, that is, the keypad, give a keypad reference.

➡ After the selection, the display goes back into the same location where it was when the [FUNCT] button was pushed.

2.4.4.3 Going into the Control Page

It is easy to monitor the most important values in the *Control page*.

See more information about Keypad Reference in [6.3 Group 3.3: References](#). If other control places or reference values are used, the display shows the frequency reference that cannot be edited. The other values on the page are *Multimonitor* values. These values can be selected (see [5.2.1 Changing the Items to Monitor](#)).

Procedure

1. Anywhere in the menu structure, push the [FUNCT] button.
2. To select the *Control page*, push the arrow buttons Up and Down. Go in with the [OK] button.

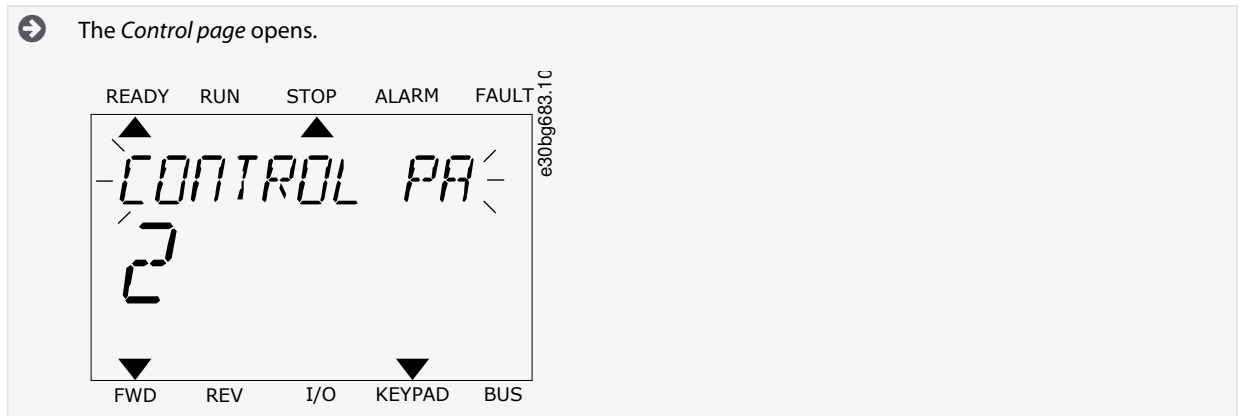

3. If the Local control place and the keypad reference are used, P3.3.1.8 Keypad Reference can be set with the [OK] button.

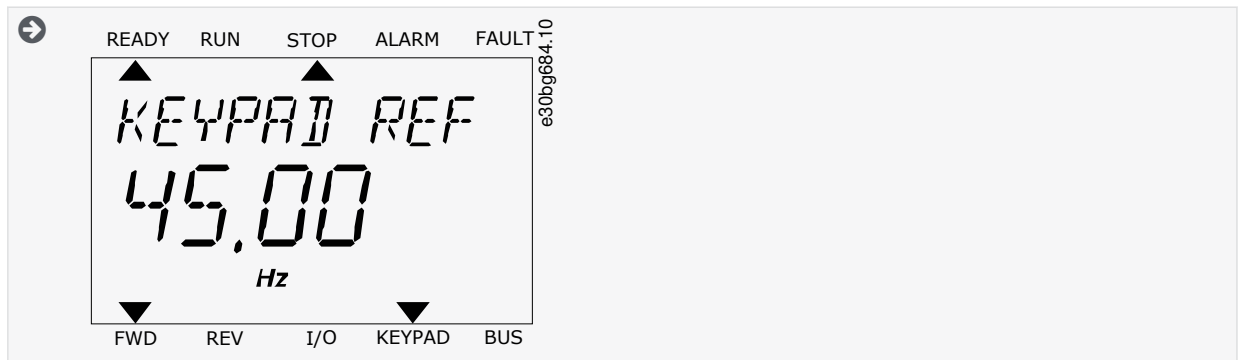

2.4.4.4 Changing the Rotation Direction

The rotation direction of the motor can be changed quickly with the [FUNCT] button.

NOTICE

The command *Change direction* is available in the menu only if the current control place is Local.

Procedure

1. Anywhere in the menu structure, push the [FUNCT] button.
2. To select *Change direction*, push the arrow buttons Up and Down. Push the [OK] button.
3. Select a new rotation direction.

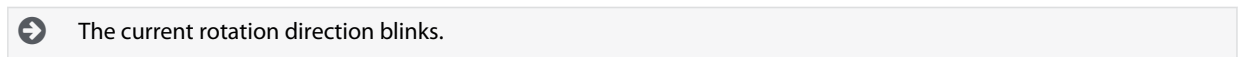

4. Push the [OK] button.

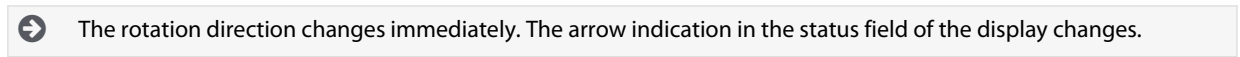

2.4.4.5 Using the Quick Edit Function

With the *Quick Edit* function, a parameter can be accessed quickly by typing the ID number of the parameter.

Procedure

1. Anywhere in the menu structure, push the [FUNCT] button.
2. Push the arrow buttons Up and Down to select *Quick Edit* and accept with the [OK] button.
3. Write the ID number of a parameter or monitoring value. Push [OK].

➔ The display shows the parameter value in the edit mode and the monitoring value in the monitoring mode.

2.5 VACON® Live PC Tool

VACON® Live is a PC tool for start commissioning and maintenance of the VACON® AC drives. VACON® Live can be downloaded from <https://www.danfoss.com>.

The VACON® Live PC tool includes these functions.

- Parameterization, monitoring, drive info, data logger, and so on.
- The software download tool VACON® Loader
- Serial communication and Ethernet support
- Windows XP, Vista, 7, 8, and 10 support
- 17 languages: English, German, Spanish, Finnish, French, Italian, Russian, Swedish, Chinese, Czech, Danish, Dutch, Polish, Portuguese, Romanian, Slovak and Turkish

Make the connection between the AC drive and the PC tool with the VACON® serial communication cable. The serial communication drivers are installed automatically during the installation of VACON® Live. After the cable is installed, VACON® Live finds the connected drive automatically.

See more on how to use VACON® Live in the help menu of the program.

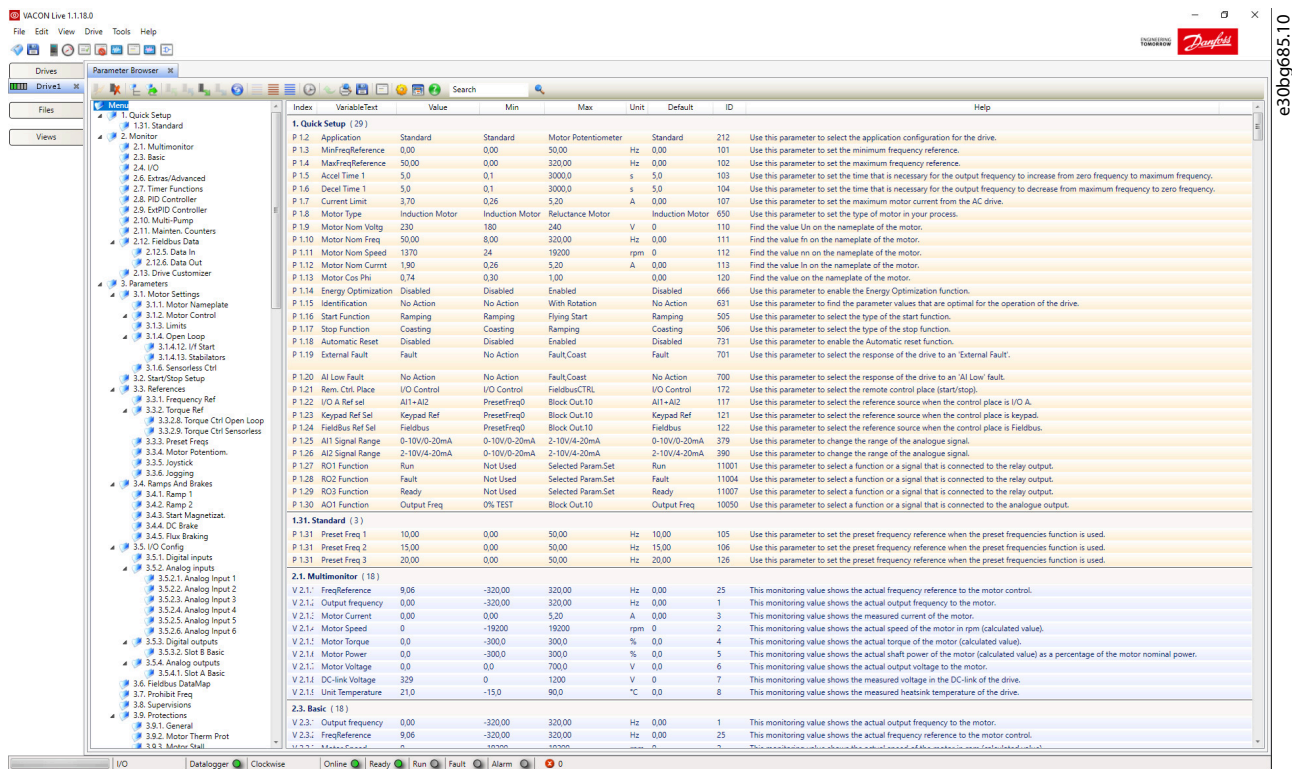

Illustration 5: The VACON® Live PC Tool

3 Applications

3.1 Using the Applications

Use the parameter P1.2 (Application) to select an application for the drive. Immediately when the parameter P1.2 changes, parameter groups get their preset values.

3.2 Standard Application

Use the Standard application in speed-controlled processes where no special functions are necessary, for example pumps, fans, or conveyors.

It is possible to control the drive from the control panel (keypad), Fieldbus, or I/O terminal.

When the drive is controlled with the I/O terminal, the frequency reference signal is connected to AI1 (0...10 V) or AI2 (4...20 mA). The connection depends on the type of the signal. There are also 3 preset frequency references available. The preset frequency references can be activated with DI4 and DI5. The start/stop signals of the drive are connected to DI1 (start forward) and DI2 (start reverse).

It is possible to configure all the drive outputs freely in all the applications. There is 1 analog output (Output Frequency) and 3 relay outputs (Run, Fault, Ready) available on the basic I/O board.

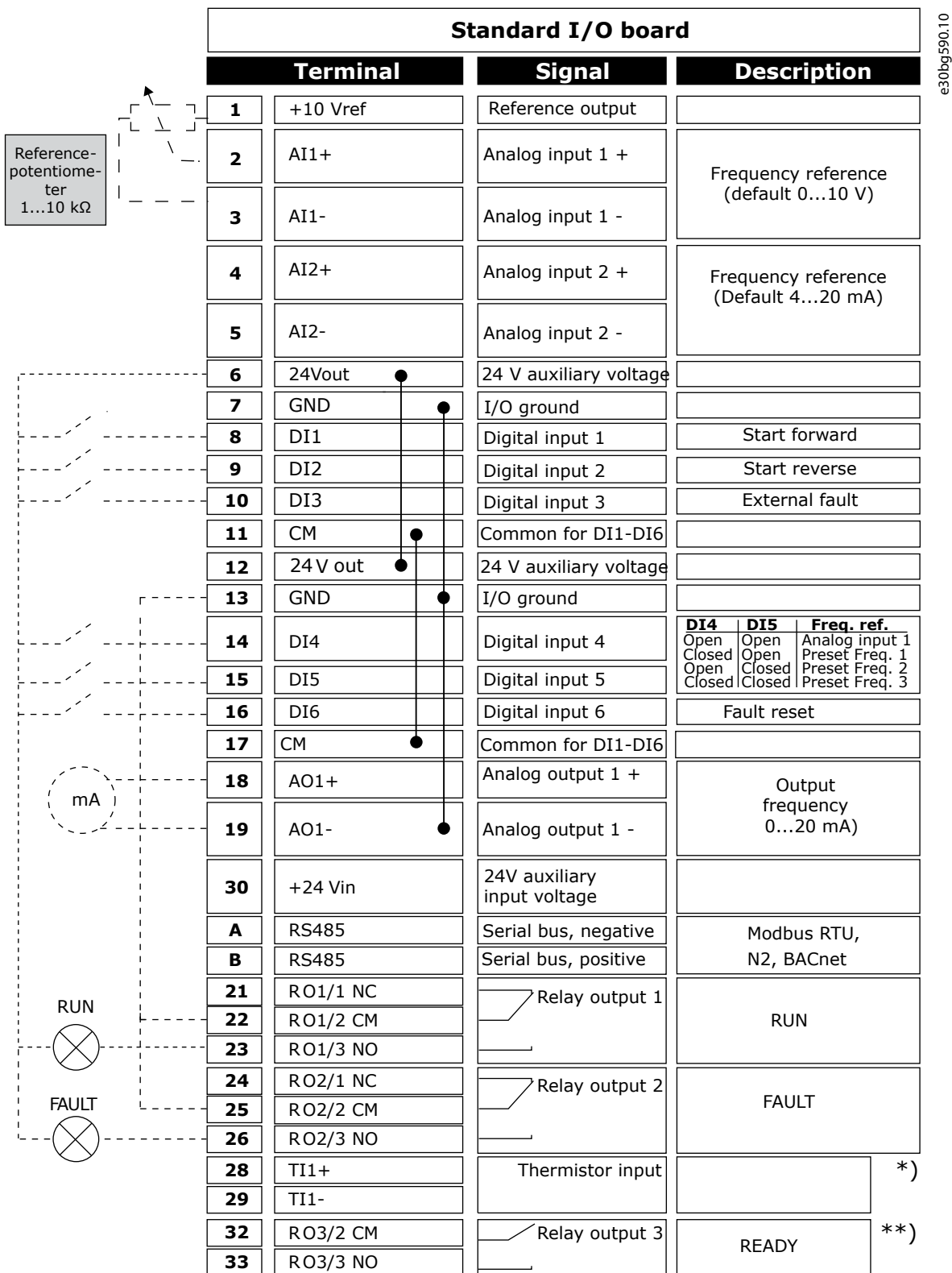

Illustration 6: The Default Control Connections of the Standard Application

*) Available only in VACON[®] 100 X. **) For the DIP switch configurations in VACON[®] 100 X, see the VACON[®] 100 X Installation manual.

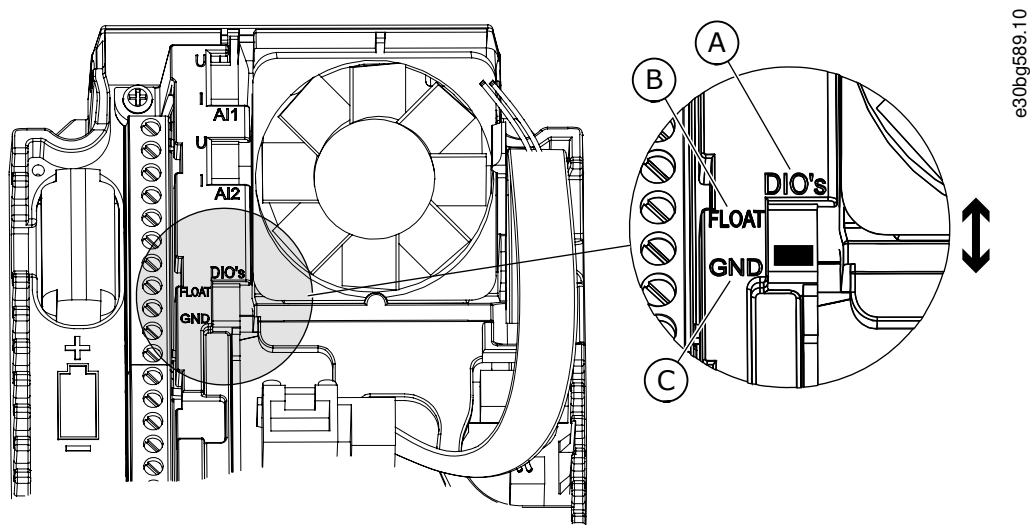

Illustration 7: The DIP Switch

A	Digital input DIP switch	C	Connected to GND (Default)
B	Floating		

See information on the Startup, Multi-pump, and Fire mode wizards in [4.2.1 Wizards in Menu 1.1](#).

Table 3: M1 Quick Setup

Index	Parameter	Min	Max	Unit	Default	ID	Description
1.2	Application	0	5		0	212	0 = Standard 1 = Local/Remote 2 = Multi-step Speed 3 = PID Control 4 = Multi-purpose 5 = Motor Potentiometer
1.3	Minimum Frequency Reference	0.00	P1.4	Hz	0.0	101	
1.4	Maximum Frequency Reference	P1.3	320.0	Hz	50.0/60.0	102	
1.5	Acceleration Time 1	0.1	300.0	s	5.0	103	
1.6	Deceleration Time 1	0.1	300.0	s	5.0	104	
1.7	Motor Current Limit	I _H *0.1	I _S	A	Varies	107	
1.8	Motor Type	0	2		0	650	0 = Induction Motor 1 = Permanent Magnet Motor 2 = Reluctance Motor
1.9	Motor Nominal Voltage	Varies	Varies	V	Varies	110	Find this value U _n on the nameplate of the motor. NOTE! Find out if the motor connection is Delta or Star.
1.10	Motor Nominal Frequency	8.0	320.0	Hz	50/60	111	Find this value f _n on the nameplate of the motor.

Index	Parameter	Min	Max	Unit	Default	ID	Description
1.11	Motor Nominal Speed	24	19200	RPM	Varies	112	Find this value n_n on the nameplate of the motor.
1.12	Motor Nominal Current	IH * 0.1	IH * 2	A	Varies	113	Find this value I_n on the nameplate of the motor.
1.13	Motor Cos Phi (Power Factor)	0.30	1.00		Varies	120	Find this value on the nameplate of the motor.
1.14	Energy Optimization	0	1		0	666	0 = Disabled 1 = Enabled
1.15	Identification	0	2		0	631	0 = No action 1 = At standstill 2 = With rotation
1.16	Start Function	0	1		0	505	0 = Ramping 1 = Flying Start
1.17	Stop Function	0	1		0	506	0 = Coasting 1 = Ramping
1.18	Automatic Reset	0	1		0	731	0 = Disabled 1 = Enabled
1.19	Response to External Fault	0	3		2	701	0 = No action 1 = Alarm 2 = Fault (Stop according to stop mode) 3 = Fault (Stop by coasting)
1.20	Response to AI Low Fault	0	5		0	700	0 = No action 1 = Alarm 2 = Alarm+preset fault frequency (P3.9.1.13) 3 = Alarm + previous frequency 4 = Fault (Stop according to stop mode) 5 = Fault (Stop by coasting)
1.21	Remote Control Place	0	1		0	172	0 = I/O control 1 = Fieldbus control
1.22	I/O Control Reference A Selection	1	20		6	117	1 = Preset Frequency 0 2 = Keypad reference 3 = Fieldbus 4 = AI1 5 = AI2 6 = AI1+AI2 7 = PID reference 8 = Motor potentiometer 9 = Joystick reference 10 = Jogging reference 11 = Block Out.1 12 = Block Out.2 13 = Block Out.3

Index	Parameter	Min	Max	Unit	Default	ID	Description
							14 = Block Out.4 15 = Block Out.5 16 = Block Out.6 17 = Block Out.7 18 = Block Out.8 19 = Block Out.9 20 = Block Out.10
1.23	Keypad Control Reference Selection	1	20		2	121	See P1.22.
1.24	Fieldbus Control Reference Selection	1	20		3	122	See P1.22.
1.25	AI1 Signal Range	0	1		0	379	0= 0..10 V/0...20 mA 1= 2...10 V/4...20 mA
1.26	AI2 Signal Range	0	1		1	390	0= 0..10 V/0...20 mA 1= 2...10 V/4...20 mA
1.27	RO1 Function	0	61		2	11001	See P3.5.3.2.1.
1.28	RO2 Function	0	56		3	11004	See P3.5.3.2.1.
1.29	RO3 Function	0	56		1	11007	See P3.5.3.2.1.
1.30	AO1 Function	0	31		2	10050	See P3.5.4.1.1.

Table 4: M1.31 Standard

Index	Parameter	Min	Max	Unit	Default	ID	Description
1.31.1	Preset Frequency 1	P1.3	P1.4	Hz	10.0	105	
1.31.2	Preset Frequency 2	P1.3	P1.4	Hz	15.0	106	
1.31.3	Preset Frequency 3	P1.3	P1.4	Hz	20.0	126	

3.3 Local/Remote Application

Use the Local/Remote application when, for example, it is necessary to switch between 2 different control places.

To change between the Local and the Remote control place, use DI6. When Remote control is active, the start/stop commands can be given from Fieldbus or from I/O terminal (DI1 and DI2). When Local control is active, give the start/stop commands from the control panel.

For each control place, the frequency reference can be selected from the control panel (keypad), Fieldbus, or I/O terminal (AI1 or AI2).

It is possible to configure all the drive outputs freely in all the applications. There is 1 analog output (Output Frequency) and 3 relay outputs (Run, Fault, Ready) available on the basic I/O board.

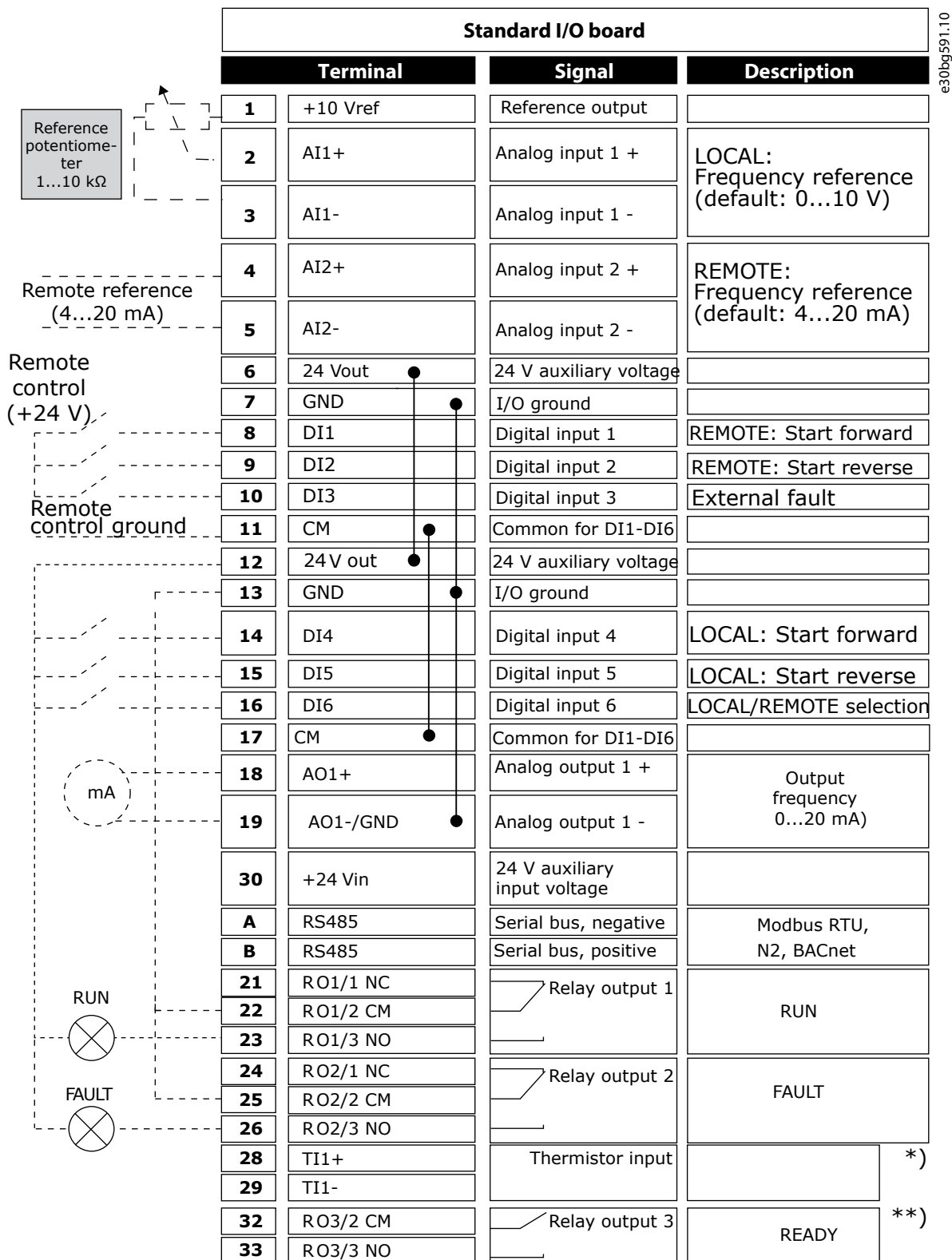

Illustration 8: The Default Control Connections of the Local/Remote Application

*) Available only in VACON[®] 100 X. **) For the DIP switch configurations in VACON[®] 100 X, see the VACON[®] 100 X Installation manual.

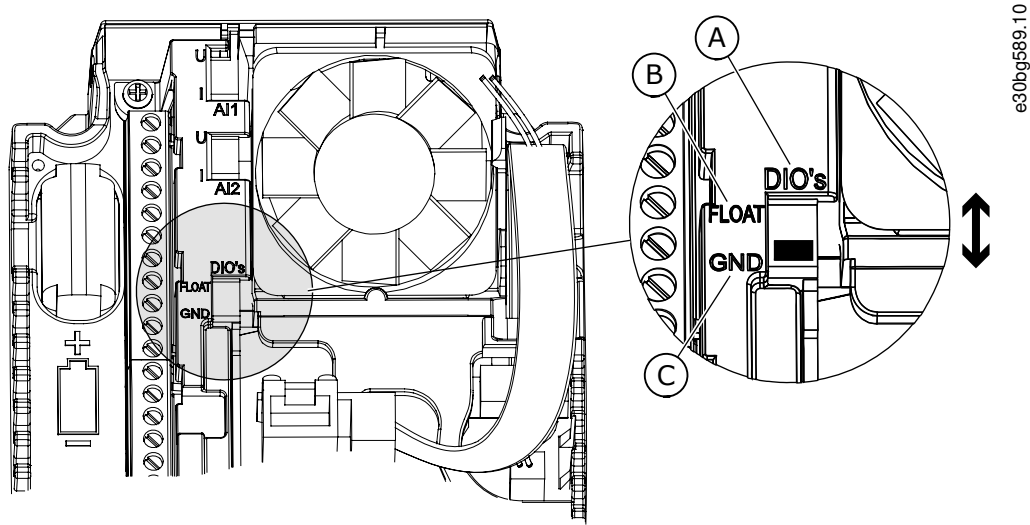

Illustration 9: The DIP Switch

A	Digital input DIP switch	C	Connected to GND (Default)
B	Floating		

See information on the Startup, Multi-pump, and Fire mode wizards in [4.2.1 Wizards in Menu 1.1](#).

Table 5: M1 Quick Setup

Index	Parameter	Min	Max	Unit	Default	ID	Description
1.2	Application	0	5		1	212	0 = Standard 1 = Local/Remote 2 = Multi-step Speed 3 = PID Control 4 = Multi-purpose 5 = Motor Potentiometer
1.3	Minimum Frequency Reference	0.00	P1.4	Hz	0.0	101	
1.4	Maximum Frequency Reference	P1.3	320.0	Hz	50.0/60.0	102	
1.5	Acceleration Time 1	0.1	300.0	s	5.0	103	
1.6	Deceleration Time 1	0.1	300.0	s	5.0	104	
1.7	Motor Current Limit	I _H *0.1	I _S	A	Varies	107	
1.8	Motor Type	0	2		0	650	0 = Induction Motor 1 = Permanent Magnet Motor 2 = Reluctance Motor
1.9	Motor Nominal Voltage	Varies	Varies	V	Varies	110	Find this value U _n on the nameplate of the motor. NOTE! Find out if the motor connection is Delta or Star.
1.10	Motor Nominal Frequency	8.0	320.0	Hz	50/60	111	Find this value f _n on the nameplate of the motor.

Index	Parameter	Min	Max	Unit	Default	ID	Description
1.11	Motor Nominal Speed	24	19200	RPM	Varies	112	Find this value n_n on the nameplate of the motor.
1.12	Motor Nominal Current	IH * 0.1	IH * 2	A	Varies	113	Find this value I_n on the nameplate of the motor.
1.13	Motor Cos Phi (Power Factor)	0.30	1.00		Varies	120	Find this value on the nameplate of the motor.
1.14	Energy Optimization	0	1		0	666	0 = Disabled 1 = Enabled
1.15	Identification	0	2		0	631	0 = No action 1 = At standstill 2 = With rotation
1.16	Start Function	0	1		0	505	0 = Ramping 1 = Flying Start
1.17	Stop Function	0	1		0	506	0 = Coasting 1 = Ramping
1.18	Automatic Reset	0	1		0	731	0 = Disabled 1 = Enabled
1.19	Response to External Fault	0	3		2	701	0 = No action 1 = Alarm 2 = Fault (Stop according to stop mode) 3 = Fault (Stop by coasting)
1.20	Response to AI Low Fault	0	5		0	700	0 = No action 1 = Alarm 2 = Alarm+preset fault frequency (P3.9.1.13) 3 = Alarm + previous frequency 4 = Fault (Stop according to stop mode) 5 = Fault (Stop by coasting)
1.21	Remote Control Place	0	1		0	172	0 = I/O control 1 = Fieldbus control
1.22	I/O Control Reference A Selection	1	20		5	117	1 = Preset Frequency 0 2 = Keypad reference 3 = Fieldbus 4 = AI1 5 = AI2 6 = AI1+AI2 7 = PID reference 8 = Motor potentiometer 9 = Joystick reference 10 = Jogging reference 11 = Block Out.1 12 = Block Out.2 13 = Block Out.3

Index	Parameter	Min	Max	Unit	Default	ID	Description
							14 = Block Out.4 15 = Block Out.5 16 = Block Out.6 17 = Block Out.7 18 = Block Out.8 19 = Block Out.9 20 = Block Out.10
1.23	Keypad Control Reference Selection	1	20		2	121	See P1.22.
1.24	Fieldbus Control Reference Selection	1	20		3	122	See P1.22.
1.25	AI1 Signal Range	0	1		0	379	0= 0...10 V/0...20 mA 1= 2...10 V/4...20 mA
1.26	AI2 Signal Range	0	1		1	390	0= 0...10 V/0...20 mA 1= 2...10 V/4...20 mA
1.27	RO1 Function	0	61		2	11001	See P3.5.3.2.1.
1.28	RO2 Function	0	56		3	11004	See P3.5.3.2.1.
1.29	RO3 Function	0	56		1	11007	See P3.5.3.2.1.
1.30	AO1 Function	0	31		2	10050	See P3.5.4.1.1.

Table 6: M1.32 Local/Remote

Index	Parameter	Min	Max	Unit	Default	ID	Description
1.32.1	I/O Control Reference B Selection	1	20		4	131	See P1.22.
1.32.2	I/O B Control Force				digIN SlotA.6	425	CLOSED = Force control place to I/O B
1.32.3	I/O B Reference Force				digIN SlotA.6	343	CLOSED = Used frequency reference is specified by I/O Reference B parameter (P1.32.1)
1.32.4	Control Signal 1 B				digIN SlotA.4	423	
1.32.5	Control Signal 2 B				digIN SlotA.5	424	
1.32.6	Keypad Control Force				digIN SlotA.1	410	
1.32.7	Fieldbus Control Force				digIN Slot0.1	411	
1.32.8	External Fault (Close)				digIN SlotA.3	405	OPEN = OK CLOSED = External fault
1.32.9	Fault Reset (Close)				digIN Slot0.1	414	Resets all active faults when CLOSED

3.4 Multi-step Speed Application

Use the Multi-step speed application with processes where more than 1 fixed frequency reference is necessary (for example test benches).

It is possible to use 1 + 7 frequency references: 1 basic reference (AI1 or AI2) and 7 preset references.

Make a selection of the preset frequency references with digital signals DI4, DI5, and DI6. If none of these inputs are active, the frequency reference is removed from the analog input (AI1 or AI2). Give the start/stop commands from the I/O terminal (DI1 and DI2).

It is possible to configure all the drive outputs freely in all the applications. There is 1 analog output (Output Frequency) and 3 relay outputs (Run, Fault, Ready) available on the basic I/O board.

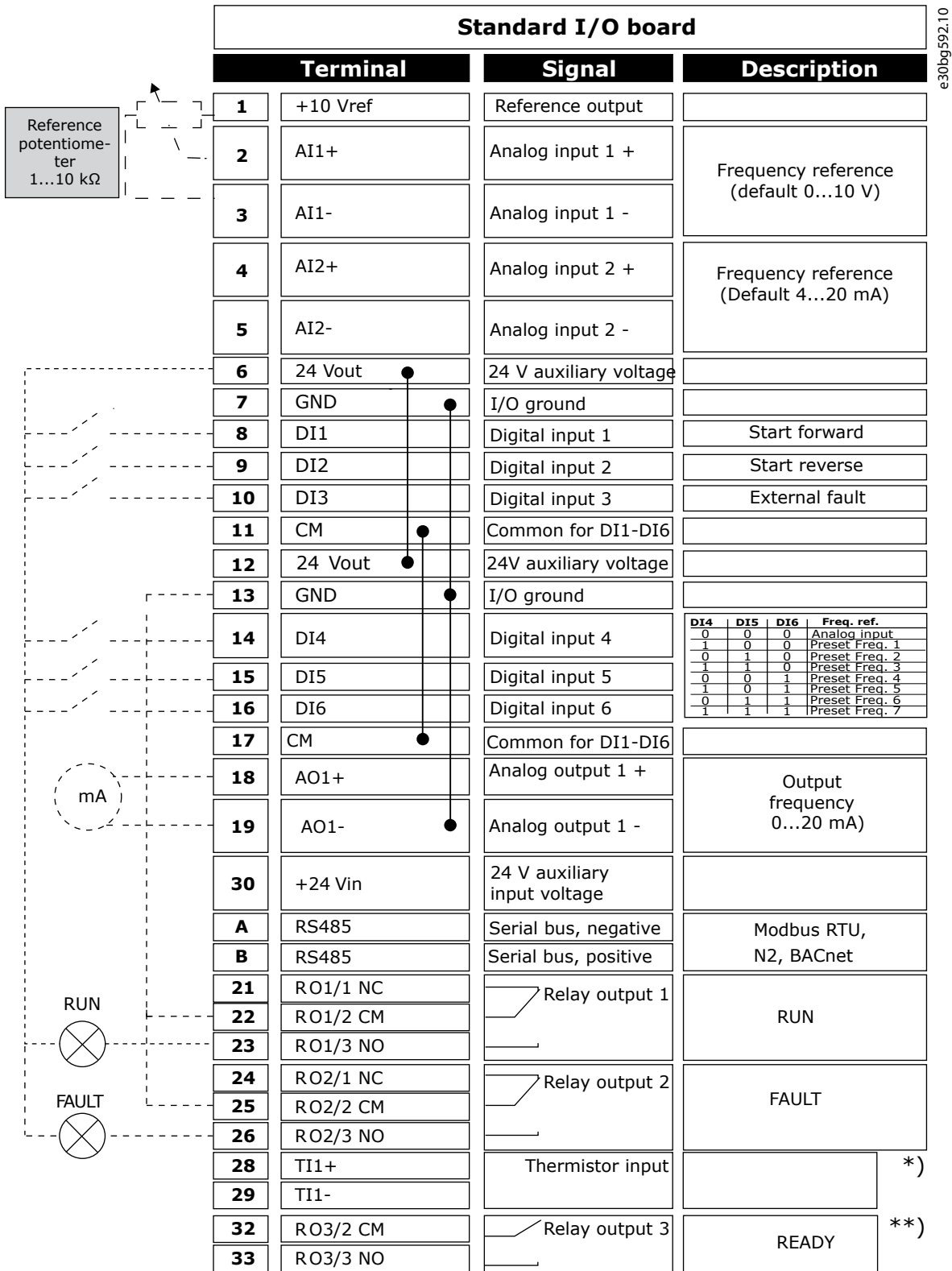

Illustration 10: The Default Control Connections of the Multi-step Speed Application

*) Available only in VACON[®] 100 X. **) For the DIP switch configurations in VACON[®] 100 X, see the VACON[®] 100 X Installation manual.

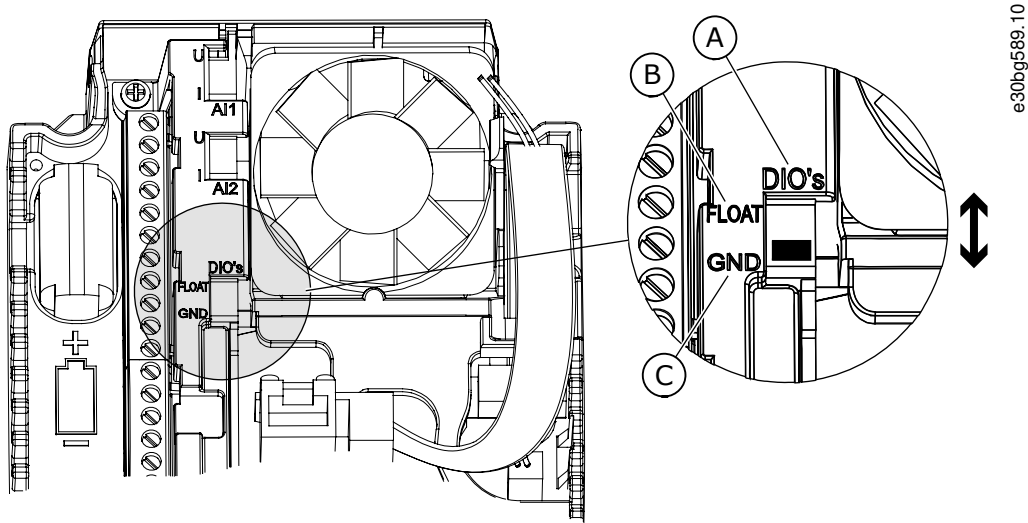

Illustration 11: The DIP Switch

A	Digital input DIP switch	C	Connected to GND (Default)
B	Floating		

See information on the Startup, Multi-pump, and Fire mode wizards in [4.2.1 Wizards in Menu 1.1](#).

Table 7: M1 Quick Setup

Index	Parameter	Min	Max	Unit	Default	ID	Description
1.2	Application	0	5		2	212	0 = Standard 1 = Local/Remote 2 = Multi-step Speed 3 = PID Control 4 = Multi-purpose 5 = Motor Potentiometer
1.3	Minimum Frequency Reference	0.00	P1.4	Hz	0.0	101	
1.4	Maximum Frequency Reference	P1.3	320.0	Hz	50.0/60.0	102	
1.5	Acceleration Time 1	0.1	300.0	s	5.0	103	
1.6	Deceleration Time 1	0.1	300.0	s	5.0	104	
1.7	Motor Current Limit	I _H *0.1	I _S	A	Varies	107	
1.8	Motor Type	0	2		0	650	0 = Induction Motor 1 = Permanent Magnet Motor 2 = Reluctance Motor
1.9	Motor Nominal Voltage	Varies	Varies	V	Varies	110	Find this value U _n on the nameplate of the motor. NOTE! Find out if the motor connection is Delta or Star.

Index	Parameter	Min	Max	Unit	Default	ID	Description
1.10	Motor Nominal Frequency	8.0	320.0	Hz	50/60	111	Find this value f_n on the nameplate of the motor.
1.11	Motor Nominal Speed	24	19200	RPM	Varies	112	Find this value n_n on the nameplate of the motor.
1.12	Motor Nominal Current	I _H * 0.1	I _H * 2	A	Varies	113	Find this value I_n on the nameplate of the motor.
1.13	Motor Cos Phi (Power Factor)	0.30	1.00		Varies	120	Find this value on the nameplate of the motor.
1.14	Energy Optimization	0	1		0	666	0 = Disabled 1 = Enabled
1.15	Identification	0	2		0	631	0 = No action 1 = At standstill 2 = With rotation
1.16	Start Function	0	1		0	505	0 = Ramping 1 = Flying Start
1.17	Stop Function	0	1		0	506	0 = Coasting 1 = Ramping
1.18	Automatic Reset	0	1		0	731	0 = Disabled 1 = Enabled
1.19	Response to External Fault	0	3		2	701	0 = No action 1 = Alarm 2 = Fault (Stop according to stop mode) 3 = Fault (Stop by coasting)
1.20	Response to AI Low Fault	0	5		0	700	0 = No action 1 = Alarm 2 = Alarm+preset fault frequency (P3.9.1.13) 3 = Alarm + previous frequency 4 = Fault (Stop according to stop mode) 5 = Fault (Stop by coasting)
1.21	Remote Control Place	0	1		0	172	0 = I/O control 1 = Fieldbus control
1.22	I/O Control Reference A Selection	1	20		6	117	1 = Preset Frequency 0 2 = Keypad reference 3 = Fieldbus 4 = AI1 5 = AI2 6 = AI1+AI2 7 = PID reference 8 = Motor potentiometer 9 = Joystick reference 10 = Jogging reference

Index	Parameter	Min	Max	Unit	Default	ID	Description
							11 = Block Out.1 12 = Block Out.2 13 = Block Out.3 14 = Block Out.4 15 = Block Out.5 16 = Block Out.6 17 = Block Out.7 18 = Block Out.8 19 = Block Out.9 20 = Block Out.10
1.23	Keypad Control Reference Selection	1	20		2	121	See P1.22.
1.24	Fieldbus Control Reference Selection	1	20		3	122	See P1.22.
1.25	AI1 Signal Range	0	1		0	379	0= 0...10 V/0...20 mA 1= 2...10 V/4...20 mA
1.26	AI2 Signal Range	0	1		1	390	0= 0...10 V/0...20 mA 1= 2...10 V/4...20 mA
1.27	RO1 Function	0	61		2	11001	See P3.5.3.2.1.
1.28	RO2 Function	0	56		3	11004	See P3.5.3.2.1.
1.29	RO3 Function	0	56		1	11007	See P3.5.3.2.1.
1.30	AO1 Function	0	31		2	10050	See P3.5.4.1.1.

Table 8: M1.33 Multi-step Speed

Index	Parameter	Min	Max	Unit	Default	ID	Description
1.33.1	Preset Frequency 1	P1.3	P1.4	Hz	10.0	105	
1.33.2	Preset Frequency 2	P1.3	P1.4	Hz	15.0	106	
1.33.3	Preset Frequency 3	P1.3	P1.4	Hz	20.0	126	
1.33.4	Preset Frequency 4	P1.3	P1.4	Hz	25.0	127	
1.33.5	Preset Frequency 5	P1.3	P1.4	Hz	30.0	128	
1.33.6	Preset Frequency 6	P1.3	P1.4	Hz	40.0	129	
1.33.7	Preset Frequency 7	P1.3	P1.4	Hz	50.0	130	
1.33.8	Preset Frequency Mode	0	1		0	182	0 = Binary Coded 1 = Number of inputs. Preset frequency is selected according to how many of preset speed digital inputs are active.
1.33.9	External Fault (Close)				DigIN SlotA.3	405	CLOSED = OK

Index	Parameter	Min	Max	Unit	Default	ID	Description
							OPEN = External fault
1.33.10	Fault Reset (Close)				DigIN Slot0.1	414	Resets all active faults when CLOSED

3.5 PID Control Application

Use the PID control application with processes where the process variable (for example pressure) is controlled through control of the speed of the motor.

In this application, the internal PID controller of the drive is configured for 1 setpoint and 1 feedback signal.

It is possible to use 2 control places. Make the selection of the control place A or B with DI6. When control place A is active, the start/stop commands are given by DI1, and the PID controller gives the frequency reference. When control place B is active, start/stop commands are given by DI4, and AI1 gives the frequency reference.

It is possible to configure all the drive outputs freely in all the applications. There are 1 analog output (Output Frequency) and 3 relay outputs (Run, Fault, Ready) available on the basic I/O board.

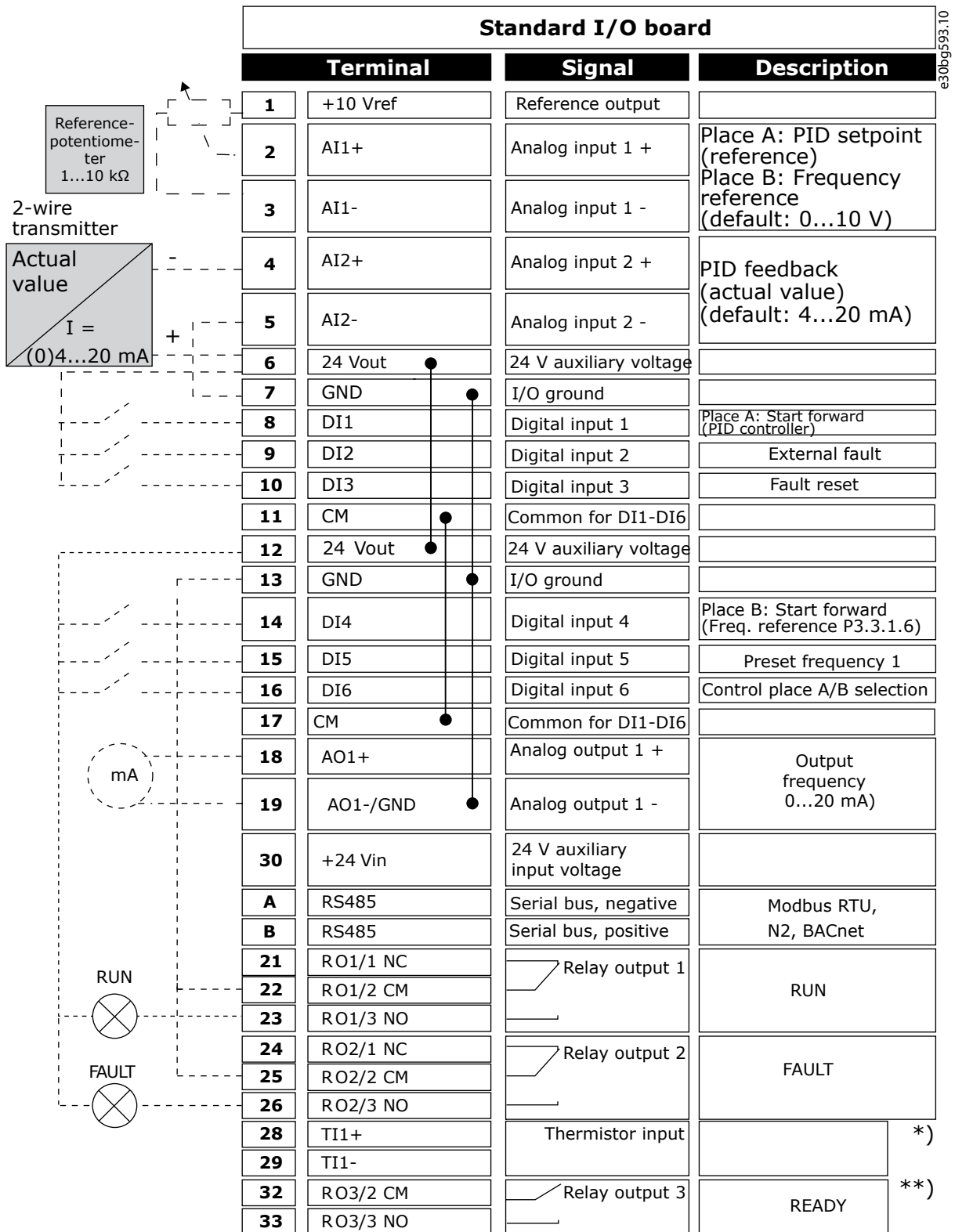

Illustration 12: The Default Control Connections of the PID Control Application

*) Available only in VACON[®] 100 X. **) For the DIP switch configurations in VACON[®] 100 X, see the VACON[®] 100 X Installation manual.

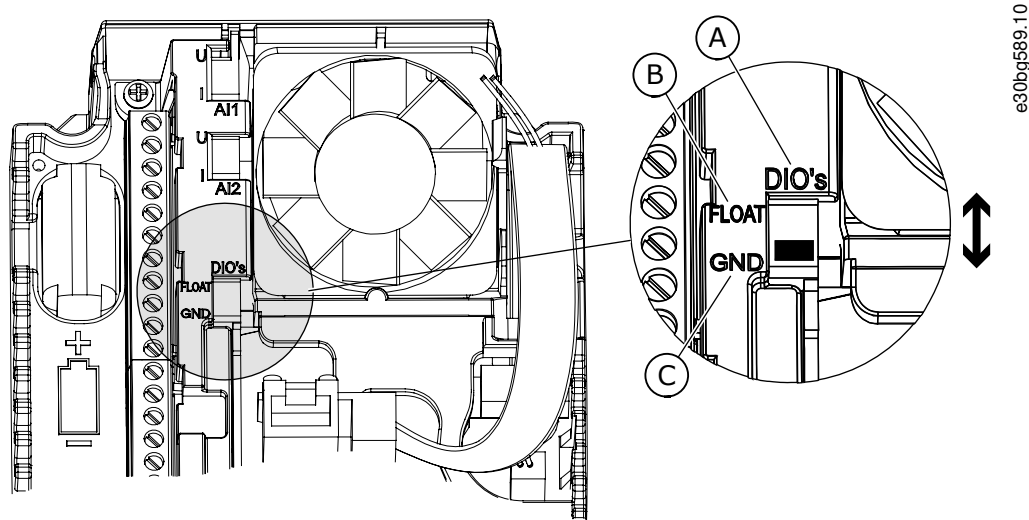

Illustration 13: The DIP Switch

A	Digital input DIP switch	C	Connected to GND (Default)
B	Floating		

See information on the Startup, Multi-pump, and Fire mode wizards in [4.2.1 Wizards in Menu 1.1](#).

Table 9: M1 Quick Setup

Index	Parameter	Min	Max	Unit	Default	ID	Description
1.2	Application	0	5		3	212	0 = Standard 1 = Local/Remote 2 = Multi-step Speed 3 = PID Control 4 = Multi-purpose 5 = Motor Potentiometer
1.3	Minimum Frequency Reference	0.00	P1.4	Hz	0.0	101	
1.4	Maximum Frequency Reference	P1.3	320.0	Hz	50.0/60.0	102	
1.5	Acceleration Time 1	0.1	300.0	s	5.0	103	
1.6	Deceleration Time 1	0.1	300.0	s	5.0	104	
1.7	Motor Current Limit	I _H *0.1	I _S	A	Varies	107	
1.8	Motor Type	0	2		0	650	0 = Induction Motor 1 = Permanent Magnet Motor 2 = Reluctance Motor
1.9	Motor Nominal Voltage	Varies	Varies	V	Varies	110	Find this value U _n on the nameplate of the motor. NOTE! Find out if the motor connection is Delta or Star.
1.10	Motor Nominal Frequency	8.0	320.0	Hz	50/60	111	Find this value f _n on the nameplate of the motor.

Index	Parameter	Min	Max	Unit	Default	ID	Description
1.11	Motor Nominal Speed	24	19200	RPM	Varies	112	Find this value n_n on the nameplate of the motor.
1.12	Motor Nominal Current	IH * 0.1	IH * 2	A	Varies	113	Find this value I_n on the nameplate of the motor.
1.13	Motor Cos Phi (Power Factor)	0.30	1.00		Varies	120	Find this value on the nameplate of the motor.
1.14	Energy Optimization	0	1		0	666	0 = Disabled 1 = Enabled
1.15	Identification	0	2		0	631	0 = No action 1 = At standstill 2 = With rotation
1.16	Start Function	0	1		0	505	0 = Ramping 1 = Flying Start
1.17	Stop Function	0	1		0	506	0 = Coasting 1 = Ramping
1.18	Automatic Reset	0	1		0	731	0 = Disabled 1 = Enabled
1.19	Response to External Fault	0	3		2	701	0 = No action 1 = Alarm 2 = Fault (Stop according to stop mode) 3 = Fault (Stop by coasting)
1.20	Response to AI Low Fault	0	5		0	700	0 = No action 1 = Alarm 2 = Alarm+preset fault frequency (P3.9.1.13) 3 = Alarm + previous frequency 4 = Fault (Stop according to stop mode) 5 = Fault (Stop by coasting)
1.21	Remote Control Place	0	1		0	172	0 = I/O control 1 = Fieldbus control
1.22	I/O Control Reference A Selection	1	20		7	117	1 = Preset Frequency 0 2 = Keypad reference 3 = Fieldbus 4 = AI1 5 = AI2 6 = AI1+AI2 7 = PID reference 8 = Motor potentiometer 9 = Joystick reference 10 = Jogging reference 11 = Block Out.1 12 = Block Out.2 13 = Block Out.3

Index	Parameter	Min	Max	Unit	Default	ID	Description
							14 = Block Out.4 15 = Block Out.5 16 = Block Out.6 17 = Block Out.7 18 = Block Out.8 19 = Block Out.9 20 = Block Out.10
1.23	Keypad Control Reference Selection	1	20		2	121	See P1.22.
1.24	Fieldbus Control Reference Selection	1	20		3	122	See P1.22.
1.25	AI1 Signal Range	0	1		0	379	0= 0...10 V/0...20 mA 1= 2...10 V/4...20 mA
1.26	AI2 Signal Range	0	1		1	390	0= 0...10 V/0...20 mA 1= 2...10 V/4...20 mA
1.27	RO1 Function	0	61		2	11001	See P3.5.3.2.1.
1.28	RO2 Function	0	56		3	11004	See P3.5.3.2.1.
1.29	RO3 Function	0	56		1	11007	See P3.5.3.2.1.
1.30	AO1 Function	0	31		2	10050	See P3.5.4.1.1.

Table 10: M1.34 PID control

Index	Parameter	Min	Max	Unit	Default	ID	Description
1.34.1	PID Gain	0.00	100.00	%	100.00	118	
1.34.2	PID Integration Time	0.00	600.00	s	1.00	119	
1.34.3	PID Derivation Time	0.00	100.00	s	0.00	132	
1.34.4	Feedback 1 Source Selection	0	30		2	334	See P3.13.3.3.
1.34.5	Setpoint 1 Source Selection	0	32		1	332	See P3.13.2.6.
1.34.6	Keypad Setpoint 1	Varies	Varies	Varies	0	167	
1.34.7	Sleep Frequency Limit 1	0.00	320.0	Hz	0.0	1016	
1.34.8	Sleep Delay 1	0	3000	s	0	1017	
1.34.9	Wake-up Level 1	Varies	Varies	Varies	Varies	1018	
1.34.10	Preset Frequency 1	P1.3	P1.4	Hz	10.0	105	

3.6 Multi-purpose Application

The Multi-purpose application can be used for different processes (for example conveyors) where a wide range of motor control functions is necessary.

It is possible to control the drive from the keypad, Fieldbus, or I/O terminal. When using I/O terminal control, the start/stop commands are given through DI1 and DI2, and the frequency reference from AI1 or AI2.

There are 2 acceleration/deceleration ramps available. The selection between Ramp1 and Ramp2 is made by DI6.

It is possible to configure all the drive outputs freely in all the applications. There is 1 analog output (Output Frequency) and 3 relay outputs (Run, Fault, Ready) available on the basic I/O board.

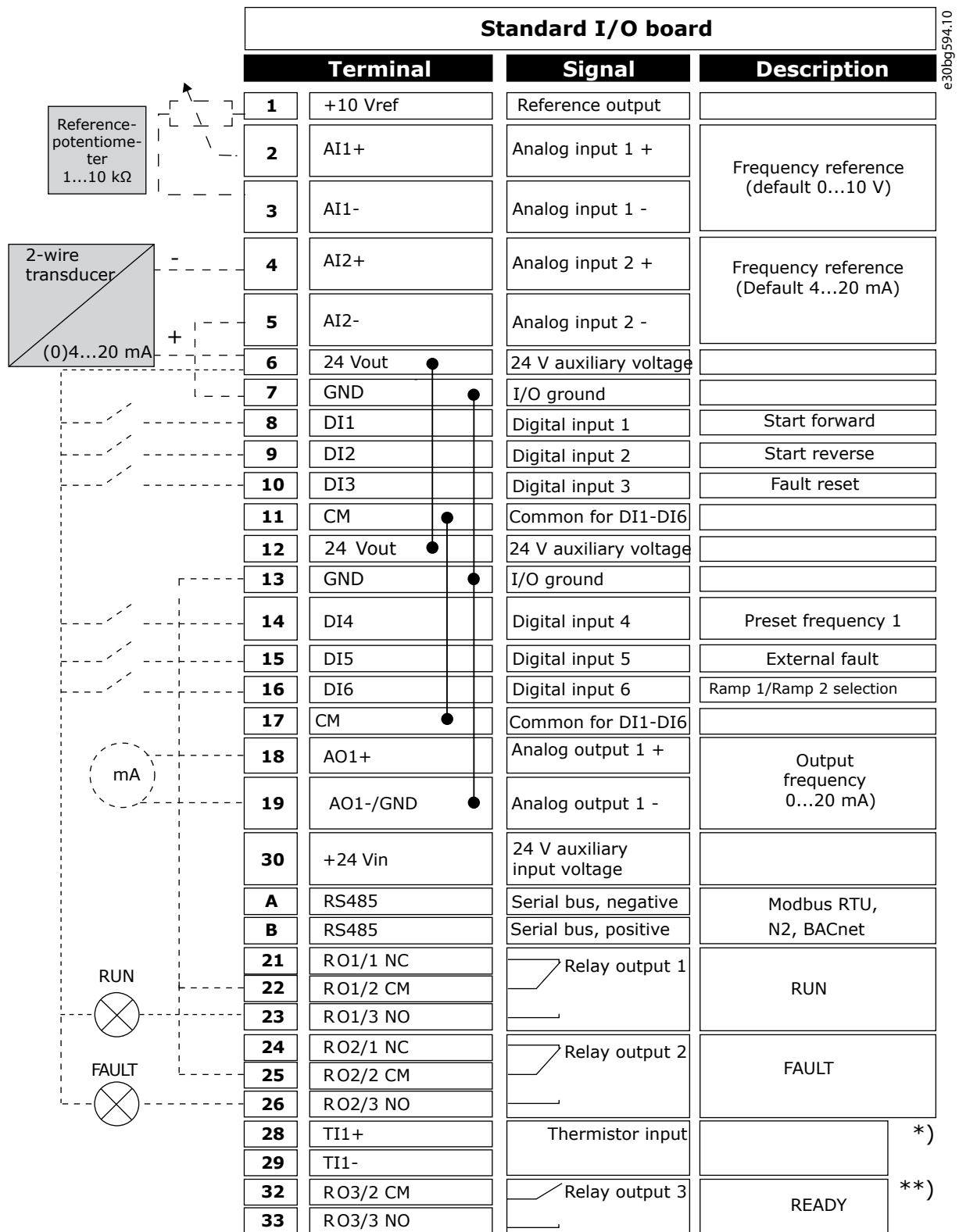

Illustration 14: The Default Control Connections of the Multi-purpose Application

*) Available only in VACON[®] 100 X. **) For the DIP switch configurations in VACON[®] 100 X, see the VACON[®] 100 X Installation manual.

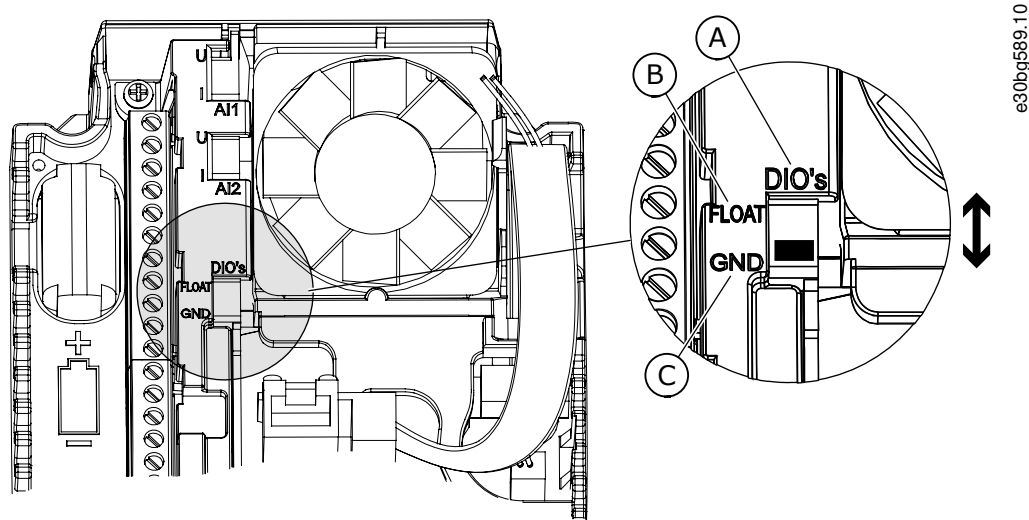

Illustration 15: The DIP Switch

A	Digital input DIP switch	C	Connected to GND (Default)
B	Floating		

See information on the Startup, Multi-pump, and Fire mode wizards in [4.2.1 Wizards in Menu 1.1](#).

Table 11: M1 Quick Setup

Index	Parameter	Min	Max	Unit	Default	ID	Description
1.2	Application	0	5		4	212	0 = Standard 1 = Local/Remote 2 = Multi-step Speed 3 = PID Control 4 = Multi-purpose 5 = Motor Potentiometer
1.3	Minimum Frequency Reference	0.00	P1.4	Hz	0.0	101	
1.4	Maximum Frequency Reference	P1.3	320.0	Hz	50.0/60.0	102	
1.5	Acceleration Time 1	0.1	300.0	s	5.0	103	
1.6	Deceleration Time 1	0.1	300.0	s	5.0	104	
1.7	Motor Current Limit	I _H *0.1	I _S	A	Varies	107	
1.8	Motor Type	0	2		0	650	0 = Induction Motor 1 = Permanent Magnet Motor 2 = Reluctance Motor
1.9	Motor Nominal Voltage	Varies	Varies	V	Varies	110	Find this value U _n on the nameplate of the motor. NOTE! Find out if the motor connection is Delta or Star.
1.10	Motor Nominal Frequency	8.0	320.0	Hz	50/60	111	Find this value f _n on the nameplate of the motor.

Index	Parameter	Min	Max	Unit	Default	ID	Description
1.11	Motor Nominal Speed	24	19200	Rpm	Varies	112	Find this value n_n on the nameplate of the motor.
1.12	Motor Nominal Current	IH * 0.1	IH * 2	A	Varies	113	Find this value I_n on the nameplate of the motor.
1.13	Motor Cos Phi (Power Factor)	0.30	1.00		Varies	120	Find this value on the nameplate of the motor.
1.14	Energy Optimization	0	1		0	666	0 = Disabled 1 = Enabled
1.15	Identification	0	2		0	631	0 = No action 1 = At standstill 2 = With rotation
1.16	Start Function	0	1		0	505	0 = Ramping 1 = Flying Start
1.17	Stop Function	0	1		0	506	0 = Coasting 1 = Ramping
1.18	Automatic Reset	0	1		0	731	0 = Disabled 1 = Enabled
1.19	Response to External Fault	0	3		2	701	0 = No action 1 = Alarm 2 = Fault (Stop according to stop mode) 3 = Fault (Stop by coasting)
1.20	Response to AI Low Fault	0	5		0	700	0 = No action 1 = Alarm 2 = Alarm+preset fault frequency (P3.9.1.13) 3 = Alarm + previous frequency 4 = Fault (Stop according to stop mode) 5 = Fault (Stop by coasting)
1.21	Remote Control Place	0	1		0	172	0 = I/O control 1 = Fieldbus control
1.22	I/O Control Reference A Selection	1	20		6	117	1 = Preset Frequency 0 2 = Keypad reference 3 = Fieldbus 4 = AI1 5 = AI2 6 = AI1+AI2 7 = PID reference 8 = Motor potentiometer 9 = Joystick reference 10 = Jogging reference 11 = Block Out.1 12 = Block Out.2 13 = Block Out.3

Index	Parameter	Min	Max	Unit	Default	ID	Description
							14 = Block Out.4 15 = Block Out.5 16 = Block Out.6 17 = Block Out.7 18 = Block Out.8 19 = Block Out.9 20 = Block Out.10
1.23	Keypad Control Reference Selection	1	20		2	121	See P1.22.
1.24	Fieldbus Control Reference Selection	1	20		3	122	See P1.22.
1.25	AI1 Signal Range	0	1		0	379	0= 0...10 V/0...20 mA 1= 2...10 V/4...20 mA
1.26	AI2 Signal Range	0	1		1	390	0= 0...10 V/0...20 mA 1= 2...10 V/4...20 mA
1.27	RO1 Function	0	61		2	11001	See P3.5.3.2.1.
1.28	RO2 Function	0	56		3	11004	See P3.5.3.2.1.
1.29	RO3 Function	0	56		1	11007	See P3.5.3.2.1.
1.30	AO1 Function	0	31		2	10050	See P3.5.4.1.1.

Table 12: M1.35 Multi-purpose

Index	Parameter	Min	Max	Unit	Default	ID	Description
1.35.1	Control Mode	0	2		0	600	0 = U/f Freq Control open loop 1 = Speed control open loop 2 = Torque Control open loop
1.35.2	Auto Torque Boost	0	1		0	109	0 = Disabled 1 = Enabled
1.35.3	Acceleration Time 2	0.1	300.0	s	10.0	502	
1.35.4	Deceleration Time 2	0.1	300.0	s	10.0	503	
1.35.5	Preset Frequency 1	P1.3	P1.4	Hz	5.0	105	
1.35.6	U/f Ratio Select	0	2		0	108	0 = Linear 1 = Squared 2 = Programmable
1.35.7	Field Weakening Point Frequency	8.00	P1.4	Hz	Varies	602	
1.35.8	Voltage at Field Weakening Point	10.00	200.00	%	100.00	603	
1.35.9	U/f Midpoint Frequency	0.0	P1.35.7	Hz	Varies	604	
1.35.10	U/f Midpoint Voltage	0.0	100.00	%	100.0	605	
1.35.11	Zero Frequency Voltage	0.00	40.00	%	Varies	606	

Index	Parameter	Min	Max	Unit	Default	ID	Description
1.35.12	Start Magnetizing Current	0.00	Varies	A	Varies	517	
1.35.13	Start Magnetizing Time	0.00	600.00	s	0.00	516	
1.35.14	DC Brake Current	Varies	Varies	A	Varies	507	0 = Disabled
1.35.15	DC Braking Time at stop	0.00	600.00	s	0.00	508	
1.35.16	Frequency to Start DC Braking at Ramp Stop	0.10	50.00	%	1.5	515	
1.35.17	Load Drooping	0.00	50.00	%	0.00	620	
1.35.18	Load Drooping Time	0.00	2.00	s	0.00	656	
1.35.19	Load Drooping Mode	0	1		0	1534	0 = Normal; Load drooping factor is constant through the whole frequency range 1 = Linear removal; Load drooping is removed linearly from nominal frequency to zero frequency

3.7 Motor Potentiometer Application

Use the Motor potentiometer application for the processes where the frequency reference of the motor is controlled (that is, increased and decreased) through digital inputs.

In this application, the I/O terminal is set to the default control place. The start/stop commands are given with DI1 and DI2. The frequency reference of the motor is increased with DI5 and decreased with DI6.

It is possible to configure all the drive outputs freely in all the applications. There is 1 analog output (Output Frequency) and 3 relay outputs (Run, Fault, Ready) available on the basic I/O board.

Standard I/O board			
Terminal	Signal	Description	
1	+10V ref	Reference output	
2	AI1+	Analog input 1 +	Not used
3	AI1-	Analog input 1 -	
4	AI2+	Analog input 2 +	Not used
5	AI2-	Analog input 2 -	
6	24 Vout	24 V auxiliary voltage	
7	GND	I/O ground	
8	DI1	Digital input 1	Start forward
9	DI2	Digital input 2	Start reverse
10	DI3	Digital input 3	External fault
11	CM	Common for DI1-DI6	
12	24 Vout	24 V auxiliary voltage	
13	GND	I/O ground	
14	DI4	Digital input 4	Preset frequency 1
15	DI5	Digital input 5	Frequency reference UP
16	DI6	Digital input 6	Frequency reference DOWN
17	CM	Common for DI1-DI6	
18	AO1+	Analogue output 1 +	Output frequency 0...20mA)
19	AO1-/GND	Analogue output 1 -	
30	+24 Vin	24 V auxiliary input voltage	
A	RS485	Serial bus, negative	Modbus, RTU, BACnet, N2
B	RS485	Serial bus, positive	
21	RO1/1 NC	Relay output 1	RUN
22	RO1/2 CM		
23	RO1/3 NO		
24	RO2/1 NC	Relay output 2	FAULT
25	RO2/2 CM		
26	RO2/3 NO		
28	TI1+	Thermistor input	*)
29	TI1-		
32	RO3/2 CM	Relay output 3	**)
33	RO3/3 NO		

e30bg595.10

Illustration 16: The Default Control Connections of the Motor Potentiometer Application

*) Available only in VACON[®] 100 X. **) For the DIP switch configurations in VACON[®] 100 X, see the VACON[®] 100 X Installation manual.

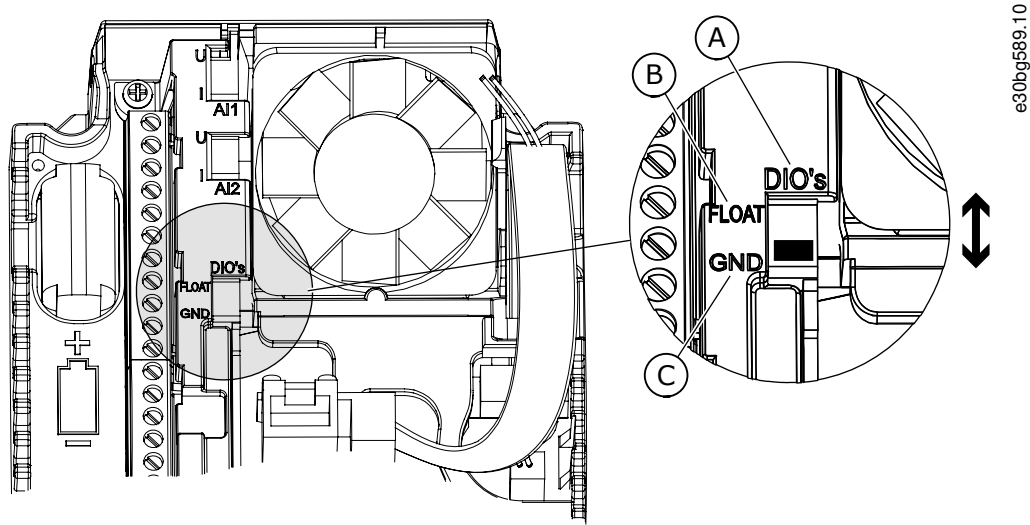

Illustration 17: The DIP Switch

A	Digital input DIP switch	C	Connected to GND (Default)
B	Floating		

See information on the Startup, Multi-pump, and Fire mode wizards in [4.2.1 Wizards in Menu 1.1](#).

Table 13: M1 Quick Setup

Index	Parameter	Min	Max	Unit	Default	ID	Description
1.2	Application	0	5		5	212	0 = Standard 1 = Local/Remote 2 = Multi-step Speed 3 = PID Control 4 = Multi-purpose 5 = Motor Potentiometer
1.3	Minimum Frequency Reference	0.00	P1.4	Hz	0.0	101	
1.4	Maximum Frequency Reference	P1.3	320.0	Hz	50.0/60.0	102	
1.5	Acceleration Time 1	0.1	300.0	s	5.0	103	
1.6	Deceleration Time 1	0.1	300.0	s	5.0	104	
1.7	Motor Current Limit	I _H *0.1	I _S	A	Varies	107	
1.8	Motor Type	0	2		0	650	0 = Induction Motor 1 = Permanent Magnet Motor 2 = Reluctance Motor
1.9	Motor Nominal Voltage	Varies	Varies	V	Varies	110	Find this value U _n on the nameplate of the motor. NOTE! Find out if the motor connection is Delta or Star.
1.10	Motor Nominal Frequency	8.0	320.0	Hz	50/60	111	Find this value f _n on the nameplate of the motor.

Index	Parameter	Min	Max	Unit	Default	ID	Description
1.11	Motor Nominal Speed	24	19200	RPM	Varies	112	Find this value n_n on the nameplate of the motor.
1.12	Motor Nominal Current	IH * 0.1	IH * 2	A	Varies	113	Find this value I_n on the nameplate of the motor.
1.13	Motor Cos Phi (Power Factor)	0.30	1.00		Varies	120	Find this value on the nameplate of the motor.
1.14	Energy Optimization	0	1		0	666	0 = Disabled 1 = Enabled
1.15	Identification	0	2		0	631	0 = No action 1 = At standstill 2 = With rotation
1.16	Start Function	0	1		0	505	0 = Ramping 1 = Flying Start
1.17	Stop Function	0	1		0	506	0 = Coasting 1 = Ramping
1.18	Automatic Reset	0	1		0	731	0 = Disabled 1 = Enabled
1.19	Response to External Fault	0	3		2	701	0 = No action 1 = Alarm 2 = Fault (Stop according to stop mode) 3 = Fault (Stop by coasting)
1.20	Response to AI Low Fault	0	5		0	700	0 = No action 1 = Alarm 2 = Alarm+preset fault frequency (P3.9.1.13) 3 = Alarm + previous frequency 4 = Fault (Stop according to stop mode) 5 = Fault (Stop by coasting)
1.21	Remote Control Place	0	1		0	172	0 = I/O control 1 = Fieldbus control
1.22	I/O Control Reference A Selection	1	20		8	117	1 = Preset Frequency 0 2 = Keypad reference 3 = Fieldbus 4 = AI1 5 = AI2 6 = AI1+AI2 7 = PID reference 8 = Motor potentiometer 9 = Joystick reference 10 = Jogging reference 11 = Block Out.1 12 = Block Out.2 13 = Block Out.3

Index	Parameter	Min	Max	Unit	Default	ID	Description
							14 = Block Out.4 15 = Block Out.5 16 = Block Out.6 17 = Block Out.7 18 = Block Out.8 19 = Block Out.9 20 = Block Out.10
1.23	Keypad Control Reference Selection	1	20		2	121	See P1.22.
1.24	Fieldbus Control Reference Selection	1	20		3	122	See P1.22.
1.25	AI1 Signal Range	0	1		0	379	0= 0...10 V/0...20 mA 1= 2...10 V/4...20 mA
1.26	AI2 Signal Range	0	1		1	390	0= 0...10 V/0...20 mA 1= 2...10 V/4...20 mA
1.27	RO1 Function	0	61		2	11001	See P3.5.3.2.1.
1.28	RO2 Function	0	56		3	11004	See P3.5.3.2.1.
1.29	RO3 Function	0	56		1	11007	See P3.5.3.2.1.
1.30	AO1 Function	0	31		2	10050	See P3.5.4.1.1.

Table 14: M1.36 Motor Potentiometer

Index	Parameter	Min	Max	Unit	Default	ID	Description
1.36.1	Motor Potentiometer Ramp Time	0.1	500.0	Hz/s	10.0	331	
1.36.2	Motor Potentiometer Reset	0	2		1	367	0 = No reset 1 = Reset if stopped 2 = Reset if powered down
1.36.3	Preset Frequency 1	P1.3	P1.4	Hz	10.0	105	

4 Wizards

4.1 Application Wizards

4.1.1 Standard Application Wizard

The application wizard helps to set the basic parameters that are related to the application.

To start the Standard application wizard, set the value Standard to parameter P1.2 Application (ID 212) in the keypad.

If the application wizard is started from the Start-up wizard, the wizard goes directly to step 11.

See the range of values of the parameters in [6.1 Group 3.1: Motor Settings](#), [6.3 Group 3.3: References](#), [6.4 Group 3.4: Ramps and Brakes Setup](#).

Procedure

1. Set a value for P3.1.2.2 Motor Type (so that it agrees with the nameplate of the motor).

➔ If Motor Type is set to Induction Motor, also step 6 is shown. If the selection is PM Motor, the value of parameter P3.1.1.5 Motor Cos Phi is set to 1.00, and the wizard skips step 6.

2. Set a value for P3.1.1.1 Motor Nominal Voltage (so that it agrees with the nameplate of the motor).
3. Set a value for P3.1.1.2 Motor Nominal Frequency (so that it agrees with the nameplate of the motor).
4. Set a value for P3.1.1.3 Motor Nominal Speed (so that it agrees with the nameplate of the motor).
5. Set a value for P3.1.1.4 Motor Nominal Current (so that it agrees with the nameplate of the motor).
6. Set a value for P3.1.1.5 Motor Cos Phi (so that it agrees with the nameplate of the motor).
7. Set a value for P3.3.1.1 Minimum Frequency Reference.
8. Set a value for P3.3.1.2 Maximum Frequency Reference.
9. Set a value for P3.4.1.2 Acceleration Time 1.
10. Set a value for P3.4.1.3 Deceleration Time 1.
11. Select the a control place (where to give the start and stop commands, and the frequency reference of the drive).

➔ The Standard application wizard is completed.

4.1.2 Local/Remote Application Wizard

The application wizard helps to set the basic parameters that are related to the application.

To start the Local/Remote application wizard, set the value Local/Remote to parameter P1.2 Application (ID 212) in the keypad.

If the application wizard is started from the Start-up wizard, the wizard goes directly to step 11.

See the range of values of the parameters in [6.1 Group 3.1: Motor Settings](#), [6.3 Group 3.3: References](#), [6.4 Group 3.4: Ramps and Brakes Setup](#).

Procedure

1. Set a value for P3.1.2.2 Motor Type (so that it agrees with the nameplate of the motor).

➔ If Motor Type is set to Induction Motor, also step 6 is shown. If the selection is PM Motor, the value of parameter P3.1.1.5 Motor Cos Phi is set to 1.00, and the wizard skips step 6.

2. Set a value for P3.1.1.1 Motor Nominal Voltage (so that it agrees with the nameplate of the motor).
3. Set a value for P3.1.1.2 Motor Nominal Frequency (so that it agrees with the nameplate of the motor).
4. Set a value for P3.1.1.3 Motor Nominal Speed (so that it agrees with the nameplate of the motor).
5. Set a value for P3.1.1.4 Motor Nominal Current (so that it agrees with the nameplate of the motor).
6. Set a value for P3.1.1.5 Motor Cos Phi (so that it agrees with the nameplate of the motor).
7. Set a value for P3.3.1.1 Minimum Frequency Reference.
8. Set a value for P3.3.1.2 Maximum Frequency Reference.
9. Set a value for P3.4.1.2 Acceleration Time 1.
10. Set a value for P3.4.1.3 Deceleration Time 1.
11. Select the Remote control place (where to give the start and stop commands, and the frequency reference of the drive when Remote control is active).

➔ If I/O Terminal is set as the value for Remote Control Place, the next step is shown. If Fieldbus is selected, the wizard goes directly to step 14.

12. Set a value for P1.26 Analog Input 2 Signal Range.
13. Set Local Control Place (where the drive start/stop commands, and the frequency reference is given when Local control is active).

➡ If I/O (B) Terminal is set as the value for Local Control Place, the next step is shown. With other selections, the wizard goes directly to step 16.

14. Set a value for P1.25 Analog Input 1 Signal Range.

➡ The Local/Remote application wizard is completed.

4.1.3 Multi-step Speed Application Wizard

The application wizard helps to set the basic parameters that are related to the application.

To start the Multi-step Speed application wizard, set the value Multi-step Speed to parameter P1.2 Application (ID 212) in the keypad.

If the application wizard is started from the Start-up wizard, the wizard shows only the I/O configuration.

See the range of values of the parameters in [6.1 Group 3.1: Motor Settings](#), [6.3 Group 3.3: References](#), [6.4 Group 3.4: Ramps and Brakes Setup](#).

Procedure

1. Set a value for P3.1.2.2 Motor Type (so that it agrees with the nameplate of the motor).

➡ If Motor Type is set to Induction Motor, also step 6 is shown. If the selection is PM Motor, the value of parameter P3.1.1.5 Motor Cos Phi is set to 1.00, and the wizard skips step 6.

2. Set a value for P3.1.1.1 Motor Nominal Voltage (so that it agrees with the nameplate of the motor).
3. Set a value for P3.1.1.2 Motor Nominal Frequency (so that it agrees with the nameplate of the motor).
4. Set a value for P3.1.1.3 Motor Nominal Speed (so that it agrees with the nameplate of the motor).
5. Set a value for P3.1.1.4 Motor Nominal Current (so that it agrees with the nameplate of the motor).
6. Set a value for P3.1.1.5 Motor Cos Phi (so that it agrees with the nameplate of the motor).
7. Set a value for P3.3.1.1 Minimum Frequency Reference.
8. Set a value for P3.3.1.2 Maximum Frequency Reference.
9. Set a value for P3.4.1.2 Acceleration Time 1.
10. Set a value for P3.4.1.3 Deceleration Time 1.

➡ The Multi-step Speed application wizard is completed.

4.1.4 PID Control Application Wizard

The application wizard helps to set the basic parameters that are related to the application.

To start the PID Control application wizard, set the value PID Control to parameter P1.2 Application (ID 212) in the keypad.

If the application wizard is started from the Start-up wizard, the wizard goes directly to step 11.

See the range of values of the parameters in [6.1 Group 3.1: Motor Settings](#), [6.3 Group 3.3: References](#), [6.4 Group 3.4: Ramps and Brakes Setup](#), [6.13 Group 3.13: PID Controller](#).

Procedure

1. Set a value for P3.1.2.2 Motor Type (so that it agrees with the nameplate of the motor).

➡ If Motor Type is set to Induction Motor, also step 6 is shown. If the selection is PM Motor, the value of parameter P3.1.1.5 Motor Cos Phi is set to 1.00, and the wizard skips step 6.

2. Set a value for P3.1.1.1 Motor Nominal Voltage (so that it agrees with the nameplate of the motor).
3. Set a value for P3.1.1.2 Motor Nominal Frequency (so that it agrees with the nameplate of the motor).
4. Set a value for P3.1.1.3 Motor Nominal Speed (so that it agrees with the nameplate of the motor).
5. Set a value for P3.1.1.4 Motor Nominal Current (so that it agrees with the nameplate of the motor).
6. Set a value for P3.1.1.5 Motor Cos Phi (so that it agrees with the nameplate of the motor).
7. Set a value for P3.3.1.1 Minimum Frequency Reference.
8. Set a value for P3.3.1.2 Maximum Frequency Reference.
9. Set a value for P3.4.1.2 Acceleration Time 1.

10. Set a value for P3.4.1.3 Deceleration Time 1.
11. Select a control place (where to give the start and stop commands, and the frequency reference of the drive).
12. Set a value for P3.13.1.4 Process Unit Selection.

➔ If the selection is other than %, the next steps are shown. If the selection is %, the wizard goes directly to step 17.

13. Set a value for P3.13.1.5 Process Unit Min.

The range depends on the selection in step 12.

14. Set a value for P3.13.1.6 Process Unit Max.

The range depends on the selection in step 12.

15. Set a value for P3.13.1.7 Process Unit Decimals.

16. Set a value for P3.13.3.3 Feedback 1 Source Selection.

See the table Feedback settings in chapter [6.13 Group 3.13: PID Controller](#).

➔ If analog input signal is selected, step 18 is shown. With other selections, the wizard goes to step 19.

17. Set the signal range of the analog input.
18. Set a value for P3.13.1.8 Error Inversion.
19. Set a value for P3.13.2.6 Setpoint Source Selection.

See table Setpoints in chapter [6.13 Group 3.13: PID Controller](#).

➔ If analog input signal is selected, step 21 is shown. With other selections, the wizard goes to step 23. If Keypad Setpoint 1 or Keypad Setpoint 2 are set for the value, the wizard goes directly to step 22.

20. Set the signal range of the analog input.
21. Set a value for P3.13.2.1 (Keypad Setpoint 1) and P3.13.2.2 (Keypad Setpoint 2).

Depends on the range set in step 20.

22. Using the sleep function.

➔ If value Yes is set for step 22, the next 3 steps are shown. If the value No is selected, the wizard is completed.

23. Set a value for P3.34.7 Sleep Frequency Limit.
24. Set a value for P3.34.8 Sleep Delay 1.
25. Set a value for P3.34.9 Wake-up Level.

The range depends on the set process unit.

➔ The PID Control application wizard is completed.

4.1.5 Multi-purpose Application Wizard

The application wizard helps to set the basic parameters that are related to the application.

To start the Multi-purpose application wizard, set the value Multi-purpose to parameter P1.2 Application (ID 212) in the keypad.

If the application wizard is started from the Start-up wizard, the wizard goes directly to step 11.

See the range of values of the parameters in [6.1 Group 3.1: Motor Settings](#), [6.3 Group 3.3: References](#), [6.4 Group 3.4: Ramps and Brakes Setup](#).

Procedure

1. Set a value for P3.1.2.2 Motor Type (so that it agrees with the nameplate of the motor).

➔ If Motor Type is set to Induction Motor, also step 6 is shown. If the selection is PM Motor, the value of parameter P3.1.1.5 Motor Cos Phi is set to 1.00, and the wizard skips step 6.

2. Set a value for P3.1.1.1 Motor Nominal Voltage (so that it agrees with the nameplate of the motor).
3. Set a value for P3.1.1.2 Motor Nominal Frequency (so that it agrees with the nameplate of the motor).
4. Set a value for P3.1.1.3 Motor Nominal Speed (so that it agrees with the nameplate of the motor).

5. Set a value for P3.1.1.4 Motor Nominal Current (so that it agrees with the nameplate of the motor).
6. Set a value for P3.1.1.5 Motor Cos Phi (so that it agrees with the nameplate of the motor).
7. Set a value for P3.3.1.1 Minimum Frequency Reference.
8. Set a value for P3.3.1.2 Maximum Frequency Reference.
9. Set a value for P3.4.1.2 Acceleration Time 1.
10. Set a value for P3.4.1.3 Deceleration Time 1.
11. Select a control place (where to give the start and stop commands, and the frequency reference of the drive).

➡ The Multi-purpose application wizard is completed.

4.1.6 Motor Potentiometer Application Wizard

The application wizard helps to set the basic parameters that are related to the application.

To start the Motor Potentiometer application wizard, set the value Motor Potentiometer to parameter P1.2 Application (ID 212) in the keypad.

If the application wizard is started from the Start-up wizard, the wizard goes directly to step 11.

See the range of values of the parameters in [6.1 Group 3.1: Motor Settings](#), [6.3 Group 3.3: References](#), [6.4 Group 3.4: Ramps and Brakes Setup](#).

Procedure

1. Set a value for P3.1.2.2 Motor Type (so that it agrees with the nameplate of the motor).

➡ If Motor Type is set to Induction Motor, also step 6 is shown. If the selection is PM Motor, the value of parameter P3.1.1.5 Motor Cos Phi is set to 1.00, and the wizard skips step 6.

2. Set a value for P3.1.1.1 Motor Nominal Voltage (so that it agrees with the nameplate of the motor).
3. Set a value for P3.1.1.2 Motor Nominal Frequency (so that it agrees with the nameplate of the motor).
4. Set a value for P3.1.1.3 Motor Nominal Speed (so that it agrees with the nameplate of the motor).
5. Set a value for P3.1.1.4 Motor Nominal Current (so that it agrees with the nameplate of the motor).
6. Set a value for P3.1.1.5 Motor Cos Phi (so that it agrees with the nameplate of the motor).
7. Set a value for P3.3.1.1 Minimum Frequency Reference.
8. Set a value for P3.3.1.2 Maximum Frequency Reference.
9. Set a value for P3.4.1.2 Acceleration Time 1.
10. Set a value for P3.4.1.3 Deceleration Time 1.
11. Set a value for P1.36.1 Motor Potentiometer Ramp Time.
12. Set a value for P1.36.2 Motor Potentiometer Reset.

➡ The Motor Potentiometer application wizard is completed.

4.2 Function Wizards

4.2.1 Wizards in Menu 1.1

Table 15: M1.1 Wizards

Index	Parameter	Min	Max	Unit	Default	ID	Description
1.1.1	Start-up wizard	0	1		0	1171	0 = Do not activate 1 = Activate The selection Activate starts the Start-up wizard (see 1.6.1 Start-Up Wizard).
1.1.3	Multi-pump Wizard	0	1		0	1671	The selection Activate starts the Multi-pump wizard (see 4.2.2 Multi-pump Wizard).
1.1.4	Fire mode Wizard	0	1		0	1672	The selection Activate starts the Fire mode wizard (see 4.2.3 Fire Mode Wizard).

4.2.2 Multi-pump Wizard

To start the Multi-pump wizard, make the selection Activate for parameter B1.1.3 in the Quick setup menu. The default settings tell to use the PID controller in the one feedback/one setpoint mode. The default control place is I/O A, and the default process unit is %.

See the range of values of the parameters in [6.13 Group 3.13: PID Controller](#), [6.17 Group 3.17: Fire Mode](#).

Procedure

1. Set a value for P3.13.1.4 Process Unit Selection.

➔ If the selection is other than %, the next steps are shown. If the selection is %, the wizard goes directly to step 5.

2. Set a value for P3.13.1.5 Process Unit Min.
3. Set a value for P3.13.1.6 Process Unit Max.
4. Set a value for P3.13.1.7 Process Unit Decimals.
5. Set a value for P3.13.3.3 Feedback 1 Source Selection.

See the table Feedback settings in chapter [6.13 Group 3.13: PID Controller](#).

➔ If analog input signal is selected, step 6 is shown. With other selections, the wizard goes to step 7.

6. Set the signal range of the analog input.

See table Analog inputs in chapter [6.5 Group 3.5: I/O Configuration](#).

7. Set a value for P3.13.1.8 Error Inversion.
8. Set a value for P3.13.2.6 Setpoint Source 1 Selection.

See table Setpoints in chapter [6.13 Group 3.13: PID Controller](#).

➔ If analog input signal is selected, step 9 is shown. With other selections, the wizard goes to step 11. If Keypad Setpoint 1 or Keypad Setpoint 2 is selected for the value, step 10 is shown.

9. Set the signal range of the analog input.

See table Analog inputs in chapter [6.5 Group 3.5: I/O Configuration](#).

10. Set a value for P3.13.2.1 (Keypad setpoint 1) and P3.13.2.2 (Keypad setpoint 2).
11. Using the sleep function.

➔ If the value "Yes" in given step 11, the next 3 steps are shown.

12. Set a value for P3.13.5.1 Sleep Frequency Limit 1.
13. Set a value for P3.13.5.2 Sleep Delay 1.
14. Set a value for P3.13.5.6 Wake-up Level 1.
15. Set a value for P3.15.1 Number of Motors.
16. Set a value for P3.15.2 Interlock Function.
17. Set a value for P3.15.4 Autochange.

➔ If the Autochange function is enabled, the next 3 steps are shown. If the Autochange function is not used, the wizard goes directly to step 21.

18. Set a value for P3.15.3 Include FC.
19. Set a value for P3.15.5 Autochange Interval.
20. Set a value for P3.15.6 Autochange: Frequency Limit.
21. Set a value for P3.15.8 Bandwidth.
22. Set a value for P3.15.9 Bandwidth Delay.

After this, the display shows the digital input and relay output configuration that the application does automatically. Write down these values. This function is not available in the text display.

4.2.3 Fire Mode Wizard

To start the Fire Mode Wizard, make the selection Activate for parameter B1.1.4 in the Quick setup menu. See [11.20.1 The Fire Mode Function](#) for information on the password and warranty.

See the range of values of the parameters in [6.17 Group 3.17: Fire Mode](#).

NOTICE

Before continuing, read about the password and warranty.

Procedure

1. Set a value for parameter P3.17.2 Fire Mode Frequency Source.

 If other value than Fire mode frequency is selected, the wizard goes directly to step 3.

2. Set a value for parameter P3.17.3 Fire Mode Frequency.
3. Activate the signal when the contact opens or when it closes.
4. Set a value for parameters P3.17.4 Fire Mode Activation on OPEN/P3.17.5 Fire Mode Activation on CLOSE.

See also chapter [11.8.1.1 General Information on the Programming](#).

5. Set a value for parameter P3.17.6 Fire Mode Reverse.
6. Set a value for P3.17.1 Fire Mode Password.

5 Monitor Menu

5.1 Uses of the Monitor Menu

Monitor Menu allows monitoring the actual values of the parameters and signals. It also allows monitoring the statuses and measurements. Some of the values to be monitored can be customized.

5.2 Multimonitor Monitoring

5.2.1 Changing the Items to Monitor

On the *Multimonitor* page, 4–9 items to monitor can be collected. Select the number of items with the parameter 3.11.4 Multimonitor View. See more in [6.11 Group 3.11: Application Settings](#).

Procedure

1. Go into the *Monitor* menu with the [OK] button.
2. Go into *Multimonitor*.
3. To replace an old item, activate it. Use the arrow buttons.

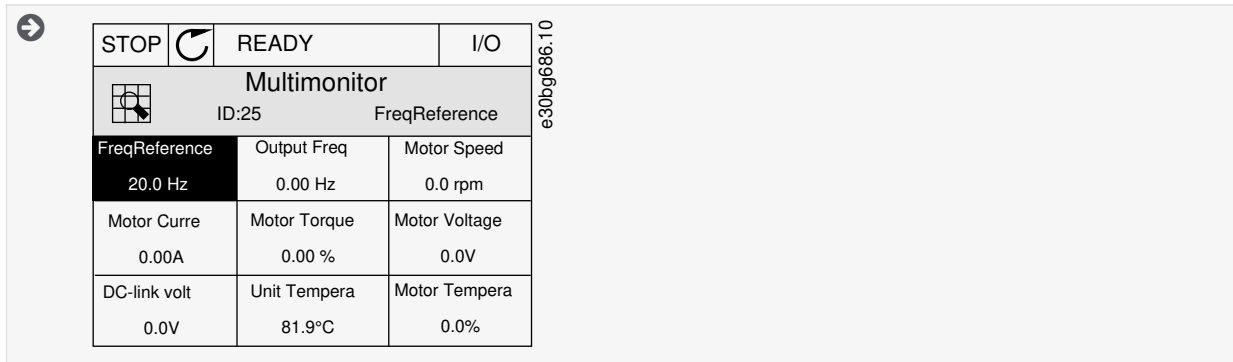

4. To select a new item in the list, push [OK].

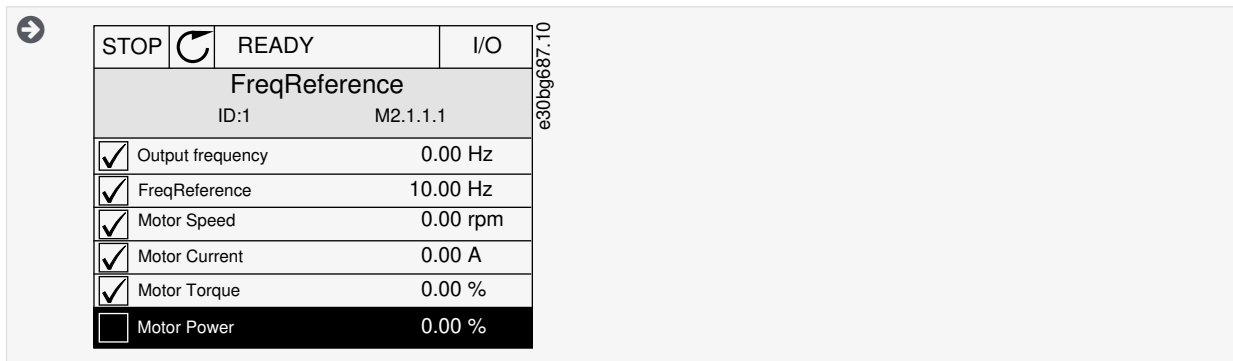

5.3 Trend Curve Monitoring

5.3.1 Uses of the Trend Curve

The Trend curve is a graphical presentation of 2 monitor values.

When a value is selected, the drive starts to record the values. The *Trend curve* submenu allows examining the trend curve, and making the signal selections. Also the minimum and maximum settings and the sampling interval, and use autoscaling can be given there.

5.3.2 Changing the Values in Trend Curve Monitoring

Procedure

1. In the *Monitor* menu, find the *Trend curve* submenu and push [OK].
2. Go into the submenu *View trend curve* with the [OK] button.

- To select the current value that to change, use the arrow buttons up and down. Push [OK].

Only 2 values as trend curves can be monitored at the same time. The current selections, *FreqReference*, and *Motor speed*, are at the bottom of the display.

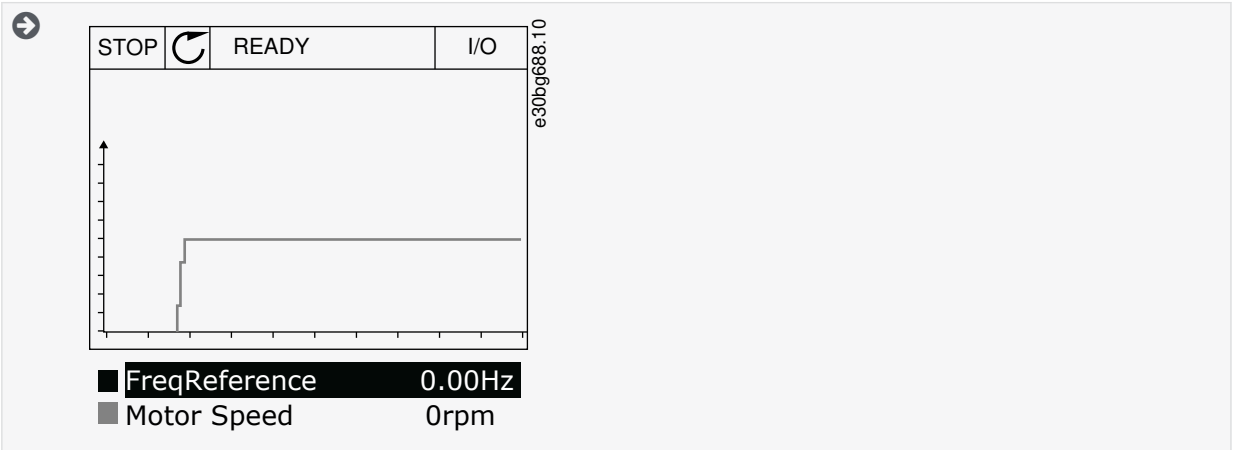

- Go through the list of the monitoring values with the arrow buttons.

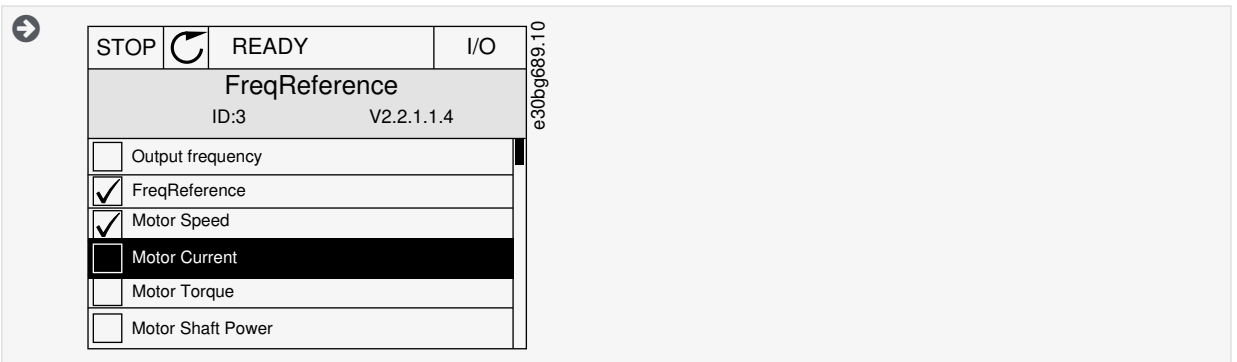

- Make a selection and push [OK].

5.3.3 Stopping the Progression of the Curve

The *Trend curve* function allows stopping the curve and reading the current values. After, the progression of the curve can be restarted.

Procedure

- In *Trend curve* view, activate a curve with the arrow button Up.

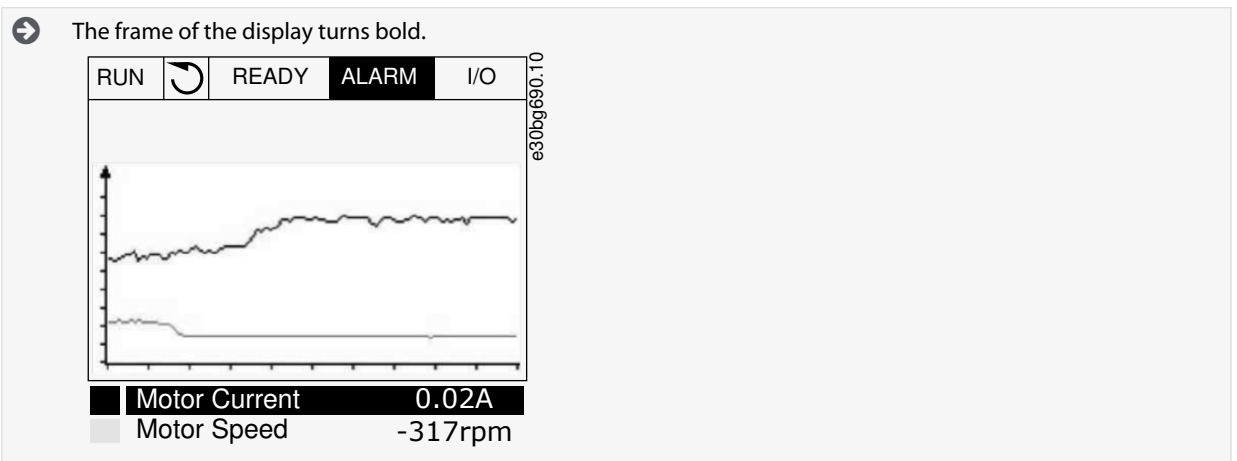

- Push [OK] at the target point of the curve.

A vertical line comes into view on the display. The values at the bottom of the display agree to the location of the line.

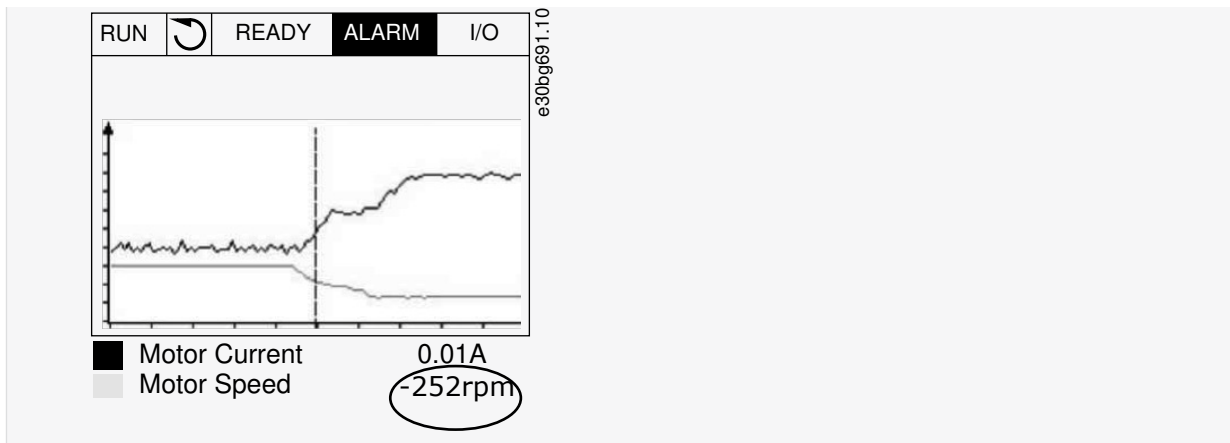

3. To move the line to see the values of some other location, use the arrow buttons Left and Right.

5.3.4 Trend Curve Parameters

Table 16: The Trend Curve Parameters

Index	Parameter	Min	Max	Unit	Default	ID	Description
M2.2.1	View Trend curve						Go into this menu to monitor values in a curve form.
P2.2.2	Sampling interval	100	432000	ms	100	2368	
P2.2.3	Channel 1 min	-214748	1000		-1000	2369	
P2.2.4	Channel 1 max	-1000	214748		1000	2370	
P2.2.5	Channel 2 min	-214748	1000		-1000	2371	
P2.2.6	Channel 2 max	-1000	214748		1000	2372	
P2.2.7	Autoscale	0	1		0	2373	0 = Disabled 1 = Enabled

5.4 Basic Monitoring

5.4.1 Uses of the Basic Monitoring

Only the standard I/O board statuses are available in the Monitor menu. For the statuses of all the I/O board signals as raw data, see the I/O and Hardware menu.

Check the statuses of the expander I/O board in the I/O and Hardware menu when the system asks.

5.4.2 Basic Monitoring Parameters

Table 17: Items in the Basic Monitoring Menu

Index	Monitoring value	Unit	Scale	ID	Description
V2.3.1	Output frequency	Hz	0.01	1	
V2.3.2	Frequency reference	Hz	0.01	25	
V2.3.3	Motor speed	RPM	1	2	
V2.3.4	Motor current	A	Varies	3	
V2.3.5	Motor torque	%	0.1	4	
V2.3.7	Motor shaft power	%	0.1	5	

Index	Monitoring value	Unit	Scale	ID	Description
V2.3.8	Motor shaft power	kW/hp	Varies	73	
V2.3.9	Motor voltage	V	0.1	6	
V2.3.10	DC link voltage	V	1	7	
V2.3.11	Unit temperature	°C	0.1	8	
V2.3.12	Motor temperature	%	0.1	9	
V2.3.13	Motor Preheat		1	1228	0 = OFF 1 = Heating (feeding DC-current)
V2.3.14	Torque reference	%	0.1	18	

5.5 I/O Monitoring

Table 18: I/O Signal Monitoring

Index	Monitoring value	Unit	Scale	ID	Description
V2.4.1	Slot A DIN 1, 2, 3		1	15	
V2.4.2	Slot A DIN 4, 5, 6		1	16	
V2.4.3	Slot B RO 1, 2, 3		1	17	
V2.4.4	Analog input 1	%	0.01	59	Slot A.1 as default.
V2.4.5	Analog input 2	%	0.01	60	Slot A.2 as default.
V2.4.6	Analog input 3	%	0.01	61	Slot D.1 as default.
V2.4.7	Analog input 4	%	0.01	62	Slot D.2 as default.
V2.4.8	Analog input 5	%	0.01	75	Slot E.1 as default.
V2.4.9	Analog input 6	%	0.01	76	Slot E.2 as default.
V2.4.10	Slot A AO1	%	0.01	81	

5.6 Temperature Inputs

Table 19: Monitoring the Temperature Inputs

Index	Monitoring value	Unit	Scale	ID	Description
V2.5.1 ⁽¹⁾	Temperature input 1	°C	0.1	50	
V2.5.2 ⁽¹⁾	Temperature input 2	°C	0.1	51	
V2.5.3 ⁽¹⁾	Temperature input 3	°C	0.1	52	
V2.5.4 ⁽¹⁾	Temperature input 4	°C	0.1	69	
V2.5.5 ⁽¹⁾	Temperature input 5	°C	0.1	70	
V2.5.6 ⁽¹⁾	Temperature input 6	°C	0.1	71	

¹ This parameter group is visible with an option board for temperature measurement (OPTBH).

5.7 Extras and Advanced

Table 20: Monitoring of the Advanced Values

Index	Monitoring value	Unit	Scale	ID	Description
V2.6.1	Drive Status Word		1	43	B1 = Ready B2 = Run B3 = Fault B6 = Run Enable B7 = Alarm Active B10 = DC current in stop B11 = DC brake active B12 = Run Request B13 = Motor Regulator Active B15 = Brake Chopper Active
V2.6.2	Ready status		1	78	B0 = Run Enable high B1 = No fault active B2 = Charge switch closed B3 = DC voltage within limits B4 = Power manager initialised B5 = Power unit is not blocking start B6 = System software is not blocking start
V2.6.3	Application Status Word1		1	89	B0 = Interlock 1 B1 = Interlock 2 B2 = Reserved B3 = Ramp 2 active B4 = Mechanical brake control B5 = I/O A control active B6 = I/O B control active B7 = Fieldbus Control Active B8 = Local control active B9 = PC control active B10 = Preset frequencies active B11 = Jogging active B12 = Fire Mode active B13 = Motor Preheat active B14 = Quick stop active B15 = Drive stopped from keypad
V2.6.4	Application Status Word2		1	90	B0 = Acc/Dec prohibited B1 = Motor switch open B5 = Jockey pump active B6 = Priming pump active B7 = Input pressure supervision (Alarm/ Fault) B8 = Frost protection (Alarm/Fault) B9 = Autocleaning active
V2.6.5	DIN Status Word 1		1	56	
V2.6.6	DIN Status Word 2		1	57	
V2.6.7	Motor current 1 decimal		0.1	45	

Index	Monitoring value	Unit	Scale	ID	Description
V2.6.8	Frequency reference source		1	1495	0 = PC 1 = Preset Freqs 2 = Keypad Reference 3 = Fieldbus 4 = AI1 5 = AI2 6 = AI1+AI2 7 = PID Controller 8 = Motor Potentiom. 9 = Joystick 10 = Jogging 100 = Not defined 101 = Alarm, PresetFreq 102 = Auto-cleaning
V2.6.9	Last active fault code		1	37	
V2.6.10	Last active fault ID		1	95	
V2.6.11	Last active alarm code		1	74	
V2.6.12	Last active alarm ID		1	94	
V2.6.13	Motor regulator status		1	77	B0 = Current Limit (Motor) B1 = Current Limit (Generator) B2 = Torque Limit (Motor) B3 = Torque Limit (Generator) B4 = Overvoltage Control B5 = Undervoltage Control B6 = Power Limit (Motor) B7 = Power Limit (Generator)
V2.6.14	Motor Shaft Power 1 Decimal	kW/hp		98	

5.8 Timer Functions Monitoring

Table 21: Monitoring of the Timer Functions

Index	Monitoring value	Unit	Scale	ID	Description
V2.7.1	TC 1, TC 2, TC 3		1	1441	
V2.7.2	Interval 1		1	1442	
V2.7.3	Interval 2		1	1443	
V2.7.4	Interval 3		1	1444	
V2.7.5	Interval 4		1	1445	
V2.7.6	Interval 5		1	1446	
V2.7.7	Timer 1	s	1	1447	

Index	Monitoring value	Unit	Scale	ID	Description
V2.7.8	Timer 2	s	1	1448	
V2.7.9	Timer 3	s	1	1449	
V2.7.10	Real-time clock			1450	

5.9 PID Controller Monitoring

Table 22: Monitoring of the Values of the PID Controller

Index	Monitoring value	Unit	Scale	ID	Description
V2.8.1	PID1 setpoint	Varies	As is set in P3.13.1.7 (See 6.13 Group 3.13: PID Controller.)	20	
V2.8.2	PID1 feedback	Varies	As is set in P3.13.1.7	21	
V2.8.3	PID1 error value	Varies	As is set in P3.13.1.7	22	
V2.8.4	PID1 output	%	0.01	23	
V2.8.5	PID1 status		1	24	0 = Stopped 1 = Running 3 = Sleep mode 4 = In dead band (see 6.13 Group 3.13: PID Controller)

5.10 External PID Controller Monitoring

Table 23: Monitoring of the Values of the External PID Controller

Index	Monitoring value	Unit	Scale	ID	Description
V2.9.1	ExtPID Setpoint	Varies	As set in P3.14.1.10 (See 6.14 Group 3.14: External PID Controller.)	83	
V2.9.2	ExtPID Feedback	Varies	As set in P3.14.1.10	84	
V2.9.3	ExtPID Error	Varies	As set in P3.14.1.10	85	
V2.9.4	ExtPID Output	%	0.01	86	
V2.9.5	ExtPID Status		1	87	0 = Stopped 1 = Running 2 = In dead band (See 6.14 Group 3.14: External PID Controller.)

5.11 Multi-pump Monitoring

Table 24: Multi-pump Monitoring

Index	Monitoring value	Unit	Scale	ID	Description
V2.10.1	Motors Running		1	30	
V2.10.2	Autochange		1	1114	

5.12 Monitoring of Maintenance Counters

Table 25: Maintenance Counter Monitoring

Index	Monitoring value	Unit	Scale	ID	Description
V2.11.1	Maintenance Counter 1	h/kRev	Varies	1101	

5.13 Fieldbus Process Data Monitoring

Table 26: Fieldbus Process Data Monitoring

Index	Monitoring value	Unit	Scale	ID	Description
V2.12.1	FB Control Word			874	
V2.12.2	FB Status Word			864	
V2.12.3	FB Speed Reference			875	
V2.12.4	FB Speed Actual			865	
V2.12.5	Fieldbus General Control Word			861	
V2.12.6	Fieldbus General Status Word			862	

Table 27: Fieldbus Data In

Index	Monitoring value	Unit	Scale	ID	Description
V2.12.7.1	FB Data In 1		1	876	
V2.12.7.2	FB Data In 2		1	877	
V2.12.7.3	FB Data In 3		1	878	
V2.12.7.4	FB Data In 4		1	879	
V2.12.7.5	FB Data In 5		1	880	
V2.12.7.6	FB Data In 6		1	881	
V2.12.7.7	FB Data In 7		1	882	
V2.12.7.8	FB Data In 8		1	883	
V2.12.7.9	FB Data In 9		1	229	
V2.12.7.10	FB Data In 10		1	230	
V2.12.7.11	FB Data In 11		1	231	
V2.12.7.12	FB Data In 12		1	232	
V2.12.7.13	FB Data In 13		1	233	
V2.12.7.14	FB Data In 14		1	234	
V2.12.7.15	FB Data In 15		1	235	
V2.12.7.16	FB Data In 16		1	236	

Table 28: Fieldbus Data Out

Index	Monitoring value	Unit	Scale	ID	Description
V2.12.8.1	FB Data Out 1		1	866	
V2.12.8.2	FB Data Out 2		1	867	
V2.12.8.3	FB Data Out 3		1	868	
V2.12.8.4	FB Data Out 4		1	869	
V2.12.8.5	FB Data Out 5		1	870	
V2.12.8.6	FB Data Out 6		1	871	
V2.12.8.7	FB Data Out 7		1	872	
V2.12.8.8	FB Data Out 8		1	873	
V2.12.8.9	FB Data Out 9		1	245	
V2.12.8.10	FB Data Out 10		1	246	
V2.12.8.11	FB Data Out 11		1	247	
V2.12.8.12	FB Data Out 12		1	248	
V2.12.8.13	FB Data Out 13		1	249	
V2.12.8.14	FB Data Out 14		1	250	
V2.12.8.15	FB Data Out 15		1	251	
V2.12.8.16	FB Data Out 16		1	252	

5.14 Drive Customizer Monitoring

Table 29: Drive Customizer Monitoring

Index	Monitoring value	Unit	Scale	ID	Description
V2.13.2	Block Out.1			15020	
V2.13.3	Block Out.2			15040	
V2.13.4	Block Out.3			15060	
V2.13.5	Block Out.4			15080	
V2.13.6	Block Out.5			15100	
V2.13.7	Block Out.6			15120	
V2.13.8	Block Out.7			15140	
V2.13.9	Block Out.8			15160	
V2.13.10	Block Out.9			15180	
V2.13.11	Block Out.10			15200	

5.15 Condition-based Monitoring

Table 30: Condition-based Monitoring

Index	Name	Min	Max	Unit	Default	ID	Description
V2.16.1 Baseline Data							
V2.16.1.1	BaselineDataElem1	-300.00	320.00	various	0.00	3601	
V2.16.1.2	BaselineDataElem2	-300.00	320.00	various	0.00	3602	
V2.16.1.3	BaselineDataElem3	-300.00	320.00	various	0.00	3603	
V2.16.1.4	BaselineDataElem4	-300.00	320.00	various	0.00	3604	
V2.16.1.5	BaselineDataElem5	-300.00	320.00	various	0.00	3605	
V2.16.1.6	BaselineDataElem6	-300.00	320.00	various	0.00	3606	
V2.16.1.7	BaselineDataElem7	-300.00	320.00	various	0.00	3607	
V2.16.1.8	BaselineDataElem8	-300.00	320.00	various	0.00	3608	
V2.16.1.9	BaselineDataElem9	-300.00	320.00	various	0.00	3609	
V2.16.1.10	BaselineDataElem10	-300.00	320.00	various	0.00	3610	
V2.16.1.11	BaselineRun Status	0	14		0	3622	0=Not Started 1=Running 2=Running 10% 3=Running 20% 4=Running 30% 5=Running 40% 6=Running 50% 7=Running 60% 8=Running 70% 9=Running 80% 10=Running 90% 11=Completed 12=Run Failed 13=Manual Before Baseline 14=Manual After Baseline
V2.16.2 Stator Winding Monitor							
V2.16.2.1	Current Unbalance	0.00	100.00	%	0.00	3617	
V2.16.2.2	Current Threshold Value	0.00	100.00	%	0.00	3620	
V2.16.2.3	Current Warning S1 High Threshold	0.00	100.00	%	0.00	3611	
V2.16.2.4	Current Warning S2 High Threshold	0.00	100.00	%	0.00	3612	
V2.16.2.5	Current Alarm High Threshold	0.00	100.00	%	0.00	3613	
V2.16.3 Vibration							
V2.16.3.1	Vibration	0.00	100.00	%	0.00	3623	
V2.16.3.2	Vibration Threshold Value	0.00	100.00	%	0.00	3624	

Index	Name	Min	Max	Unit	Default	ID	Description
V2.16.3.3	Vibration Warning S1 High Threshold	0.00	100.00	%	0.00	3625	
V2.16.3.4	Vibration Warning S2 High Threshold	0.00	100.00	%	0.00	3626	
V2.16.3.5	Vibration Alarm High Threshold	0.00	100.00	%	0.00	3627	
V2.16.4 Load							
V2.16.4.1	Motor Torque	-300.0	300.0	%	0.0	4	
V2.16.4.2	Load Threshold Value	-300.0	300.0	%	0.00	3628	
V2.16.4.3	Load Warning S1 High Threshold	-300.0	300.0	%	0.00	3629	
V2.16.4.4	Load Warning S2 High Threshold	-300.0	300.0	%	0.00	3630	
V2.16.4.5	Load Alarm High Threshold	-300.0	300.0	%	0.00	3631	
V2.16.4.6	Load Warning S1 Low Threshold	-300.0	300.0	%	0.00	3632	
V2.16.4.7	Load Warning S2 Low Threshold	-300.0	300.0	%	0.00	3633	
V2.16.4.8	Load Alarm Low Threshold	-300.0	300.0	%	0.00	3634	
V2.16.5	Condition Based Monitoring Status	0	65535		0	3619	B0= Stator current warning S1 B2= Vibration warning S1 B3= Load warning S1 B5= Stator current warning S2 B7= Vibration warning S2 B8= Load warning S2 B10= Stator current alarm/ fault B12= Vibration alarm/fault B13= Load alarm/fault

6 Parameters Menu

6.1 Group 3.1: Motor Settings

Table 31: Motor Nameplate Parameters

Index	Parameter	Min	Max	Unit	Default	ID	Description
P3.1.1.1	Motor Nominal Voltage	Varies	Varies	V	Varies	110	
P3.1.1.2	Motor Nominal Frequency	8.00	320.00	Hz	50/60	111	
P3.1.1.3	Motor Nominal Speed	24	19200	RPM	Varies	112	
P3.1.1.4	Motor Nominal Current	IH * 0.1	IH * 2	A	Varies	113	
P3.1.1.5	Motor Cos Phi (Power Factor)	0.30	1.00		Varies	120	
P3.1.1.6	Motor Nominal Power	Varies	Varies	kW	Varies	116	

Table 32: Motor Control Settings

Index	Parameter	Min	Max	Unit	Default	ID	Description
P3.1.2.1	Control Mode	0	2		0	600	0 = Frequency control 1 = Speed control 2 = Torque control
P3.1.2.2	Motor Type	0	2		0	650	0 = Induction motor 1 = PM motor 2 = Reluctance motor
P3.1.2.3	Switching Frequency	1.5	Max Switching frequency (ID 2620)	kHz	Varies	601	
P3.1.2.4	Identification	0	2		0	631	0 = No action 1 = At standstill 2 = With rotation
P3.1.2.5	Magnetizing Current	0.0	2*IH	A	0.0	612	
P3.1.2.6	Motor Switch	0	1		0	653	0 = Disabled 1 = Enabled
P3.1.2.7	Load Drooping	0.00	20.00	%	0.00	620	
P3.1.2.8	Load Drooping Time	0.00	2.00	s	0.00	656	
P3.1.2.9	Load Drooping Mode	0	1		0	1534	0 = Normal 1 = Linear removal
P3.1.2.10	Overvoltage Control	0	1		1	607	0 = Disabled 1 = Enabled
P3.1.2.11	Undervoltage Control	0	1		1	608	0 = Disabled 1 = Enabled

Index	Parameter	Min	Max	Unit	Default	ID	Description
P3.1.2.12	Energy Optimization	0	1		0	666	0 = Disabled 1 = Enabled
P3.1.2.13	Stator Voltage Adjust	50.0	150.0	%	100.0	659	
P3.1.2.14	Overmodulation	0	1		1	1515	0 = Disabled 1 = Enabled
P3.1.2.15	Rs Voltage Drop	0.00	50.00	%	0.00	662	
P3.1.2.16	Ls Voltage Drop	0.00	200.00	%	0.00	673	
P3.1.2.17	Motor BEM Voltage	0	Varies	V	0	674	

Table 33: Motor Limit Settings

Index	Parameter	Min	Max	Unit	Default	ID	Description
P3.1.3.1	Motor Current Limit	IH*0.1	IS	A	Varies	107	
P3.1.3.2	Motor Torque Limit	0.0	300.0	%	300.0	1287	
P3.1.3.3	Generator Torque Limit	0.0	300.0	%	300.0	1288	
P3.1.3.4	Motor Power Limit	0.0	300.0	%	300.0	1289	
P3.1.3.5	Generator Power Limit	0.0	300.0	%	300.0	1290	

Table 34: Open Loop Settings

Index	Parameter	Min	Max	Unit	Default	ID	Description
P3.1.4.1	U/f Ratio	0	2		0	108	0 = Linear 1 = Squared 2 = Programmable
P3.1.4.2	Field Weakening Point Frequency	8.00	P3.3.1.2	Hz	Varies	602	
P3.1.4.3	Voltage at Field Weakening Point	10.00	200.00	%	100.00	603	
P3.1.4.4	U/f Midpoint Frequency	0.00	P3.1.4.2	Hz	Varies	604	
P3.1.4.5	U/f Midpoint Voltage	0.0	100.0	%	100.00	605	
P3.1.4.6	Zero Frequency Voltage	0.00	40.00	%	Varies	606	
P3.1.4.7	Flying Start Options	0	255		0	1590	B0 = Search the shaft frequency only from the same direction as the frequency reference B1 = Disable AC scanning

Index	Parameter	Min	Max	Unit	Default	ID	Description
							B4 = Use the frequency reference for the initial guess B5 = Disable DC pulses B6 = Flux build with current control B7 = Reverse injection direction
P3.1.4.8	Flying Start Scan Current	0.0	100.0	%	45.0	1610	
P3.1.4.9	Auto Torque Boost	0	1		0	109	0 = Disabled 1 = Enabled
P3.1.4.10	Torque Boost Motor Gain	0.0	100.0	%	100.0	667	
P3.1.4.11	Torque Boost Generator Gain	0.0	100.0	%	0.0	665	
M3.1.4.12	I/f Start	This menu includes 3 parameters. See Table 35 .					

Table 35: I/f Start Parameters

Index	Parameter	Min	Max	Unit	Default	ID	Description
P3.1.4.12.1	I/f Start	0	1		0	534	0 = Disabled 1 = Enabled
P3.1.4.12.2	I/f Start Frequency	5.0	0.5 * P3.1.1.2		0.2 * P3.1.1.2	535	
P3.1.4.12.3	I/f Start Current	0.0	150.0	%	80.0	536	

Table 36: Torque Stabilator Parameters

Index	Parameter	Min	Max	Unit	Default	ID	Description
P3.1.4.13.1	Torque Stabilator Gain	0.0	500.0	%	50.0	1412	
P3.1.4.13.2	Torque Stabilator Gain at Field Weakening Point	0.0	500.0	%	50.0	1414	
P3.1.4.13.3	Torque Stabilator Damping Time Constant	0.0005	1.0000	s	0.0050	1413	
P3.1.4.13.4	Torque Stabilator Damping Time Constant for PM motors	0.0005	1.0000	s	0.0500	1735	
P3.1.4.13.5	Torque Stabilator Filter Time Constant	0.0000	0.5000	s	0.0005	15650	
P3.1.4.13.6	Torque Stabilator Filter Time Constant for PM motors	0.0000	0.5000	s	0.0005	15651	

Table 37: Sensorless Control Settings

Index	Parameter	Min	Max	Unit	Default	ID	Description
P3.1.6.1	Sensorless Control	0	1		0	1724	0 = Disabled

Index	Parameter	Min	Max	Unit	Default	ID	Description
							1 = Enabled
P3.1.6.3	Sensorless Control Options				16384	1726	B0 = Stator resistance identification B3 = Limit frequency polarity B6 = Enable IR-compensation adjust B8 = Voltage based current limit B14 = Ramp antiwindup
P3.1.6.8	Speed Control Gain	0.00	500.00		20.00	1733	
P3.1.6.9	Speed Control Time	0.00	100.00		0.100	1734	
P3.1.6.14	Flux Reference	30	130		100	1250	

6.2 Group 3.2: Start/Stop Setup

Table 38: Start/Stop Setup

Index	Parameter	Min	Max	Unit	Default	ID	Description
P3.2.1	Remote Control Place	0	1		0 ⁽¹⁾	172	0 = I/O control 1 = Fieldbus control
P3.2.2	Local/Remote	0	1		0 ⁽¹⁾	211	0 = Remote 1 = Local
P3.2.3	Keypad Stop Button	0	1		0	114	0 = Yes 1 = No
P3.2.4	Start Function	0	1		0	505	0 = Ramping 1 = Flying start
P3.2.5	Stop Function	0	1		0	506	0 = Coasting 1 = Ramping
P3.2.6	I/O A Start/Stop Logic	0	4		2 ⁽¹⁾	300	Logic = 0 <ul style="list-style-type: none"> Ctrl sgn 1 = Forward Ctrl sgn 2 = Backward Logic = 1 <ul style="list-style-type: none"> Ctrl sgn 1 = Forward (edge) Ctrl sgn 2 = Inverted Stop Ctrl sgn 3 = Bckwrd (edge) Logic = 2 <ul style="list-style-type: none"> Ctrl sgn 1 = Forward (edge) Ctrl sgn 2 = Bckwrd (edge) Logic = 3 <ul style="list-style-type: none"> Ctrl sgn 1 = Start Ctrl sgn 2 = Reverse Logic = 4

Index	Parameter	Min	Max	Unit	Default	ID	Description
							<ul style="list-style-type: none"> Ctrl sgn 1 = Start (edge) Ctrl sgn 2 = Reverse
P3.2.7	I/O B Start/Stop Logic	0	4		2 ⁽¹⁾	363	See P3.2.6.
P3.2.8	Fieldbus Start Logic	0	1		0	889	0 = A rising edge is necessary 1 = State
P3.2.9	Start Delay	0.000	60.000	s	0.000	524	
P3.2.10	Remote to Local Function	0	2		2	181	0 = Keep Run 1 = Keep Run & Reference 2 = Stop

¹ The selection of the application with parameter P1.2 Application gives the default value. See [11.27 Default Values of Parameters in the Different Applications](#).

6.3 Group 3.3: References

Table 39: Frequency Reference Parameters

Index	Parameter	Min	Max	Unit	Default	ID	Description
P3.3.1.1	Minimum Frequency Reference	0.00	P3.3.1.2	Hz	0.00	101	
P3.3.1.2	Maximum Frequency Reference	P3.3.1.1	320.00	Hz	50.00/60.00	102	
P3.3.1.3	Positive Frequency Reference Limit	-320.0	320.0	Hz	320.00	1285	
P3.3.1.4	Negative Frequency Reference Limit	-320.0	320.0	Hz	-320.00	1286	
P3.3.1.5	I/O Control Reference A Selection	1	20		6 ⁽¹⁾	117	1 = Preset Frequency 0 2 = Keypad reference 3 = Fieldbus 4 = AI1 5 = AI2 6 = AI1+AI2 7 = PID reference 8 = Motor potentiometer 9 = Joystick reference 10 = Jogging reference 11 = Block Out.1 12 = Block Out.2 13 = Block Out.3 14 = Block Out.4 15 = Block Out.5 16 = Block Out.6 17 = Block Out.7 18 = Block Out.8 19 = Block Out.9 20 = Block Out.10

Index	Parameter	Min	Max	Unit	Default	ID	Description
P3.3.1.6	I/O Control Reference B Selection	1	20		4 ⁽¹⁾	131	See P3.3.1.5.
P3.3.1.7	Keypad Control Reference Selection	1	20		2 ⁽¹⁾	121	1 = Preset Frequency 0 2 = Keypad reference 3 = Fieldbus 4 = AI1 5 = AI2 6 = AI1+AI2 7 = PID reference 8 = Motor potentiometer 9 = Joystick reference 10 = Jogging reference 11 = Block Out.1 12 = Block Out.2 13 = Block Out.3 14 = Block Out.4 15 = Block Out.5 16 = Block Out.6 17 = Block Out.7 18 = Block Out.8 19 = Block Out.9 20 = Block Out.10
P3.3.1.8	Keypad Reference	P3.3.1.1	P3.3.1.2	Hz	0.00	184	
P3.3.1.9	Keypad Direction	0	1		0	123	0 = Forward 1 = Reverse
P3.3.1.10	Fieldbus Control Reference Selection	1	20		3 ⁽¹⁾	122	1 = Preset Frequency 0 2 = Keypad reference 3 = Fieldbus 4 = AI1 5 = AI2 6 = AI1+AI2 7 = PID reference 8 = Motor potentiometer 9 = Joystick reference 10 = Jogging reference 11 = Block Out.1 12 = Block Out.2 13 = Block Out.3 14 = Block Out.4 15 = Block Out.5 16 = Block Out.6 17 = Block Out.7 18 = Block Out.8 19 = Block Out.9

Index	Parameter	Min	Max	Unit	Default	ID	Description
							20 = Block Out.10

¹ The selection of the application with parameter P1.2 Application gives the default value. See the default values in [11.27 Default Values of Parameters in the Different Applications](#).

Table 40: Torque Reference Parameters

Index	Parameter	Min	Max	Unit	Default	ID	Description
P3.3.2.1	Torque Reference Selection	0	26		0 ⁽¹⁾	641	0 = Not used 1 = Keypad 2 = Joystick 3 = AI1 4 = AI2 5 = AI3 6 = AI4 7 = AI5 8 = AI6 9 = ProcessDataIn 1 10 = ProcessDataIn 2 11 = ProcessDataIn 3 12 = ProcessDataIn 4 13 = ProcessDataIn 5 14 = ProcessDataIn 6 15 = ProcessDataIn 7 16 = ProcessDataIn 8 17 = Block Out.1 18 = Block Out.2 19 = Block Out.3 20 = Block Out.4 21 = Block Out.5 22 = Block Out.6 23 = Block Out.7 24 = Block Out.8 25 = Block Out.9 26 = Block Out.10
P3.3.2.2	Torque Minimum Reference	-300.0	300.0	%	0.0	643	
P3.3.2.3	Torque Maximum Reference	-300.0	300.0	%	100.0	642	
P3.3.2.4	Torque Reference Filter Time	0.00	300.00	s	0.00	1244	
P3.3.2.5	Torque Reference Dead Zone	0.0	300.00	%	0.0	1246	
P3.3.2.6	Keypad Torque Reference	0.0	P3.3.2.3	%	0.0	1439	
P3.3.2.7	Torque Control Frequency Limit	0	1		0	1278	0 = Pos/Neg frequency limits

Index	Parameter	Min	Max	Unit	Default	ID	Description
							1 = Frequency reference
P3.3.2.8	Torque Control Open Loop	This menu includes 3 parameters. See Table 41 .					
P3.3.2.9	Torque Control Sensorless	This menu includes 2 parameters. See Table 42 .					

¹ The selection of the application with parameter P1.2 Application gives the default value. See the default values in [11.27 Default Values of Parameters in the Different Applications](#).

Table 41: Parameters for Torque Control in Open Loop Control

Index	Parameter	Min	Max	Unit	Default	ID	Description
P3.3.2.8.1	Open Loop Torque Control Minimum Frequency	0.0	P3.3.1.2	Hz	3.0	636	
P3.3.2.8.2	Open Loop Torque Control P Gain	0.0	32000.0		0.01	639	
P3.3.2.8.3	Open Loop Torque Control I Gain	0.0	32000.0		2.0	640	

Table 42: Parameters for Torque Control in Advanced Sensorless Control

Index	Parameter	Min	Max	Unit	Default	ID	Description
P3.3.2.9.1	Sensorless Torque Control P Gain	0.00	214748.36		0.06	1731	
P3.3.2.9.2	Sensorless Torque Control I Gain	0.00	214748.36		5.00	1732	

Table 43: Preset Frequency Parameters

Index	Parameter	Min	Max	Unit	Default	ID	Description
P3.3.3.1	Preset Frequency Mode	0	1		0 ⁽¹⁾	182	0 = Binary coded 1 = Number of inputs
P3.3.3.2	Preset Frequency 0	P3.3.1.1	P3.3.1.2	Hz	5.00	180	
P3.3.3.3	Preset Frequency 1	P3.3.1.1	P3.3.1.2	Hz	10.00 ⁽¹⁾	105	
P3.3.3.4	Preset Frequency 2	P3.3.1.1	P3.3.1.2	Hz	15.00 ⁽¹⁾	106	
P3.3.3.5	Preset Frequency 3	P3.3.1.1	P3.3.1.2	Hz	20.00 ⁽¹⁾	126	
P3.3.3.6	Preset Frequency 4	P3.3.1.1	P3.3.1.2	Hz	25.00 ⁽¹⁾	127	
P3.3.3.7	Preset Frequency 5	P3.3.1.1	P3.3.1.2	Hz	30.00 ⁽¹⁾	128	
P3.3.3.8	Preset Frequency 6	P3.3.1.1	P3.3.1.2	Hz	40.00 ⁽¹⁾	129	
P3.3.3.9	Preset Frequency 7	P3.3.1.1	P3.3.1.2	Hz	50.00 ⁽¹⁾	130	

Index	Parameter	Min	Max	Unit	Default	ID	Description
P3.3.3.10	Preset Frequency Selection 0				DigIN SlotA.4	419	
P3.3.3.11	Preset Frequency Selection 1				DigIN SlotA.5	420	
P3.3.3.12	Preset Frequency Selection 2				DigIN Slot0.1	421	

¹ The selection of the application with parameter P1.2 Application gives the default value. See the default values in [11.27 Default Values of Parameters in the Different Applications](#).

Table 44: Motor Potentiometer Parameters

Index	Parameter	Min	Max	Unit	Default	ID	Description
P3.3.4.1	Motor Potentiometer UP				DigIN Slot0.1	418	OPEN = Not active CLOSED = Active
P3.3.4.2	Motor Potentiometer DOWN				DigIN Slot0.1	417	OPEN = Not active CLOSED = Active
P3.3.4.3	Motor Potentiometer Ramp Time	0.1	500.0	Hz/s	10.0	331	
P3.3.4.4	Motor Potentiometer Reset	0	2		1	367	0 = No reset 1 = Reset if stopped 2 = Reset if powered down

Table 45: Joystick Control Parameters

Index	Parameter	Min	Max	Unit	Default	ID	Description
P3.3.5.1	Joystick Signal Selection	0	6		0	451	0 = Not Used 1 = AI1 (0–100%) 2 = AI2 (0–100%) 3 = AI3 (0–100%) 4 = AI4 (0–100%) 5 = AI5 (0–100%) 6 = AI6 (0–100%)
P3.3.5.2	Joystick Dead Zone	0.0	20.0	%	2.0	384	
P3.3.5.3	Joystick Sleep Zone	0.0	20.0	%	0.0	385	0 = Not used
P3.3.5.4	Joystick Sleep Delay	0.00	300.00	s	0.00	386	0 = Not used

Table 46: Jogging Parameters

Index	Parameter	Min	Max	Unit	Default	ID	Description
P3.3.6.1	Enable DI Jogging	Varies	Varies		DigIN Slot0.1	532	
P3.3.6.2	Jogging Reference 1 Activation	Varies	Varies		DigIN Slot0.1	530	
P3.3.6.3	Jogging Reference 2 Activation	Varies	Varies		DigIN Slot0.1	531	

Index	Parameter	Min	Max	Unit	Default	ID	Description
P3.3.6.4	Jogging Reference 1	-MaxRef	MaxRef	Hz	0.00	1239	
P3.3.6.5	Jogging Reference 2	-MaxRef	MaxRef	Hz	0.00	1240	
P3.3.6.6	Jogging Ramp	0.1	300.0	s	10.0	1257	

6.4 Group 3.4: Ramps and Brakes Setup

Table 47: Ramp 1 Setup

Index	Parameter	Min	Max	Unit	Default	ID	Description
P3.4.1.1	Ramp 1 Shape	0.0	100.0	%	0.0	500	
P3.4.1.2	Acceleration Time 1	0.1	300.0	s	5.0	103	
P3.4.1.3	Deceleration Time 1	0.1	300.0	s	5.0	104	

Table 48: Ramp 2 Setup

Index	Parameter	Min	Max	Unit	Default	ID	Description
P3.4.2.1	Ramp 2 Shape	0.0	100.0	%	0.0	501	
P3.4.2.2	Acceleration Time 2	0.1	300.0	s	10.0	502	
P3.4.2.3	Deceleration Time 2	0.1	300.0	s	10.0	503	
P3.4.2.4	Ramp 2 Selection	Varies	Varies		DigIN Slot0.1	408	0 = OPEN 1 = CLOSED

Table 49: Start Magnetization Parameters

Index	Parameter	Min	Max	Unit	Default	ID	Description
P3.4.3.1	Start Magnetizing Current	0.00	IL	A	IH	517	0 = Disabled
P3.4.3.2	Start Magnetizing Time	0.00	600.00	s	0.00	516	

Table 50: DC Brake Parameters

Index	Parameter	Min	Max	Unit	Default	ID	Description
P3.4.4.1	DC Brake Current	0	IL	A	IH	507	0 = Disabled
P3.4.4.2	DC Braking Time at Stop	0.00	600.00	s	0.00	508	
P3.4.4.3	Frequency to Start DC Braking at Ramp Stop	0.10	10.00	Hz	1.50	515	

Table 51: Flux Braking Parameters

Index	Parameter	Min	Max	Unit	Default	ID	Description
P3.4.5.1	Flux Braking	0	1		0	520	0 = Disabled 1 = Enabled
P3.4.5.2	Flux Braking Current	0	IL	A	IH	519	

6.5 Group 3.5: I/O Configuration

Table 52: Digital Input Settings

Index	Parameter	Min	Max	Unit	Default	ID	Description
P3.5.1.1	Control Signal 1 A				DigIN SlotA.1 ⁽¹⁾	403	
P3.5.1.2	Control Signal 2 A				DigIN SlotA.2 ⁽¹⁾	404	
P3.5.1.3	Control Signal 3 A				DigIN Slot0.1	434	
P3.5.1.4	Control Signal 1 B				DigIN Slot0.1 ⁽¹⁾	423	
P3.5.1.5	Control Signal 2 B				DigIN Slot0.1 ⁽¹⁾	424	
P3.5.1.6	Control Signal 3 B				DigIN Slot0.1	435	
P3.5.1.7	I/O B Control Force				DigIN Slot0.1 ⁽¹⁾	425	CLOSED = Force the control place to I/O B
P3.5.1.8	I/O B Reference Force				DigIN Slot0.1 ⁽¹⁾	343	CLOSED = I/O reference B (P3.3.1.6) gives the frequency reference
P3.5.1.9	Fieldbus Control Force				DigIN Slot0.1 ⁽¹⁾	411	
P3.5.1.10	Keypad Control Force				DigIN Slot0.1 ⁽¹⁾	410	
P3.5.1.11	External Fault Close				DigIN SlotA.3 ⁽¹⁾	405	OPEN = OK CLOSED = External fault
P3.5.1.12	External Fault Open				DigIN Slot0.2	406	OPEN = External fault CLOSED = OK
P3.5.1.13	Fault Reset Close				Varies	414	CLOSED = Resets all active faults
P3.5.1.14	Fault Reset Open				DigIN Slot0.1	213	OPEN = Resets all active faults
P3.5.1.15	Run Enable				DigIN Slot0.2	407	
P3.5.1.16	Run Interlock 1				DigIN Slot0.2	1041	
P3.5.1.17	Run Interlock 2				DigIN Slot0.2	1042	
P3.5.1.18	Motor Preheat ON				DigIN Slot0.1	1044	OPEN = No action

Index	Parameter	Min	Max	Unit	Default	ID	Description
							CLOSED = Uses the DC current of the motor preheat in Stop state. Used when the value of P3.18.1 is 2.
P3.5.1.19	Ramp 2 Selection				DigIN Slot0.1 ⁽¹⁾	408	OPEN = Ramp 1 Shape, Acceleration Time 1, and Deceleration Time 1. CLOSED = Ramp 2 Shape, Acceleration Time 2, and Deceleration Time 2.
P3.5.1.20	Acc/Dec Prohibit				DigIN Slot0.1	415	
P3.5.1.21	Preset Frequency Selection 0				DigIN SlotA.4 ⁽¹⁾	419	
P3.5.1.22	Preset Frequency Selection 1				Varies	420	
P3.5.1.23	Preset Frequency Selection 2				DigIN Slot0.1 ⁽¹⁾	421	
P3.5.1.24	Motor Potentiometer UP				DigIN Slot0.1 ⁽¹⁾	418	OPEN = Not active CLOSED = Active
P3.5.1.25	Motor Potentiometer DOWN				DigIN Slot0.1 ⁽¹⁾	417	OPEN = Not active CLOSED = Active
P3.5.1.26	Quick Stop Activation				Varies	1213	OPEN = Activated
P3.5.1.27	Timer 1				DigIN Slot0.1	447	
P3.5.1.28	Timer 2				DigIN Slot0.1	448	
P3.5.1.29	Timer 3				DigIN Slot0.1	449	
P3.5.1.30	PID1 Setpoint Boost				DigIN Slot0.1	1046	OPEN = No boost CLOSED = Boost
P3.5.1.31	PID1 Select Setpoint				DigIN Slot0.1	1047	OPEN = Setpoint 1 CLOSED = Setpoint 2
P3.5.1.32	External PID Start Signal				DigIN Slot0.2	1049	OPEN = PID2 in stop mode CLOSED = PID2 regulating
P3.5.1.33	External PID Select Setpoint				DigIN Slot0.1	1048	OPEN = Setpoint 1 CLOSED = Setpoint 2
P3.5.1.34	Motor 1 Interlock				DigIN Slot0.1	426	OPEN = Not active CLOSED = Active
P3.5.1.35	Motor 2 Interlock				DigIN Slot0.1	427	OPEN = Not active CLOSED = Active
P3.5.1.36	Motor 3 Interlock				DigIN Slot0.1	428	OPEN = Not active CLOSED = Active

Index	Parameter	Min	Max	Unit	Default	ID	Description
P3.5.1.37	Motor 4 Interlock				DigIN Slot0.1	429	OPEN = Not active CLOSED = Active
P3.5.1.38	Motor 5 Interlock				DigIN Slot0.1	430	OPEN = Not active CLOSED = Active
P3.5.1.39	Motor 6 Interlock				DigIN Slot0.1	486	OPEN = Not active CLOSED = Active
P3.5.1.40	Reset Maintenance Counter				DigIN Slot0.1	490	CLOSED = Reset
P3.5.1.41	Enable DI Jogging				DigIN Slot0.1	532	
P3.5.1.42	Jogging Reference 1 Activation				DigIN Slot0.1	530	
P3.5.1.43	Jogging Reference 2 Activation				DigIN Slot0.1	531	
P3.5.1.44	Mechanical Brake Feedback				DigIN Slot0.1	1210	
P3.5.1.45	Fire Mode Activation OPEN				DigIN Slot0.2	1596	OPEN = Fire Mode active CLOSED = No action
P3.5.1.46	Fire Mode Activation CLOSE				DigIN Slot0.1	1619	OPEN = No action CLOSED = Fire Mode active
P3.5.1.47	Fire Mode Reverse				DigIN Slot0.1	1618	OPEN = Forward CLOSED = Reverse
P3.5.1.48	Auto-cleaning Activation				DigIN Slot0.1	1715	
P3.5.1.49	Parameter Set 1/2 Selection				DigIN Slot0.1	496	OPEN = Parameter set 1 CLOSED = Parameter set 2
P3.5.1.50	User Defined Fault 1 Activation				DigIN Slot0.1	15523	OPEN = No action CLOSED = Fault activated
P3.5.1.51	User Defined Fault 2 Activation				DigIN Slot0.1	15524	OPEN = No action CLOSED = Fault activated
P3.5.1.52	AHF Overtemperature				DigIN Slot0.2	15513	

¹ The selection of the application with parameter P1.2 Application gives the default value. See the default values in [11.27 Default Values of Parameters in the Different Applications](#).

Table 53: Analog Input 1 Settings

Index	Parameter	Min	Max	Unit	Default	ID	Description
P3.5.2.1.1	A11 Signal Selection				AnIN SlotA.1	377	
P3.5.2.1.2	A11 Signal Filter Time	0.00	300.00	s	0.1 ⁽¹⁾	378	

Index	Parameter	Min	Max	Unit	Default	ID	Description
P3.5.2.1.3	AI1 Signal Range	0	1		0 ⁽¹⁾	379	0 = 0...10 V/0...20 mA 1 = 2...10 V/4...20 mA
P3.5.2.1.4	AI1 Custom. Min	-160.00	160.00	%	0.00 ⁽¹⁾	380	
P3.5.2.1.5	AI1 Custom. Max	-160.00	160.00	%	100.00 ⁽¹⁾	381	
P3.5.2.1.6	AI1 Signal Inversion	0	1		0 ⁽¹⁾	387	0 = Normal 1 = Signal inverted

¹ The selection of the application with parameter P1.2 Application gives the default value. See the default values in [11.27 Default Values of Parameters in the Different Applications](#).

Table 54: Analog Input 2 Settings

Index	Parameter	Min	Max	Unit	Default	ID	Description
P3.5.2.2.1	AI2 Signal Selection				AnIN SlotA.2	388	See P3.5.2.1.1.
P3.5.2.2.2	AI2 Signal Filter Time	0.00	300.00	s	0.1 ⁽¹⁾	389	See P3.5.2.1.2.
P3.5.2.2.3	AI2 Signal Range	0	1		1 ⁽¹⁾	390	See P3.5.2.1.3.
P3.5.2.2.4	AI2 Custom. Min	-160.00	160.00	%	0.00 ⁽¹⁾	391	See P3.5.2.1.4.
P3.5.2.2.5	AI2 Custom. Max	-160.00	160.00	%	100.00 ⁽¹⁾	392	See P3.5.2.1.5.
P3.5.2.2.6	AI2 Signal Inversion	0	1		0 ⁽¹⁾	398	See P3.5.2.1.6.

¹ The selection of the application with parameter P1.2 Application gives the default value. See the default values in [11.27 Default Values of Parameters in the Different Applications](#).

Table 55: Analog Input 3 Settings

Index	Parameter	Min	Max	Unit	Default	ID	Description
P3.5.2.3.1	AI3 Signal Selection				AnIN SlotD.1	141	See P3.5.2.1.1.
P3.5.2.3.2	AI3 Signal Filter Time	0.00	300.00	s	0.1	142	See P3.5.2.1.2.
P3.5.2.3.3	AI3 Signal Range	0	1		0	143	See P3.5.2.1.3.
P3.5.2.3.4	AI3 Custom. Min	-160.00	160.00	%	0.00	144	See P3.5.2.1.4.
P3.5.2.3.5	AI3 Custom. Max	-160.00	160.00	%	100.00	145	See P3.5.2.1.5.
P3.5.2.3.6	AI3 Signal Inversion	0	1		0 ⁽¹⁾	151	See P3.5.2.1.6.

¹ The selection of the application with parameter P1.2 Application gives the default value. See the default values in [11.27 Default Values of Parameters in the Different Applications](#).

Table 56: Analog Input 4 Settings

Index	Parameter	Min	Max	Unit	Default	ID	Description
P3.5.2.4.1	AI4 Signal Selection				AnIN SlotD.2	152	See P3.5.2.1.1.
P3.5.2.4.2	AI4 Signal Filter Time	0.00	300.00	s	0.1	153	See P3.5.2.1.2.
P3.5.2.4.3	AI4 Signal Range	0	1		0	154	See P3.5.2.1.3.
P3.5.2.4.4	AI4 Custom. Min	-160.00	160.00	%	0.00	155	See P3.5.2.1.4.
P3.5.2.4.5	AI4 Custom. Max	-160.00	160.00	%	100.00	156	See P3.5.2.1.5.
P3.5.2.4.6	AI4 Signal Inversion	0	1		0	162	See P3.5.2.1.6.

Table 57: Analog Input 5 Settings

Index	Parameter	Min	Max	Unit	Default	ID	Description
P3.5.2.5.1	AI5 Signal Selection				AnIN SlotE.1	188	See P3.5.2.1.1.
P3.5.2.5.2	AI5 Signal Filter Time	0.00	300.00	s	0.1	189	See P3.5.2.1.2.
P3.5.2.5.3	AI5 Signal Range	0	1		0	190	See P3.5.2.1.3.
P3.5.2.5.4	AI5 Custom. Min	-160.00	160.00	%	0.00	191	See P3.5.2.1.4.
P3.5.2.5.5	AI5 Custom. Max	-160.00	160.00	%	100.00	192	See P3.5.2.1.5.
P3.5.2.5.6	AI5 Signal Inversion	0	1		0	198	See P3.5.2.1.6.

Table 58: Analog Input 6 Settings

Index	Parameter	Min	Max	Unit	Default	ID	Description
P3.5.2.6.1	AI6 Signal Selection				AnIN SlotE.2	199	See P3.5.2.1.1.
P3.5.2.6.2	AI6 Signal Filter Time	0.00	300.00	s	0.1	200	See P3.5.2.1.2.
P3.5.2.6.3	AI6 Signal Range	0	1		0	201	See P3.5.2.1.3.
P3.5.2.6.4	AI6 Custom. Min	-160.00	160.00	%	0.00	203	See P3.5.2.1.4.
P3.5.2.6.5	AI6 Custom. Max	-160.00	160.00	%	100.00	204	See P3.5.2.1.5.
P3.5.2.6.6	AI6 Signal Inversion	0	1		0	209	See P3.5.2.1.6.

NOTICE

Shows only the parameters for the outputs on option boards in slots C, D, and E. Make the selections as in RO1 Function (P3.5.3.2.1). This group or these parameters are not visible if there are no digital outputs in slots C, D, or E.

Table 59: Digital Output Settings on Standard I/O Board

Index	Parameter	Min	Max	Unit	De- fault	ID	Description
P3.5.3.2.1	RO1 Func- tion	0	62		Varies	11001	0 = None 1 = Ready 2 = Run 3 = General fault 4 = General fault inverted 5 = General alarm 6 = Reversed 7 = At speed 8 = Thermistor fault 9 = Motor regulator active 10 = Start signal active 11 = Keypad control active 12 = I/O B control activated 13 = Limit supervision 1 14 = Limit supervision 2 15 = Fire Mode active 16 = Jogging activated 17 = Preset speed active 18 = Quick stop activated 19 = PID in Sleep mode 20 = PID soft fill active 21 = PID feedback supervision (limits) 22 = Ext. PID supervision (limits) 23 = Input press. alarm/fault 24 = Frost prot. alarm/fault 25 = Motor 1 control 26 = Motor 2 control 27 = Motor 3 control 28 = Motor 4 control 29 = Motor 5 control 30 = Motor 6 control 31 = Time Channel 1 32 = Time Channel 2 33 = Time Channel 3 34 = FB ControlWord B13 35 = FB ControlWord B14 36 = FB ControlWord B15 37 = FB Process- Data1.B0 38 = FB Process- Data1.B1 39 = FB Process- Data1.B2 40 = Maintenance alarm 41 = Maintenance fault 42 = Mechanical brake (Open brake command) 43 = Mech. brake inverted 44 = Block Out.1 45 = Block Out.2 46 = Block Out.3 47 = Block Out.4

Index	Parameter	Min	Max	Unit	De- fault	ID	Description
							48 = Block Out.5 49 = Block Out.6 50 = Block Out.7 51 = Block Out.8 52 = Block Out.9 53 = Block Out.10 54 = Jockey pump control 55 = Priming pump control 56 = Auto-cleaning active 57 = Motor Switch Open 58 = TEST (Always Closed) 59 = Motor preheat active 60 = AHF Cap Disconnect 61 = AHF Cap Disconnect Inv 62 = Run Indication
P3.5.3.2.2	RO1 ON Delay	0.00	320.00	s	0.00	11002	
P3.5.3.2.3	RO1 OFF Delay	0.00	320.00	s	0.00	11003	
P3.5.3.2.4	RO2 Func- tion	0	56		Varies	11004	See P3.5.3.2.1.
P3.5.3.2.5	RO2 ON Delay	0.00	320.00	s	0.00	11005	See P3.5.3.2.2.
P3.5.3.2.6	RO2 OFF Delay	0.00	320.00	s	0.00	11006	See P3.5.3.2.3.
P3.5.3.2.7	RO3 Func- tion	0	56		Varies	11007	See P3.5.3.2.1. Not visible if only 2 output relays are installed.
P3.5.3.2.8	RO3 ON Delay	0.00	320.00	s	0.00	11008	See P3.5.3.2.2. Not visible if only 2 output relays are installed.
P3.5.3.2.9	RO3 OFF Delay	0.00	320.00	s	0.00	11009	See P3.5.3.2.3. Not visible if only 2 output relays are installed.

NOTICE

Shows only the parameters for the outputs on option boards in slots C, D, and E. Make the selections as in Basic AO1 Function (P3.5.4.1.1). This group or these parameters are not visible if there are no digital outputs in slots C, D, or E.

Table 60: Analog Output Settings on Standard I/O board

Index	Parameter	Min	Max	Unit	Default	ID	Description
P3.5.4.1.1	AO1 function	0	31		2 ⁽¹⁾	10050	0 = TEST 0% (Not used) 1 = TEST 100% 2 = Output freq (0 - fmax) 3 = Freq reference (0 - fmax)

Index	Parameter	Min	Max	Unit	Default	ID	Description
							4 = Motor speed (0 - Motor nominal speed) 5 = Output current (0 - InMotor) 6 = Motor torque (0 - TnMotor) 7 = Motor power (0 - PnMotor) 8 = Motor voltage (0 - UnMotor) 9 = DC link voltage (0-1000 V) 10 = PID Setpoint (0-100%) 11 = PID Feedback (0-100%) 12 = PID1 output (0-100%) 13 = Ext.PID output (0-100%) 14 = ProcessDataIn1 (0-100%) 15 = ProcessDataIn2 (0-100%) 16 = ProcessDataIn3 (0-100%)
P3.5.4.1.1	AO1 function	0	31		2 ⁽¹⁾	10050	17 = ProcessDataIn4 (0-100%) 18 = ProcessDataIn5 (0-100%) 19 = ProcessDataIn6 (0-100%) 20 = ProcessDataIn7 (0-100%) 21 = ProcessDataIn8 (0-100%) 22 = Block Out.1 (0-100%) 23 = Block Out.2 (0-100%) 24 = Block Out.3 (0-100%) 25 = Block Out.4 (0-100%) 26 = Block Out.5 (0-100%) 27 = Block Out.6 (0-100%) 28 = Block Out.7 (0-100%) 29 = Block Out.8 (0-100%) 30 = Block Out.9 (0-100%) 31 = Block Out.10 (0-100%)
P3.5.4.1.2	AO1 Filter Time	0.0	300.0	s	1.0 ⁽¹⁾	10051	0 = No filtering
P3.5.4.1.3	AO1 minimum	0	1		0 ⁽¹⁾	10052	
P3.5.4.1.4	AO1 minimum scale	Varies	Varies	Varies	0.0 ⁽¹⁾	10053	0 = 0 mA/0 V 1 = 4 mA/2 V
P3.5.4.1.5	AO1 maximum scale	Varies	Varies	Varies	0.0 ⁽¹⁾	10054	

¹ The selection of the application with parameter P1.2 Application gives the default value. See the default values in [11.27 Default Values of Parameters in the Different Applications](#).

6.6 Group 3.6: Fieldbus Data

Table 61: Fieldbus Data Parameters

Index	Parameter	Min	Max	Unit	Default	ID	Description
P3.6.1	Fieldbus Data Out 1 Selection	0	35000		1	852	
P3.6.2	Fieldbus Data Out 2 Selection	0	35000		2	853	

Index	Parameter	Min	Max	Unit	Default	ID	Description
P3.6.3	Fieldbus Data Out 3 Selection	0	35000		3	854	
P3.6.4	Fieldbus Data Out 4 Selection	0	35000		4	855	
P3.6.5	Fieldbus Data Out 5 Selection	0	35000		5	856	
P3.6.6	Fieldbus Data Out 6 Selection	0	35000		6	857	
P3.6.7	Fieldbus Data Out 7 Selection	0	35000		7	858	
P3.6.8	Fieldbus Data Out 8 Selection	0	35000		37	859	
P3.6.9	Fieldbus Data Out 9 Selection	0	35000		0	890	
P3.6.10	Fieldbus Data Out 10 Selection	0	35000		0	891	
P3.6.11	Fieldbus Data Out 11 Selection	0	35000		0	892	
P3.6.12	Fieldbus Data Out 12 Selection	0	35000		0	893	
P3.6.13	Fieldbus Data Out 13 Selection	0	35000		0	894	
P3.6.14	Fieldbus Data Out 14 Selection	0	35000		0	895	
P3.6.15	Fieldbus Data Out 15 Selection	0	35000		0	896	
P3.6.16	Fieldbus Data Out 16 Selection	0	35000		0	897	
P3.6.17	FB Sign of Actual	0	2		0	888	0 = Positive 1 = Actual direction 2 = Follow reference

Table 62: The Default Values for Process Data Out in Fieldbus

Data	Default Value	Scale
Process Data Out 1	Output frequency	0.01 Hz
Process Data Out 2	Motor speed	1 RPM
Process Data Out 3	Motor current	0.1 A
Process Data Out 4	Motor torque	0.1%
Process Data Out 5	Motor power	0.1%
Process Data Out 6	Motor voltage	0.1 V
Process Data Out 7	DC link voltage	1 V
Process Data Out 8	Last active fault code	1

Example

The value 2500 for output frequency equals 25.00 Hz, because the scale is 0.01. All the monitoring values in the Monitor menu (chapter [5.1 Uses of the Monitor Menu](#)) are given the scale value.

6.7 Group 3.7: Prohibit Frequencies

Table 63: Prohibit Frequencies Parameters

Index	Parameter	Min	Max	Unit	Default	ID	Description
P3.7.1	Prohibit Frequency Range 1 Low Limit	-1.00	320.00	Hz	0.00	509	0 = Not used
P3.7.2	Prohibit Frequency Range 1 High Limit	0.00	320.00	Hz	0.00	510	0 = Not used
P3.7.3	Prohibit Frequency Range 2 Low Limit	0.00	320.00	Hz	0.00	511	0 = Not used
P3.7.4	Prohibit Frequency Range 2 High Limit	0.00	320.00	Hz	0.00	512	0 = Not used
P3.7.5	Prohibit Frequency Range 3 Low Limit	0.00	320.00	Hz	0.00	513	0 = Not used
P3.7.6	Prohibit Frequency Range 3 High Limit	0.00	320.00	Hz	0.00	514	0 = Not used
P3.7.7	Ramp Time Factor	0.1	10.0	Times	1.0	518	

6.8 Group 3.8 Supervisions

Table 64: Supervision Settings

Index	Parameter	Min	Max	Unit	Default	ID	Description
P3.8.1	Supervision #1 Item Selection	0	17		0	1431	0 = Output frequency 1 = Frequency reference 2 = Motor current 3 = Motor torque 4 = Motor power 5 = DC link voltage 6 = Analog input 1 7 = Analog input 2 8 = Analog input 3 9 = Analog input 4 10 = Analog input 5 11 = Analog input 6 12 = Temperature input 1 13 = Temperature input 2 14 = Temperature input 3 15 = Temperature input 4 16 = Temperature input 5 17 = Temperature input 6
P3.8.2	Supervision #1 Mode	0	2		0	1432	0 = Not used 1 = Low limit supervision 2 = High limit supervision
P3.8.3	Supervision #1 Limit	-50.00	50.00	Varies	25.00	1433	
P3.8.4	Supervision #1 Limit Hysteresis	0.00	50.00	Varies	5.00	1434	
P3.8.5	Supervision #2 Item Selection	0	17		1	1435	See P3.8.1

Index	Parameter	Min	Max	Unit	Default	ID	Description
P3.8.6	Supervision #2 Mode	0	2		0	1436	See P3.8.2
P3.8.7	Supervision #2 Limit	-50.00	50.00	Varies	40.00	1437	
P3.8.8	Supervision #2 Limit Hysteresis	0.00	50.00	Varies	5.00	1438	

6.9 Group 3.9: Protections

Table 65: General Protection Settings

Index	Parameter	Min	Max	Unit	Default	ID	Description
P3.9.1.2	Response to External Fault	0	3		2	701	0 = No action 1 = Alarm 2 = Fault (Stop according to stop function) 3 = Fault (Stop by coasting)
P3.9.1.3	Input Phase Fault	0	1		0	730	0 = 3-phase support 1 = 1-phase support
P3.9.1.4	Undervoltage Fault	0	1		0	727	0 = Fault stored in history 1 = Fault not stored in history
P3.9.1.5	Response to Output Phase Fault	0	3		2	702	See P3.9.1.2.
P3.9.1.6	Response to Fieldbus Communication Fault	0	5		3	733	0 = No action 1 = Alarm 2 = Alarm + preset fault frequency (P3.9.1.13) 3 = Fault (Stop according to stop function) 4 = Fault (Stop by coasting)
P3.9.1.7	Slot Communication Fault	0	3		2	734	See P3.9.1.2.
P3.9.1.8	Thermistor Fault	0	3		0	732	See P3.9.1.2.
P3.9.1.9	PID Soft Fill Fault	0	3		2	748	See P3.9.1.2.
P3.9.1.10	Response to PID Supervision Fault	0	3		2	749	See P3.9.1.2.
P3.9.1.11	Response to External PID Supervision Fault	0	3		2	757	0 = No action 1 = Alarm 2 = Fault 3 = Fault, Coast
P3.9.1.12	Earth Fault	0	3		3	703	This parameter is available only in enclosure sizes MR7, MR8, MR9, MR10, MR11, and MR12, and also MR6 600 V and 690 V.

Index	Parameter	Min	Max	Unit	Default	ID	Description
P3.9.1.13	Preset Alarm Frequency	P3.3.1.1	P3.3.1.2	Hz	25.00	183	
P3.9.1.14	Response to Safe Torque Off (STO) Fault	0	2		2	775	0 = No action 1 = Alarm 2 = Fault (Stop by coasting)
P3.9.1.15	Startup Prevented Fault	0	1		0	15593	0 = Fault 1 = No action
P3.9.1.16	Response to Fieldbus Redundant Control Switch-over	0	2		1	750	0 = No action 1 = Alarm 2 = Alarm + reset
P3.9.1.17	Fieldbus Communication Fault Force Delay	0.00	320.00	s	0.00	751	
P3.9.1.18	Fieldbus Communication Fault Clear Delay	0.00	320.00	s	0.00	752	
P3.9.1.19	Unbalance Current Alarm	0	1		1	753	0 = No action 1 = Alarm

Table 66: Motor Thermal Protection Settings

Index	Parameter	Min	Max	Unit	Default	ID	Description
P3.9.2.1	Motor Thermal Protection	0	3		2	704	0 = No action 1 = Alarm 2 = Fault (Stop by stop mode) 3 = Fault (Stop by coasting)
P3.9.2.2	Ambient Temperature	-20.0	100.0	°C	40.0	705	
P3.9.2.3	Zero Speed Cooling Factor	5.0	150.0	%	Varies	706	
P3.9.2.4	Motor Thermal Time Constant	1	200	min	Varies	707	
P3.9.2.5	Motor Thermal Loadability	10	150	%	100	708	
P3.9.2.6	Motor Thermal Memory Adjust	0	100	%	33	778	

Table 67: Motor Stall Protection Settings

Index	Parameter	Min	Max	Unit	Default	ID	Description
P3.9.3.1	Motor Stall Fault	0	3		0	709	0 = No action 1 = Alarm 2 = Fault (Stop according to stop mode)

Index	Parameter	Min	Max	Unit	Default	ID	Description
							3 = Fault (Stop by coasting)
P3.9.3.2	Stall Current	0.00	Varies	A	Varies	710	
P3.9.3.3	Stall Time Limit	1.00	120.00	s	15.00	711	
P3.9.3.4	Stall Frequency Limit	1.00	P3.3.1.2	Hz	25.00	712	

Table 68: Motor Underload Protection Settings

Index	Parameter	Min	Max	Unit	Default	ID	Description
P3.9.4.1	Underload Fault	0	3		0	713	0 = No action 1 = Alarm 2 = Fault (Stop according to stop mode) 3 = Fault (Stop by coasting)
P3.9.4.2	Underload Protection: Field Weakening Area Load	10.0	150.0	%	50.0	714	
P3.9.4.3	Underload Protection: Zero Frequency Load	5.0	150.0	%	10.0	715	
P3.9.4.4	Underload Protection: Time Limit	2.00	600.00	s	20.00	716	

Table 69: Quick Stop Settings

Index	Parameter	Min	Max	Unit	Default	ID	Description
P3.9.5.1	Quick Stop Mode	0	2		Varies	1276	0 = Coasting 1 = Quick stop deceleration time 2 = Stop according to Stop function (P3.2.5)
P3.9.5.2	Quick Stop Activation	Varies	Varies		DigIN Slot0.2	1213	OPEN = Activated
P3.9.5.3	Quick Stop Deceleration Time	0.1	300.0	s	Varies	1256	
P3.9.5.4	Response to Quick Stop Fault	0	2		Varies	744	0 = No action 1 = Alarm 2 = Fault (Stop according to Quick stop mode)

Table 70: Temperature Input Fault 1 Settings

Index	Parameter	Min	Max	Unit	Default	ID	Description
P3.9.6.1 ⁽¹⁾	Temperature Signal 1	0	63		0	739	B0 = Temperature Signal 1 B1 = Temperature Signal 2 B2 = Temperature Signal 3 B3 = Temperature Signal 4 B4 = Temperature Signal 5

Index	Parameter	Min	Max	Unit	Default	ID	Description
							B5 = Temperature Signal 6
P3.9.6.2 ⁽¹⁾	Alarm Limit 1	-30.0	200.0	°C	130.0	741	
P3.9.6.3 ⁽¹⁾	Fault Limit 1	-30.0	200.0	°C	155.0	742	
P3.9.6.4 ⁽¹⁾	Fault Limit Response 1	0	3		2	740	0 = No response 1 = Alarm 2 = Fault (Stop according to stop mode) 3 = Fault (Stop by coasting)

¹ Temperature input settings are only available if a B8 or BH option board is installed.

Table 71: Temperature Input Fault 2 Settings

Index	Parameter	Min	Max	Unit	Default	ID	Description
P3.9.6.5 ⁽¹⁾	Temperature Signal 2	0	63		0	763	B0 = Temperature Signal 1 B1 = Temperature Signal 2 B2 = Temperature Signal 3 B3 = Temperature Signal 4 B4 = Temperature Signal 5 B5 = Temperature Signal 6
P3.9.6.6 ⁽¹⁾	Alarm Limit 2	-30.0	200.0	°C	130.0	764	
P3.9.6.7 ⁽¹⁾	Fault Limit 2	-30.0	200.0	°C	155.0	765	
P3.9.6.8 ⁽¹⁾	Fault Limit Response 2	0	3		2	766	0 = No response 1 = Alarm 2 = Fault (Stop according to stop mode) 3 = Fault (Stop by coasting)

¹ Temperature input settings are only available if a B8 or BH option board is installed.

Table 72: AI Low Protection Settings

Index	Parameter	Min	Max	Unit	Default	ID	Description
P3.9.8.1	Analog Input Low Protection	0	2			767	0 = No protection 1 = Protection enabled in Run state 2 = Protection enabled in Run and Stop state
P3.9.8.2	Analog Input Low Fault	0	5		0	700	0 = No action 1 = Alarm 2 = Alarm + preset fault frequency (P3.9.1.13) 3 = Alarm + previous frequency reference 4 = Fault (Stop according to stop mode) 5 = Fault (Stop by coasting)

Table 73: User Defined Fault 1

Index	Parameter	Min	Max	Unit	Default	ID	Description
P3.9.9.1	User Defined Fault 1	-	-		DigIN Slot0.1	15523	OPEN = No operation CLOSED = Fault activated
P3.9.9.2	Response to User Defined Fault 1	-	-		Fault, Coast	15525	

Table 74: User Defined Fault 2

Index	Parameter	Min	Max	Unit	Default	ID	Description
P3.9.10.1	User Defined Fault 2	-	-		DigIN Slot0.1	15524	OPEN = No operation CLOSED = Fault activated
P3.9.10.2	Response to User Defined Fault 2	-	-		Fault, Coast	15526	

6.10 Group 3.10: Automatic Reset

Table 75: Automatic Reset Settings

Index	Parameter	Min	Max	Unit	Default	ID	Description
P3.10.1	Automatic Reset	0	1		0	731	0 = Disabled 1 = Enabled
P3.10.2	Restart Function	0	1		1	719	0 = Flying start 1 = According to P3.2.4.
P3.10.3	Wait Time	0.10	10000.00	s	0.50	717	
P3.10.4	Trial Time	0.00	10000.00	s	60.00	718	
P3.10.5	Number of Trials	1	10		4	759	
P3.10.6	Autoreset: Undervoltage	0	1		1	720	0 = No 1 = Yes
P3.10.7	Autoreset: Overvoltage	0	1		1	721	0 = No 1 = Yes
P3.10.8	Autoreset: Overcurrent	0	1		1	722	0 = No 1 = Yes
P3.10.9	Autoreset: AI Low	0	1		1	723	0 = No 1 = Yes
P3.10.10	Autoreset: Unit Overtemperature	0	1		1	724	0 = No 1 = Yes
P3.10.11	Autoreset: Motor Overtemperature	0	1		1	725	0 = No 1 = Yes
P3.10.12	Autoreset: External Fault	0	1		0	726	0 = No

Index	Parameter	Min	Max	Unit	Default	ID	Description
							1 = Yes
P3.10.13	Autoreset: Underload Fault	0	1		0	738	0 = No 1 = Yes
P3.10.14	Autoreset: PID Supervision Fault	0	1		0	776	0 = No 1 = Yes
P3.10.15	Autoreset: Ext PID Supervision Fault	0	1		0	777	0 = No 1 = Yes
P3.10.16	Fault Simulation	0	65535		0	1569	

6.11 Group 3.11: Application Settings

Table 76: Application Settings

Index	Parameter	Min	Max	Unit	Default	ID	Description
P3.11.1	Password	0	9999		0	1806	
P3.11.2	C/F Selection	0	1		0 ⁽¹⁾	1197	0 = Celsius 1 = Fahrenheit
P3.11.3	kW/hp Selection	0	1		0 ⁽¹⁾	1198	0 = kW 1 = hp
P3.11.4	Multimonitor View	0	2		1	1196	0 = 2x2 sections 1 = 3x2 sections 2 = 3x3 sections
P3.11.5	FUNCT Button Configuration	0	15		15	1195	B0 = Local/Remote B1 = Control Page B2 = Change Direction B3 = Quick Edit
P3.11.6	Set ParamLock	0	9999		0	1807	
P3.11.7	ParamLock Key	0	9999		0	1808	

¹ The default value in the US is 1.

6.12 Group 3.12: Timer Functions

Table 77: Interval 1

Index	Parameter	Min	Max	Unit	Default	ID	Description
P3.12.1.1	ON Time	00:00:00	23:59:59	hh:mm:ss	00:00:00	1464	
P3.12.1.2	OFF Time	00:00:00	23:59:59	hh:mm:ss	00:00:00	1465	
P3.12.1.3	Days					1466	B0 = Sunday

Index	Parameter	Min	Max	Unit	Default	ID	Description
							B1 = Monday B2 = Tuesday B3 = Wednesday B4 = Thursday B5 = Friday B6 = Saturday
P3.12.1.4	Assign to Channel					1468	B0 = Time channel 1 B1 = Time channel 2 B2 = Time channel 3

Table 78: Interval 2

Index	Parameter	Min	Max	Unit	Default	ID	Description
P3.12.2.1	ON Time	00:00:00	23:59:59	hh:mm:ss	00:00:00	1469	See Interval 1.
P3.12.2.2	OFF Time	00:00:00	23:59:59	hh:mm:ss	00:00:00	1470	See Interval 1.
P3.12.2.3	Days					1471	See Interval 1.
P3.12.2.4	Assign to Channel					1473	See Interval 1.

Table 79: Interval 3

Index	Parameter	Min	Max	Unit	Default	ID	Description
P3.12.3.1	ON Time	00:00:00	23:59:59	hh:mm:ss	00:00:00	1474	See Interval 1.
P3.12.3.2	OFF Time	00:00:00	23:59:59	hh:mm:ss	00:00:00	1475	See Interval 1.
P3.12.3.3	Days					1476	See Interval 1.
P3.12.3.4	Assign to Channel					1478	See Interval 1.

Table 80: Interval 4

Index	Parameter	Min	Max	Unit	Default	ID	Description
P3.12.4.1	ON Time	00:00:00	23:59:59	hh:mm:ss	00:00:00	1479	See Interval 1.
P3.12.4.2	OFF Time	00:00:00	23:59:59	hh:mm:ss	00:00:00	1480	See Interval 1.
P3.12.4.3	Days					1481	See Interval 1.
P3.12.4.4	Assign to Channel					1483	See Interval 1.

Table 81: Interval 5

Index	Parameter	Min	Max	Unit	Default	ID	Description
P3.12.5.1	ON Time	00:00:00	23:59:59	hh:mm:ss	00:00:00	1484	See Interval 1.
P3.12.5.2	OFF Time	00:00:00	23:59:59	hh:mm:ss	00:00:00	1485	See Interval 1.
P3.12.5.3	Days					1486	See Interval 1.
P3.12.5.4	Assign to Channel					1488	See Interval 1.

Table 82: Timer 1

Index	Parameter	Min	Max	Unit	Default	ID	Description
P3.12.6.1	Duration	0	72000	s	0	1489	
P3.12.6.2	Timer 1				DigINSlot 0.1	447	
P3.12.6.3	Assign to Channel					1490	B0 = Time channel 1 B1 = Time channel 2 B2 = Time channel 3

Table 83: Timer 2

Index	Parameter	Min	Max	Unit	Default	ID	Description
P3.12.7.1	Duration	0	72000	s	0	1491	See Timer 1.
P3.12.7.2	Timer 2				DigINSlot 0.1	448	See Timer 1.
P3.12.7.3	Assign to Channel					1492	See Timer 1.

Table 84: Timer 3

Index	Parameter	Min	Max	Unit	Default	ID	Description
P3.12.8.1	Duration	0	72000	s	0	1493	See Timer 1.
P3.12.8.2	Timer 3				DigINSlot 0.1	449	See Timer 1.
P3.12.8.3	Assign to Channel					1494	See Timer 1.

6.13 Group 3.13: PID Controller

Table 85: PID Controller Basic Settings

Index	Parameter	Min	Max	Unit	Default	ID	Description
P3.13.1.1	PID Gain	0.00	1000.00	%	100.00	118	
P3.13.1.2	PID Integration Time	0.00	600.00	s	1.00	119	
P3.13.1.3	PID Derivation Time	0.00	100.00	s	0.00	132	

Index	Parameter	Min	Max	Unit	Default	ID	Description
P3.13.1.4	Process Unit Selection	1	38		1	1036	
P3.13.1.5	Process Unit Min	Varies	Varies	Varies	0	1033	
P3.13.1.6	Process Unit Max	Varies	Varies	Varies	100	1034	
P3.13.1.7	Process Unit Decimals	0	4		2	1035	
P3.13.1.8	Error Inversion	0	1		0	340	0 = Normal (Feedback < Setpoint -> Increase PID output) 1 = Inverted (Feedback < Setpoint -> Decrease PID output)
P3.13.1.9	Dead Band	Varies	Varies	Varies	0	1056	
P3.13.1.10	Dead Band Delay	0.00	320.00	s	0.00	1057	

Table 86: Setpoint Settings

Index	Parameter	Min	Max	Unit	Default	ID	Description
P3.13.2.1	Keypad setpoint 1	Varies	Varies	Varies	0	167	
P3.13.2.2	Keypad setpoint 2	Varies	Varies	Varies	0	168	
P3.13.2.3	Setpoint ramp time	0.00	300.0	s	0.00	1068	
P3.13.2.4	PID setpoint boost activation	Varies	Varies		DigIN Slot0.1	1046	OPEN = No boost CLOSED = Boost
P3.13.2.5	PID select setpoint	Varies	Varies		DigIN Slot0.1	1047	OPEN = Setpoint 1 CLOSED = Setpoint 2
P3.13.2.6	Setpoint source 1 selection	0	32		3 ⁽¹⁾	332	0 = Not used 1 = Keypad setpoint 1 2 = Keypad setpoint 2 3 = AI1 4 = AI2 5 = AI3 6 = AI4 7 = AI5 8 = AI6 9 = ProcessDataIn1 10 = ProcessDataIn2 11 = ProcessDataIn3 12 = ProcessDataIn4 13 = ProcessDataIn5 14 = ProcessDataIn6 15 = ProcessDataIn7 16 = ProcessDataIn8 17 = Temperature input 1 18 = Temperature input 2

Index	Parameter	Min	Max	Unit	Default	ID	Description
							19 = Temperature input 3 20 = Temperature input 4 21 = Temperature input 5 22 = Temperature input 6 23 = Block Out.1 24 = Block Out.2 25 = Block Out.3 26 = Block Out.4 27 = Block Out.5 28 = Block Out.6 29 = Block Out.7 30 = Block Out.8 31 = Block Out.9 32 = Block Out.10
P3.13.2.7	Setpoint 1 minimum	-200.00	200.00	%	0.00	1069	
P3.13.2.8	Setpoint 1 maximum	-200.00	200.00	%	100.00	1070	
P3.13.2.9	Setpoint 1 boost	-2.0	2.0	x	1.0	1071	
P3.13.2.10	Setpoint source 2 selection	0	22		2	431	See P3.13.2.6.
P3.13.2.11	Setpoint 2 minimum	-200.00	200.00	%	0.00	1073	See P3.13.2.7.
P3.13.2.12	Setpoint 2 maximum	-200.00	200.00	%	100.00	1074	See P3.13.2.8.
P3.13.2.13	Setpoint 2 boost	-2.0	2.0	x	1.0	1078	See P3.13.2.9.

¹ The selection of the application with parameter P1.2 Application gives the default value. See the default values in [11.27 Default Values of Parameters in the Different Applications](#).

Table 87: Feedback Settings

Index	Parameter	Min	Max	Unit	Default	ID	Description
P3.13.3.1	Feedback Function	1	9		1 ⁽¹⁾	333	1 = Only Source1 in use 2 = SQRT(Source1); (Flow=Constant x SQRT(Pressure)) 3 = SQRT(Source1- Source 2) 4 = SQRT(Source 1) + SQRT (Source 2) 5 = Source 1 + Source 2 6 = Source 1 - Source 2 7 = MIN (Source 1, Source 2) 8 = MAX (Source 1, Source 2) 9 = MEAN (Source 1, Source 2)
P3.13.3.2	Feedback Function Gain	-2100.0	2100.0	%	100.0	1058	
P3.13.3.3	Feedback 1 Source Selection	0	30		2 ⁽¹⁾	334	0 = Not used 1 = AI1 2 = AI2 3 = AI3 4 = AI4

Index	Parameter	Min	Max	Unit	Default	ID	Description
							5 = AI5 6 = AI6 7 = ProcessDataIn1 8 = ProcessDataIn2 9 = ProcessDataIn3 10 = ProcessDataIn4 11 = ProcessDataIn5 12 = ProcessDataIn6 13 = ProcessDataIn7 14 = ProcessDataIn8 15 = Temperature input 1 16 = Temperature input 2 17 = Temperature input 3 18 = Temperature input 4 19 = Temperature input 5 20 = Temperature input 6 21 = Block Out.1 22 = Block Out.2 23 = Block Out.3 24 = Block Out.4 25 = Block Out.5 26 = Block Out.6 27 = Block Out.7 28 = Block Out.8 29 = Block Out.9 30 = Block Out.10
P3.13.3.4	Feedback 1 Minimum	-200.00	200.00	%	0.00	336	
P3.13.3.5	Feedback 1 Maximum	-200.00	200.00	%	100.00	337	
P3.13.3.6	Feedback 2 Source Selection	0	20		0	335	See P3.13.3.3.
P3.13.3.7	Feedback 2 Minimum	-200.00	200.00	%	0.00	338	See P3.13.3.4.
P3.13.3.8	Feedback 2 Maximum	-200.00	200.00	%	100.00	339	See P3.13.3.5.

¹ The selection of the application with parameter P1.2 Application gives the default value. See the default values in [11.27 Default Values of Parameters in the Different Applications](#).

Table 88: Feedforward Settings

Index	Parameter	Min	Max	Unit	Default	ID	Description
P3.13.4.1	Feedforward Function	1	9		1	1059	See P3.13.3.1.
P3.13.4.2	Feedforward Function Gain	-1000	1000	%	100.0	1060	See P3.13.3.2.
P3.13.4.3	Feedforward 1 Source Selection	0	25		0	1061	See P3.13.3.3.

Index	Parameter	Min	Max	Unit	Default	ID	Description
P3.13.4.4	Feedforward 1 Minimum	-200.00	200.00	%	0.00	1062	See P3.13.3.4.
P3.13.4.5	Feedforward 1 Maximum	-200.00	200.00	%	100.00	1063	See P3.13.3.5.
P3.13.4.6	Feedforward 2 Source Selection	0	25		0	1064	See P3.13.3.6.
P3.13.4.7	Feedforward 2 Min	-200.00	200.00	%	0.00	1065	See P3.13.3.7.
P3.13.4.8	Feedforward 2 Max	-200.00	200.00	%	100.00	1066	See P3.13.3.8.

Table 89: Sleep Function Settings

Index	Parameter	Min	Max	Unit	Default	ID	Description
P3.13.5.1	SP1 Sleep Frequency	0.00	320.00	Hz	0.00	1016	
P3.13.5.2	SP1 Sleep Delay	0	300	s	0	1017	
P3.13.5.3	SP1 Wake-up Level			Varies	0.0000	1018	
P3.13.5.4	SP1 Wake-up Mode	0	1		0	1019	0 = Absolute level 1 = Relative setpoint
P3.13.5.5	SP2 Sleep Frequency	0.00	320.00	Hz	0.00	1075	See P3.13.5.1.
P3.13.5.6	SP2 Sleep Delay	0	3000	s	0	1076	See P3.13.5.2.
P3.13.5.7	SP2 Wake-up Level			Varies	0.0000	1077	See P3.13.5.3.
P3.13.5.8	SP2 Wake-up Mode	0	1		0	1020	See P3.13.5.4.

Table 90: Feedback Supervision Parameters

Index	Parameter	Min	Max	Unit	Default	ID	Description
P3.13.6.1	Enable Feedback Supervision	0	1		0	735	0 = Disabled 1 = Enabled
P3.13.6.2	Upper Limit	Varies	Varies	Varies	Varies	736	
P3.13.6.3	Lower Limit	Varies	Varies	Varies	Varies	758	
P3.13.6.4	Delay	0	30000	s	0	737	
P3.13.6.5	Response to PID Supervision Fault	0	3		2	749	0 = No action 1 = Alarm 2 = Fault (Stop according to stop mode) 3 = Fault (Stop by coasting)

Table 91: Pressure Loss Compensation Parameters

Index	Parameter	Min	Max	Unit	Default	ID	Description
P3.13.7.1	Enable Setpoint 1	0	1		0	1189	0 = Disabled 1 = Enabled
P3.13.7.2	Setpoint 1 Max Compensation	Varies	Varies	Varies	Varies	1190	
P3.13.7.3	Enable Setpoint 2	0	1		0	1191	See P3.13.7.1.
P3.13.7.4	Setpoint 2 Max Compensation	Varies	Varies	Varies	Varies	1192	See P3.13.7.2.

Table 92: Soft Fill Settings

Index	Parameter	Min	Max	Unit	Default	ID	Description
P3.13.8.1	Enable Soft Fill	0	1		0	1094	0 = Disabled 1 = Enabled
P3.13.8.2	Soft Fill Frequency	0.00	50.00	Hz	0.00	1055	
P3.13.8.3	Soft Fill Level	Varies	Varies	Varies	0.0000	1095	
P3.13.8.4	Soft Fill Timeout	0	30000	s	0	1096	0 = No timeout
P3.13.8.5	PID Soft Fill Timeout Response	0	3		2	748	0 = No action 1 = Alarm 2 = Fault (Stop according to stop mode) 3 = Fault (Stop by coasting)

Table 93: Input Pressure Supervision Parameters

Index	Parameter	Min	Max	Unit	Default	ID	Description
P3.13.9.1	Enable Supervision	0	1		0	1685	0 = Disabled 1 = Enabled
P3.13.9.2	Supervision Signal	0	23		0	1686	0 = Analog input 1 1 = Analog input 2 2 = Analog input 3 3 = Analog input 4 4 = Analog input 5 5 = Analog input 6 6 = ProcessDataIn1 (0–100%) 7 = ProcessDataIn2 (0–100%) 8 = ProcessDataIn3 (0–100%) 9 = ProcessDataIn4 (0–100%) 10 = ProcessDataIn5 (0–100%) 11 = ProcessDataIn6 (0–100%) 12 = ProcessDataIn7 (0–100%) 13 = ProcessDataIn8 (0–100%) 14 = Block Out.1 15 = Block Out.2 16 = Block Out.3

Index	Parameter	Min	Max	Unit	Default	ID	Description
							17 = Block Out.4 18 = Block Out.5 19 = Block Out.6 20 = Block Out.7 21 = Block Out.8 22 = Block Out.9 23 = Block Out.10
P3.13.9.3	Supervision Unit Selection	0	8	Varies	2	1687	
P3.13.9.4	Supervision Unit Decimals	0	4		2	1688	
P3.13.9.5	Supervision Unit Minimum Value	Varies	Varies	Varies	Varies	1689	
P3.13.9.6	Supervision Unit Maximum Value	Varies	Varies	Varies	Varies	1690	
P3.13.9.7	Supervision Alarm Level	Varies	Varies	Varies	Varies	1691	
P3.13.9.8	Supervision Fault Level	Varies	Varies	Varies	Varies	1692	
P3.13.9.9	Supervision Fault Delay	0.00	60.00	s	5.00	1693	
P3.13.9.10	PID Setpoint Reduction	0.0	100.0	%	10.0	1694	
V3.13.9.11	Input Pressure	Varies	Varies	Varies	Varies	1695	This monitoring value shows the actual value of the pump input pressure.

Table 94: Frost Protection Parameters

Index	Parameter	Min	Max	Unit	Default	ID	Description
P3.13.10.1	Frost Protection	0	1		0	1704	0 = Disabled 1 = Enabled
P3.13.10.2	Temperature Signal	0	29		6	1705	0 = Temperature Input 1 (-50...200 °C) 1 = Temperature Input 2 (-50...200 °C) 2 = Temperature Input 3 (-50...200 °C) 3 = Temperature Input 4 (-50...200 °C) 4 = Temperature Input 5 (-50...200 °C) 5 = Temperature Input 6 (-50...200 °C) 6 = Analog input 1 7 = Analog input 2 8 = Analog input 3 9 = Analog input 4 10 = Analog input 5 11 = Analog input 6 12 = ProcessDataIn1 (0–100%)

Index	Parameter	Min	Max	Unit	De- fault	ID	Description
							13 = ProcessDataIn2 (0–100%) 14 = ProcessDataIn3 (0–100%) 15 = ProcessDataIn4 (0–100%) 16 = ProcessDataIn5 (0–100%) 17 = ProcessDataIn6 (0–100%) 18 = ProcessDataIn7 (0–100%) 19 = ProcessDataIn8 (0–100%) 20 = Block Out.1 21 = Block Out.2 22 = Block Out.3 23 = Block Out.4 24 = Block Out.5 25 = Block Out.6 26 = Block Out.7 27 = Block Out.8 28 = Block Out.9 29 = Block Out.10
P3.13.10.3	Temperature Signal Minimum	-100.0	P3.13.10.4	°C/°F	-50.0 (°C)	1706	
P3.13.10.4	Temperature Signal Maximum	P3.13.10.3	300.0	°C/°F	200.0 (°C)	1707	
P3.13.10.5	Frost Protection Temperature	P3.13.10.3	P3.13.10.4	°C/°F	5.00	1708	
P3.13.10.6	Frost Protection Frequency	0.0	Varies	Hz	10.0	1710	
V3.13.10.7	Frost Temperature Monitoring	Varies	Varies	°C/°F		1711	The monitoring value for the measured temperature signal in the Frost protection function. Scaling value: 0.1.

6.14 Group 3.14: External PID Controller

Table 95: Basic Settings for the External PID Controller

Index	Parameter	Min	Max	Unit	Default	ID	Description
P3.14.1.1	Enable External PID	0	1		0	1630	0 = Disabled 1 = Enabled
P3.14.1.2	Start Signal				DigIN Slot0.2	1049	OPEN = PID2 in stop mode CLOSED = PID2 regulating
P3.14.1.3	Output in Stop	0.0	100.0	%	0.0	1100	

Index	Parameter	Min	Max	Unit	Default	ID	Description
P3.14.1.4	PID Gain	0.00	1000.00	%	100.00	1631	
P3.14.1.5	PID Integration Time	0.00	600.00	s	1.00	1632	
P3.14.1.6	PID Derivation Time	0.00	100.00	s	0.00	1633	
P3.14.1.7	Process Unit Selection	0	37		0	1635	
P3.14.1.8	Process Unit Min	Varies	Varies	Varies	0	1664	
P3.14.1.9	Process Unit Max	Varies	Varies	Varies	100	1665	
P3.14.1.10	Process Unit Decimals	0	4		2	1666	
P3.14.1.11	Error Inversion	0	1		0	1636	
P3.14.1.12	Dead Band	Varies	Varies	Varies	0.0	1637	
P3.14.1.13	Dead Band Delay	0.00	320.00	s	0.00	1638	

Table 96: Setpoints of the External PID Controller

Index	Parameter	Min	Max	Unit	Default	ID	Description
P3.14.2.1	Keypad Setpoint 1	0.00	100.00	Varies	0.00	1640	
P3.14.2.2	Keypad Setpoint 2	0.00	100.00	Varies	0.00	1641	
P3.14.2.3	Setpoint Ramp Time	0.00	300.00	s	0.00	1642	
P3.14.2.4	Select Setpoint	Varies	Varies		DigIN Slot0.1	1048	OPEN = Setpoint 1 CLOSED = Setpoint 2
P3.14.2.5	Setpoint Source 1 Selection	0	32		1	1643	0 = Not Used 1 = Keypad Setpoint 1 2 = Keypad Setpoint 2 3 = AI1 4 = AI2 5 = AI3 6 = AI4 7 = AI5 8 = AI6 9 = ProcessDataIn1 10 = ProcessDataIn2 11 = ProcessDataIn3 12 = ProcessDataIn4 13 = ProcessDataIn5 14 = ProcessDataIn6 15 = ProcessDataIn7

Index	Parameter	Min	Max	Unit	Default	ID	Description
							16 = ProcessDataIn8 17 = Temperature Input 1 18 = Temperature Input 2 19 = Temperature Input 3 20 = Temperature Input 4 21 = Temperature Input 5 22 = Temperature Input 6 23 = Block Out.1 24 = Block Out.2 25 = Block Out.3 26 = Block Out.4 27 = Block Out.5 28 = Block Out.6 29 = Block Out.7 30 = Block Out.8 31 = Block Out.9 32 = Block Out.10 If temperature inputs are selected, the values of parameters P3.14.1.8 Process Unit Min and P3.14.1.9 Process Unit Max must be set to correspond to the scale of the temperature measurement board.
P3.14.2.6	Setpoint 1 minimum	-200.00	200.00	%	0.00	1644	
P3.14.2.7	Setpoint 1 maximum	-200.00	200.00	%	100.00	1645	
P3.14.2.8	Setpoint source 2 selection	0	22		2	1646	
P3.14.2.9	Setpoint 2 minimum	-200.00	200.00	%	0.00	1647	
P3.14.2.10	Setpoint 2 maximum	-200.00	200.00	%	100.00	1648	

Table 97: Feedback of the External PID Controller

Index	Parameter	Min	Max	Unit	Default	ID	Description
P3.14.3.1	Feedback Function				1	1650	
P3.14.3.2	Feedback Function Gain	-1000.0	1000.0	%	100.0	1651	
P3.14.3.3	Feedback 1 Source Selection	0	25		2	1652	
P3.14.3.4	Feedback 1 Minimum	-200.00	200.00	%	0.00	1653	
P3.14.3.5	Feedback 1 Maximum	-200.00	200.00	%	100.00	1654	

Index	Parameter	Min	Max	Unit	Default	ID	Description
P3.14.3.6	Feedback 2 Source Selection	0	25		0	1655	
P3.14.3.7	Feedback 2 Minimum	-200.00	200.00	%	0.00	1656	
P3.14.3.8	Feedback 2 Maximum	-200.00	200.00	%	100.00	1657	

Table 98: Process Supervision of the External PID Controller

Index	Parameter	Min	Max	Unit	Default	ID	Description
P3.14.4.1	Enable Supervision	0	1		0	1659	0 = Disabled 1 = Enabled
P3.14.4.2	Upper Limit	Varies	Varies	Varies	Varies	1660	
P3.14.4.3	Lower Limit	Varies	Varies	Varies	Varies	1661	
P3.14.4.4	Delay	0	30000	s	0	1662	
P3.14.4.5	Response to External PID Supervision Fault	0	3		2	757	0 = No action 1 = Alarm 2 = Fault 3 = Fault, Coast

6.15 Group 3.15: Multi-pump

Table 99: Multi-pump Parameters

Index	Parameter	Min	Max	Unit	Default	ID	Description
P3.15.1	Number of Motors	1	6		1	1001	
P3.15.2	Interlock Function	0	1		1	1032	0 = Disabled 1 = Enabled
P3.15.3	Include FC	0	1		1	1028	0 = Disabled 1 = Enabled
P3.15.4	Autochange	0	1		1	1027	0 = Disabled 1 = Enabled
P3.15.5	Autochange Interval	0.0	3000.0	h	48.0	1029	
P3.15.6	Autochange: Frequency Limit	0.00	P3.3.1.2	Hz	25.00	1031	
P3.15.7	Autochange: Motor Limit	1	6		1	1030	
P3.15.8	Bandwidth	0	100	%	10	1097	
P3.15.9	Bandwidth Delay	0	3600	s	10	1098	
P3.15.10	Motor 1 Interlock	Varies	Varies		DigIN Slot0.1	426	OPEN = Not active

Index	Parameter	Min	Max	Unit	Default	ID	Description
							CLOSED = Active
P3.15.11	Motor 2 Interlock	Varies	Varies		DigIN Slot0.1	427	See P3.15.10.
P3.15.12	Motor 3 Interlock	Varies	Varies		DigIN Slot0.1	428	See P3.15.10.
P3.15.13	Motor 4 Interlock	Varies	Varies		DigIN Slot0.1	429	See P3.15.10.
P3.15.14	Motor 5 Interlock	Varies	Varies		DigIN Slot0.1	430	See P3.15.10.
P3.15.15	Motor 6 Interlock	Varies	Varies		DigIN Slot0.1	486	See P3.15.10.
M3.15.16	Overpressure Supervision	See the overpressure supervision parameters in table Table 100 .					

Table 100: Overpressure Supervision Parameters

Index	Parameter	Min	Max	Unit	Default	ID	Description
P3.15.16.1	Enable Overpressure Supervision	0	1		0	1698	0 = Disabled 1 = Enabled
P3.15.16.2	Supervision Alarm Level	P3.13.1.5	P3.13.1.6	P3.13.1.4	0.00	1699	

6.16 Group 3.16: Maintenance Counters

Table 101: Maintenance Counters

Index	Parameter	Min	Max	Unit	Default	ID	Description
P3.16.1	Counter 1 Mode	0	2		0	1104	0 = Not used 1 = Hours 2 = Revolutions * 1000
P3.16.2	Counter 1 Alarm Limit	0	2147483647	h/kRev	0	1105	0 = Not used
P3.16.3	Counter 1 Fault Limit	0	2147483647	h/kRev	0	1106	0 = Not used
P3.16.4	Counter 1 Reset				0	1107	
P3.16.5	Counter 1 DI Reset				0	490	CLOSED = Reset

6.17 Group 3.17: Fire Mode

Table 102: Fire Mode Parameters

Index	Parameter	Min	Max	Unit	Default	ID	Description
P3.17.1	Fire Mode Password	0	9999		0	1599	1001 = Enabled 1234 = Test mode
P3.17.2	Fire Mode Frequency Source	0	18		0	1617	0 = Fire Mode frequency 1 = Preset speeds

Index	Parameter	Min	Max	Unit	Default	ID	Description
							2 = Keypad 3 = Fieldbus 4 = AI1 5 = AI2 6 = AI1 + AI2 7 = PID1 8 = Motor potentiometer 9 = Block Out.1 10 = Block Out.2 11 = Block Out.3 12 = Block Out.4 13 = Block Out.5 14 = Block Out.6 15 = Block Out.7 16 = Block Out.8 17 = Block Out.9 18 = Block Out.10
P3.17.3	Fire Mode Frequency	0.00	P3.3.1.2	Hz	50.00	1598	
P3.17.4	Fire Mode Activation on OPEN				DigIN Slot0.2	1596	OPEN = Fire Mode active CLOSED = No action
P3.17.5	Fire Mode Activation on CLOSE				DigIN Slot0.1	1619	OPEN = No action CLOSED = Fire Mode active
P3.17.6	Fire Mode Reverse				DigIN Slot0.1	1618	OPEN = Forward CLOSED = Reverse DigIN Slot0.1 = Forward DigIN Slot0.2 = Reverse
V3.17.7	Fire Mode Status	0	3			1597	0 = Disabled 1 = Enabled 2 = Activated (Enabled + DI Open) 3 = Test Mode See 5.4.2 Basic Monitoring Parameters .
V3.17.8	Fire Mode Counter	0	65535			1679	
P3.17.9	Fire Mode Run Indication Current	0	100	%	10	15580	

6.18 Group 3.18: Motor Preheat Parameters

Table 103: Motor Preheat Parameters

Index	Parameter	Min	Max	Unit	Default	ID	Description
P3.18.1	Motor Preheat Function	0	4		0	1225	0 = Not used 1 = Always in stop state 2 = Controlled by DI 3 = Temperature limit

Index	Parameter	Min	Max	Unit	Default	ID	Description
							4 = Temperature limit (Measured motor temperature)
P3.18.2	Preheat Temperature Limit	-20	100	°C	0	1226	
P3.18.3	Motor Preheat Current	0	31048	A	Varies	1227	
P3.18.4	Motor Preheat ON	Varies	Varies		DigIN Slot0.1	1044	OPEN = No action CLOSED = Preheat activated in Stop state
P3.18.5	Preheat Motor Temperature	0	6		0	1045	0 = Not Used 1 = Temperature Input 1 2 = Temperature Input 2 3 = Temperature Input 3 4 = Temperature Input 4 5 = Temperature Input 5 6 = Temperature Input 6

6.19 Group 3.19: Drive Customizer

Table 104: Drive Customizer Parameters

Index	Parameter	Min	Max	Unit	Default	ID	Description
P3.19.1	Operation Mode	0	1		1	15001	0 = Execute Program 1 = Programming

6.20 Group 3.20: Mechanical Brake

Table 105: Mechanical Brake Parameters

Index	Parameter	Min	Max	Unit	Default	ID	Description
P3.20.1	Brake Control	0	2		0	1541	0 = Disabled 1 = Enabled 2 = Enabled with brake status supervision
P3.20.2	Brake Mechanical Delay	0.00	60.00	s	0.00	1544	
P3.20.3	Brake Opening Frequency Limit	0	P3.3.1.2	Hz	2.00	1535	
P3.20.4	Brake Closing Frequency Limit	0	P3.3.1.2	Hz	2.00	1539	
P3.20.5	Brake Current Limit	0.0	Varies	A	0.0	1085	
P3.20.6	Brake Fault Delay	0.00	60.00	s	2.00	352	
P3.20.7	Response to Brake Fault	0	3		0	1316	0 = No action 1 = Alarm

Index	Parameter	Min	Max	Unit	Default	ID	Description
							2 = Fault (Stop according to stop mode) 3 = Fault (Stop by coasting)
P3.20.8	Brake Feedback				DigIN Slot0.1	1210	

6.21 Group 3.21: Pump Control

Table 106: Auto-Cleaning Parameters

Index	Parameter	Min	Max	Unit	Default	ID	Description
P3.21.1.1	Cleaning Function	0	1		0	1714	0 = Disabled 1 = Enabled
P3.21.1.2	Cleaning Activation				DigIN Slot0.1	1715	
P3.21.1.3	Cleaning Cycles	1	100		5	1716	
P3.21.1.4	Clean Forward Frequency	0.00	50.00	Hz	45.00	1717	
P3.21.1.5	Clean Forward Time	0.00	320.00	s	2.00	1718	
P3.21.1.6	Clean Reverse Frequency	0.00	50.00	Hz	45.00	1719	
P3.21.1.7	Clean Reverse Time	0.00	320.00	s	0.00	1720	
P3.21.1.8	Cleaning Acceleration Time	0.1	300.0	s	0.1	1721	
P3.21.1.9	Cleaning Deceleration Time	0.1	300.0	s	0.1	1722	

Table 107: Jockey Pump Parameters

Index	Parameter	Min	Max	Unit	Default	ID	Description
P3.21.2.1	Jockey Function	0	2		0	1674	0 = Not used 1 = PID sleep 2 = PID sleep (level)
P3.21.2.2	Jockey Start Level	0.00	100.00	%	0.00	1675	
P3.21.2.3	Jockey Stop Level	0.00	100.00	%	0.00	1676	

Table 108: Priming Pump Parameters

Index	Parameter	Min	Max	Unit	Default	ID	Description
P3.21.3.1	Priming Function	0	1		0	1677	0 = Disabled 1 = Enabled
P3.21.3.2	Priming Time	0.0	320.00		3.0	1678	

6.22 Group 3.22: Advanced Harmonic Filter

Table 109: Advanced Harmonic Filter Parameters

Index	Parameter	Min	Max	Unit	Default	ID	Description
P3.22.1	Cap Disconnect Limit	0	100	%	0	15510	
P3.22.2	Cap Disconnect Hyst	0	100	%	10	15511	
P3.22.3	AHF overtemperature				DigIN Slot0.1	15513	
P3.22.4	AHF Fault Response	0	3		3	15512	0 = No Action 1 = Alarm 2 = Fault 3 = Fault, Coast

6.23 Group 3.23: Condition-based Monitoring

Table 110: Condition-based Monitoring Parameters

Index	Name	Min	Max	Unit	Default	ID	Description
P3.23.1	Condition Based Monitoring Fault Mode	0	2		1	3540	0=No Action 1=Warnings 2=Fault + Warnings
P3.23.2 Baseline Settings							
P3.23.2.1	BaselineRun Start	0	1		0	3501	0=Disabled 1=Enabled
P3.23.2.2	BaselineRun MinFreq	P3.3.1.1	P3.3.1.2 – 1	Hz	0.00	3502	
P3.23.2.3	BaselineRun MaxFreq	P3.3.1.1 + 1	P3.3.1.2	Hz	50.00	3503	
P3.23.2.4	BaselineRun Duration	30	7200	s	120	3504	
P3.23.2.5	Modified Array	0	12		0	3505	0=Freq Points 1=Cur Max Steady 2=Cur Min Steady 3=Cur Mean Steady 4=Cur Std Steady 5=Vibr Max Ramp 6=Vibr Min Ramp 7=Vibr Mean Ramp 8=Vibr Std Ramp 9=Load Max Steady 10=Load Min Steady 11=Load Mean Steady 12=Load Std Steady
P3.23.2.6	Modified Point	0	9		0	3506	
P3.23.2.7	Modified Value	-300.00	320.00	various	0.00	3507	
P3.23.2.8	Modified Activation	0	1		0	3508	0=Disabled

Index	Name	Min	Max	Unit	Default	ID	Description
							1=Enabled
P3.23.2.9	Baseline Data Selector	0	12		0	3509	0=Freq Points 1=Cur Max Steady 2=Cur Min Steady 3=Cur Mean Steady 4=Cur Std Steady 5=Vibr Max Ramp 6=Vibr Min Ramp 7=Vibr Mean Ramp 8=Vibr Std Ramp 9=Load Max Steady 10=Load Min Steady 11=Load Mean Steady 12=Load Std Steady
P3.23.3 Stator Winding							
P3.23.3.1	Line Freq	0.00	100.00	Hz	50.00	1913	
P3.23.3.2	Line Freq Hyst	0.00	10.00	Hz	1.00	1914	
P3.23.3.3 Current Unbalance							
P3.23.3.3.1 Threshold Value							
P3.23.3.3.1.1	Mean Factor	-10.0	10.0.0		1.0	3511	
P3.23.3.3.1.2	Min Factor	-10.0	10.0.0		0.0	3512	
P3.23.3.3.1.3	Max Factor	-10.0	10.0.0		0.0	3513	
P3.23.3.3.1.4	Std Factor	-10.0	10.0.0		0.0	3514	
P3.23.3.3.1.5	Interpolation Type	0	1		1	3515	0=Constant 1=Linear
P3.23.3.3.2 Limits							
P3.23.3.3.2.1	Warning S1 Mode	0	2		0	3516	0=Abs. Value 1=Baseline Offset 2=Baseline Factor
P3.23.3.3.2.2	Warning S1 High	0.00	100.00	%	0.00	3517	
P3.23.3.3.2.3	Warning S1 Delay	0	3600	s	0	3518	
P3.23.3.3.2.4	Warning S2 Mode	0	2		0	3519	0=Abs. Value 1=Baseline Offset 2=Baseline Factor
P3.23.3.3.2.5	Warning S2 High	0.00	100.00	%	0.00	3520	
P3.23.3.2.6	Warning S2 Delay	0	3600	s	0	3521	
P3.23.3.2.7	Alarm/Fault Mode	0	2		0	3522	0=Abs. Value 1=Baseline Offset

Index	Name	Min	Max	Unit	Default	ID	Description
							2=Baseline Factor
P3.23.3.2.2.8	Alarm/Fault High	0.00	100.00	%	0.00	3523	
P3.23.3.2.2.9	Alarm/Fault Delay	0	3600	s	0	3524	
P3.23.3.3.3 Counters							
P3.23.3.3.3.1	Warning S1 Counter	0.0	360.0	s	0.0	3541	
P3.23.3.3.3.2	Warning S2 Counter	0.0	360.0	s	0.0	3542	
P3.23.3.3.3.3	Alarm/Fault Counter	0.0	360.0	s	0.0	3543	
P3.23.3.3.3.4	Stop Counter Delay	0.0	320.0	s	0.0	3549	
P3.23.4 Vibration							
P3.23.4.1	Vibration Input	0	4		0	3587	0=Not Used 1=A11 2=A12 3=A13 4=A14
P3.23.4.2 Threshold Value							
P3.23.4.2.1	Mean Factor	-10.0	10.0.0		0.0	3550	
P3.23.4.2.2	Min Factor	-10.0	10.0.0		0.0	3551	
P3.23.4.2.3	Max Factor	-10.0	10.0.0		1.0	3552	
P3.23.4.2.4	Std Factor	-10.0	10.0.0		0.0	3553	
P3.23.4.2.5	Interpolation Type	0	1		0	3554	0=Constant 1=Linear
P3.23.4.3 Limits							
P3.23.4.3.1	Warning S1 Mode	0	2		0	3555	0=Abs. Value 1=Baseline Offset 2=Baseline Factor
P3.23.4.3.2	Warning S1 High	0.00	100.00	%	0.00	3556	
P3.23.4.3.3	Warning S1 Delay	0	3600	s	0	3557	
P3.23.4.3.4	Warning S2 Mode	0	2		0	3558	0=Abs. Value 1=Baseline Offset 2=Baseline Factor
P3.23.4.3.5	Warning S2 High	0.00	100.00	%	0.00	3559	
P3.23.4.3.6	Warning S2 Delay	0	3600	s	0	3560	
P3.23.4.3.7	Alarm/Fault Mode	0	2		0	3561	0=Abs. Value 1=Baseline Offset 2=Baseline Factor

Index	Name	Min	Max	Unit	Default	ID	Description
P3.23.4.3.8	Alarm/Fault High	0.00	100.00	%	0.00	3562	
P3.23.4.3.9	Alarm/Fault Delay	0	3600	s	0	3563	
P3.23.4.4 Counters							
P3.23.4.4.1	Warning S1 Counter	0.0	360.0	s	0.0	3564	
P3.23.4.4.2	Warning S2 Counter	0.0	360.0	s	0.0	3565	
P3.23.4.4.3	Alarm/Fault Counter	0.0	360.0	s	0.0	3566	
P3.23.4.4.4	Stop Counter Delay	0.0	320.0	s	0.0	3549	
P3.23.5 Load							
P3.23.5.1 Threshold Value							
P3.23.5.1.1	Mean Factor	-10.0	10.0.0		1.0	3567	
P3.23.5.1.2	Min Factor	-10.0	10.0.0		0.0	3568	
P3.23.5.1.3	Max Factor	-10.0	10.0.0		0.0	3569	
P3.23.5.1.4	Std Factor	-10.0	10.0.0		0.0	3570	
P3.23.5.1.5	Interpolation Type	0	1		1	3571	0=Constant 1=Linear
P3.23.5.2 Limits							
P3.23.5.2.1	Warning S1 Mode	0	2		0	3572	0=Abs. Value 1=Baseline Offset 2=Baseline Factor
P3.23.5.2.2	Warning S1 Low	-300.0	300.0	%	0.00	3584	
P3.23.5.2.3	Warning S1 High	-300.0	300.0	%	0.00	3573	
P3.23.5.2.4	Warning S1 Delay	0	3600	s	0	3574	
P3.23.5.2.5	Warning S2 Mode	0	2		0	3575	0=Abs. Value 1=Baseline Offset 2=Baseline Factor
P3.23.5.2.6	Warning S2 Low	-300.0	300.0	%	0.00	3585	
P3.23.5.2.7	Warning S2 High	-300.0	300.0	%	0.00	3576	
P3.23.5.2.8	Warning S2 Delay	0	3600	s	0	3577	
P3.23.5.2.9	Alarm/Fault Mode	0	2		0	3578	0=Abs. Value 1=Baseline Offset 2=Baseline Factor
P3.23.5.2.10	Alarm/Fault Low	-300.0	300.0	%	0.00	3586	
P3.23.5.2.11	Alarm/Fault High	-300.0	300.0	%	0.00	3579	
P3.23.5.2.10	Alarm/Fault Delay	0	3600	s	0	3580	

Index	Name	Min	Max	Unit	Default	ID	Description
P3.23.5.3 Counters							
P3.23.5.3.1	Warning S1 Counter	0.0	360.0	s	0.0	3581	
P3.23.5.3.2	Warning S2 Counter	0.0	360.0	s	0.0	3582	
P3.23.5.3.3	Alarm/Fault Counter	0.0	360.0	s	0.0	3583	
P3.23.5.3.4	Stop Counter Delay	0.0	320.0	s	0.0	3549	

7 Diagnostics Menu

7.1 Faults

7.1.1 Uses of the Active Faults Submenu

When there is a fault or many faults, the display shows the name of the fault and blinks. Push [OK] to go back to the *Diagnostics* menu. The submenu *Active faults* shows the number of faults. To see the fault-time data, select a fault and push [OK].

The *Active faults* submenu can keep storage of maximum 10 faults. The submenu shows the faults in the sequence in which they occurred.

7.1.2 Reset Faults

When the drive shows a fault and stops, examine the cause of fault, and reset the fault. The fault stays active until it is reset.

There are 2 procedures to reset a fault in the local control place: with the [BACK/RESET] button and with a parameter. It is also possible to reset faults by using I/O, a fieldbus, or a PC tool.

N O T I C E

Before resetting the fault, remove the external control signal to prevent restarting the drive accidentally.

7.1.2.1 Resetting Faults with the [BACK/RESET] Button

Procedure

1. Push the [BACK/RESET] button on the keypad of the control panel for 2 seconds.

7.1.2.2 Resetting Faults with a Parameter on the Graphical Display

Faults can be reset with the parameter *Reset Faults*.

Procedure

1. Go to the *Diagnostics Menu*.
2. Go to the submenu *Reset faults*.
3. Select the parameter *Reset Faults*.

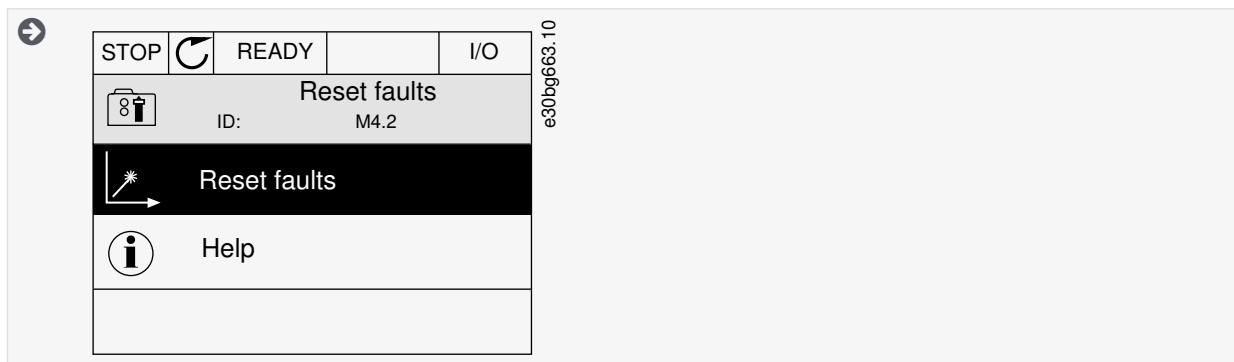

7.1.2.3 Resetting Faults with a Parameter on the Text Display

Faults can be reset with the parameter *Reset Faults*.

Procedure

1. Go to the *Diagnostics menu*.
2. Use the arrow buttons Up and Down to find the parameter *Reset Faults*.

3. Select the value Yes and push [OK].

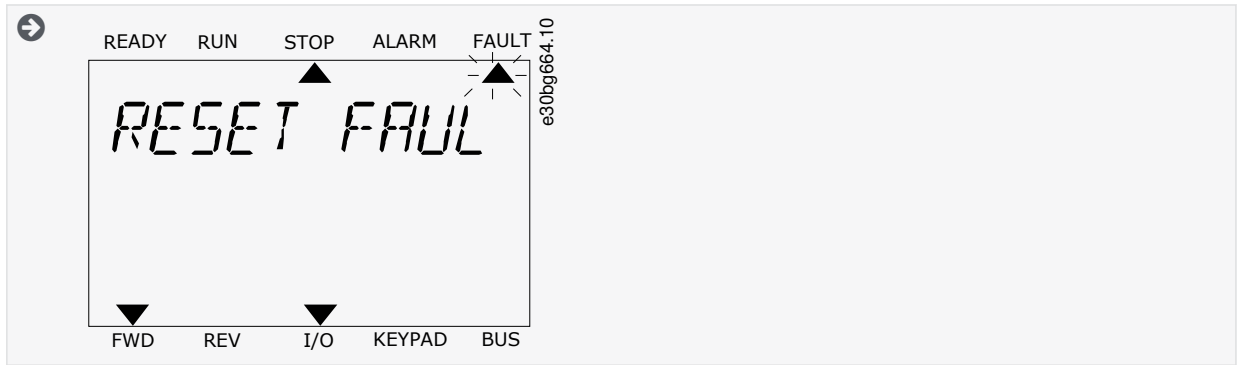

7.1.3 Uses of the Fault History

The Fault history shows more data on the faults. There is a maximum number of 40 faults in the Fault history.

7.1.3.1 Examining the Fault History on the Graphical Display

Procedure

1. To see more data on a fault, go to *Fault history*.

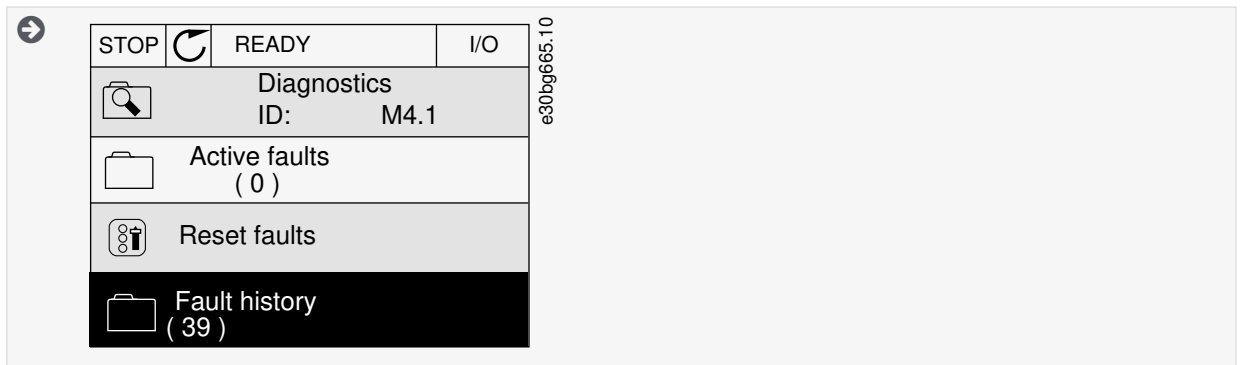

2. To examine the data of a fault, push the Arrow button Right.
3. Examine the data in a list.

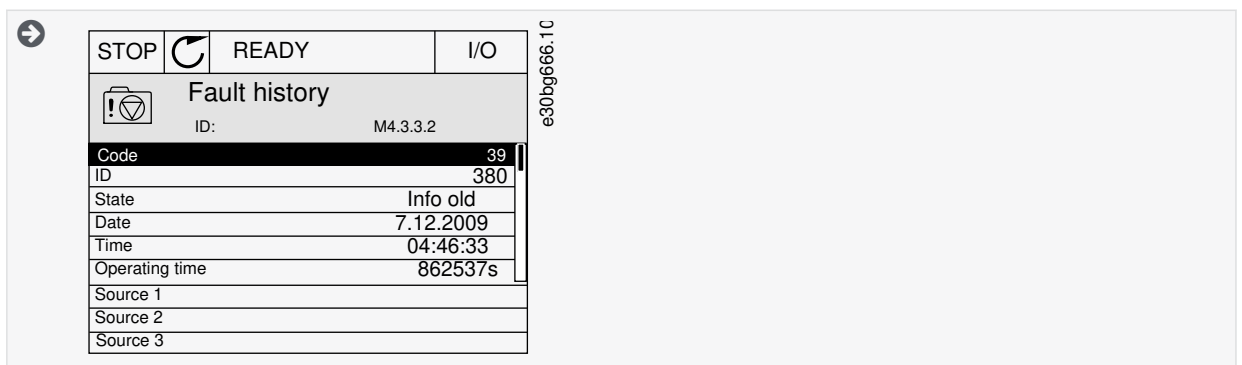

7.1.3.2 Examining the Fault History on the Text Display

Procedure

1. Push [OK] to go to *Fault history*.

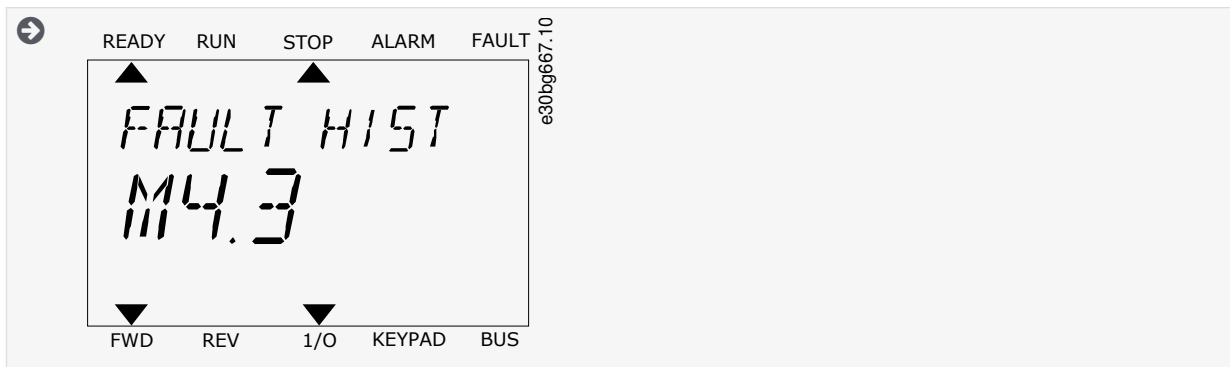

2. To examine the data of a fault, push [OK] again.
3. Use the arrow button down to examine all the data.

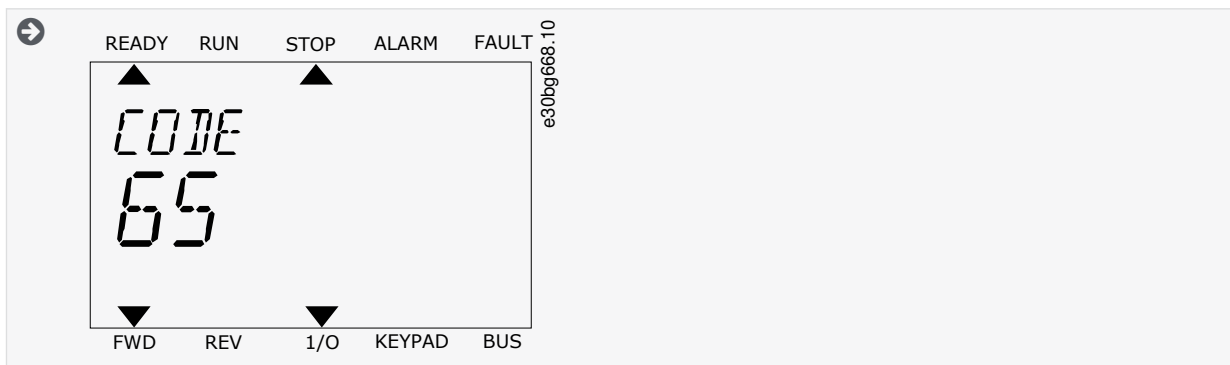

7.2 Software Info

Table 111: The Software Info Parameters in the *Diagnostics Menu*

Index	Parameter	Min	Max	Unit	De- fault	ID	Description
V4.6.1	Software Package (graphical keypad)					2524	The code for the software identification
V4.6.2	Software Package ID (text keypad)						The code for the software identification
V4.6.3	Software Package Version (text keypad)						The code for the software identification
V4.6.4	System Load	0	100	%		2300	The load on the control unit CPU
V4.6.5	Application Name (graphical keypad)					2525	The name of the application
V4.6.6	Application ID					837	The code of the application
V4.6.7	Application Version					838	
V4.6.8	Language Selections						Selected language package in software loading
V4.6.9	Keypad Software Version						

7.3 Drive Info

Table 112: The Drive Info Parameters in the *Diagnostics Menu*

Index	Parameter	Min	Max	Unit	Default	ID	Description
V4.7.1	Power Size						

7.4 Unit Status

Table 113: The Unit Status Parameters in the *Diagnostics* Menu

Index	Parameter	Min	Max	Unit	Default	ID	Description
V4.8.1	Control Unit ID					2540	Status of the control unit
V4.8.2	Power Unit ID					2541	Status of the power unit

8 I/O and Hardware Menu

8.1 Basic I/O

Table 114: The Basic I/O Parameters in the I/O and Hardware Menu

Index	Parameter	Min	Max	Unit	Default	ID	Description
V5.1.1	Digital Input 1	0	1		0	2502	Status of the digital input signal
V5.1.2	Digital Input 2	0	1		0	2503	Status of the digital input signal
V5.1.3	Digital Input 3	0	1		0	2504	Status of the digital input signal
V5.1.4	Digital Input 4	0	1		0	2505	Status of the digital input signal
V5.1.5	Digital Input 5	0	1		0	2506	Status of the digital input signal
V5.1.6	Digital Input 6	0	1		0	2507	Status of the digital input signal
V5.1.7	Analog Input 1 Mode	1	3		3	2508	Shows the mode that is set for the analog input signal. The selection is made with a DIP switch on the control board. 1 = 0...20mA 3 = 0...10V
V5.1.8	Analog Input 1	0	100	%	0.00	2509	Status of the analog input signal
V5.1.9	Analog Input 2 Mode	1	3		3	2510	Shows the mode that is set for the analog input signal. The selection is made with a DIP switch on the control board. 1 = 0...20mA 3 = 0...10V
V5.1.10	Analog Input 2	0	100	%	0.00	2511	Status of the analog input signal
V5.1.11	Analog Output 1 Mode	1	3		1	2512	Shows the mode that is set for the analog input signal. The selection is made with a DIP switch on the control board. 1 = 0...20mA 3 = 0...10V
V5.1.12	Analog Output 1	0	100	%	0.00	2513	Status of the analog output signal
V5.1.13	Relay Output 1	0	1		0	2514	Status of the relay output signal
V5.1.14	Relay Output 2	0	1		0	2515	Status of the relay output signal
V5.1.15	Relay Output 3	0	1		0	2516	Status of the relay output signal

8.2 Option Board Slots

The parameters in this menu are different for all the option boards. The parameters of the installed option board is shown. If there is no option board in the slots C, D or E, no parameters are shown. See more about the location of the slots in chapter [11.8.1.1 General Information on the Programming](#).

When an option board is removed, the fault code 39 and the fault name *Device removed* show on the display.

Table 115: Option Board Related Parameters

Menu	Function	Description
Slot C	Settings	The settings that are related to the option board.
	Monitoring	Monitor the data that is related to the option board.
Slot D	Settings	The settings that are related to the option board.
	Monitoring	Monitor the data that is related to the option board.
Slot E	Settings	The settings that are related to the option board.
	Monitoring	Monitor the data that is related to the option board.

8.3 Real-time Clock

Table 116: The Real-time Clock Parameters in the I/O and Hardware Menu

Index	Parameter	Min	Max	Unit	De- fault	ID	Description
V5.5.1	Battery State	1	3			2205	Status of the battery. 1 = Not installed 2 = Installed 3 = Replace the battery
P5.5.2	Time			hh:mm:ss		2201	The current time of the day
P5.5.3	Date			dd.mm.		2202	The current date
P5.5.4	Year			yyyy		2203	The current year
P5.5.5	Daylight Sav- ing	1	4			2204	The daylight saving rule 1 = Off 2 = EU: starts on the last Sunday in March, ends on the last Sunday in October 3 = US: starts on the 2nd Sunday in March, ends on the 1st Sunday in November 4 = Russia (permanent)
P5.5.6	Time Offset					2614	

8.4 Simple Network Time Protocol (SNTP)

The simple network time protocol (SNTP) allows devices connected to a TCP/IP network receive precise time information from designated time servers. The time information can be received either by the client device polling the time servers or the time servers broadcasting the time.

Table 117: SNTP parameters

Index	Parameter	Min	Max	Unit	Default	ID	Description
V5.5.7.1.1	SNTP Mode					3162	
V5.5.7.1.2	Server 1 IP					3163	

Index	Parameter	Min	Max	Unit	Default	ID	Description
V5.5.7.1.3	Server 2 IP					3164	
V5.5.7.1.4	SNTP Port					3165	
V5.5.7.1.5	Time Interval					3166	

8.5 Power Unit Settings

In this menu, the settings of the fan, the brake chopper, the sine filter, and the harmonic filter can be changed.

The fan operates in the optimized or the always on mode. In the optimized mode, the internal logic of the drive receives data about the temperature and controls the fan speed. After the drive goes in the Ready state, the fan stops in 5 minutes. In the always on mode, the fan operates in full speed, and does not stop.

The sine filter keeps the overmodulation depth in limits and does not let the thermal management functions decrease the switching frequency.

The harmonic filter can be enabled to avoid possible resonances in the DC link of the AC drive.

Table 118: Power Unit Settings

Index	Parameter	Min	Max	Unit	Default	ID	Description
P5.6.1.1	Fan Control Mode	0	1		1	2377	0 = Always on 1 = Optimized
V5.6.1.5	Fan Lifetime ID					849	Lifetime of the fan of the drive
P5.6.1.6	Fan lifetime alarm limit	0	200000	h	50000	824	Alarm limit of the fan lifetime
B5.6.1.7	Fan lifetime reset ID					823	Reset the fan lifetime counter with this button.
P5.6.2.1	Brake Chopper Mode	0	3		0	2526	0 = Disabled 1 = Enabled (Run) 2 = Enabled (Run & Stop) 3 = Enabled (Run, no testing)
P5.6.3.1	Max Switching Freq	1.5	Varies	kHz		2620	
P5.6.5.1	Sine Filter	0	1		0	2527	0 = Disabled 1 = Enabled
P5.6.6.1	Harmonic Filter	0	1		0	2497	0 = Disabled 1 = Enabled

8.6 Keypad

Table 119: The Keypad Parameters in the I/O and Hardware Menu

Index	Parameter	Min	Max	Unit	De- fault	ID	Description
P5.7.1	Timeout Time	0	60	min	0	804	The time after which the display goes back to the page that is set with parameter P5.7.2. 0 = Not used
P5.7.2	Default Page	0	4		0	2318	The page that the display shows when the drive is powered up, or when the time that is set with P5.7.1 is expired. If the value is set to 0, the display shows the last page that it showed. 0 = None 1 = A menu index

Index	Parameter	Min	Max	Unit	De- fault	ID	Description
							2 = Main menu 3 = Control page 4 = Multimonitor
P5.7.3	Menu Index					2499	Set a page to be the menu index. (The selection 1 in P5.7.2.)
P5.7.4	Contrast ⁽¹⁾	30	70	%	50	830	Set the contrast of the display.
P5.7.5	Backlight Time	0	60	min	5	818	Set the time after which the backlight of the display turns off. If the value is set to 0, the backlight is always on.

¹ Only available with the graphical keypad.

8.7 Fieldbus

In the I/O and Hardware menu, there are the parameters that are related to fieldbus boards. Find the instructions on how to use these parameters in the related fieldbus manual.

Table 120: Fieldbus Menu Structure

Submenu level 1	Submenu level 2	Submenu level 3	Submenu level 4
RS-485	Common settings	Protocol	Modbus RTU
			N2
			BACnet MSTP
RS-485	Modbus RTU	Parameters	Slave address
			Baud rate
			Parity type
			Stop bits
			Communication timeout
			Operate mode
		Monitoring	Fieldbus protocol status
			Communication status
			Illegal functions
			Illegal data addresses
			Illegal data values
			Slave device busy
			Memory parity error
			Slave device failure
			Last fault response
Control Word			
Status Word			

Submenu level 1	Submenu level 2	Submenu level 3	Submenu level 4
RS-485	N2	Parameters	Slave address
			Communication timeout
		Monitoring	Fieldbus protocol status
			Communication status
			Invalid data
			Invalid commands
			Command not accepted
			Control word
Status word			
RS-485	BACnet MSTP	Parameters	Baud rate
			Autobauding
			MAC address
			Instance number
			Communication timeout
		Monitoring	Fieldbus protocol status
			Communication status
			Actual instance number
			Fault code
			Control word
			Status word
Ethernet	Common settings	IP address mode	
		Duplicate IP Detection	
		Speed/Duplex	
		Ethernet Fieldbus 1	
		Ethernet Fieldbus 2	
		IP Port Filter	
		Drive PC Tool	
		Fixed IP	IP address
			Subnet mask
			Default gateway
		IP address	
Subnet mask			

Submenu level 1	Submenu level 2	Submenu level 3	Submenu level 4
		Default gateway	
		MAC address	
Ethernet	Modbus TCP ⁽¹⁾		
Ethernet	BACnet IP ⁽²⁾		
Ethernet	EtherNet/IP ⁽³⁾		
Ethernet	PROFINET I/O ⁽⁴⁾		

¹ For details, see VACON 100 Modbus User Manual.

² For details, see VACON 100 BACnet Installation Manual.

³ For details, see VACON 100 EtherNet IP Installation Manual.

⁴ For details, see VACON 100 Profinet IO Installation Manual.

8.8 Fieldbus General

Enabling Ethernet Fieldbus Protocol

Needed internal Ethernet based fieldbus protocols can be enabled with parameters “Ethernet Fieldbus 1”, 5.9.1.4 (ID 2622) and “Ethernet Fieldbus 2”, 5.9.1.5 (ID 2623). The parameters are included since VACON®100 INDUSTRIAL V030 and VACON®100 FLOW V022 firmware.

Both parameters contain the same list with “PROFINET I/O, EtherNet/IP, BACnet/IP and Modbus TCP” protocols. PROFINET I/O and EtherNet/IP are visible only if included in drive configuration. By default Modbus TCP is enabled, but if not used, it is recommended to turn it off.

If the same fieldbus is selected to both parameters, the fieldbus protocol is still activated only once. Protocol specific menu tree becomes visible only after enabling it from these parameters. When using VACON®Live, to see protocol specific menus, the “5.9 Ethernet” menu tree must be reloaded after enabling the protocols.

When restoring parameters from older firmware version, drive checks on start-up which protocols were enabled in old firmware and sets up these new parameters accordingly. After having restored parameters, restart the drive. If more than two Ethernet fieldbuses were activated in old firmware, new firmware allows it. In this case, these two new parameters show “None”, but when the values are changed, all Ethernet fieldbuses are stopped, and only the enabled ones are started.

Table 121: Fieldbus Common Settings

Index	Parameter	Min	Max	Unit	Default	ID	Description
P5.9.1.4	Ethernet Fieldbus 1	None	BACnet/IP ⁽¹⁾		None	2622	2 Ethernet-based internal fieldbuses can be enabled at a time. Select fieldbus from the list.
P5.9.1.5	Ethernet Fieldbus 2	None	BACnet/IP ⁽¹⁾		Modbus TCP	2623	
P5.9.1.6	IP Port Filter	0	65535		0	2641	Use this parameter to block IP ports/protocols.
P5.9.1.7	Drive PC Tool	Configuration	Disabled		Configuration	2642	Use this parameter to block VACON®PC Tools over Ethernet, for example, VACON®Live.

¹ Depends on fieldbuses included in drive configuration

Table 122: Fieldbus General

Index	Parameter	Min	Max	Unit	Default	ID	Description
P5.13.1	Controlling Fieldbus					2539	
V5.13.2	Controlling Fieldbus					2610	

8.9 STO

Table 123: STO Parameters

Index	Parameter	Min	Max	Unit	Default	ID	Description
V5.12.1.1	Channel 1	0	1		0		See VACON® 100 OPTBJ STO Option Board User Manual.
V5.12.1.2	Channel 2	0	1		0		
P5.12.2.1	Fan Stop on STO	Disabled	Enabled		Disabled	2616	

N O T I C E

These parameters are only visible when an STO option board is connected.

8.10 Fieldbus Redundancy

VACON® 100 supports the usage of two fieldbus connections. The drive accepts control data only from the primary fieldbus. If the primary fieldbus connection fails, the control can be automatically switched to a secondary fieldbus using the fieldbus redundancy control. VACON® 100 built-in fieldbus protocols support fieldbus redundancy control. The only exception is RS485 N2, which does not support fieldbus redundancy. Recent firmware versions of fieldbus option boards also support fieldbus redundancy.

When *switch on failing* mode is selected, and the current fieldbus connection detects missing communication from the controller, the switchover command is given to change to the other fieldbus connection. When *switch on faulted* mode is selected, and the current fieldbus connection gets a timeout, the switchover command is given to change to the other fieldbus connection.

The switchback functionality forces a change back to the primary fieldbus connection when it is in operational state and when the given time delay has elapsed. If the switchback functionality is deactivated, the switchover between the fieldbus connections is only performed when the currently controlling fieldbus begins to fail or becomes faulted.

The currently controlling fieldbus protocol can be checked from the monitoring value *V5.13.2 Controlling Fieldbus* (ID 2610).

Table 124: Fieldbus Redundancy

Index	Parameter	Min	Max	Unit	Default	ID	Description
P5.13.3.1	Redundancy Mode	0	2		0	2606	0 = Disabled 1 = Switch on failing 2 = Switch on faulted
P5.13.3.2	Primary Fieldbus Connection				0	2607	
P5.13.3.3	Secondary Fieldbus Connection				0	2608	
P5.13.3.4	Switchover Timeout	0	65535	ms	0	2609	
P5.13.3.5	Switchback Timeout	0	65535	s	10	2612	
V5.13.3.6	Switchover Counter					2611	

9 User Settings, Favourites, and User Level Menus

9.1 User Settings

9.1.1 User Settings Parameters

Table 125: General Settings in the User Settings Menu

Index	Parameter	Min	Max	Unit	Default	ID	Description
P6.1	Language selection	Varies	Varies		Varies	802	The selection is different in all the language packages.
M6.5	Parameter back-up						See 9.1.2 Parameter Back-up Parameters .
M6.6	Parameter compare						See 9.1.3 Parameter Compare Parameters .
P6.7	Drive name					2528	Use VACON [®] Live PC tool to give a name to the drive if necessary.
M6.8	Licenses						See 9.1.4 License Parameters .

9.1.2 Parameter Back-up Parameters

Table 126: The Parameter Back-up Parameters in the User Settings menu

Index	Parameter	Min	Max	Unit	De- fault	ID	Description
B6.5.1	Restore Factory Defaults					831	Restores the default parameter values and starts the Startup wizard.
P6.5.2	Save to Keypad ⁽¹⁾	0	1		0	2478	Saves the parameter values to the control panel, for example to copy them to another drive. 0 = No 1 = Yes
P6.5.3	Restore from Keypad ⁽¹⁾					2488	Loads the parameter values from the control panel to the drive.
B6.5.4	Save to Set 1					2489	Keeps a customized parameter set (that is, all the parameters included in the application).
B6.5.5	Restore from Set 1					2490	Loads the customized parameter set to the drive.
B6.5.6	Save to Set 2					2491	Keeps another customized parameter set (that is, all the parameters included in the application).
B6.5.7	Restore from Set 2					2492	Loads the customized parameter set 2 to the drive.

¹ Only available with the graphical display.

9.1.3 Parameter Compare Parameters

Table 127: Parameter Compare Parameters in the User Settings Menu

Index	Parameter	Min	Max	Unit	Default	ID	Description
B6.6.1	Active set - Set 1					2493	
B6.6.2	Active set - Set 2					2494	
B6.6.3	Active set - Defaults					2495	
B6.6.4	Active set - Keypad Set					2496	

9.1.4 License Parameters

Table 128: License Parameters in the User Settings Menu

Index	Parameter	Min	Max	Unit	Default	ID	Description
P6.8.1	Insert License						Insert a drive-specific license to enable new features or remove added features.

9.2 Favourites

9.2.1 Using the Favourites Menu

This menu is available on the control panel with the graphical display, but not on the control panel with the text display. This menu is not available in the VACON® Live tool.

If the same items are used frequently, they can be added into *Favourites*. Collect a set of parameters or monitoring signals from all the control panel menus. It is not necessary to find them in the menu structure one by one. As an alternative, add them into the *Favourites* folder where it is easy to find them.

9.2.2 Adding an Item to the Favourites

It is possible to add frequently used items into *Favourites* where they are easily accessible.

Procedure

1. Find the item to be added to *Favourites*. Push the [OK] button.
2. Select *Add to favourites* and push the [OK] button.

The steps are now completed.

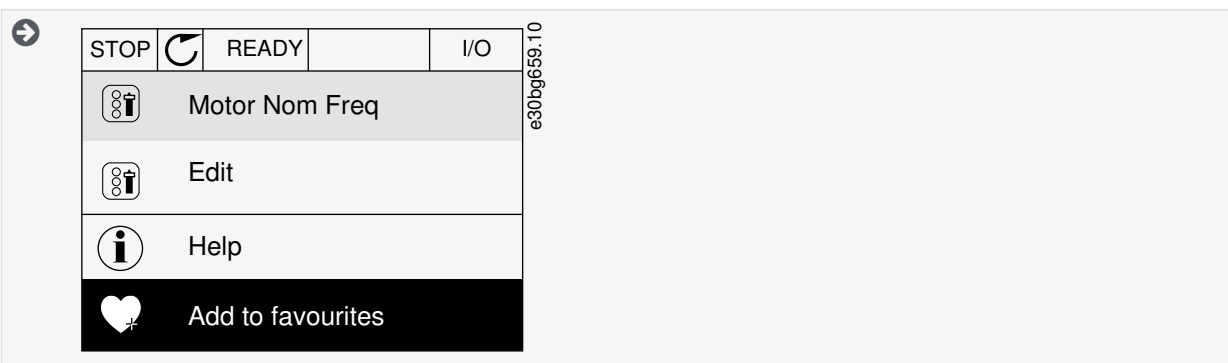

3. To continue, read the instructions on the display.

9.2.3 Removing an Item from the Favourites

Procedure

1. Go to the *Favourites*.
2. Find the item to be removed. Push the [OK] button.

Application Guide

3. Select *Rem from favourites*.

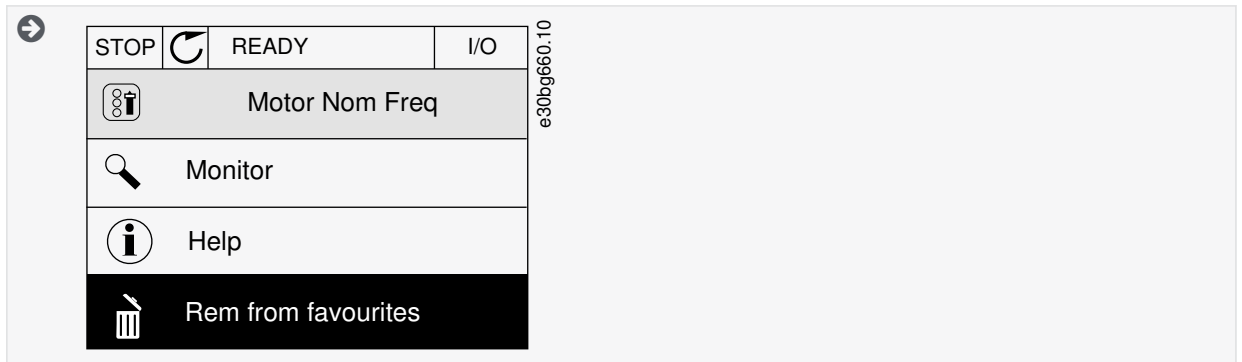

4. To remove the item, push the [OK] button again.

9.3 User Levels

9.3.1 Using the User Levels Menu

Use the *User level* parameters to keep the personnel who are not approved from changing the parameters. Also accidental changes in the parameters can be prevented.

When a user level is selected, the user cannot see all the parameters on the display of the control panel.

9.3.2 The User Level Parameters

Table 129: The User Level Parameters

In- dex	Param- eter	Min	Max	Unit	De- fault	ID	Description
P8.1	User Level	1	3		1	1194	1 = Normal. All the menus are visible in the main menu. 2 = Monitoring. Only the monitoring and user level menus are visible in the main menu. 3 = Favourites. Only the favourites and user level menus are visible in the main menu. 4 = Monitoring & Favourites. Monitoring, favourites and user level menus are visible in the main menu.
P8.2	Access Code	0	99999		0	2362	If the value is set to be other than 0 before going to Monitoring from, for example, Normal, the access code has to be given when going back to Normal. This prevents personnel who are not approved from making changes in the parameters on the control panel. NOTE! Do not lose the access code. If the access code is lost, contact your nearest service center or partner.

9.3.3 Changing the Access Code of the User Levels

Procedure

1. Go to the *User levels*.

Application Guide

- Go to the item *Access code* and push the arrow button Right.

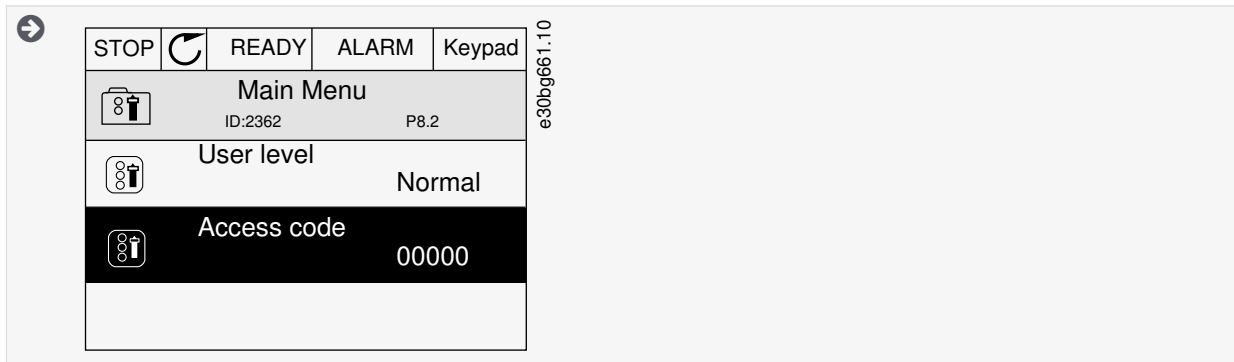

- To change the digits of the *Access code*, use all the arrow buttons.

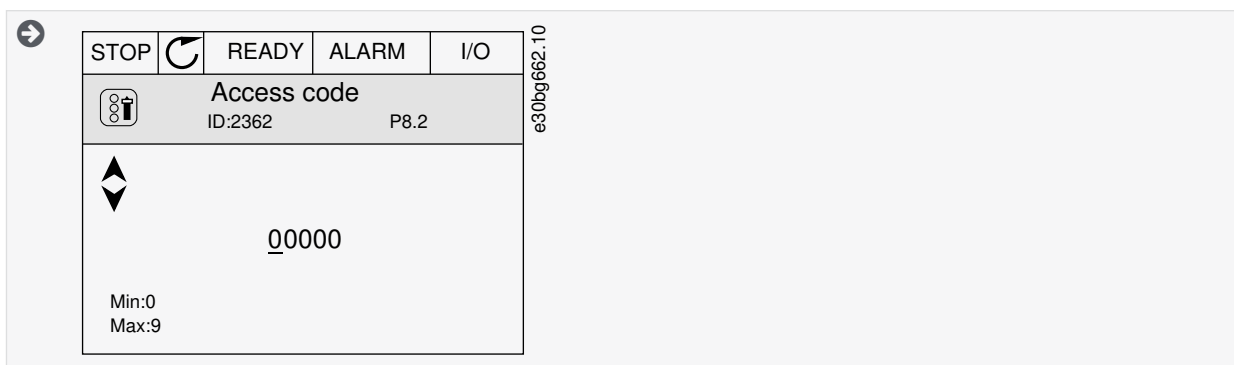

- Accept the change with the [OK] button.

10 Monitoring value descriptions

10.1 Multimonitor

10.1.1 (ID 25) Frequency Reference

- Location in the menu with default settings: **V2.1.1** (In *Multimonitor* menu)
- Location in the menu: **V2.3.2** (In *Basic* menu)

This monitoring value shows the actual frequency reference to the motor control.
The value is updated at 10 ms interval.

10.1.2 (ID 1) Output Frequency

- Location in the menu with default settings: **V2.1.2** (In *Multimonitor* menu)
- Location in the menu: **V2.3.1** (In *Basic* menu)

This monitoring value shows the actual output frequency to the motor.

10.1.3 (ID 3) Motor Current

- Location in the menu with default settings: **V2.1.3** (In *Multimonitor* menu)
- Location in the menu: **V2.3.4** (In *Basic* menu)

This monitoring value shows the measured current of the motor.
The scaling of the value is different for different drive sizes.

10.1.4 (ID 2) Motor Speed

- Location in the menu with default settings: **V2.1.4** (In *Multimonitor* menu)
- Location in the menu: **V2.3.3** (In *Basic* menu)

This monitoring value shows the actual speed of the motor in RPM (calculated value).

10.1.5 (ID 4) Motor Torque

- Location in the menu with default settings: **V2.1.5** (In *Multimonitor* menu)
- Location in the menu: **V2.3.5** (In *Basic* menu)

This monitoring value shows the actual torque of the motor (calculated value).

10.1.6 (ID 5) Motor Shaft Power

- Location in the menu with default settings: **V2.1.6** (In *Multimonitor* menu)
- Location in the menu: **V2.3.7** (In *Basic* menu)

This monitoring value shows the actual shaft power of the motor (calculated value) as a percentage of the motor nominal power.

10.1.7 (ID 6) Motor Voltage

- Location in the menu with default settings: **V2.1.7** (In *Multimonitor* menu)
- Location in the menu: **V2.3.9** (In *Basic* menu)

This monitoring value shows the actual output voltage to the motor.

10.1.8 (ID 7) DC Link Voltage

- Location in the menu with default settings: **V2.1.8** (In *Multimonitor* menu)
- Location in the menu: **V2.3.10** (In *Basic* menu)

This monitoring value shows the measured voltage in the DC link of the drive.

10.1.9 (ID 8) Unit Temperature

- Location in the menu with default settings: **V2.1.9** (In *Multimonitor* menu)
- Location in the menu: **V2.3.11** (In *Basic* menu)

This monitoring value shows the measured heat sink temperature of the drive.

The unit of measurement is degrees Celsius or Fahrenheit, depending on parameter C/F Selection (ID 1197) value.

10.2 Basic

10.2.1 (ID 1) Output Frequency

- Location in the menu with default settings: **V2.1.2** (In *Multimonitor* menu)
- Location in the menu: **V2.3.1** (In *Basic* menu)

This monitoring value shows the actual output frequency to the motor.

10.2.2 (ID 25) Frequency Reference

- Location in the menu with default settings: **V2.1.1** (In *Multimonitor* menu)
- Location in the menu: **V2.3.2** (In *Basic* menu)

This monitoring value shows the actual frequency reference to the motor control.

The value is updated at 10 ms interval.

10.2.3 (ID 2) Motor Speed

- Location in the menu with default settings: **V2.1.4** (In *Multimonitor* menu)
- Location in the menu: **V2.3.3** (In *Basic* menu)

This monitoring value shows the actual speed of the motor in RPM (calculated value).

10.2.4 (ID 3) Motor Current

- Location in the menu with default settings: **V2.1.3** (In *Multimonitor* menu)
- Location in the menu: **V2.3.4** (In *Basic* menu)

This monitoring value shows the measured current of the motor.

The scaling of the value is different for different drive sizes.

10.2.5 (ID 4) Motor Torque

- Location in the menu with default settings: **V2.1.5** (In *Multimonitor* menu)
- Location in the menu: **V2.3.5** (In *Basic* menu)

This monitoring value shows the actual torque of the motor (calculated value).

10.2.6 (ID 5) Motor Shaft Power

- Location in the menu with default settings: **V2.1.6** (In *Multimonitor* menu)
- Location in the menu: **V2.3.7** (In *Basic* menu)

This monitoring value shows the actual shaft power of the motor (calculated value) as a percentage of the motor nominal power.

10.2.7 (ID 73) Motor Shaft Power

Location in the menu: **V2.3.8**

This monitoring value shows the actual shaft power of the motor (calculated value). The unit of measurement is kW or hp, depending on parameter kW/hp Selection (ID 1198) value.

The number of decimals in the value of this monitoring value varies depending on the size of the AC drive. In fieldbus control, ID 15592 can be mapped as Process Data Out to determine how many decimals are used. The last significant digit tells the amount of decimals.

10.2.8 (ID 6) Motor Voltage

- Location in the menu with default settings: **V2.1.7** (In *Multimonitor* menu)
- Location in the menu: **V2.3.9** (In *Basic* menu)

This monitoring value shows the actual output voltage to the motor.

10.2.9 (ID 7) DC Link Voltage

- Location in the menu with default settings: **V2.1.8** (In *Multimonitor* menu)
- Location in the menu: **V2.3.10** (In *Basic* menu)

This monitoring value shows the measured voltage in the DC link of the drive.

10.2.10 (ID 8) Unit Temperature

- Location in the menu with default settings: **V2.1.9** (In *Multimonitor* menu)
- Location in the menu: **V2.3.11** (In *Basic* menu)

This monitoring value shows the measured heat sink temperature of the drive.

The unit of measurement is degrees Celsius or Fahrenheit, depending on parameter C/F Selection (ID 1197) value.

10.2.11 (ID 9) Motor Temperature

Location in the menu: **V2.3.12**

This monitoring value shows the calculated motor temperature in percentage of the nominal working temperature.

When the value rises above 105%, motor thermal protection fault occurs.

10.2.12 (ID 1228) Motor Preheat

Location in the menu: **V2.3.13**

This monitoring value shows the status of the motor preheat function.

10.2.13 (ID 18) Torque Reference

Location in the menu: **V2.3.14**

This monitoring value shows the final torque reference for motor control.

10.3 I/O

10.3.1 (ID 15) SlotA DIN 1,2,3

Location in the menu: **V2.4.1**

This monitoring value shows the status of the digital inputs 1–3 in slot A (standard I/O).

10.3.2 (ID 16) SlotA DIN 4,5,6

Location in the menu: **V2.4.2**

This monitoring value shows the status of the digital inputs 4–6 in slot A (standard I/O).

10.3.3 (ID 17) SlotB RO 1,2,3

Location in the menu: **V2.4.3**

This monitoring value shows the status of the relay outputs 1–3 in slot B.

10.3.4 (ID 59) Analog Input 1

Location in the menu: **V2.4.4**

This monitoring value shows the value of the analog input signal as a percentage of the used range.

10.3.5 (ID 60) Analog Input 2

Location in the menu: **V2.4.5**

This monitoring value shows the value of the analog input signal as a percentage of the used range.

10.3.6 (ID 61) Analog Input 3

Location in the menu: **V2.4.6**

This monitoring value shows the value of the analog input signal as a percentage of the used range.

10.3.7 (ID 62) Analog Input 4

Location in the menu: **V2.4.7**

This monitoring value shows the value of the analog input signal as a percentage of the used range.

10.3.8 (ID 75) Analog Input 5

Location in the menu: **V2.4.8**

This monitoring value shows the value of the analog input signal as a percentage of the used range.

10.3.9 (ID 76) Analog Input 6

Location in the menu: **V2.4.9**

This monitoring value shows the value of the analog input signal as a percentage of the used range.

10.3.10 (ID 81) SlotA AO 1

Location in the menu: **V2.4.10**

This monitoring value shows the value of the analog output as a percentage of the used range.

10.4 Temperature Inputs

The monitoring values related to temperature input settings are only available if a B8 or BH option board is installed.

10.4.1 (ID 50) Temperature Input 1

Location in the menu: **V2.5.1i**

This monitoring value shows the measured value of the temperature. The unit of the monitoring value is degrees Celsius or Fahrenheit, depending on parameter C/F Selection (ID 1197) value.

The list of temperature inputs is made of the first 6 available temperature inputs. The list starts from slot A and ends in slot E. If an input is available but no sensor is connected, the list shows the maximum value because the measured resistance is endless. To make the value go to its minimum value, hardwire the input.

10.4.2 (ID 51) Temperature Input 2

Location in the menu: **V2.5.2**

This monitoring value shows the measured value of the temperature. The unit of the monitoring value is degrees Celsius or Fahrenheit, depending on parameter C/F Selection (ID 1197) value.

10.4.3 (ID 52) Temperature Input 3

Location in the menu: **V2.5.3**

This monitoring value shows the measured value of the temperature. The unit of the monitoring value is degrees Celsius or Fahrenheit, depending on parameter C/F Selection (ID 1197) value.

10.4.4 (ID 69) Temperature Input 4

Location in the menu: **V2.5.4**

This monitoring value shows the measured value of the temperature. The unit of the monitoring value is degrees Celsius or Fahrenheit, depending on parameter C/F Selection (ID 1197) value.

10.4.5 (ID 70) Temperature Input 5

Location in the menu: **V2.5.5**

This monitoring value shows the measured value of the temperature. The unit of the monitoring value is degrees Celsius or Fahrenheit, depending on parameter C/F Selection (ID 1197) value.

10.4.6 (ID 71) Temperature Input 6

Location in the menu: **V2.5.6**

This monitoring value shows the measured value of the temperature. The unit of the monitoring value is degrees Celsius or Fahrenheit, depending on parameter C/F Selection (ID 1197) value.

10.5 Extras and Advanced

10.5.1 (ID 43) Drive Status Word

Location in the menu: **V2.6.1**

This monitoring value shows the bit-coded status of the drive.

10.5.2 (ID 78) Ready Status

Location in the menu: **V2.6.2**

This monitoring value shows the bit-coded data about the Ready criteria of the drive. This data is useful for monitoring when the drive is not in the Ready state.

NOTICE

The values are visible as checkboxes on the graphical display. If a box is selected, the value is active.

10.5.3 (ID 89) Application Status Word 1

Location in the menu: **V2.6.3**

This monitoring value shows the bit-coded statuses of the application.

NOTICE

The values are visible as checkboxes on the graphical display. If a box is selected, the value is active.

10.5.4 (ID 90) Application Status Word 2

Location in the menu: **V2.6.4**

This monitoring value shows the bit-coded statuses of the application.

NOTICE

The values are visible as checkboxes on the graphical display. If a box is selected, the value is active.

10.5.5 (ID 56) DIN Status Word 1

Location in the menu: **V2.6.5**

This monitoring value shows the bit-coded status of the digital input signals.

The monitoring value is a 16-bit word, where each bit shows the status of 1 digital input. From each slot, 6 digital inputs are read. Word 1 starts from the input 1 in slot A (bit0) and ends with input 4 in slot C (bit15).

10.5.6 (ID 57) DIN Status Word 2

Location in the menu: **V2.6.6**

This monitoring value shows the bit-coded status of the digital input signals.

The monitoring value is a 16-bit word, where each bit shows the status of 1 digital input. From each slot, 6 digital inputs are read. Word 2 starts from the input 5 in slot C (bit0) and ends with input 6 in slot E (bit13).

10.5.7 (ID 45) Motor Current 1 Deci

Location in the menu: **V2.6.7**

This monitoring value shows the measured current of the motor with the fixed number of decimals and that is less filtered. This monitoring value can be used, for example, with fieldbus to get the correct value so that the enclosure size does not have an effect. It can also be used for monitoring when less filtering time is needed for the motor current.

10.5.8 (ID 1495) Frequency Reference Source

Location in the menu: **V2.6.8**

This monitoring value shows the momentary frequency reference source.

10.5.9 (ID 37) Last Active Fault Code

Location in the menu: **V2.6.9**

This monitoring value shows the fault code of latest activated fault that is not reset.

10.5.10 (ID 95) Last Active Fault ID

Location in the menu: **V2.6.10**

This monitoring value shows the fault ID of latest activated fault that is not reset.

10.5.11 (ID 74) Last Active Alarm Code

Location in the menu: **V2.6.11**

This monitoring value shows the alarm code of latest activated alarm that is not reset.

10.5.12 (ID 94) Last Active Alarm ID

Location in the menu: **V2.6.12**

This monitoring value shows the alarm ID of latest activated alarm that is not reset.

10.5.13 (ID 77) Motor Regulator Status

Location in the menu: **V2.6.13**

This monitoring value shows the bit-coded status of the motor limit controllers.

NOTICE

The values are visible as checkboxes on the graphical display. If a box is selected, the limit controller is active.

10.5.14 (ID 98) Motor Shaft Power 1 Decimal

Location in the menu: **V2.6.14**

This monitoring value shows the actual shaft power of the motor (calculated value with one decimal). The unit of measurement is kW or hp, depending on parameter kW/hp Selection (ID 1198) value.

10.6 Timer Functions

10.6.1 (ID 1441) TC 1, TC 2, TC 3

Location in the menu: **V2.7.1**

This monitoring value shows the status of the time channels 1, 2 and 3.

10.6.2 (ID 1442) Interval 1

Location in the menu: **V2.7.2**

This monitoring value shows the status of the interval function.

10.6.3 (ID 1443) Interval 2

Location in the menu: **V2.7.3**

This monitoring value shows the status of the interval function.

10.6.4 (ID 1444) Interval 3

Location in the menu: **V2.7.4**

This monitoring value shows the status of the interval function.

10.6.5 (ID 1445) Interval 4

Location in the menu: **V2.7.5**

This monitoring value shows the status of the interval function.

10.6.6 (ID 1446) Interval 5

Location in the menu: **V2.7.6**

This monitoring value shows the status of the interval function.

10.6.7 (ID 1447) Timer 1

Location in the menu: **V2.7.7**

The monitoring value shows the remaining time on the timer if the timer is active.

10.6.8 (ID 1448) Timer 2

Location in the menu: **V2.7.8**

The monitoring value shows the remaining time on the timer if the timer is active.

10.6.9 (ID 1449) Timer 3

Location in the menu: **V2.7.9**

The monitoring value shows the remaining time on the timer if the timer is active.

10.6.10 (ID 1450) Real-time Clock

Location in the menu: **V2.7.10**

This monitoring value shows the actual time of the real-time clock in a format of hh:mm:ss.

10.7 PID Controller

10.7.1 (ID 20) PID Setpoint

Location in the menu: **V2.8.1**

This monitoring value shows the value of the PID setpoint signal in process units. Use the parameter P3.13.1.7 to select the process unit (See [11.16.1.4 \(ID 1036\) Process Unit Selection](#)).

10.7.2 (ID 21) PID Feedback

Location in the menu: **V2.8.2**

This monitoring value shows the value of the PID feedback signal in process units. Use the parameter P3.13.1.7 to select the process unit (See [11.16.1.4 \(ID 1036\) Process Unit Selection](#)).

10.7.3 (ID 22) PID Error

Location in the menu: **V2.8.3**

This monitoring value shows the error value of the PID controller.

The error value is the deviation of PID feedback from the PID setpoint in process unit. Use the parameter P3.13.1.7 to select the process unit (See [11.16.1.4 \(ID 1036\) Process Unit Selection](#)).

10.7.4 (ID 23) PID Output

Location in the menu: **V2.8.4**

This monitoring value shows the output of the PID controller as a percentage (0–100%).

Give this value to the motor control (frequency reference) or to an analog output.

10.7.5 (ID 24) PID Status

Location in the menu: **V2.8.5**

This monitoring value shows the state of the PID controller.

10.8 External PID Controller

10.8.1 (ID 83) EXTPID Setpoint

Location in the menu: **V2.9.1**

This monitoring value shows the value of the PID setpoint signal in process units. Use the parameter P3.14.1.10 to select the process unit (See [11.17.1.10 \(ID 1666\) Process Unit Decimals](#)).

10.8.2 (ID 85) EXTPID Error

Location in the menu: **V2.9.3**

This monitoring value shows the error value of the PID controller. The error value is the deviation of PID feedback from the PID setpoint in process unit. Use the parameter P3.14.1.10 to select the process unit (See [11.17.1.10 \(ID 1666\) Process Unit Decimals](#)).

10.8.3 (ID 84) EXTPID Feedback

Location in the menu: **V2.9.2**

This monitoring value shows the value of the PID feedback signal in process units. Use the parameter P3.14.1.10 to select the process unit (See [11.17.1.10 \(ID 1666\) Process Unit Decimals](#)).

10.8.4 (ID 86) EXTPID Output

Location in the menu: **V2.9.4**

This monitoring value shows the output of the PID controller as a percentage (0–100%). Give this value to, for example, the analog output.

10.8.5 (ID 87) EXTPID Status

Location in the menu: **V2.9.5**

This monitoring value shows the state of the PID controller.

10.9 Multi-pump

10.9.1 (ID 30) Motors Running

Location in the menu: **V2.10.1**

This monitoring value shows the actual number of motors that operate in the Multi-pump system.

10.9.2 (ID 1114) Autochange

Location in the menu: **V2.10.2**

This monitoring value shows the status of the autochange requested.

10.10 Maintenance Counters

10.10.1 (ID 1101) Maintenance Counter 1

Location in the menu: **V2.11.1**

This monitoring value shows the status of the maintenance counter. The status of the maintenance counter is shown as revolutions multiplied by 1000, or in hours. For the configuration and activation of this counter, see [11.19.1 The Maintenance Counters](#).

10.11 Fieldbus Data

10.11.1 (ID 874) FB Control Word

Location in the menu: **V2.12.1**

This monitoring value shows the status of the fieldbus control word that the application uses in bypass mode. Depending on the fieldbus type or profile, the data that is received from the fieldbus can be modified before it is sent to the application.

Bit	Value = 0 (FALSE)	Value = 1 (TRUE)
Bit 0	Stop request from Fieldbus	Start request from Fieldbus
Bit 1	Forward direction request	Reverse direction request
Bit 2	No action	Reset active faults and alarms (on rising edge 0=>1)
Bit 3	No action	Force stop mode to Coasting
Bit 4	No action	Force stop mode to Ramping

Bit	Value = 0 (FALSE)	Value = 1 (TRUE)
Bit 5	No action (normal deceleration ramp time)	Force drive to use fast deceleration ramp time (1/3 of normal deceleration time)
Bit 6	No action	Freeze drive frequency reference
Bit 7	No action	Force Fieldbus frequency reference to zero
Bit 8	No action	Force drive control place to Fieldbus control
Bit 9	No action	Force drive reference source to Fieldbus reference
Bit 10	No action	Jogging Reference 1 activation NOTE! This starts the drive.
Bit 11	No action	Jogging Reference 2 activation NOTE! This starts the drive.
Bit 12	No action	Activate Quick Stop function NOTE! This stops the drive according to setting in parameter menu M3.9.5.
Bit 13	Reserved	Reserved
Bit 14	Reserved	Reserved
Bit 15	Reserved	Reserved

10.11.2 (ID 864) FB Status Word

Location in the menu: V2.12.2

This monitoring value shows the status of the fieldbus status word that the application uses in bypass mode. Depending on the fieldbus type or profile, the data can be modified before it is sent to the fieldbus.

Bit	Value = 0 (FALSE)	Value = 1 (TRUE)
Bit 0	Not ready to operate	Ready to operate
Bit 1	Not running	Running
Bit 2	Behavior depends on P3.6.17	Behavior depends on P3.6.17
Bit 3	No fault	Fault is active
Bit 4	No alarm	Alarm is active
Bit 5	Requested speed not reached	Running at requested speed
Bit 6	Actual speed of the drive not zero	Actual speed of the drive is zero
Bit 7	Motor not magnetized (flux not ready)	Motor magnetized (flux ready)
Bit 8	No action	Reserved
Bit 9	Reserved	Reserved
Bit 10	Reserved	Reserved
Bit 11	Reserved	Reserved
Bit 12	Reserved	Reserved

Bit	Value = 0 (FALSE)	Value = 1 (TRUE)
Bit 13	Reserved	Reserved
Bit 14	Reserved	Reserved
Bit 15	Reserved	Reserved

10.11.3 (ID 875) FB Speed Reference

Location in the menu: **V2.12.3**

This monitoring value shows the fieldbus frequency reference as a percentage of minimum frequency to maximum frequency. The speed reference information is scaled between the minimum and the maximum frequency at the moment when the application received it. The minimum and the maximum frequencies can be changed after the application received the reference without an effect on the reference.

10.11.4 (ID 865) FB Speed Actual

Location in the menu: **V2.12.4**

This monitoring value shows the actual speed of the drive as a percentage of minimum frequency and maximum frequency. The value 0% indicates the minimum frequency and the value 100% indicates the maximum frequency. This monitoring value is continuously updated depending on the momentary min and max frequencies and the output frequency.

10.11.5 (ID 861) Fieldbus General Control Word

Location in the menu: **V2.12.5**

This monitoring value shows the fieldbus general control word value. The value is shown in hexadecimal format.

10.11.6 (ID 862) Fieldbus General Status Word

Location in the menu: **V2.12.6**

This monitoring value shows the fieldbus general status word value. The value is shown in hexadecimal format.

10.11.7 Fieldbus Data In

10.11.7.1 (ID 876) FB Data IN 1

Location in the menu: **V2.12.7.1**

This monitoring value shows the raw value of process data in a 32-bit signed format.

10.11.7.2 (ID 877) FB Data IN 2

Location in the menu: **V2.12.7.2**

This monitoring value shows the raw value of process data in a 32-bit signed format.

10.11.7.3 (ID 878) FB Data IN 3

Location in the menu: **V2.12.7.3**

This monitoring value shows the raw value of process data in a 32-bit signed format.

10.11.7.4 (ID 879) FB Data IN 4

Location in the menu: **V2.12.7.4**

This monitoring value shows the raw value of process data in a 32-bit signed format.

10.11.7.5 (ID 880) FB Data IN 5

Location in the menu: **V2.12.7.5**

This monitoring value shows the raw value of process data in a 32-bit signed format.

10.11.7.6 (ID 881) FB Data IN 6

Location in the menu: **V2.12.7.6**

This monitoring value shows the raw value of process data in a 32-bit signed format.

10.11.7.7 (ID 882) FB Data IN 7

Location in the menu: **V2.12.7.7**

This monitoring value shows the raw value of process data in a 32-bit signed format.

10.11.7.8 (ID 883) FB Data IN 8

Location in the menu: **V2.12.7.8**

This monitoring value shows the raw value of process data in a 32-bit signed format.

10.11.7.9 (ID 229) FB Data IN 9

Location in the menu: **V2.12.7.9**

This monitoring value shows the raw value of process data in a 32-bit signed format.

10.11.7.10 (ID 230) FB Data IN 10

Location in the menu: **V2.12.7.10**

This monitoring value shows the raw value of process data in a 32-bit signed format.

10.11.7.11 (ID 231) FB Data IN 11

Location in the menu: **V2.12.7.11**

This monitoring value shows the raw value of process data in a 32-bit signed format.

10.11.7.12 (ID 232) FB Data IN 12

Location in the menu: **V2.12.7.12**

This monitoring value shows the raw value of process data in a 32-bit signed format.

10.11.7.13 (ID 233) FB Data IN 13

Location in the menu: **V2.12.7.13**

This monitoring value shows the raw value of process data in a 32-bit signed format.

10.11.7.14 (ID 234) FB Data IN 14

Location in the menu: **V2.12.7.14**

This monitoring value shows the raw value of process data in a 32-bit signed format.

10.11.7.15 (ID 235) FB Data IN 15

Location in the menu: **V2.12.7.15**

This monitoring value shows the raw value of process data in a 32-bit signed format.

10.11.7.16 (ID 236) FB Data IN 16

Location in the menu: **V2.12.7.16**

This monitoring value shows the raw value of process data in a 32-bit signed format.

10.11.8 Fieldbus Data Out

10.11.8.1 (ID 866) FB Data OUT 1

Location in the menu: **V2.12.8.1**

This monitoring value shows the raw value of process data in a 32-bit signed format.

10.11.8.2 (ID 867) FB Data OUT 2

Location in the menu: **V2.12.8.2**

This monitoring value shows the raw value of process data in a 32-bit signed format.

10.11.8.3 (ID 868) FB Data OUT 3

Location in the menu: **V2.12.8.3**

This monitoring value shows the raw value of process data in a 32-bit signed format.

10.11.8.4 (ID 869) FB Data OUT 4

Location in the menu: **V2.12.8.4**

This monitoring value shows the raw value of process data in a 32-bit signed format.

10.11.8.5 (ID 870) FB Data OUT 5

Location in the menu: **V2.12.8.5**

This monitoring value shows the raw value of process data in a 32-bit signed format.

10.11.8.6 (ID 871) FB Data OUT 6

Location in the menu: **V2.12.8.6**

This monitoring value shows the raw value of process data in a 32-bit signed format.

10.11.8.7 (ID 872) FB Data OUT 7

Location in the menu: **V2.12.8.7**

This monitoring value shows the raw value of process data in a 32-bit signed format.

10.11.8.8 (ID 873) FB Data OUT 8

Location in the menu: **V2.12.8.8**

This monitoring value shows the raw value of process data in a 32-bit signed format.

10.11.8.9 (ID 245) FB Data OUT 9

Location in the menu: **V2.12.8.9**

This monitoring value shows the raw value of process data in a 32-bit signed format.

10.11.8.10 (ID 246) FB Data OUT 10

Location in the menu: **V2.12.8.10**

This monitoring value shows the raw value of process data in a 32-bit signed format.

10.11.8.11 (ID 247) FB Data OUT 11

Location in the menu: **V2.12.8.11**

This monitoring value shows the raw value of process data in a 32-bit signed format.

10.11.8.12 (ID 248) FB Data OUT 12

Location in the menu: **V2.12.8.12**

This monitoring value shows the raw value of process data in a 32-bit signed format.

10.11.8.13 (ID 249) FB Data OUT 13

Location in the menu: **V2.12.8.13**

This monitoring value shows the raw value of process data in a 32-bit signed format.

10.11.8.14 (ID 250) FB Data OUT 14

Location in the menu: **V2.12.8.14**

This monitoring value shows the raw value of process data in a 32-bit signed format.

10.11.8.15 (ID 251) FB Data OUT 15

Location in the menu: **V2.12.8.15**

This monitoring value shows the raw value of process data in a 32-bit signed format.

10.11.8.16 (ID 252) FB Data OUT 16

Location in the menu: **V2.12.8.16**

This monitoring value shows the raw value of process data in a 32-bit signed format.

10.12 Drive Customizer

10.12.1 (ID 15020) Block Out.1

Location in the menu: **V2.13.2**

This monitoring value shows the value of the function block output in the Drive customizer function.

10.12.2 (ID 15040) Block Out.2

Location in the menu: **V2.13.3**

This monitoring value shows the value of the function block output in the Drive customizer function.

10.12.3 (ID 15060) Block Out.3

Location in the menu: **V2.13.4**

This monitoring value shows the value of the function block output in the Drive customizer function.

10.12.4 (ID 15080) Block Out.4

Location in the menu: **V2.13.5**

This monitoring value shows the value of the function block output in the Drive customizer function.

10.12.5 (ID 15100) Block Out.5

Location in the menu: **V2.13.6**

This monitoring value shows the value of the function block output in the Drive customizer function.

10.12.6 (ID 15120) Block Out.6

Location in the menu: **V2.13.7**

This monitoring value shows the value of the function block output in the Drive customizer function.

10.12.7 (ID 15140) Block Out.7

Location in the menu: **V2.13.8**

This monitoring value shows the value of the function block output in the Drive customizer function.

10.12.8 (ID 15160) Block Out.8

Location in the menu: **V2.13.9**

This monitoring value shows the value of the function block output in the Drive customizer function.

10.12.9 (ID 15180) Block Out.9

Location in the menu: **V2.13.10**

This monitoring value shows the value of the function block output in the Drive customizer function.

10.12.10 (ID 15200) Block Out.10

Location in the menu: **V2.13.11**

This monitoring value shows the value of the function block output in the Drive customizer function.

10.13 Condition-based Monitoring

10.13.1 Baseline Data

10.13.1.1 (ID 3601) Baseline Data Element 1

Location in the menu: **V2.16.1.1**

This monitoring value shows the baseline data. The baseline data is selected using the baseline data selector.

10.13.1.2 (ID 3602) Baseline Data Element 2

Location in the menu: **V2.16.1.2**

This monitoring value shows the baseline data. The baseline data is selected using the baseline data selector.

10.13.1.3 (ID 3603) Baseline Data Element 3

Location in the menu: **V2.16.1.3**

This monitoring value shows the baseline data. The baseline data is selected using the baseline data selector.

10.13.1.4 (ID 3604) Baseline Data Element 4

Location in the menu: **V2.16.1.4**

This monitoring value shows the baseline data. The baseline data is selected using the baseline data selector.

10.13.1.5 (ID 3605) Baseline Data Element 5

Location in the menu: **V2.16.1.5**

This monitoring value shows the baseline data. The baseline data is selected using the baseline data selector.

10.13.1.6 (ID 3606) Baseline Data Element 6

Location in the menu: **V2.16.1.6**

This monitoring value shows the baseline data. The baseline data is selected using the baseline data selector.

10.13.1.7 (ID 3607) Baseline Data Element 7

Location in the menu: **V2.16.1.7**

This monitoring value shows the baseline data. The baseline data is selected using the baseline data selector.

10.13.1.8 (ID 3608) Baseline Data Element 8

Location in the menu: **V2.16.1.8**

This monitoring value shows the baseline data. The baseline data is selected using the baseline data selector.

10.13.1.9 (ID 3609) Baseline Data Element 9

Location in the menu: **V2.16.1.9**

This monitoring value shows the baseline data. The baseline data is selected using the baseline data selector.

10.13.1.10 (ID 3610) Baseline Data Element 10

Location in the menu: **V2.16.1.10**

This monitoring value shows the baseline data. The baseline data is selected using the baseline data selector.

10.13.1.11 (ID 3622) Baseline Run Status

Location in the menu: **V2.16.1.11**

This monitoring value shows the baseline run status.

10.13.2 Stator Winding Monitor

10.13.2.1 (ID 3617) Current Unbalance

Location in the menu: **V2.16.2.1**

This monitoring value shows the current unbalance when condition-based monitoring is activated.

10.13.2.2 (ID 3620) Current Unbalance Threshold Value

Location in the menu: **V2.16.2.2**

This monitoring value shows the threshold value after interpolating.

10.13.2.3 (ID 3611) Current Warning S1 High Threshold

Location in the menu: **V2.16.2.3**

This monitoring value shows the warning S1 high threshold value.

10.13.2.4 (ID 3612) Current Warning S2 High Threshold

Location in the menu: **V2.16.2.4**

This monitoring value shows the warning S2 high threshold value.

10.13.2.5 (ID 3613) Current Alarm High Threshold

Location in the menu: **V2.16.2.5**

This monitoring value shows the alarm/fault high threshold value.

10.13.3 Vibration

10.13.3.1 (ID 3623) Vibration

Location in the menu: **V2.16.3.1**

This monitoring value shows the vibration when condition-based monitoring is activated.

10.13.3.2 (ID 3624) Vibration Threshold Value

Location in the menu: **V2.16.3.2**

This monitoring value shows the threshold value after interpolating.

10.13.3.3 (ID 3625) Vibration S1 High Threshold

Location in the menu: **V2.16.3.3**

This monitoring value shows the warning S1 high threshold value.

10.13.3.4 (ID 3626) Vibration S2 High Threshold

Location in the menu: **V2.16.3.4**

This monitoring value shows the warning S2 high threshold value.

10.13.3.5 (ID 3627) Vibration Alarm High Threshold

Location in the menu: **V2.16.3.5**

This monitoring value shows the alarm/fault high threshold value.

10.13.4 Load

10.13.4.1 (ID 3628) Load Threshold Value

Location in the menu: **V2.16.4.2**

This monitoring value shows the threshold value after interpolating.

10.13.4.2 (ID 3629) Load S1 High Threshold

Location in the menu: **V2.16.4.3**

This monitoring value shows the warning S1 high threshold value.

10.13.4.3 (ID 3630) Load S2 High Threshold

Location in the menu: **V2.16.4.4**

This monitoring value shows the warning S2 high threshold value.

10.13.4.4 (ID 3631) Load Alarm High Threshold

Location in the menu: **V2.16.4.5**

This monitoring value shows the alarm/fault high threshold value.

10.13.4.5 (ID 3632) Load S1 Low Threshold

Location in the menu: **V2.16.4.6**

This monitoring value shows the warning S1 low threshold value.

10.13.4.6 (ID 3633) Load S2 Low Threshold

Location in the menu: **V2.16.4.7**

This monitoring value shows the warning S2 low threshold value.

10.13.4.7 (ID 3634) Load Alarm Low Threshold

Location in the menu: **V2.16.4.8**

This monitoring value shows the alarm/fault low threshold value.

10.13.5 (ID 3619) Condition-based Monitoring Status

Location in the menu: **V2.16.5**

This monitoring value shows the fault status of the condition-based monitoring.

11 Parameter descriptions

11.1 (ID 212) Application

Location in the menu: **P1.2**

Use this parameter to select the application configuration for the drive. The applications include preset application configurations, that is, sets of predefined parameters. The selection of the application makes the commissioning of the drive easy and reduces the manual work with the parameters.

⚠ WARNING ⚠

ACCIDENTAL START BECAUSE OF CHANGE OF SETTINGS

Running the Startup wizard, changing the application or the software can cause the I/O functions to change.

- Disconnect the motor from the drive if an accidental start can be dangerous.

When the value of this parameter changes, a parameter groups get their preset values. The value of this parameter can be changed when the starting up or commissioning the drive.

If this parameter is changed in the control panel, an application wizard starts and helps to set the basic parameters related to the application. The wizard does not start, when using the PC tool to change this parameter. For more data about the application wizards, see [4.1 Application Wizards](#).

These applications are available:

- 0 = Standard
- 1 = Local/Remote
- 2 = Multi-step speed
- 3 = PID control
- 4 = Multi-purpose
- 5 = Motor potentiometer

NOTICE

When the application is changed, the contents of the Quick Setup menu change.

11.2 Trend Curve

11.2.1 (ID 2368) Sampling Interval

Location in the menu: **P2.2.2**

Use this parameter to set the sampling interval.

11.2.2 (ID 2369) Channel 1 MIN

Location in the menu: **P2.2.3**

This parameter is used in scaling by default. Adjustments can be necessary.

11.2.3 (ID 2370) Channel 1 MAX

Location in the menu: **P2.2.4**

This parameter is used in scaling by default. Adjustments can be necessary.

11.2.4 (ID 2371) Channel 2 MIN

Location in the menu: **P2.2.5**

This parameter is used in scaling by default. Adjustments can be necessary.

11.2.5 (ID 2372) Channel 2 MAX

Location in the menu: **P2.2.6**

This parameter is used in scaling by default. Adjustments can be necessary.

11.2.6 (ID 2373) Autoscale

Location in the menu: **P2.2.7**

Use this parameter to set autoscaling on or off. If autoscaling is enabled, the signal is automatically scaled between the minimum and maximum values.

11.3 Fieldbus Redundancy

11.3.1 (ID 2606) Redundancy Mode

Location in the menu: **P5.13.3.1**

Use this parameter to select the mode for the fieldbus redundancy control.

11.3.2 (ID 2607) Primary Fieldbus Connection

Location in the menu: **P5.13.3.2**

Use this parameter to select the primary controlling fieldbus connection.

11.3.3 (ID 2608) Secondary Fieldbus Connection

Location in the menu: **P5.13.3.3**

Use this parameter to select the secondary controlling fieldbus connection.

11.3.4 (ID 2609) Switchover Timeout

Location in the menu: **P5.13.3.4**

Use this parameter to set a timeout delay for switching over from the current fieldbus connection to another connection when current fieldbus fails.

11.3.5 (ID 2612) Switchback Timeout

Location in the menu: **P5.13.3.5**

Use this parameter to set a timeout delay for switching back from the secondary fieldbus connection to the primary connection. If the value of this parameter is zero, the controlling fieldbus connection is not changed until it is failing.

11.3.6 (ID 2611) Switchover Counter

Location in the menu: **V5.13.3.6**

This monitoring value shows the number of times the redundancy logic has changed the controlling fieldbus. The value is reset when the redundant control is disabled.

11.4 Motor Settings

11.4.1 Motor Nameplate Parameters

11.4.1.1 (ID 110) Motor Nominal Voltage

Location in the menu: **P3.1.1.1**

Find the value U_n on the nameplate of the motor. Find out whether the motor connection is Delta or Star.

11.4.1.2 (ID 111) Motor Nominal Frequency

Location in the menu: **P3.1.1.2**

Find the value f_n on the nameplate of the motor.

When this parameter changes, parameters *P3.1.4.2 Field Weakening Point Frequency* and *P3.1.4.3 Voltage at Field Weakening Point* start automatically. The 2 parameters have different values for each motor type. See [11.4.2.2 \(ID 650\) Motor Type](#).

11.4.1.3 (ID 112) Motor Nominal Speed

Location in the menu: **P3.1.1.3**

Find the value n_n on the nameplate of the motor.

11.4.1.4 (ID 113) Motor Nominal Current

Location in the menu: **P3.1.1.4**

Find the value I_n on the nameplate of the motor.

11.4.1.5 (ID 120) Motor Cos Phi

Location in the menu: **P3.1.1.5**

Find the value on the nameplate of the motor.

11.4.1.6 (ID 116) Motor Nominal Power

Location in the menu: **P3.1.1.6**

Find the value P_n on the nameplate of the motor.

11.4.2 Motor Control Parameters

11.4.2.1 (ID 600) Control Mode

Location in the menu: **P3.1.2.1**

Use this parameter to set the AC drive control mode.

Selection number	Selection name	Description
0	Frequency control	The frequency reference of the drive is set to the output frequency without slip compensation. The actual speed of the motor is specified by the motor load.
1	Speed control	The frequency reference of the drive is set to the motor speed reference. The motor load does not have an effect on the motor speed. There is slip compensation.
2	Torque control	The motor torque is controlled. The motor produces torque in the set speed limits to achieve torque reference. P3.3.2.7 (Torque Control Frequency Limit) controls the motor speed limit.

11.4.2.2 (ID 650) Motor Type

Location in the menu: **P3.1.2.2**

Use this parameter to set the type of motor in the process.

Selection number	Selection name	Description
0	Induction motor (IM)	Make this selection if an induction motor is in use.
1	Permanent Magnet Motor (PM)	Make this selection if permanent magnet motor is in use.
2	Reluctance Motor	Make this selection if a reluctance motor is in use.

When the value of parameter P3.1.2.2 Motor Type is changed, the values of parameters P3.1.4.2 Field Weakening Point Frequency and P3.1.4.3 Voltage at Field Weakening Point change automatically. See the following table. The 2 parameters have different values for each motor type.

Parameter	Induction motor (IM)	Permanent magnet motor (PM)
P3.1.4.2 (Field Weakening Point Frequency)	Motor nominal frequency	Internally calculated
P3.1.4.3 (Voltage at Field Weakening Point)	100.0%	Internally calculated

See [11.28 Settings for Different Motor Types](#) for more information.

11.4.2.3 (ID 601) Switching Frequency

Location in the menu: **P3.1.2.3**

Use this parameter to set the switching frequency of the AC drive.

If the switching frequency is increased, the capacity of the AC drive reduces. To reduce capacitive currents in the motor cable, when the cable is long, we recommend using a low switching frequency. To reduce the motor noise, use a high switching frequency.

11.4.2.4 (ID 631) Identification

Location in the menu: **P3.1.2.4**

Use this parameter to find the parameter values that are optimal for the operation of the drive.

The identification run calculates or measures the motor parameters that are necessary for a good control of the motor and speed.

The identification run helps to adjust the motor-specific and the drive-specific parameters. It is a tool for the commissioning and the servicing of the drive.

N O T I C E

Before the identification run, set the motor nameplate parameters.

Selection number	Selection name	Description
0	No action	No identification requested.
1	Identification at standstill	The drive operates without speed when doing the identification run for the motor parameters. The motor receives current and voltage, but the frequency is zero. The U/f ratio and start magnetization parameters are identified.
2	Identification with rotation	The drive operates with speed when doing the identification run for the motor parameters. The U/f ratio, the magnetization current and start magnetization parameters are identified. To get accurate results, do this identification run with no load on the motor shaft.

To activate the Identification function, set the parameter P3.1.2.4 and give a start command. The start command must be given in 20 s. If there is no start command in that time, the identification run does not start. The parameter P3.1.2.4 is reset to the default value and an identification alarm shows.

To stop the identification run before it is completed, give a stop command. This resets the parameter to the default value. If the identification run is not completed, an identification alarm shows.

N O T I C E

To start the drive after the identification, a new start command is necessary.

11.4.2.5 (ID 612) Magnetizing Current

Location in the menu: **P3.1.2.5**

Use this parameter to set the magnetizing current of the motor.

The magnetizing current (no-load current) of the motor identifies the values of the U/f parameters when they are given before the identification run. If the value is set to 0, the magnetizing current is calculated internally.

11.4.2.6 (ID 653) Motor Switch

Location in the menu: **P3.1.2.6**

Use this parameter to enable the Motor Switch function. Use the Motor Switch function, if the cable that connects the motor and the drive has a motor switch. The operation of the motor switch makes sure that the motor is isolated from the voltage source and does not start during the servicing.

To activate the function, set the parameter P3.1.2.6 to the value Enabled. The drive stops automatically when the motor switch is opened, and the drive starts automatically when the motor switch is closed. The drive does not trip when using the Motor switch function.

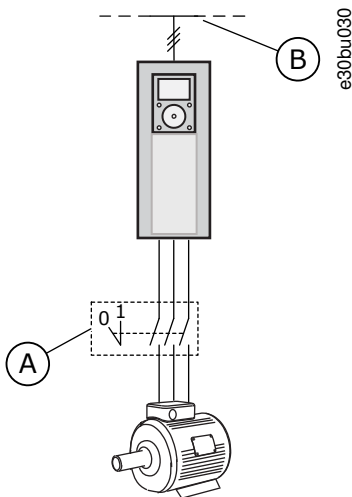

Illustration 18: The Motor Switch Between the Drive and the Motor

A	The motor switch
B	Mains

11.4.2.7 (ID 620) Load Drooping

Location in the menu: **P3.1.2.7**

Use this parameter to enable the Load Drooping function. The Load drooping function enables a speed drop as a function of load. Use this function when a balanced load is necessary for mechanically connected motors. This is called static drooping. The function can also be used when a dynamic drooping is necessary because the load changes. In static drooping, the Load Drooping Time is set to 0, so that the drooping cannot decay. In dynamic drooping, the Load Drooping Time is set. The load is momentarily drooped with energy from the system inertia. This decreases the current torque spikes when the load changes suddenly.

If the motor has a nominal frequency of 50 Hz, the motor is loaded with the nominal load (100% of the torque), and Load Drooping is set to 10%, the output frequency is let to decrease 5 Hz from the frequency reference.

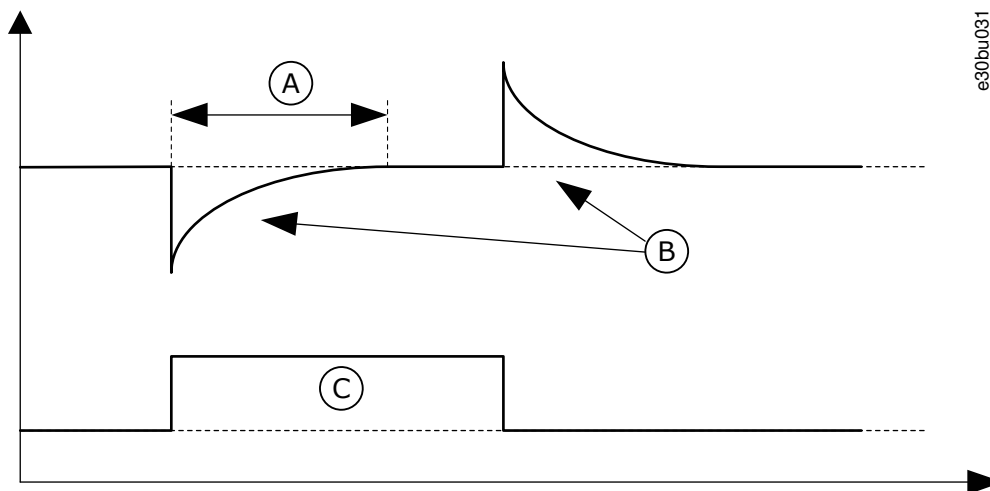

Illustration 19: The Load Drooping Function

A	Load Drooping Time (ID 656)	C	Torque
B	Output Frequency		

11.4.2.8 (ID 656) Load Drooping Time

Location in the menu: **P3.1.2.8**

Use this parameter to set the drooping time of the motor. Use load drooping to get a dynamic speed drooping when the load changes. This parameter gives the time during which the speed is restored 63% of the change.

11.4.2.9 (ID 1534) Load Drooping Mode

Location in the menu: **P3.1.2.9**

Use this parameter to set the load drooping mode.

Selection number	Selection name	Description
0	Normal	The load drooping factor is constant through the frequency range.
1	Linear removal	The load drooping is removed linearly from the nominal frequency to zero frequency.

11.4.2.10 (ID 607) Overvoltage Control

Location in the menu: **P3.1.2.10**

Use this parameter to set the overvoltage controller out of operation.

The function is necessary when

- the supply voltage changes, for example, between -15% and +10%, and
- the controlled process does not have the tolerance for the changes that the undervoltage controller and the overvoltage controller make to the output frequency of the drive.

The overvoltage controller increases the output frequency of the drive

- to keep the DC link voltage in the permitted limits, and
- to make sure that the drive does not trip because of an overvoltage fault.

N O T I C E

The drive can trip when the overvoltage and undervoltage controllers are disabled.

11.4.2.11 (ID 608) Undervoltage Control

Location in the menu: **P3.1.2.11**

Use this parameter to set the undervoltage controller out of operation.

The function is necessary when

- the supply voltage changes, for example, between -15% and +10%, and
- the controlled process does not have the tolerance for the changes that the undervoltage controller and the overvoltage controller make to the output frequency of the drive.

The undervoltage controller decreases the output frequency of the drive

- to get energy from the motor to keep the DC-link voltage at a minimum level when the voltage is near the lowest permitted limit, and
- to make sure that the drive does not trip because of an undervoltage fault.

N O T I C E

The drive can trip when the overvoltage and undervoltage controllers are disabled.

11.4.2.12 (ID 666) Energy Optimization

Location in the menu: **P3.1.2.12**

Use this parameter to enable the Energy Optimization function. To save energy and to lower the motor noise, the drive searches for the minimum motor current. Use this function, for example in fan and pump processes. Do not use the function with fast PID controlled processes.

11.4.2.13 (ID 659) Stator Voltage Adjust

Location in the menu: **P3.1.2.13**

Use this parameter to adjust the stator voltage in permanent magnet motors.

NOTICE

The identification run sets a value for this parameter automatically. We recommend the identification run, if it is possible. Make the identification run with the parameter P3.1.2.4.

It is possible to use this parameter only when the parameter P3.1.2.2 Motor Type has the value PM motor. If induction motor is selected as the motor type, the value is automatically set to 100%, and the value cannot be changed.

When changing the value of P3.1.2.2 (Motor type) to PM Motor, the parameters P3.1.4.2 (Field Weakening Point Frequency) and P3.1.4.3 (Voltage at Field Weakening Point) increase automatically to be equal with output voltage of the drive. The set U/f ratio does not change. This is done to prevent the operation of the PM motor in the field weakening area. The nominal voltage of the PM motor is much lower than the full output voltage of the drive.

The nominal voltage of the PM motor agrees to the back EMF voltage of the motor at nominal frequency. But in a different motor manufacturer, it can be equal to, for example, the stator voltage at nominal load.

Stator Voltage Adjust helps to adjust the U/f curve of the drive near the back EMF curve. It is not necessary to change the values of many U/f curve parameters.

The parameter P3.1.2.13 gives the output voltage of the drive in percentage of the nominal voltage of the motor at the nominal frequency of the motor. Adjust the U/f curve of the drive above the back EMF curve. The motor current increases the more the U/f curve is different from the back EMF curve.

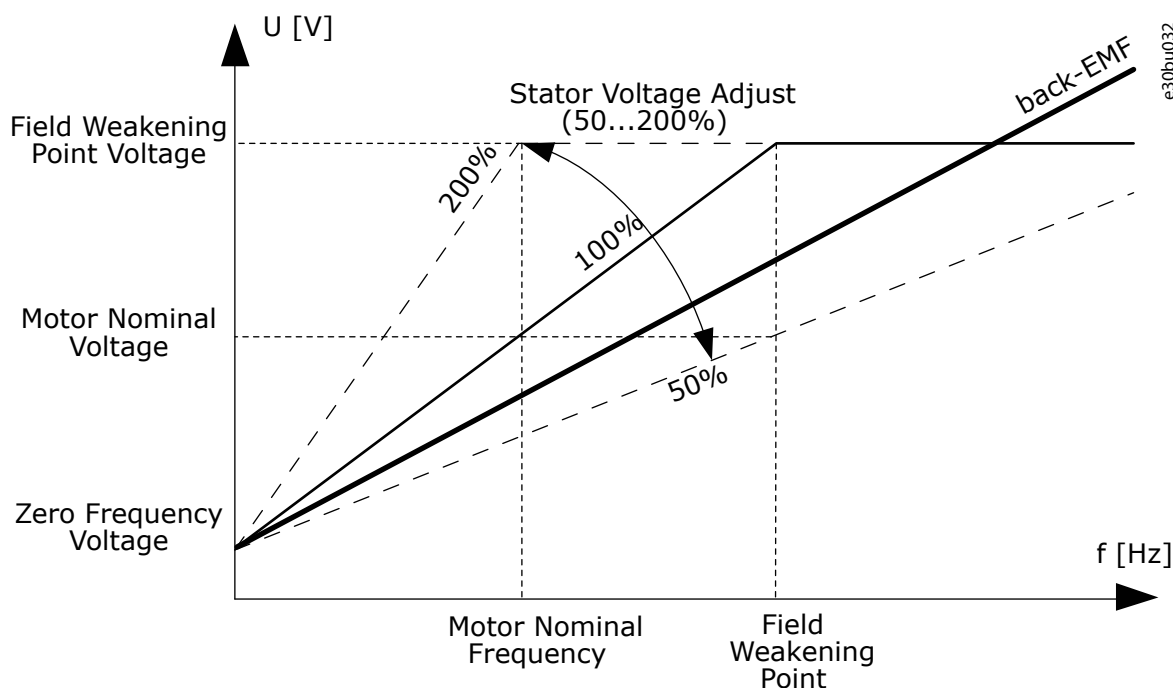

Illustration 20: The Stator Voltage Adjustment

11.4.2.14 (ID 1515) Overmodulation

Location in the menu: P3.1.2.14

Use this parameter to disable the overmodulation of the AC drive. Overmodulation maximizes the output voltage of the drive, but increases the motor current harmonics.

11.4.2.15 (ID 662) Stator Resistance Voltage Drop

Location in the menu: P3.1.2.15

Use this parameter to set the motor stator phase-resistance value (in star-connection equivalent circuit). The resistance is essential for an accurate motor control.

The value is given as a percentage of voltage drop at nominal current.

N O T I C E

The identification run sets a value for this parameter automatically. We recommend the identification run, if it is possible. Make the identification run with the parameter P3.1.2.4.

11.4.2.16 (ID 673) Stator Inductance Voltage Drop

Location in the menu: **P3.1.2.16**

Use this parameter to set the motor stator phase-inductance value (in star-connection equivalent circuit). The value is the transient inductance (for induction motors) or the line-to-neutral inductance (for permanent magnet and reluctance motors).

The value is given as a percentage of voltage drop at nominal current and nominal frequency.

N O T I C E

The identification run sets a value for this parameter automatically. We recommend the identification run, if it is possible. Make the identification run with the parameter P3.1.2.4.

11.4.2.17 (ID 674) Motor BEM Voltage

Location in the menu: **P3.1.2.17**

Use this parameter to set the back electromotive force (back EMF) voltage of a permanent magnet motor. The value of this parameter is the motor terminal voltage when the motor current is zero.

The value is given as line-to-line RMS voltage at nominal operating frequency. Identification at standstill uses this parameter to set U/f curve in open loop control mode. The back EMF value that is identified in Identification with rotation overwrites the existing parameter value.

11.4.3 Motor Limits

11.4.3.1 (ID 107) Motor Current Limit

Location in the menu: **P3.1.3.1**

Use this parameter to set the maximum motor current from the AC drive. The range of values for the parameter is different for each enclosure size of the drive.

When the current limit is active, the drive output frequency decreases.

N O T I C E

The Motor Current Limit is not an overcurrent trip limit.

11.4.3.2 (ID 1287) Motor Torque Limit

Location in the menu: **P3.1.3.2**

Use this parameter to set the maximum torque limit of the motoring side.

The range of values for the parameter is different for each enclosure size of the drive.

11.4.3.3 (ID 1288) Generator Torque Limit

Location in the menu: **P3.1.3.3**

Use this parameter to set the maximum torque limit of the generating side.

The range of values for the parameter is different for each enclosure size of the drive.

11.4.3.4 (ID 1289) Motor Power Limit

Location in the menu: **P3.1.3.4**

Use this parameter to set the maximum power limit of the motoring side.

The range of values for the parameter is different for each enclosure size of the drive.

11.4.3.5 (ID 1290) Generator Power Limit

Location in the menu: **P3.1.3.5**

Use this parameter to set the maximum power limit of the generating side.

The range of values for the parameter is different for each enclosure size of the drive.

11.4.4 Open Loop Parameters

11.4.4.1 (ID 108) U/F Ratio

Location in the menu: P3.1.4.1

Use this parameter to set the type of the U/f curve between zero frequency and the field weakening point.

Selection number	Selection name	Description
0	Linear	The voltage of the motor changes linearly as a function of the output frequency. The voltage changes from the value of P3.1.4.6 (Zero Frequency Voltage) to the value of P3.1.4.3 (Voltage at Field Weakening Point) at a frequency set in P3.1.4.2 (Field Weakening Point Frequency). Use this default setting if a different setting is not necessary.
1	Squared	The voltage of the motor changes from the value of P3.1.4.6 (Zero Frequency Voltage) to the value of P3.1.4.2 (Field Weakening Point Frequency) at a squared curve. The motor operates undermagnetized below the field weakening point and produces less torque. Use the squared U/f ratio in applications where the torque demand is in relation to the square of the speed, for example in centrifugal fans and pumps.
2	Programmable	It is possible to program the U/f curve with 3 different points: the zero frequency voltage (P1), the mid-point voltage/ frequency (P2), and the field weakening point (P3). Use the programmable U/f curve at low frequencies if it is necessary to have more torque. Use the identification run (P3.1.2.4) to find the optimal settings automatically.

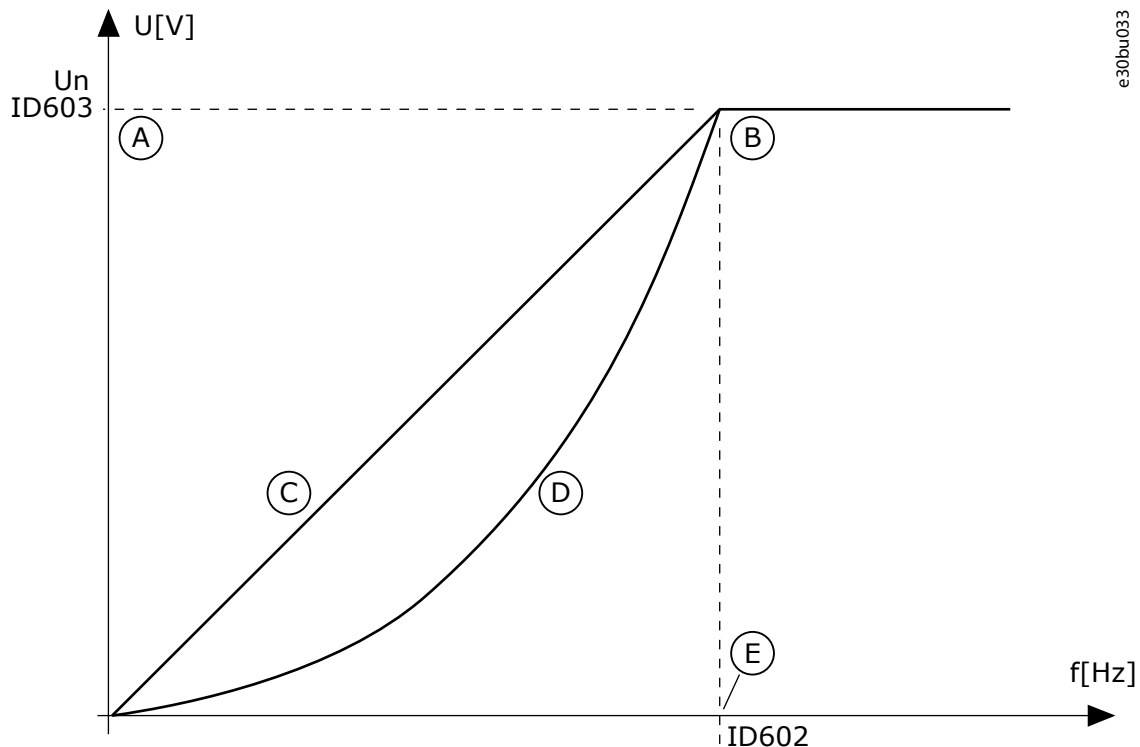

Illustration 21: Linear and Squared Change of the Motor Voltage

A	Default: Nominal voltage of the motor	D	Squared
B	Field weakening point	E	Default: Nominal frequency of the motor
C	Linear		

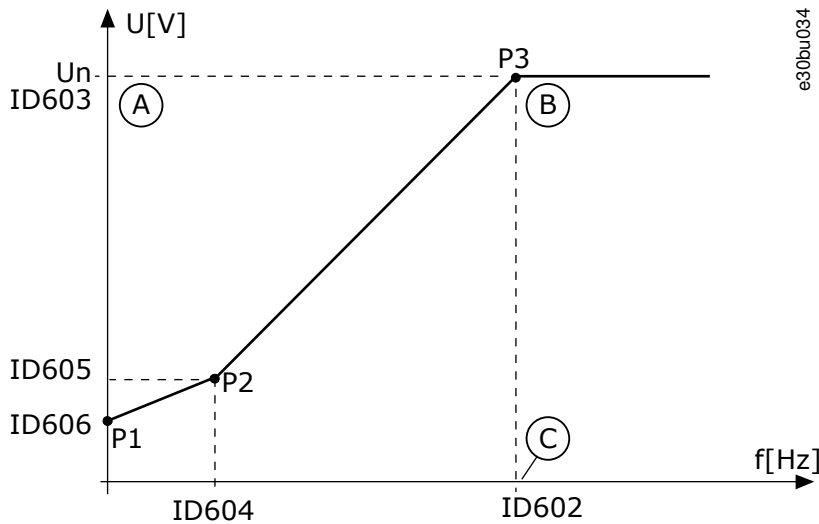

Illustration 22: The Programmable U/f Curve

A	Default: Nominal voltage of the motor	C	Default: Nominal frequency of the motor
B	Field weakening point		

When the parameter Motor Type has the value PM motor (Permanent Magnet Motor), this parameter is automatically set to the value Linear.

When the parameter Motor Type has the value Induction Motor, and when this parameter is changed, these parameters are set to their default values:

- P3.1.4.2 Field Weakening Point Frequency
- P3.1.4.3 Voltage at Field Weakening Point
- P3.1.4.4 U/f Midpoint Frequency
- P3.1.4.5 U/f Midpoint Voltage
- P3.1.4.6 Zero Frequency Voltage

11.4.4.2 (ID 602) Field Weakening Point Frequency

Location in the menu: **P3.1.4.2**

Use this parameter to set the output frequency at which the output voltage reaches the field weakening point voltage.

11.4.4.3 (ID 603) Voltage at Field Weakening Point

Location in the menu: **P3.1.4.3**

Use this parameter to set the voltage at the field weakening point as a percentage of the motor nominal voltage.

Above the frequency at the field weakening point, the output voltage stays at the set maximum value. Below the frequency at the field weakening point, the U/f curve parameters control the output voltage. See the U/f parameters P3.1.4.1, P3.1.4.4 and P3.1.4.5.

When setting the parameters P3.1.1.1 (Motor nominal voltage) and P3.1.1.2 (Motor nominal frequency), the parameters P3.1.4.2 and P3.1.4.3 automatically receive related values. To have different values for P3.1.4.2 and P3.1.4.3, change these parameters only after setting the parameters P3.1.1.1 and P3.1.1.2.

11.4.4.4 (ID 604) U/f Midpoint Frequency

Location in the menu: **P3.1.4.4**

Use this parameter to set the middle point frequency of the U/f curve.

NOTICE

This parameter gives the middle point frequency of the curve if the value of P3.1.4.1 is programmable.

11.4.4.5 (ID 605) U/f Midpoint Voltage

Location in the menu: **P3.1.4.5**

Use this parameter to set the middle point voltage of the U/f curve.

NOTICE

This parameter gives the middle point voltage of the curve if the value of P3.1.4.1 is programmable.

11.4.4.6 (ID 606) Zero Frequency Voltage

Location in the menu: **P3.1.4.6**

Use this parameter to set the zero frequency voltage of the U/f curve. The default value for the parameter is different for each unit size.

11.4.4.7 (ID 1590) Flying Start Options

Location in the menu: **P3.1.4.7**

Use this parameter to set the flying start options. The parameter Flying Start Options has a checkbox selection of values.

The bits can receive these values.

- Search the shaft frequency only from the same direction as the frequency reference
- Disable the AC scanning
- Use the frequency reference for an initial guess
- Disable the DC pulses
- Flux build with current control

The bit B0 controls the search direction. With the bit set to 0, the shaft frequency is searched in 2 directions, the positive and the negative. With the bit set to 1, the shaft frequency is searched only in the frequency reference direction. It prevents the shaft movements for the other direction.

The bit B1 controls the AC scanning that premagnetizes the motor. In the AC scanning, the system sweeps the frequency from the maximum towards zero frequency. The AC scanning stops when an adaptation to the shaft frequency occurs. To disable the AC scanning, set the bit B1 to 1. If the value of Motor Type is permanent magnet motor, the AC scanning is disabled automatically.

Use the bit B5 to disable the DC pulses. The primary function of the DC pulses is to premagnetize the motor and examine the rotation of the motor. If the DC pulses and the AC scanning are enabled, the slip frequency tells which procedure is applied. If the slip frequency is less than 2 Hz, or the motor type is PM motor, the DC pulses are disabled automatically.

The bit B7 controls the rotation direction of the injected high frequency signal, which is used in the flying start of synchronous reluctance machines. Signal injection is used to detect the frequency of the rotor. If the rotor is in a blind angle when the signal is injected, the rotor frequency is undetectable. Reversing the rotation direction of the injection signal solves this problem.

11.4.4.8 (ID 1610) Flying Start Scan Current

Location in the menu: **P3.1.4.8**

Use this parameter to set the flying start scan current as a percentage of the motor nominal current.

11.4.4.9 (ID 109) Automatic Torque Boost

Location in the menu: **P3.1.4.9**

Use this parameter with a process that has a high starting torque because of friction.

The voltage to the motor changes in relation to the necessary torque. It makes the motor give more torque at the start and when the motor operates at low frequencies.

The torque boost affects the linear U/f curve. For the best result, do the identification run and activate the programmable U/f curve.

11.4.4.10 (ID 667) Torque Boost Motor Gain

Location in the menu: **P3.1.4.10**

Use this parameter to set the scaling factor for the motoring side IR-compensation when the torque boost is used.

11.4.4.11 (ID 665) Torque Boost Generator Gain

Location in the menu: **P3.1.4.11**

Use this parameter to set the scaling factor for the generating side IR-compensation when the torque boost is used.

11.4.5 I/f Start Function

With a PM motor, use the I/f Start function to start the motor with constant current control. A high power motor gives the best effect. With a high power motor, the resistance is low and it is not easy to change the U/f curve.

The I/f Start function can also give a sufficient torque for the motor at start up.

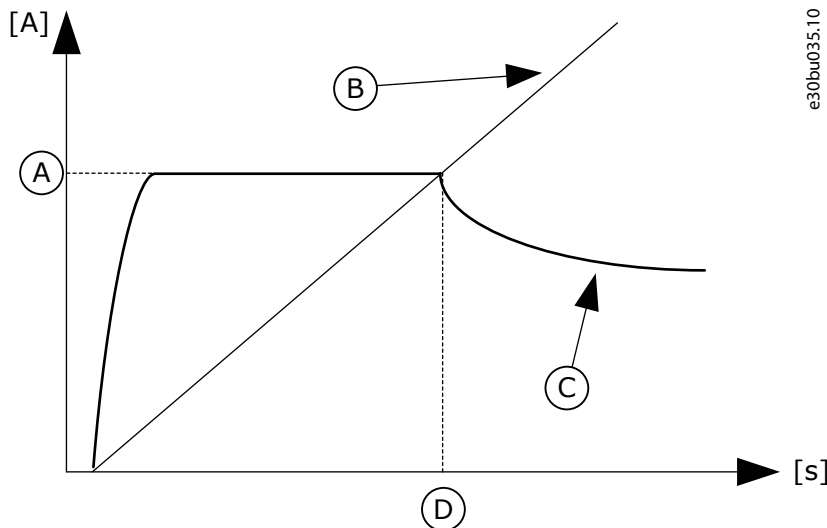

Illustration 23: The I/f Start Parameters

A	I/f Start Current	C	Motor Current
B	Output Frequency	D	I/f Start Frequency

11.4.5.1 (ID 534) I/f Start

Location in the menu: **P3.1.4.12.1**

Use this parameter to enable the I/f start function.

When the I/f start function is activated, the drive starts to operate in the current control mode. A constant current is led to the motor until the output frequency increases above the level that is set in P3.1.4.12.2. When the output frequency increases above I/f Start Frequency level, the operation mode changes back to the normal U/f control mode.

11.4.5.2 (ID 535) I/f Start Frequency

Location in the menu: **P3.1.4.12.2**

Use this parameter to set the output frequency limit below which the set I/f start current is fed to motor.

When the output frequency of the drive is below the limit of this parameter, I/f start function activates. When the output frequency is more than the limit, the drive operation mode changes back to the normal U/f control mode.

11.4.5.3 (ID 536) I/f Start Current

Location in the menu: **P3.1.4.12.3**

Use this parameter to set the current that is used when the I/f start function is enabled.

11.4.6 Torque Stabilator Function

11.4.6.1 (ID 1412) Torque Stabilator Gain

Location in the menu: **P3.1.4.13.1**

Use this parameter to set the gain of the torque stabilator in an open loop control operation.

11.4.6.2 (ID 1414) Torque Stabilator Gain at Field Weakening Point

Location in the menu: **P3.1.4.13.2**

Use this parameter to set the gain of the torque stabilator at field weakening point in an open loop control operation. The torque stabilizer stabilizes the possible oscillations in the estimated torque.

Two gains are used. TorqStabGainFWP is a constant gain at all the output frequencies. TorqStabGain changes linearly between the zero frequency and the field weakening point frequency. The full gain is at 0 Hz and the gain is zero at the field weakening point. The figure shows the gains as a function of output frequency.

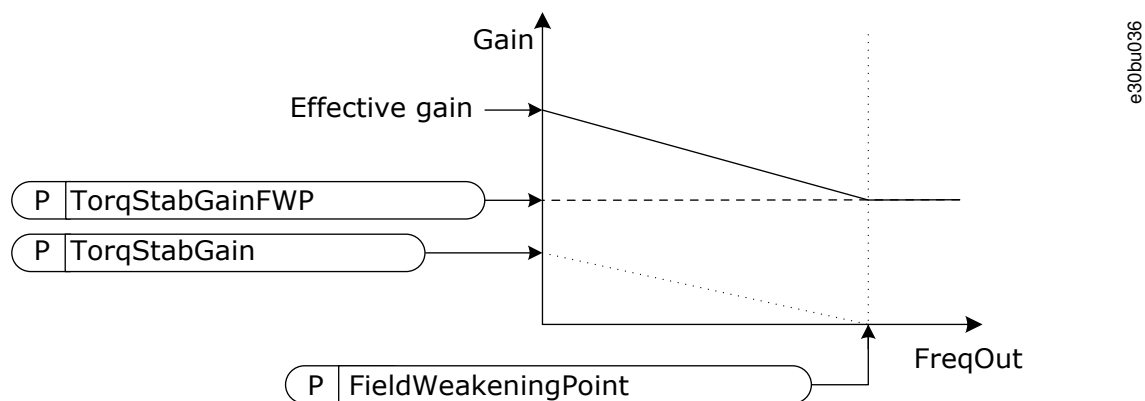

Illustration 24: The Torque Stabilator Gain

11.4.6.3 (ID 1413) Torque Stabilator Damping Time Constant

Location in the menu: **P3.1.4.13.3**

Use this parameter to set the damping time constant of the torque stabilizer.

11.4.6.4 (ID 1735) Torque Stabilator Damping Time Constant for PM Motors

Location in the menu: **P3.1.4.13.4**

Use this parameter to set the damping time constant of the torque stabilizer for permanent magnet or reluctance motors.

11.4.6.5 (ID 15650) Torque Stabilator Filter Time Constant

Location in the menu: **P3.1.4.13.5**

Use this parameter to set the lowpass filtering time constant of the torque stabilizer.

11.4.6.6 (ID 15651) Torque Stabilator Filter Time Constant for PM Motors

Location in the menu: **P3.1.4.13.6**

Use this parameter to set the lowpass filtering time constant of the torque stabilizer for permanent magnet or reluctance motors.

11.4.7 Advanced Sensorless Control

Use the advanced sensorless control function in applications where good speed accuracy or high performance at low speed is necessary, but encoder speed feedback is not used. With the advanced sensorless control, a simple closed loop motor control can be replaced with a high-performance open loop motor control. An example of a possible application is an extruder.

The advanced sensorless control function is not supported when a sine filter, a harmonic filter, or a synchronous reluctance motor is used.

This control mode is sensitive about accurate motor parameterization and requires expert knowledge in the commissioning. We strongly recommend NOT enabling this mode for regular open loop motor control applications or when expert knowledge is not available.

The advanced sensorless control has a similar control structure to the closed loop control but with Voltage Vector Control. The selection between frequency, speed, and torque control is still done with P3.1.2.1 Control Mode.

When commissioning the sensorless control function, always do these steps:

- Do identification with rotation (P1.15/P3.1.2.4 = 2).
- Set reasonable minimum frequencies (P3.3.1.1-3.3.1.4).
- Use motor stall protection (P3.9.3.1-3.9.3.4).

With an induction motor, always use start magnetization to build up rotor flux. With a PM motor, using start magnetization is highly recommended to make sure that the rotor alignment is correct.

The identification with rotation is necessary because the advanced sensorless control is sensitive about accurate motor parameterization. We recommend using minimum frequencies because continuous operation at or near zero frequency can cause instability of control and must be prevented. The motor stall protection function protects the motor if there is instability at low frequency that can cause continuous high current that increases the motor temperature.

In the speed control mode with an induction motor, especially the generator side must be considered because the flux frequency is smaller than the shaft frequency because of the slip frequency.

N O T I C E

The characteristics of the application affect the optimal settings of the control mode parameters.

11.4.7.1 (ID 1724) Sensorless Control

Location in the menu: **P3.1.6.1**

Use this parameter to enable the sensorless control function.

11.4.7.2 (ID 1726) Sensorless Control Options

Location in the menu: **P3.1.6.3**

Use this parameter to set the options of the advanced sensorless control. The parameter has a checkbox selection of values.

Selection number	Selection name	Description
B0	Stator resistance identification	Identify the stator resistance during the start magnetization.
B3	Limit frequency polarity	
B6	Enable IR compensation adjustment	
B8	Voltage-based current limit	
B14	Ramp anti-windup	Use the ramp anti-windup control.

Bit B0

The bit B0 enables stator resistance identification at each start. It is recommended when a start is always made from standstill. It cannot be used when a start is made to a rotating motor.

The temperature affects the stator resistance value. A correct resistance value is necessary for the advanced sensorless control, especially at low frequencies. The temperature effect is mitigated, when instead of using a value that was identified in the first identification run, the resistance is identified at each start.

With the bit set to 1, the stator resistance is identified during the start magnetization. Enable the start magnetization function with *P3.4.3.1 Start Magnetizing Current* and *P3.4.3.2 Start Magnetizing Time*. For induction motors, start magnetizing is already enabled when the identification run is made.

Bit B3

Bit B3 can be used to improve the robustness in applications that require high torque at low speeds but that do not require speed reversals with full load and also do not operate with substantial load on the generator side at low frequencies. An example of a suitable application is an extruder.

When selecting bit B3, the sign (+ or -) of the output frequency is limited according to the sign of the user frequency reference.

When positive frequency reference is used, the output frequency is limited to positive values. When negative frequency reference is used, only negative output frequency is allowed. As a result, the operation is limited in an area where any parameter fault has the most significant effect. It improves the robustness of the control.

Bit B6

Bit B6 is targeted to enable robustness improvement in applications that do not require high torque at low frequencies. The selection is only suitable for applications that do not operate on the generator side.

When bit B6 is activated, the IR compensation can be adjusted in the same way as in a normal open loop control using parameter *P3.1.4.10 Torque Boost Motor Gain*. When the gain value is reduced, sensitivity against parameter faults is also reduced and robustness is improved. Reducing the gain value also reduces torque capability at low frequencies.

Bit B8

Bit B8 activates a function that reduces the risk of the control system getting stuck in the current limit at low frequencies by limiting the motor voltage. It could occur because of errors in the parameter settings. The function is active only when the output frequency is less than 1.0 Hz.

Use the bit B8 only if the nature of the process allows it, because otherwise it can lead to loss of performance due to limited voltage. Bit B8 can be used if there is no need to run against current or torque limit or handle high loads at low frequencies in normal operation. An example of a situation when the bit must not be used is operation against a locked rotor.

Bit B14

Bit B14 defines the reaction of the ramp output during the limit control functions. By default, the limit controls have no effect on the ramp output. It causes the motor to accelerate with maximum torque (against the current limit) to the speed reference when the limit control deactivates.

By activating bit B14, the ramp output follows the actual frequency/speed with a defined gap. Thus, when the limit control deactivates, the motor accelerates to the speed reference with the defined ramp time. The default value of the gap frequency is 3.0 Hz.

11.4.7.3 (ID 1733) Speed Control Gain

Location in the menu: **P3.1.6.8**

The speed controller is always active in advanced sensorless control. Depending on the desired response and the total inertia, it is possible that the speed controller requires some tuning.

11.4.7.4 (ID 1734) Speed Control Time

Location in the menu: **P3.1.6.9**

The speed controller is always active in advanced sensorless control. Depending on the desired response and the total inertia, it is possible that the speed controller requires some tuning.

11.4.7.5 (ID 1250) Flux Reference

Location in the menu: **P3.1.6.14**

Use this parameter to adjust the flux reference. The value 100% means a nominal flux.

11.5 Start/Stop Setup

11.5.1 Start and Stop Commands in Different Control Places

Start and stop commands must be given differently in each control place.

Remote Control Place (I/O A)

Use the parameters P3.5.1.1 (Control signal 1 A), P3.5.1.2 (Control signal 2 A) and P3.5.1.3 (Control signal 3 A) to select digital inputs. These digital inputs control the start, stop, and reverse commands. Then select a logic for these inputs with P3.2.6 I/O A Logic.

Remote Control Place (I/O B)

Use the parameters P3.5.1.4 (Control signal 1 B), P3.5.1.5 (Control signal 2 B) and P3.5.1.6 (Control signal 3 B) to select digital inputs. These digital inputs control the start, stop, and reverse commands. Then select a logic for these inputs with P3.2.7 I/O B Logic.

Local Control Place (Keypad)

The start and stop commands come from the keypad buttons. The direction of the rotation is set with parameter P3.3.1.9 Keypad direction.

Remote Control Place (Fieldbus)

Start, stop, and reverse commands come from the fieldbus.

11.5.2 (ID 172) Remote Control Place

Location in the menu: **P3.2.1**

Use this parameter to select the remote control place (start/stop). Use this parameter to change back to remote control from VACON® Live, for example if the control panel is broken.

11.5.3 (ID 211) Local/Remote

Location in the menu: **P3.2.2**

Use this parameter to switch between the local and remote control places. Local control place is always keypad control. The remote control place can be I/O or Fieldbus, depending on the 'Remote Control Place' parameter value.

11.5.4 (ID 114) Keypad Stop Button

Location in the menu: **P3.2.3**

Use this parameter to enable the keypad stop button. When this function is enabled, a press of keypad stop button always stops the drive (regardless of the control place). When this function is disabled, a press of keypad stop button stops the drive in local control only.

Selection number	Selection name	Description
0	Yes	The keypad stop button is always enabled.
1	No	Limited function of the keypad stop button.

11.5.5 (ID 505) Start Function

Location in the menu: **P3.2.4**

Use this parameter to select the type of the start function.

Selection number	Selection name	Description
0	Ramping	The drive accelerates from 0 frequency to frequency reference.
1	Flying start	The drive detects the actual speed of the motor and accelerates from that speed to frequency reference.

11.5.6 (ID 506) Stop Function

Location in the menu: **P3.2.5**

Use this parameter to select the type of the stop function.

Selection number	Selection name	Description
0	Coasting	The motor stops on its inertia. When the stop command is given, the control by the drive stops and the current from the drive goes to 0.
1	Ramp	After the stop command, the speed of the motor is decreased to zero speed according to the deceleration parameters.

N O T I C E

Ramp stop cannot be guaranteed in all situations. If ramp stop is selected and the net voltage changes over 20%, the voltage estimation fails. In such case, ramp stop is not possible.

11.5.7 (ID 300) I/O A Start/Stop Logic

Location in the menu: **P3.2.6**

Use this parameter to control the start and stop of the drive with the digital signals. The selections can include the word 'edge' to help preventing an accidental start.

An accidental start can occur, for example, in these conditions:

- When the power is connected.
- When the power is connected again after a power cut.
- After resetting a fault.
- After Run Enable stops the drive.
- When changing the control place to I/O control.

Before starting the motor, the Start/Stop contact must be opened.

In all the examples of the next pages, the stop mode is coasting. CS = Control signal.

e30bu037

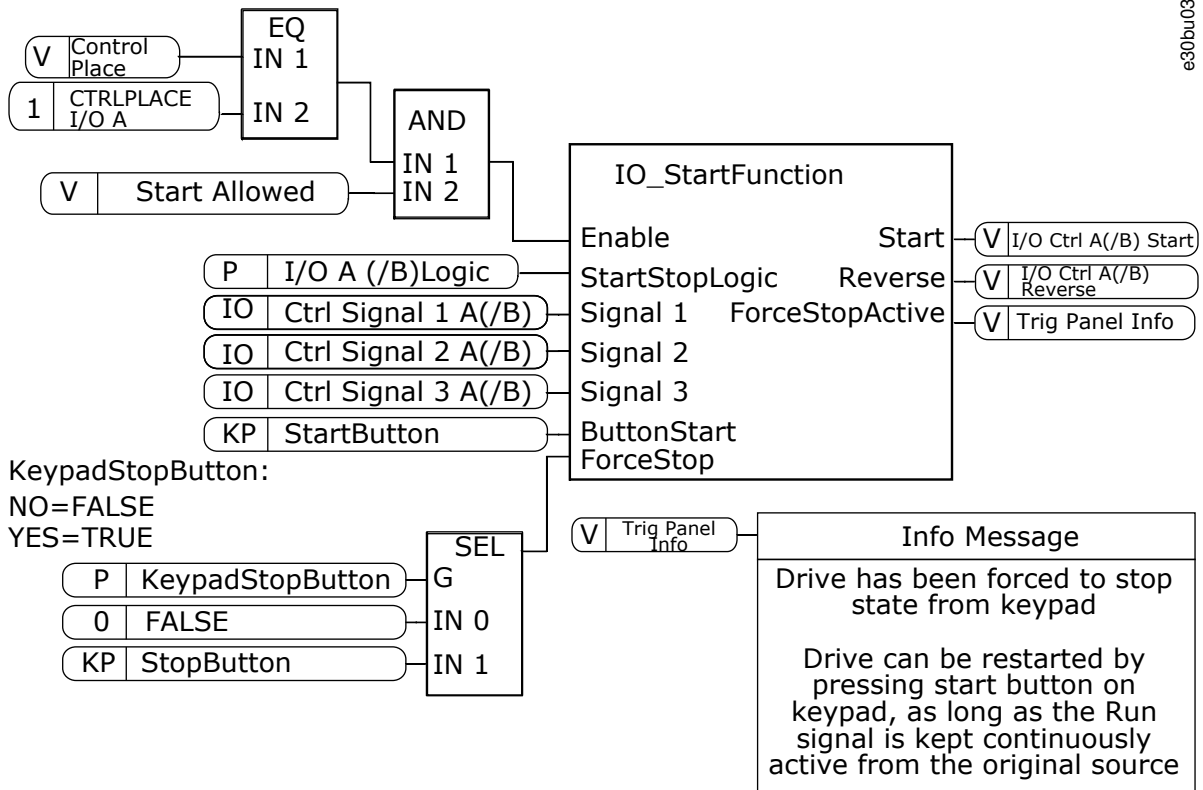

Illustration 25: The Block Diagram of the I/O A Start/Stop Logic

Selection = 0

Selection number	Selection name	Description
0	CS1 = Forward CS2 = Backward	The functions activate when the contacts are closed.

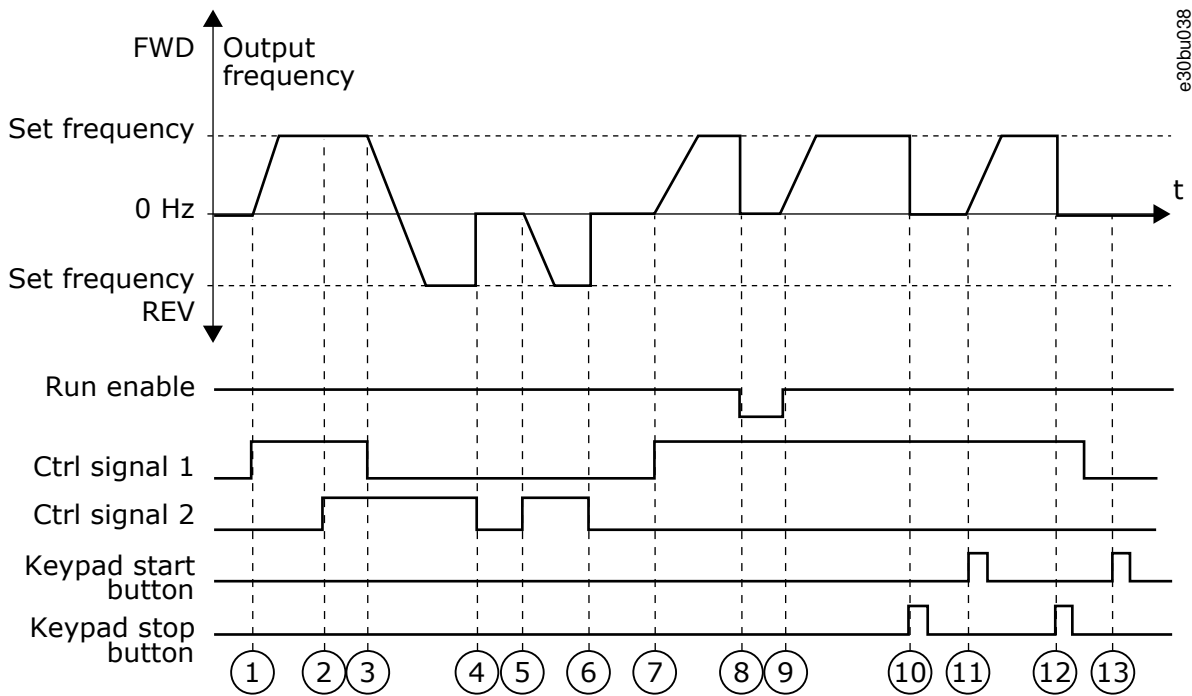

Illustration 26: I/O A Start/Stop Logic = 0

<p>1 Control signal (CS) 1 activates and causes the output frequency to increase. The motor operates forward.</p> <p>2 CS2 activates, but it does not affect the output frequency, because the direction that is set first has the highest priority.</p> <p>3 CS1 becomes inactive and causes the direction to start to change (FWD to REV), because CS2 is still active.</p> <p>4 CS2 becomes inactive and the frequency that is fed to the motor goes to 0.</p> <p>5 CS2 activates again and causes the motor to accelerate (REV) to the set frequency.</p> <p>6 CS2 becomes inactive and the frequency fed to the motor drops to 0.</p> <p>7 CS1 activates and the motor accelerates (FWD) to the set frequency.</p>	<p>8 The Run enable signal is set to OPEN, which causes the frequency to go to 0. Configure the Run enable signal with parameter P3.5.1.15.</p> <p>9 The Run enable signal is set to CLOSED, which causes the frequency to increase to the set frequency, because CS1 is still active.</p> <p>10 The STOP button on the keypad is pushed, and the frequency that is fed to the motor goes to 0. (This signal only works if the value of P3.2.3 Keypad Stop Button is Yes.)</p> <p>11 The drive starts because the START button on the keypad was pushed.</p> <p>12 The STOP button on the keypad is pushed again to stop the drive.</p> <p>13 The attempt to start the drive with the START button is not successful, because CS1 is inactive.</p>
---	--

Selection = 1

Selection number	Selection name	Description
1	CS1 = Forward (edge) CS2 = Inverted stop CS3 = Backward (edge)	For a 3-wire control (pulse control)

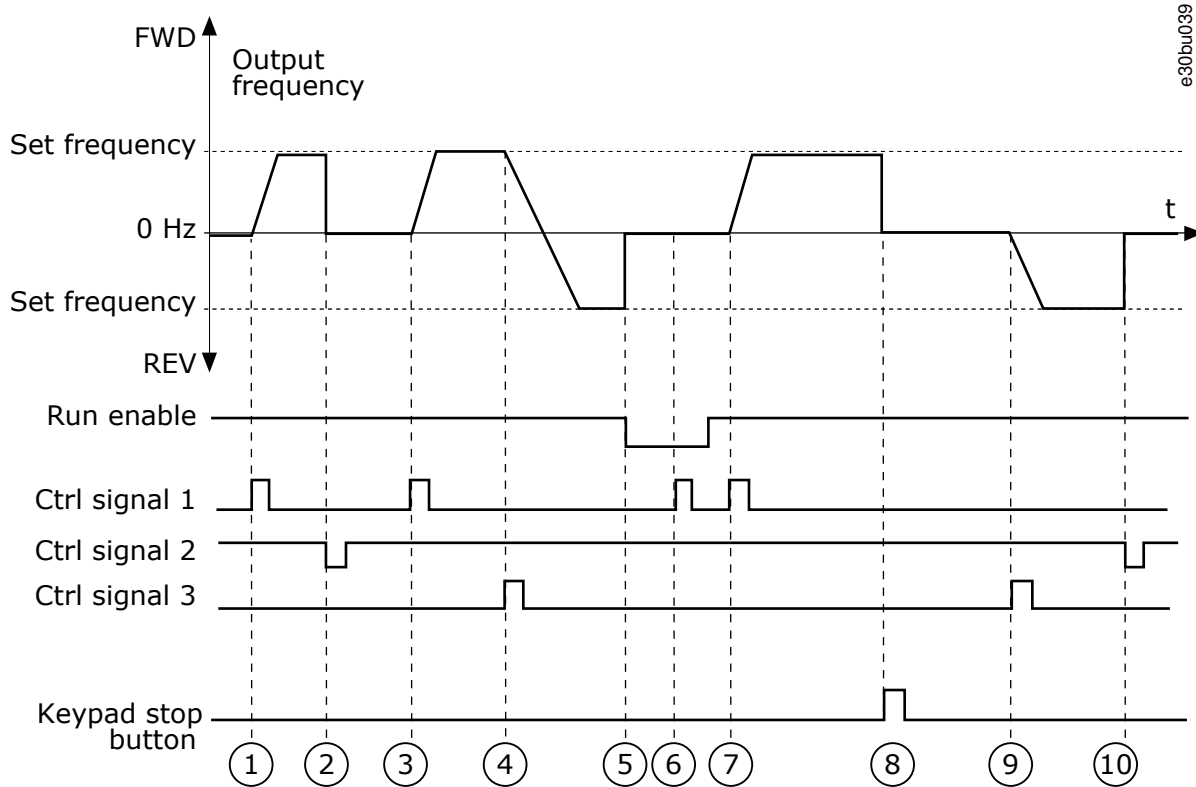
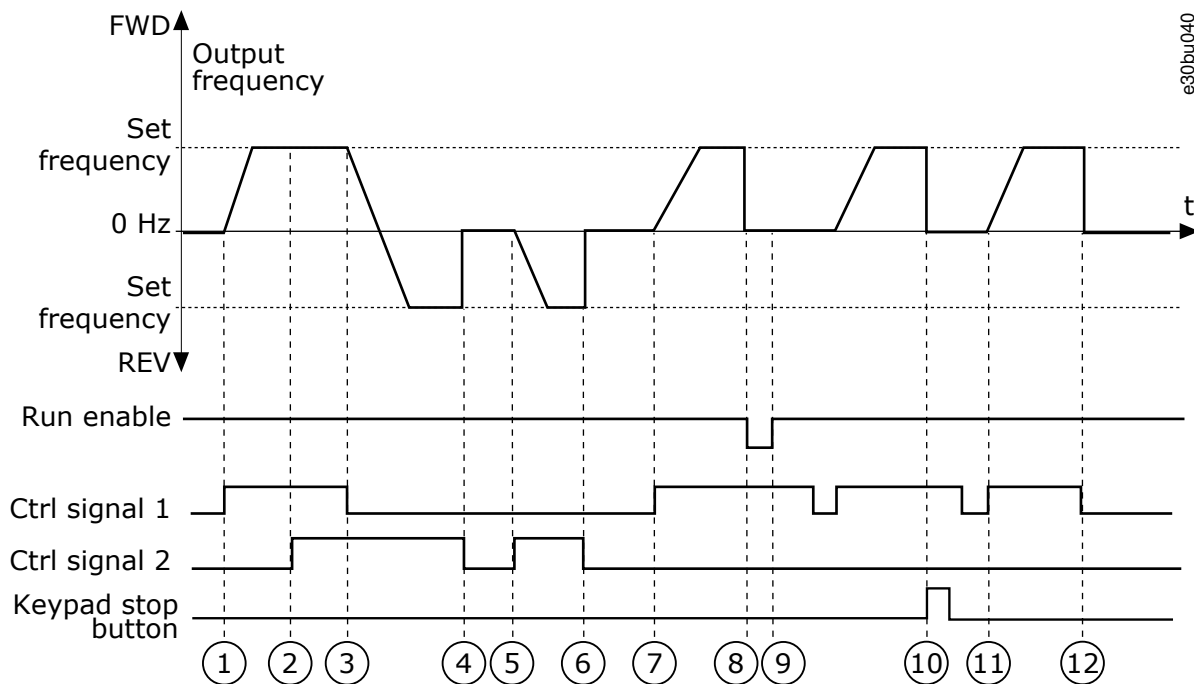

Illustration 27: I/O A Start/Stop Logic = 1

<p>1 Control signal (CS) 1 activates and causes the output frequency to increase. The motor operates forward.</p> <p>2 CS2 becomes inactive and causes the frequency to go to 0.</p> <p>3 CS1 activates and causes the output frequency to increase again. The motor operates forward.</p> <p>4 CS3 activates and causes the direction to start to change (FWD to REV).</p> <p>5 The Run enable signal is set to OPEN, which causes the frequency to go to 0. Configure the Run enable signal with parameter 3.5.1.15.</p>	<p>6 The start attempt with CS1 is not successful, because the Run enable signal is still OPEN.</p> <p>7 CS1 activates and the motor accelerates (FWD) to the set frequency, because the Run enable signal was set to CLOSED.</p> <p>8 The STOP button on the keypad is pushed, and the frequency that is fed to the motor goes to 0. (This signal only works if the value of P3.2.3 Keypad Stop Button is Yes.)</p> <p>9 CS3 activates and causes the motor to start and to operate in the reverse direction.</p> <p>10 CS2 becomes inactive and causes the frequency to go to 0.</p>
--	--

Selection = 2

Selection number	Selection name	Description
2	CS1 = Forward (edge) CS2 = Backward (edge)	Use this function to prevent an accidental start. Before starting the motor again, the start/stop contact must be opened.



e30bu040

Illustration 28: I/O A Start/Stop Logic = 2

1	Control signal (CS) 1 activates and causes the output frequency to increase. The motor operates forward.	7	CS1 activates and the motor accelerates (FWD) to the set frequency.
2	CS2 activates, but it does not affect the output frequency, because the direction that is set first has the highest priority.	8	The Run enable signal is set to OPEN, which causes the frequency to go to 0. Configure the Run enable signal with parameter P3.5.1.15.
3	CS1 becomes inactive and causes the direction to start to change (FWD to REV), because CS2 is still active.	9	The Run enable signal is set to CLOSED, which does not affect, because a rising edge is necessary for the start, even if CS1 is active.
4	CS2 becomes inactive and the frequency that is fed to the motor goes to 0.	10	The STOP button on the keypad is pushed and the frequency that is fed to the motor goes to 0. (This signal only works if the value of P3.2.3 Keypad Stop Button is Yes.)
5	CS2 activates again and causes the motor to accelerate (REV) to the set frequency.	11	CS1 is opened and closed again, which causes the motor to start.
6	CS2 becomes inactive and the frequency that is fed to the motor goes to 0.	12	CS1 becomes inactive and the frequency that is fed to the motor goes to 0.

Selection = 3

Selection number	Selection name	Description
3	CS1 = Start CS2 = Reverse	

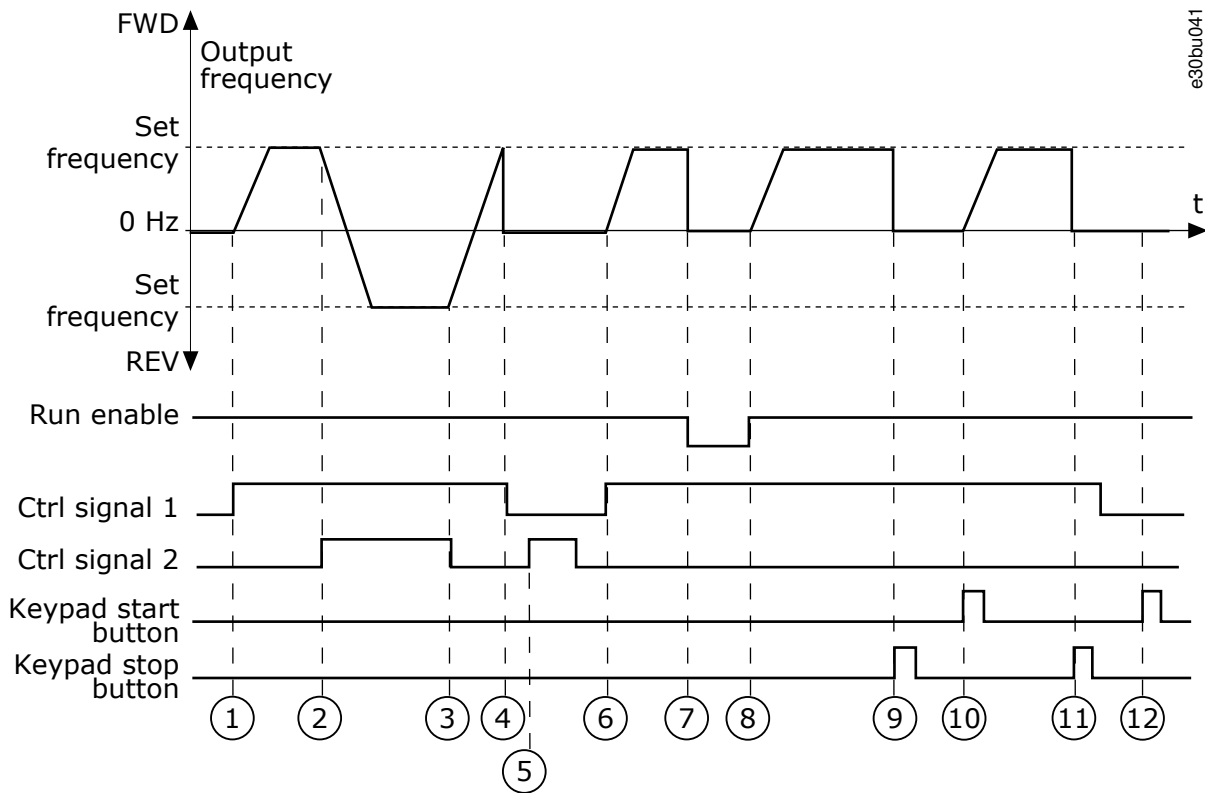

Illustration 29: I/O A Start/Stop Logic = 3

<p>1 Control signal (CS) 1 activates and causes the output frequency to increase. The motor operates forward.</p> <p>2 CS2 activates and causes the direction to start to change (FWD to REV).</p> <p>3 CS2 becomes inactive, which causes the direction to start to change (REV to FWD), because CS1 is still active.</p> <p>4 CS1 becomes inactive and the frequency goes to 0.</p> <p>5 CS2 activates, but the motor does not start because CS1 is inactive.</p> <p>6 CS1 activates and causes the output frequency to increase again. The motor operates forward because CS2 is inactive.</p>	<p>7 The Run enable signal is set to OPEN, which causes the frequency to go to 0. Configure the Run enable signal with parameter P3.5.1.15.</p> <p>8 The Run enable signal is set to CLOSED, which causes the frequency to increase to the set frequency, because CS1 is still active.</p> <p>9 The STOP button on the keypad is pushed and the frequency that is fed to the motor goes to 0. (This signal only works if the value of P3.2.3 Keypad Stop Button is Yes.)</p> <p>10 The drive starts because the START button on the keypad was pushed.</p> <p>11 The drive is stopped again with the STOP button on the keypad.</p> <p>12 The attempt to start the drive with the START button is not successful, because CS1 is inactive.</p>
---	--

Selection = 4

Selection number	Selection name	Description
4	CS1 = Start (edge) CS2 = Reverse	Use this function to prevent an accidental start. Before starting the motor again, the start/stop contact must be opened.

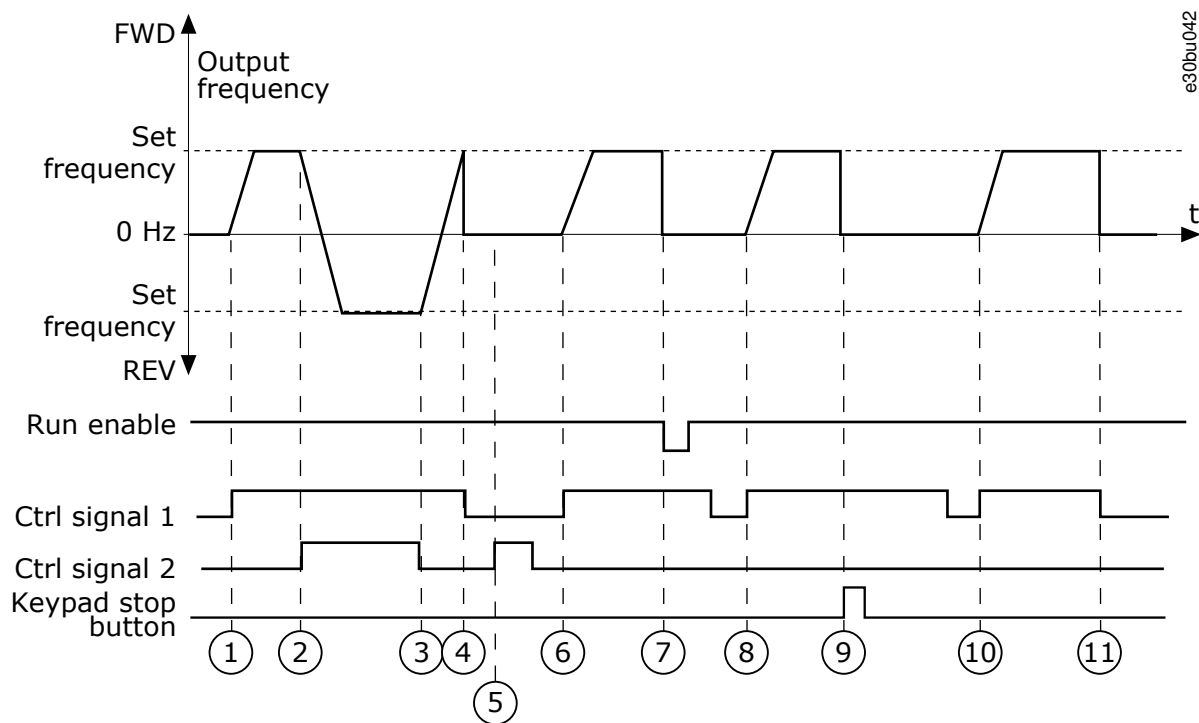

Illustration 30: I/O A Start/Stop Logic = 4

1	Control signal (CS) 1 activates and causes the output frequency to increase. The motor operates forward because CS2 is inactive.	7	The Run enable signal is set to OPEN, which causes the frequency to go to 0. Configure the Run enable signal with parameter P3.5.1.15.
2	CS2 activates, which causes the direction to start to change (FWD to REV).	8	Before the drive can start, CS1 must be opened and closed again.
3	CS2 becomes inactive, which causes the direction to start to change (REV to FWD), because CS1 is still active.	9	The STOP button on the keypad is pushed and the frequency that is fed to the motor goes to 0. (This signal only works if the value of P3.2.3 Keypad Stop Button is Yes.)
4	CS1 becomes inactive and the frequency goes to 0.	10	Before the drive can start, CS1 must be opened and closed CS1 again.
5	CS2 activates, but the motor does not start because CS1 is inactive.	11	CS1 becomes inactive and the frequency goes to 0.
6	CS1 activates and causes the output frequency to increase again. The motor operates forward, because CS2 is inactive.		

11.5.8 (ID 363) I/O B Start/Stop Logic

Location in the menu: **P3.2.7**

Use this parameter to control the start and stop of the drive with the digital signals. The selections can include the word 'edge' to help to prevent an accidental start. See P3.2.6 for more information.

11.5.9 (ID 889) Fieldbus Start Logic

Location in the menu: **P3.2.8**

Use this parameter to set the fieldbus start logic. The selections can include the word 'edge' to help to prevent an accidental start.

Selection number	Selection name	Description
0	A rising edge is necessary	
1	State	

11.5.10 (ID 524) Start Delay

Location in the menu: **P3.2.9**

Use this parameter to set the delay between the start command and the actual start of the drive.

11.5.11 (ID 181) Remote to Local Function

Location in the menu: **P3.2.10**

Use this parameter to set the selection of copy settings when going from Remote to Local (keypad) control.

Selection number	Selection name	Description
0	Keep Run	
1	Keep Run & Reference	
2	Stop	

11.6 References

11.6.1 Frequency Reference

It is possible to program the source of the frequency reference in all the control places, except the PC tool. When using PC, it always takes the frequency reference from the PC tool.

Remote Control Place (I/O A)

To set the source of the frequency reference for I/O A, use the parameter P3.3.1.5.

Remote Control Place (I/O B)

To set the source of the frequency reference for I/O B, use the parameter P3.3.1.6.

Local Control Place (Keypad)

If the default value keypad for the parameter P3.3.1.7 is used, the reference that was set for P3.3.1.8 Keypad Reference applies.

Remote Control Place (Fieldbus)

If the default value fieldbus for the parameter P3.3.1.10 is used, the frequency reference comes from fieldbus.

11.6.1.1 (ID 101) Minimum Frequency Reference

Location in the menu: **P3.3.1.1**

Use this parameter to set the minimum frequency reference.

11.6.1.2 (ID 102) Maximum Frequency Reference

Location in the menu: **P3.3.1.2**

Use this parameter to set the maximum frequency reference.

11.6.1.3 (ID 1285) Positive Frequency Reference Limit

Location in the menu: **P3.3.1.3**

Use this parameter to set the final frequency reference limit for the positive direction.

11.6.1.4 (ID 1286) Negative Frequency Reference Limit

Location in the menu: **P3.3.1.4**

Use this parameter to set the final frequency reference limit for the negative direction. Use this parameter for example to prevent the motor from running in the reverse direction.

11.6.1.5 (ID 117) I/O Control Reference A Selection

Location in the menu: **P3.3.1.5**

Use this parameter to select the reference source when the control place is I/O A. The application set with parameter 1.2 gives the default value.

11.6.1.6 (ID 131) I/O Control Reference B Selection

Location in the menu: **P3.3.1.6**

Use this parameter to select the reference source when the control place is I/O B. See P3.3.1.5 for more information. It is possible to force the I/O B control place to be active only with a digital input (P3.5.1.7).

11.6.1.7 (ID 121) Keypad Control Reference Selection

Location in the menu: **P3.3.1.7**

Use this parameter to select the reference source when the control place is keypad.

11.6.1.8 (ID 184) Keypad Reference

Location in the menu: **P3.3.1.8**

Use this parameter to adjust the frequency reference on the keypad.

11.6.1.9 (ID 123) Keypad Direction

Location in the menu: **P3.3.1.9**

Use this parameter to set the rotation direction of the motor when the control place is keypad.

11.6.1.10 (ID 122) Fieldbus Control Reference Selection

Location in the menu: **P3.3.1.10**

Use this parameter to select the reference source when the control place is Fieldbus.

The selection of the application with parameter *P1.2Application* gives the default value. See the default values in [11.27 Default Values of Parameters in the Different Applications](#).

11.6.2 Torque Reference

When the parameter P3.1.2.1 (Control Mode) is set to Torque control open loop, the motor torque is controlled. The motor speed changes to agree with the actual load on the motor shaft. P3.3.2.7 (Torque Control Frequency Limit) controls the motor speed limit.

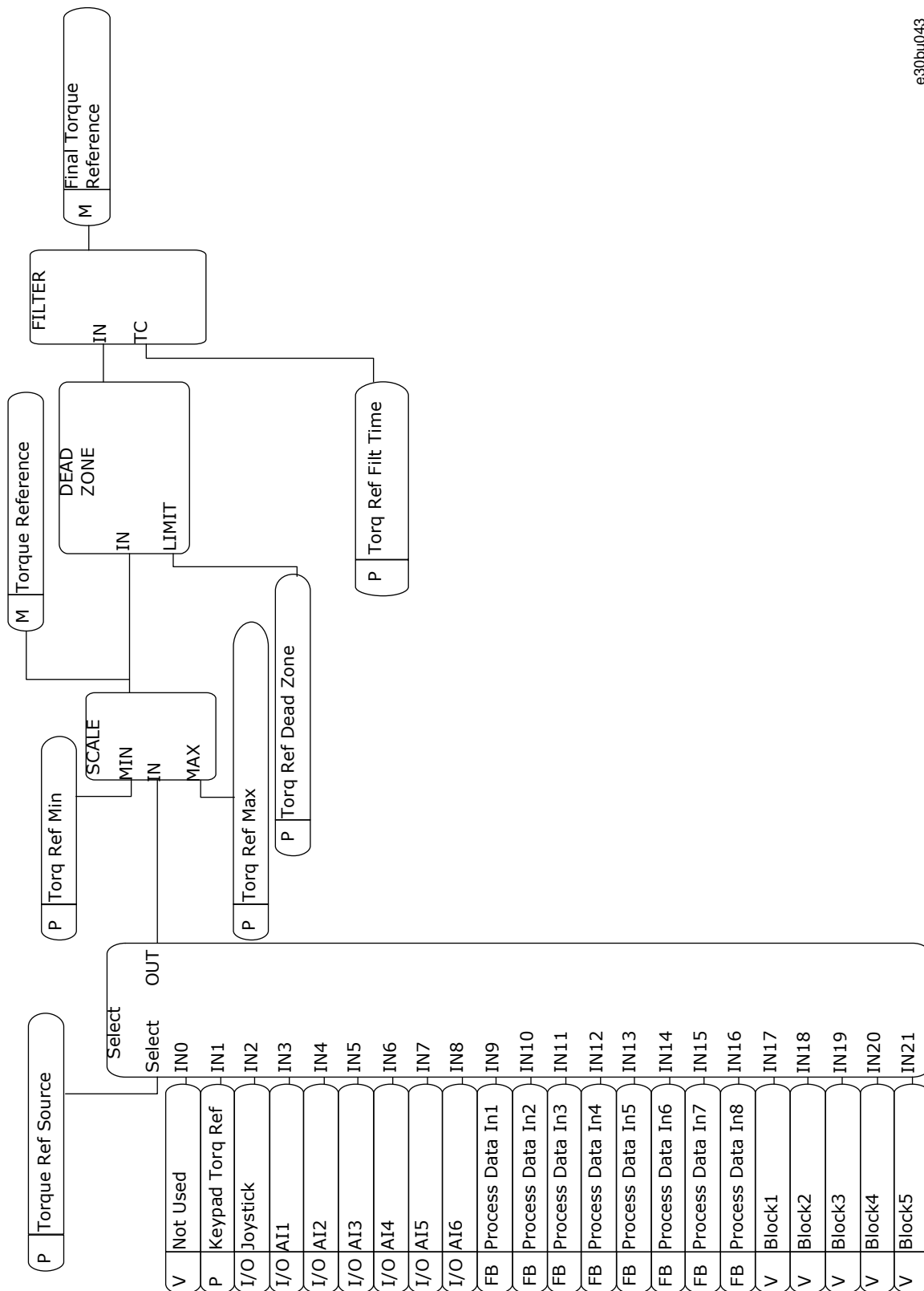

e30bu043

Illustration 31: The Torque Reference Chain Diagram

11.6.2.1 (ID 641) Torque Reference Selection

Location in the menu: P3.3.2.1

Use this parameter to select the torque reference.

The torque reference is scaled between the values of P3.3.2.2. and P3.3.2.3. When using a fieldbus protocol where the torque reference can be given in Nm units, set ProcessDataIn1 as the value to this parameter.

11.6.2.2 (ID 643) Torque Minimum Reference

Location in the menu: **P3.3.2.2**

Use this parameter to set the minimum torque reference. This parameter defines the minimum torque reference of the positive and negative values.

NOTICE

This value is not applied when torque reference source is Joystick.

11.6.2.3 (ID 642) Torque Maximum Reference

Location in the menu: **P3.3.2.3**

Use this parameter to set the maximum torque reference of the positive and negative values.

These parameters define the scaling of selected torque reference signal. For instance, the analog input signal is scaled between the Torque Reference Minimum and the Torque Reference Maximum.

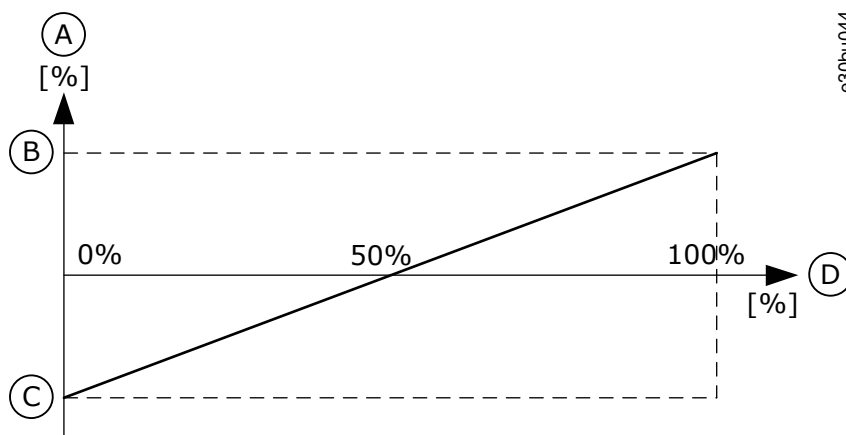

Illustration 32: Scaling of the Torque Reference Signal

A	Torque reference	C	Torque reference minimum
B	Torque reference maximum	D	Analog input signal

11.6.2.4 (ID 1244) Torque Reference Filter Time

Location in the menu: **P3.3.2.4**

Use this parameter to set the filtering time for the final torque reference.

11.6.2.5 (ID 1246) Torque Reference Dead Zone

Location in the menu: **P3.3.2.5**

Use this parameter to set the torque reference dead zone.

To ignore the small values around 0 of the torque reference, set this value to be bigger than 0. When the reference signal is between 0 and $0 \pm$ the value of this parameter, the torque reference is set to 0.

11.6.2.6 (ID 1439) Keypad Torque Reference

Location in the menu: **P3.3.2.6**

Use this parameter to set the keypad torque reference. This parameter is used when P3.3.2.1. is set to 1. The value of this parameter is limited between P3.3.2.3. and P3.3.2.2.

11.6.2.7 (ID 1278) Torque Control Frequency Limit

Location in the menu: **P3.3.2.7**

Use this parameter to select the output frequency limit mode for the torque control. In the torque control mode, the drive output frequency is always limited between MinFreqReference and MaxFreqReference (P3.3.1.1 and P3.3.1.2).

Also the selection of 2 other modes is possible with this parameter.

Selection 0 = Pos/Neg Freq Limits, that is, the positive/negative frequency limits.

The frequency is limited between Positive Frequency Reference Limit (P3.3.1.3) and Negative Frequency Reference Limit (P3.3.1.4) (if these parameters are set lower than the value of P3.3.1.2 Maximum Frequency).

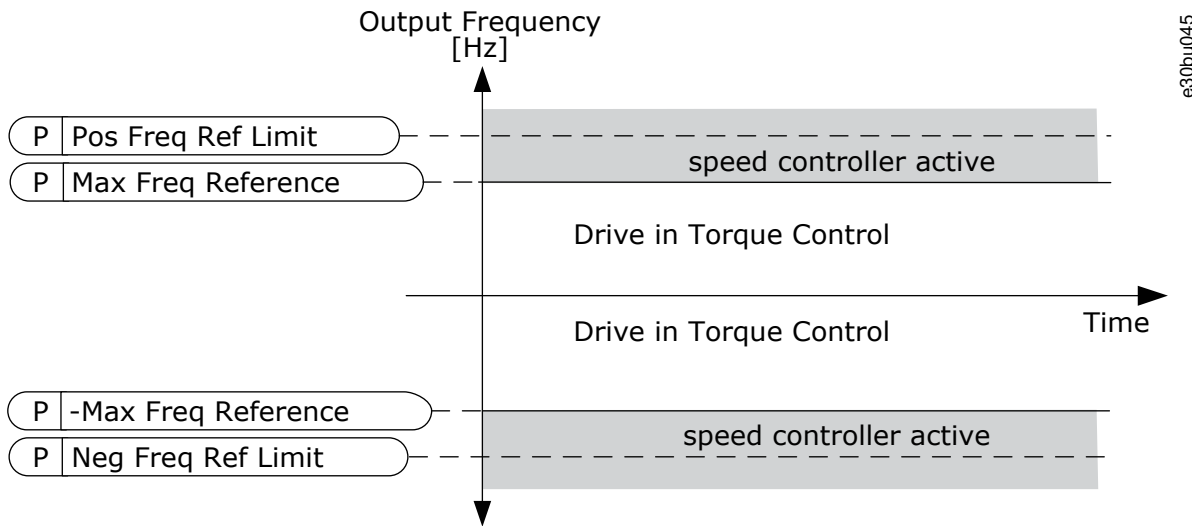

Illustration 33: Torque Control Frequency Limit, Selection 0

Selection 1 = Freq Reference, that is, the frequency reference for both directions.

The frequency is limited by the actual frequency reference (after the ramp generator) for both directions. That is, the output frequency increases within the set ramp time until the actual torque is equal to the referenced torque.

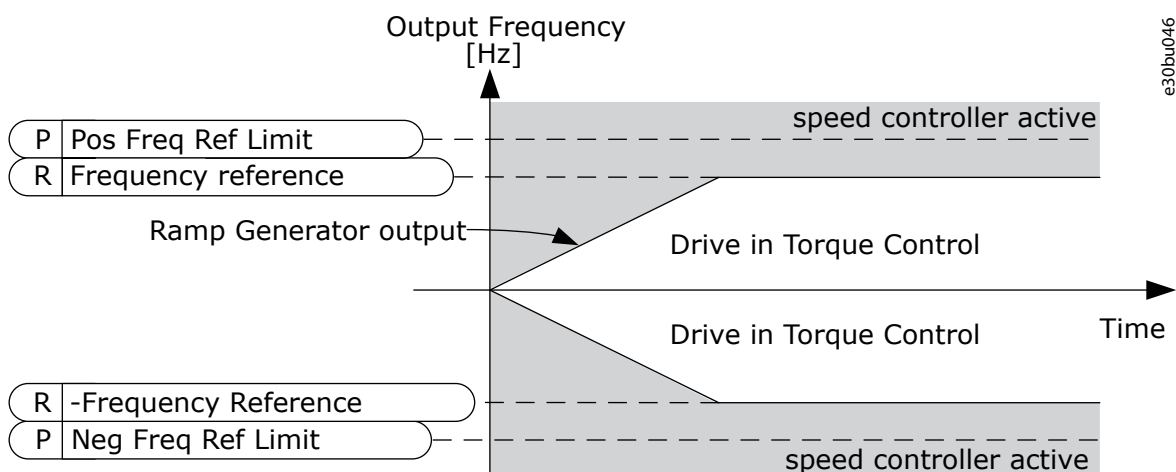

Illustration 34: Torque Control Frequency Limit, Selection 1

11.6.3 Torque Control in Open Loop Control

11.6.3.1 (ID 636) Open Loop Torque Control Minimum Frequency

Location in the menu: P3.3.2.8.1

Use this parameter to set the output frequency limit below which the drive operates in the frequency control mode.

11.6.3.2 (ID 639) Open Loop Torque Control P Gain

Location in the menu: P3.3.2.8.2

Use this parameter to set the P gain for the torque controller in the open loop control mode.

The P Gain value 1.0 causes a 1 Hz change in the output frequency when the torque error is 1% of the motor nominal torque.

11.6.3.3 (ID 640) Open Loop Torque Control I Gain

Location in the menu: **P3.3.2.8.3**

Use this parameter to set the I gain for the torque controller in the open loop control mode.

The I Gain value 1.0 causes the integration to reach 1.0 Hz in 1 second when the torque error is 1% of the motor nominal torque.

11.6.4 Torque Control in Advanced Sensorless Control

11.6.4.1 (ID 1731) Sensorless Torque Control P Gain

Location in the menu: **P3.3.2.9.1**

Use this parameter to set the P gain for the torque controller in the sensorless control mode. The P Gain value 1.0 causes a 1 Hz change in the output frequency when the torque error is 1% of the motor nominal torque.

This parameter is always active in sensorless torque control.

11.6.4.2 (ID 1732) Sensorless Torque Control I Gain

Location in the menu: **P3.3.2.9.2**

Use this parameter to set the I gain for the torque controller in the sensorless control mode. The I Gain value 1.0 causes the integration to reach 1.0 Hz in 1 second when the torque error is 1% of the motor nominal torque.

This parameter is always active in sensorless torque control.

11.6.5 Preset Frequencies

Use the Preset frequencies function in processes where more than 1 fixed frequency reference is necessary. There are 8 preset frequency references available. The selection of a preset frequency reference can be made with the digital input signals P3.3.3.10, P3.3.3.11, and P3.3.3.12.

11.6.5.1 (ID 182) Preset Frequency Mode

Location in the menu: **P3.3.3.1**

Use this parameter to set the logic of the digital input preset frequencies.

With this parameter, it is possible to set the logic which one of the preset frequencies is selected into use. There is a selection of 2 different logics. The number of preset speed digital inputs that are active defines the preset frequency.

Selection number	Selection name	Description
0	Binary coded	The mix of the inputs is binary coded. The different sets of active digital inputs determine the preset frequency.
1	Number (of inputs used)	The number of active inputs tells which preset frequency is used: 1, 2 or 3.

Value 0 selected

To set Preset Frequency 0 as reference, set the value 0 *Preset Frequency 0* for P3.3.1.5 (see [11.6.1.5 \(ID 117\) I/O Control Reference A Selection](#)).

To select a preset frequency 1–7, give digital inputs to P3.3.3.10 ([11.6.5.10 \(ID 419\) Preset Frequency Selection 0](#)), P3.3.3.11 ([11.6.5.11 \(ID 420\) Preset Frequency Selection 1](#)), and/or P3.3.3.12 ([11.6.5.12 \(ID 421\) Preset Frequency Selection 2](#)). The different sets of active digital inputs determine the preset frequency. For more data, see the following table. The values of the preset frequencies stay automatically between the minimum and maximum frequencies (P3.3.1.1 and P3.3.1.2).

Necessary step	Activated frequency
Select the value 0 for parameter P3.3.1.5.	Preset frequency 0

Table 130: The Selection of Preset Frequencies when Preset Frequency Mode is *Binary Coded*

Digital input signal Pre-set Freq Sel2 (P3.3.3.12)	Digital input signal Pre-set Freq Sel1 (P3.3.3.11)	Digital input signal Pre-set Freq Sel0 (P3.3.3.10)	Activated frequency reference
			Preset frequency 0

Digital input signal Pre-set Freq Sel2 (P3.3.3.12)	Digital input signal Pre-set Freq Sel1 (P3.3.3.11)	Digital input signal Pre-set Freq Sel0 (P3.3.3.10)	Activated frequency reference
			Only if Preset Freq 0 is set as frequency reference source with P3.3.3.1.5, P3.3.1.6, P3.3.1.7 or P3.3.1.10.
		Activated	Preset frequency 1
	Activated		Preset frequency 2
	Activated	Activated	Preset frequency 3
Activated			Preset frequency 4
Activated		Activated	Preset frequency 5
Activated	Activated		Preset frequency 6
Activated	Activated	Activated	Preset frequency 7

Value 1 selected

It is possible to use the Preset Frequencies 1–3 with different sets of active digital inputs. The number of active inputs tells which one is used.

Table 131: The Selection of Preset Frequencies when Preset Frequency Mode is Number of Inputs

Digital input signal Pre-set Freq Sel2 (P3.3.3.12)	Digital input signal Pre-set Freq Sel1 (P3.3.3.11)	Digital input signal Pre-set Freq Sel0 (P3.3.3.10)	Activated frequency reference
			Preset frequency 0 Only if Preset Freq 0 is set as frequency reference source with P3.3.3.1.5, P3.3.1.6, P3.3.1.7 or P3.3.1.10.
		Activated	Preset frequency 1
	Activated		Preset frequency 1
Activated			Preset frequency 1
	Activated	Activated	Preset frequency 2
Activated		Activated	Preset frequency 2
Activated	Activated		Preset frequency 2
Activated	Activated	Activated	Preset frequency 3

11.6.5.2 (ID 180) Preset Frequency 0

Location in the menu: **P3.3.3.2**

Use this parameter to set the preset frequency reference when the preset frequencies function is used. Select the preset frequencies with the digital input signals.

See more information in [11.6.5.1 \(ID 182\) Preset Frequency Mode](#).

11.6.5.3 (ID 105) Preset Frequency 1

Location in the menu: **P3.3.3.3**

Use this parameter to set the preset frequency reference when the preset frequencies function is used. Select the preset frequencies with the digital input signals.

See more information in [11.6.5.1 \(ID 182\) Preset Frequency Mode](#).

11.6.5.4 (ID 106) Preset Frequency 2

Location in the menu: **P3.3.3.4**

Use this parameter to set the preset frequency reference when the preset frequencies function is used. Select the preset frequencies with the digital input signals.

See more information in [11.6.5.1 \(ID 182\) Preset Frequency Mode](#).

11.6.5.5 (ID 126) Preset Frequency 3

Location in the menu: **P3.3.3.5**

Use this parameter to set the preset frequency reference when the preset frequencies function is used. Select the preset frequencies with the digital input signals.

See more information in [11.6.5.1 \(ID 182\) Preset Frequency Mode](#).

11.6.5.6 (ID 127) Preset Frequency 4

Location in the menu: **P3.3.3.6**

Use this parameter to set the preset frequency reference when the preset frequencies function is used. Select the preset frequencies with the digital input signals.

See more information in [11.6.5.1 \(ID 182\) Preset Frequency Mode](#).

11.6.5.7 (ID 128) Preset Frequency 5

Location in the menu: **P3.3.3.7**

Use this parameter to set the preset frequency reference when the preset frequencies function is used. Select the preset frequencies with the digital input signals.

See more information in [11.6.5.1 \(ID 182\) Preset Frequency Mode](#).

11.6.5.8 (ID 129) Preset Frequency 6

Location in the menu: **P3.3.3.8**

Use this parameter to set the preset frequency reference when the preset frequencies function is used. Select the preset frequencies with the digital input signals.

See more information in [11.6.5.1 \(ID 182\) Preset Frequency Mode](#).

11.6.5.9 (ID 130) Preset Frequency 7

Location in the menu: **P3.3.3.9**

Use this parameter to set the preset frequency reference when the preset frequencies function is used. Select the preset frequencies with the digital input signals.

See more information in [11.6.5.1 \(ID 182\) Preset Frequency Mode](#).

11.6.5.10 (ID 419) Preset Frequency Selection 0

Location in the menu: **P3.3.3.10**

Use this parameter to select the digital input signal that is used as a selector for the preset frequencies. This parameter is a binary selector for Preset speeds (0–7). See parameters P3.3.3.2 to P3.3.3.9.

11.6.5.11 (ID 420) Preset Frequency Selection 1

Location in the menu: **P3.3.3.11**

Use this parameter to select the digital input signal that is used as a selector for the preset frequencies. This parameter is a binary selector for Preset speeds (0–7). See parameters P3.3.3.2 to P3.3.3.9.

11.6.5.12 (ID 421) Preset Frequency Selection 2

Location in the menu: **P3.3.3.12**

Use this parameter to select the digital input signal that is used as a selector for the preset frequencies. This parameter is a binary selector for Preset speeds (0–7). See parameters P3.3.3.2 to P3.3.3.9.

To apply Preset frequencies 1–7, connect a digital input to these functions with the instructions in [11.8.1.2 Programming of Digital Inputs](#). See more data in [11.6.5.1 \(ID 182\) Preset Frequency Mode](#), and also in [Table 43](#), and [Table 52](#).

11.6.6 Motor Potentiometer Parameters

The frequency reference of the Motor Potentiometer is available in all the control places. It is possible to change the motor potentiometer reference only when the drive is in the run state.

NOTICE

If the output frequency is set slower than the Motor Potentiometer Ramp Time, the normal acceleration and deceleration times give limits to it.

11.6.6.1 (ID 418) Motor Potentiometer UP

Location in the menu: **P3.3.4.1**

Use this parameter to increase the output frequency with a digital input signal. With a motor potentiometer, it is possible to increase and decrease the output frequency. When a digital input is connected to parameter Motor Potentiometer UP, and the digital input signal is active, the output frequency rises. The motor potentiometer reference INCREASES until the contact is opened.

11.6.6.2 (ID 417) Motor Potentiometer DOWN

Location in the menu: **P3.3.4.2**

Use this parameter to decrease the output frequency with a digital input signal. With a motor potentiometer, it is possible to increase and decrease the output frequency. When a digital input is connected to parameter Motor Potentiometer DOWN, and the digital input signal is active, the output frequency falls. The motor potentiometer reference DECREASES until the contact is opened.

3 different parameters affect how the output frequency rises or falls when Motor Potentiometer UP or DOWN is active. These parameters are Motor Potentiometer Ramp Time (P3.3.4.3), Acceleration Time (P3.4.1.2), and Deceleration Time (P3.4.1.3).

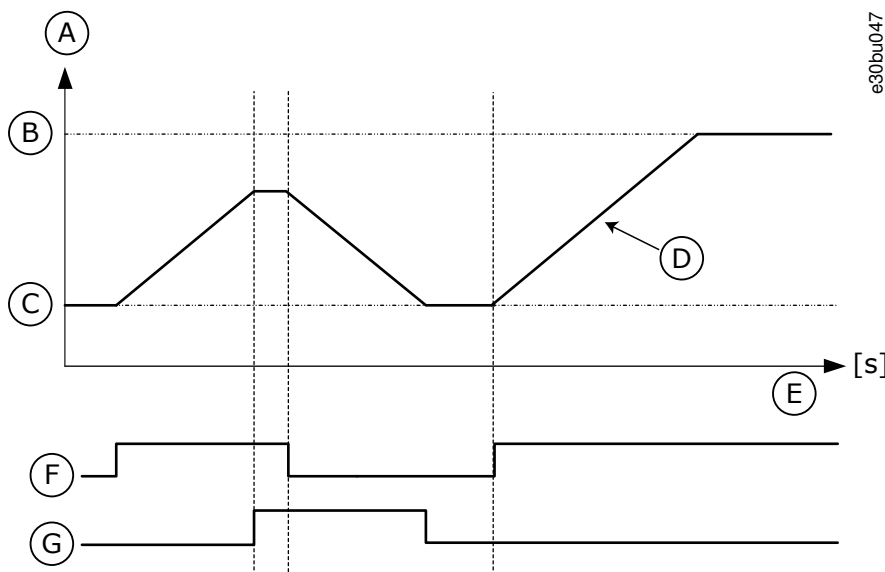

Illustration 35: The Motor Potentiometer Parameters

A	Frequency Reference	E	Time
B	Max Frequency	F	Motor potentiometer UP
C	Min Frequency	G	Motor potentiometer DOWN
D	Motor potentiometer ramp time		

11.6.6.3 (ID 331) Motor Potentiometer Ramp Time

Location in the menu: **P3.3.4.3**

Use this parameter to set the rate of change in the motor potentiometer reference when it is increased or decreased.

The parameter value is entered as Hz/second.

11.6.6.4 (ID 367) Motor Potentiometer Reset

Location in the menu: **P3.3.4.4**

Use this parameter to set the logic for the resetting of the frequency reference of the motor potentiometer.

This parameter defines when the reference of the motor potentiometer is set to 0. There are 3 selections in the reset function: no reset, reset when the drive stops, or reset when the drive is powered down.

Selection number	Selection name	Description
0	No reset	The last motor potentiometer frequency reference is kept through the stop state and kept in memory when a power-down occurs.
1	Stop state	The motor potentiometer frequency reference is set to 0 when the drive goes to the stop state, or when the drive is powered down.
2	Powered down	The motor potentiometer frequency reference is set to 0 only when a power-down occurs.

11.6.7 Joystick Parameters

Use the joystick parameters when controlling the frequency reference or the torque reference of the motor with a joystick. To control the motor with a joystick, connect the joystick signal to an analog input and set the joystick parameters.

11.6.7.1 (ID 451) Joystick Signal Selection

Location in the menu: **P3.3.5.1**

Use this parameter to set the analog input signal that controls the Joystick function. Use the Joystick function to control the frequency reference of the drive or the torque reference.

11.6.7.2 (ID 384) Joystick Dead Zone

Location in the menu: **P3.3.5.2**

Use this parameter to set the joystick dead zone. To ignore small values of the reference around the midpoint, set this value to be bigger than 0%. When the analog input signal is $50\% \pm$ the value of this parameter, the joystick reference is set to 0%.

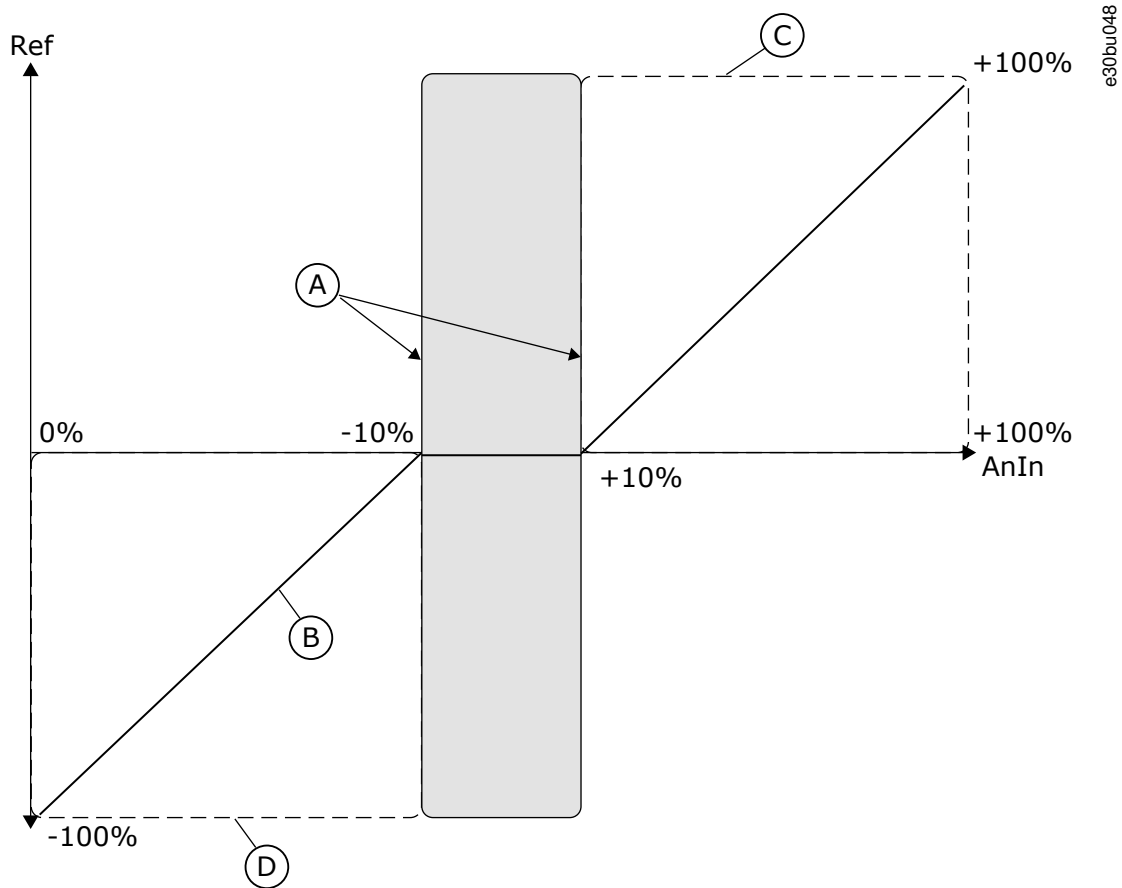

Illustration 36: The Joystick Function

A	AI joystick dead zone = 10%	C	Maximum Frequency
B	Reference	D	- Maximum Frequency

11.6.7.3 (ID 385) Joystick Sleep Zone

Location in the menu: **P3.3.5.3**

Use this parameter to set the joystick sleep zone. The AC drive stops if the joystick reference stays in the sleep zone for longer than the time period defined in parameter P3.3.5.4 Joystick Sleep Delay.

NOTICE

The Sleep function is available only if using the joystick to control the frequency reference.

11.6.7.4 (ID 386) Joystick Sleep Delay

Location in the menu: **P3.3.5.4**

Use this parameter to set the joystick sleep delay. If the joystick reference stays in the set sleep zone for longer than the sleep delay, the drive stops and the sleep mode is activated.

NOTICE

The Joystick sleep function is disabled when the value of this parameter is set to 0.

11.6.8 Jogging Parameters

Use the Jogging function to override the normal control momentarily. Use this function, for example, to control the process slowly to a special status or position during maintenance. There is no need to change the control place or other parameters.

Only when the drive is in stop state, it is possible to activate the Jogging function. It is possible use 2 bi-directional frequency references. Activate the Jogging function from the fieldbus or by digital input signals. The Jogging function has a ramp time that is used always when jogging is active.

The Jogging function starts the drive at the set reference. A new start command is not necessary. The control place does not affect it.

The Jogging function can be activated from the fieldbus in bypass mode with Control Word bits 10 and 11.

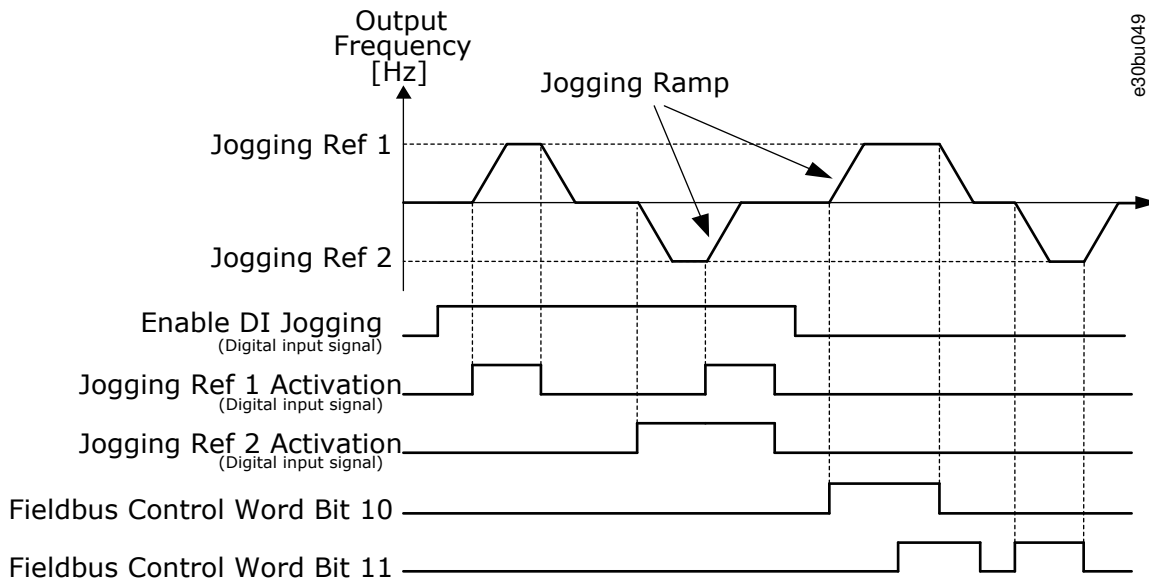

Illustration 37: The Jogging Parameters

11.6.8.1 (ID 532) Enable DI Jogging

Location in the menu: **P3.3.6.1**

Use this parameter to enable the jogging commands from digital inputs. This parameter gives the digital input signal that is used to enable jogging commands from digital inputs. This signal does not affect the jogging commands that come from Fieldbus.

11.6.8.2 (ID 530) Jogging reference 1 Activation

Location in the menu: **P3.3.6.2**

Use this parameter to set the digital input signals for the Jogging function activation. This parameter gives the digital input signal that is used to set the frequency reference for Jogging function and make the drive start. It is possible to use this digital input signal only when Enable DI Jogging is active.

NOTICE

If both Enable DI Jogging and this digital input are activated, the drive starts.

NOTICE

If the 2 activation signals are active at the same time, the drive stops.

11.6.8.3 (ID 531) Jogging reference 2 Activation

Location in the menu: **P3.3.6.3**

Use this parameter to set the digital input signals for the Jogging function activation. This parameter gives the digital input signal that is used to set the frequency reference for Jogging function and make the drive start. It is possible to use this digital input signal only when Enable DI Jogging is active.

NOTICE

If both Enable DI Jogging and this digital input are activated, the drive starts.

NOTICE

If the 2 activation signals are active at the same time, the drive stops.

11.6.8.4 (ID 1239) Jogging reference 1

Location in the menu: **P3.3.6.4**

Use this parameter to set the frequency references for the jogging function. With the parameters P3.3.6.4 and P3.3.6.5, it is possible to set the frequency references for the jogging function. The references are bi-directional. A reverse command does not affect the direction of the jogging references. The reference for the forward direction has a positive value, and the reference for the reverse direction has a negative value. The jogging function can be activated with digital input signals or from Fieldbus in bypass mode with Control Word bits 10 and 11.

11.6.8.5 (ID 1240) Jogging reference 2

Location in the menu: **P3.3.6.5**

Use this parameter to set the frequency references for the jogging function. With the parameters P3.3.6.4 and P3.3.6.5, it is possible to set the frequency references for the jogging function. The references are bi-directional. A reverse command does not affect the direction of the jogging references. The reference for the forward direction has a positive value, and the reference for the reverse direction has a negative value. The jogging function can be activated with digital input signals or from Fieldbus in bypass mode with Control Word bits 10 and 11.

11.6.8.6 (ID 1257) Jogging Ramp

Location in the menu: **P3.3.6.6**

Use this parameter to set the ramp time when jogging is active. This parameter gives the acceleration and deceleration times when the Jogging function is active.

11.7 Ramps and Brakes Setup

11.7.1 Ramp 1

11.7.1.1 (ID 500) Ramp 1 Shape

Location in the menu: **P3.4.1.1**

Use this parameter to make the start and the end of the acceleration and deceleration ramps smoother.

With the parameters Ramp 1 Shape and Ramp 2 Shape, it is possible to make smoother the start and the end of the acceleration and deceleration ramps. The value is set to 0.0% gives a linear ramp shape. The acceleration and deceleration act immediately to the changes in the reference signal.

The value set between 1.0% and 100.0% gives an S-shaped acceleration or deceleration ramp. Use this function to reduce mechanical erosion of the parts and current spikes when the reference changes. The acceleration time can be modified with parameters P3.4.1.2 (Acceleration Time 1) and P3.4.1.3 (Deceleration Time 1).

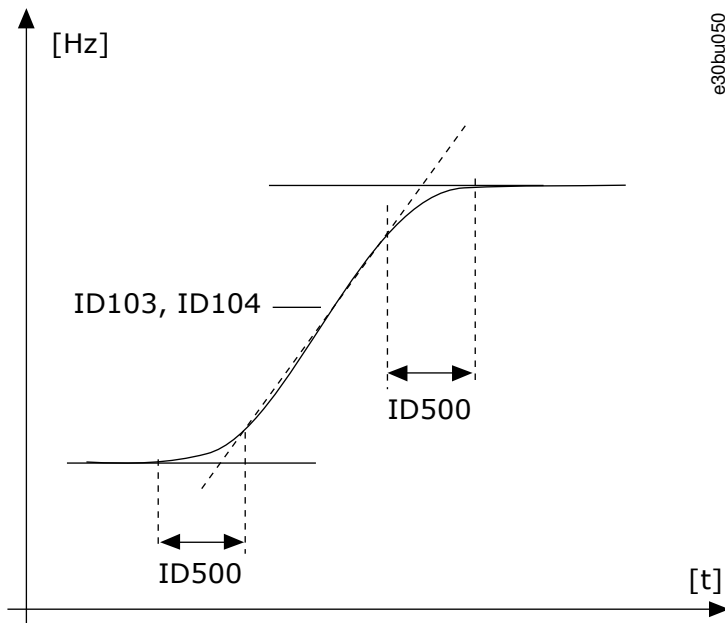

Illustration 38: The Acceleration/Deceleration Curve (S-shaped)

11.7.1.2 (ID 103) Acceleration Time 1

Location in the menu: **P3.4.1.2**

Use this parameter to set the time that is necessary for the output frequency to increase from zero frequency to maximum frequency.

11.7.1.3 (ID 104) Deceleration Time 1

Location in the menu: **P3.4.1.3**

Use this parameter to set the time that is necessary for the output frequency to decrease from maximum frequency to zero frequency.

11.7.2 Ramp 2

11.7.2.1 (ID 501) Ramp 2 Shape

Location in the menu: **P3.4.2.1**

Use this parameter to make the start and the end of the acceleration and deceleration ramps smoother.

With the parameters Ramp 1 Shape and Ramp 2 Shape, it is possible to make smoother the start and the end of the acceleration and deceleration ramps. The value set to 0.0% gives a linear ramp shape. The acceleration and deceleration act immediately to the changes in the reference signal.

The value set between 1.0% and 100.0% gives an S-shaped acceleration or deceleration ramp. Use this function to reduce mechanical erosion of the parts and current spikes when the reference changes. The acceleration time can be modified with parameters P3.4.2.2 (Acceleration Time 2) and P3.4.2.3 (Deceleration Time 2).

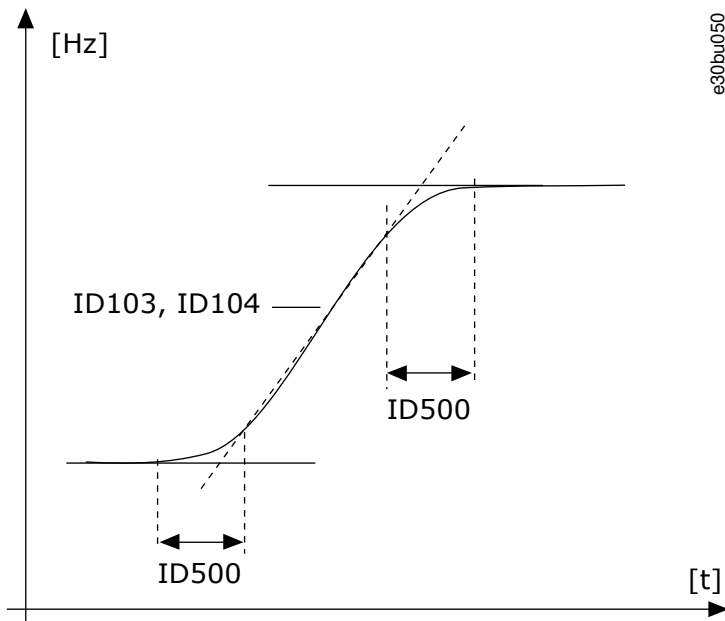

Illustration 39: The Acceleration/Deceleration Curve (S-shaped)

11.7.2.2 (ID 502) Acceleration Time 2

Location in the menu: P3.4.2.2

Use this parameter to set the time that is necessary for the output frequency to increase from zero frequency to maximum frequency.

11.7.2.3 (ID 503) Deceleration Time 2

Location in the menu: P3.4.2.3

Use this parameter to set the time that is necessary for the output frequency to decrease from maximum frequency to zero frequency.

11.7.2.4 (ID 408) Ramp 2 Selection

Location in the menu: P3.4.2.4

Use this parameter to select either ramp 1 or ramp 2.

Selection number	Selection name	Description
0	OPEN	Ramp 1 Shape, Acceleration Time 1, and Deceleration Time 1
1	CLOSED	Ramp 2 Shape, Acceleration Time 2, and Deceleration Time 2

11.7.3 Start Magnetizing

11.7.3.1 (ID 517) Start Magnetizing Current

Location in the menu: P3.4.3.1

Use this parameter to set the DC current that is fed into the motor at the start. If the value of this parameter is set to 0, the Start Magnetizing function is disabled.

11.7.3.2 (ID 516) Start Magnetizing Time

Location in the menu: P3.4.3.2

Use this parameter to set the time during which the DC current is fed to the motor before the acceleration starts.

11.7.4 DC Brake

11.7.4.1 (ID 507) DC Brake Current

Location in the menu: **P3.4.4.1**

Use this parameter to set the current that is fed into the motor during DC braking. If the value of this parameter is set to 0, the DC brake function is disabled.

11.7.4.2 (ID 508) DC Braking Time at Stop

Location in the menu: **P3.4.4.2**

Use this parameter to set the braking is ON or OFF and to give the braking time when the motor stops. If the value of this parameter is set to 0, the DC brake function is disabled.

11.7.4.3 (ID 515) Frequency to Start DC Braking at Ramp Stop

Location in the menu: **P3.4.4.3**

Use this parameter to set the output frequency at which the DC-braking starts.

See [Illustration 52](#).

11.7.5 Flux Braking

11.7.5.1 (ID 520) Flux Braking

Location in the menu: **P3.4.5.1**

Use this parameter to enable Flux Braking. It is possible to use flux braking as an alternative to DC-braking. Flux braking increases the braking capacity in conditions where extra brake resistors are not necessary.

When braking is necessary, the system decreases the frequency and increases the flux in the motor. It increases the capacity of the motor to brake. The motor speed is controlled during braking.

NOTICE

Use the braking only intermittently. Flux braking converts energy into heat and can damage the motor.

11.7.5.2 (ID 519) Flux Braking Current

Location in the menu: **P3.4.5.2**

Use this parameter to set the current level for the flux braking.

11.8 I/O Configuration

11.8.1 Programming of Digital and Analog Inputs

11.8.1.1 General Information on the Programming

The programming of inputs of the AC drive is flexible. It is possible to use freely the available inputs of the standard and optional I/O for different functions.

It is possible to expand the available capacity of I/O with option boards. It is possible to install the option boards in the slots C, D, and E. For more data on the installation of option boards, see the Installation Guide.

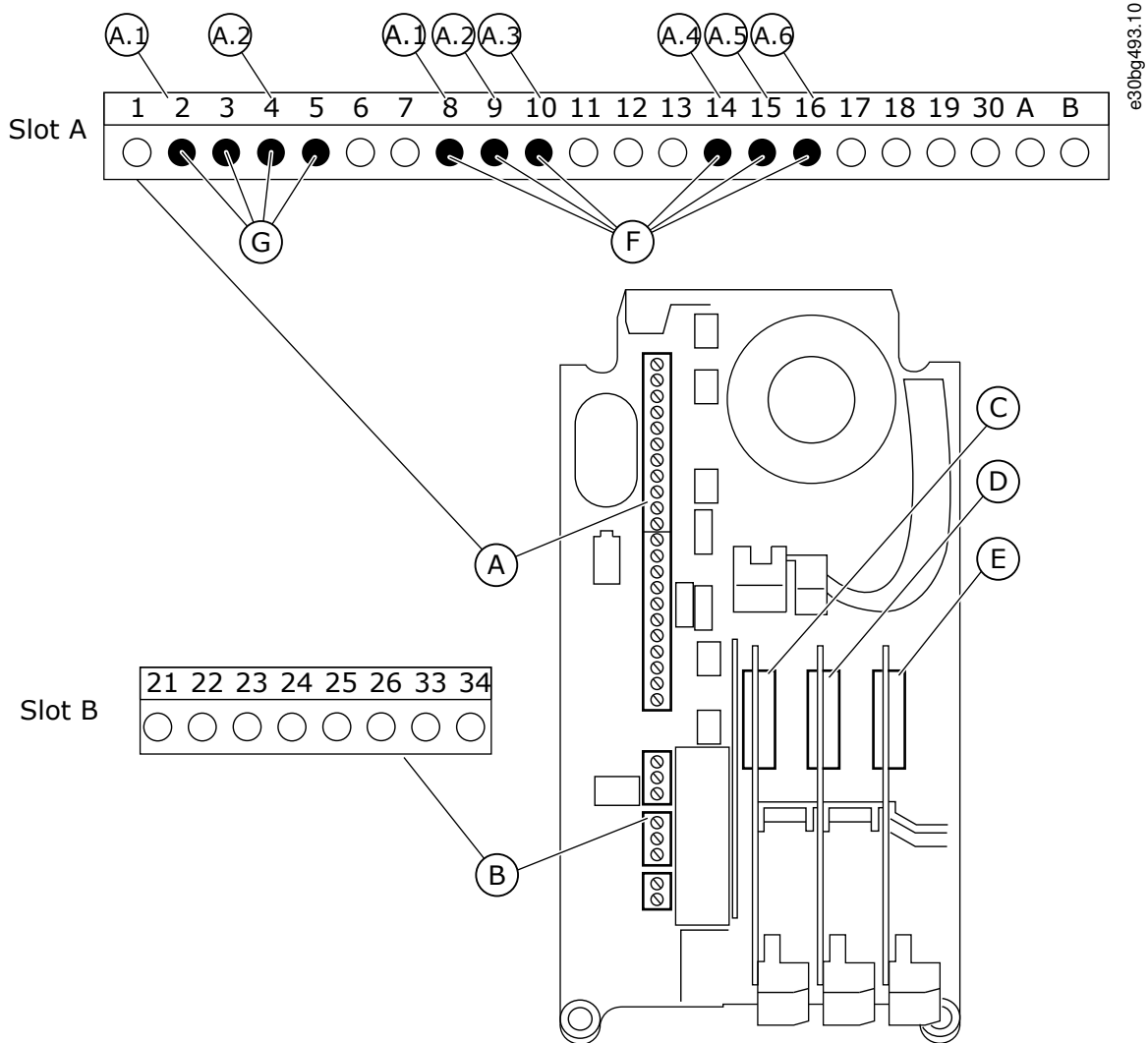

e30bg493.10

Illustration 40: The Option Board Slots and Programmable Inputs

A	Standard board slot A and its terminals	E	Option board slot E
B	Standard board slot B and its terminals	F	Programmable digital inputs (DI)
C	Option board slot C	G	Programmable analog inputs (AI)
D	Option board slot D		

11.8.1.2 Programming of Digital Inputs

Find the applicable functions for digital inputs as parameters in parameter group M3.5.1. To give a digital input to a function, set a value to the correct parameter. The list of applicable functions shows in [Table 52](#).

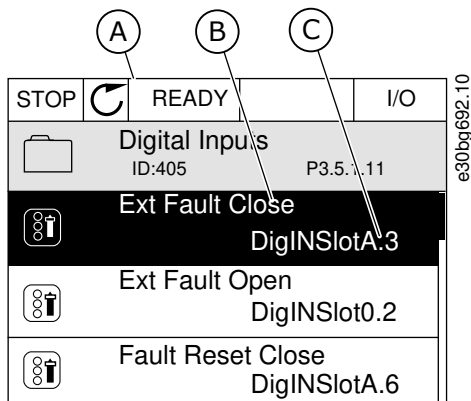

Illustration 41: The Digital Inputs Menu in the Graphical Display

A	The graphical display	C	The value of the parameter, that is, the set digital input
B	The name of the parameter, that is, the function		

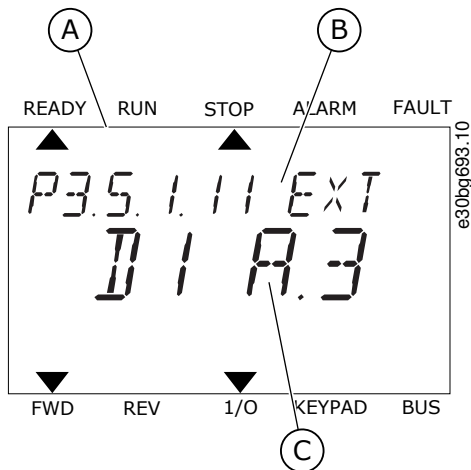

Illustration 42: The Digital Inputs Menu in the Text Display

A	The text display	C	The value of the parameter, that is, the set digital input
B	The name of the parameter, that is, the function		

Example

In the standard I/O board compilation, there are 6 digital inputs available: the slot A terminals 8, 9, 10, 14, 15 and 16.

Input type (graphical display)	Input type (text display)	Slot	Input #	Explanation
DigIN	dl	A	1	Digital input #1 (terminal 8) on a board in Slot A (standard I/O board).
DigIN	dl	A	2	Digital input #2 (terminal 9) on a board in Slot A (standard I/O board).
DigIN	dl	A	3	Digital input #3 (terminal 10) on a board in Slot A (standard I/O board).
DigIN	dl	A	4	Digital input #4 (terminal 14) on a board in Slot A (standard I/O board).
DigIN	dl	A	5	Digital input #5 (terminal 15) on a board in Slot A (standard I/O board).
DigIN	dl	A	6	Digital input #6 (terminal 16) on a board in Slot A (standard I/O board).

The function External Fault Close, the location of which is the menu M3.5.1, is parameter P3.5.1.11. It gets the default value DigIN SlotA.3 in the graphical display, and DI A.3 in the text display. After this selection, a digital signal to the digital input DI3 (terminal 10) controls External Fault Close.

Index	Parameter	Default	ID	Description
P3.5.1.11	External fault close	DigIN SlotA.3	405	OPEN = OK CLOSED = External fault

To change the input from DI3 to, for example, DI6 (terminal 16) on the standard I/O, obey these instructions.

11.8.1.3 Programming of Digital Inputs in the Graphical Display

Procedure

1. Select a parameter. To go into the Edit mode, push the arrow button Right.
2. In the Edit mode, the slot value DigIN SlotA is underlined and blinks. If there are more digital inputs available in the I/O, for example, because of option boards in slots C, D, or E, select them.

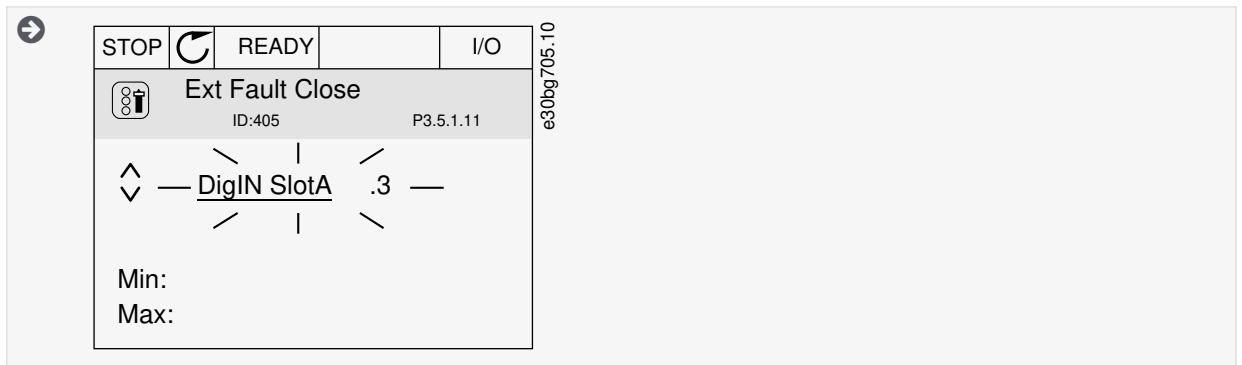

3. To activate the terminal 3, push the arrow button Right again.
4. To change the terminal to 6, push the arrow button Up 3 times. Accept the change with the [OK] button.

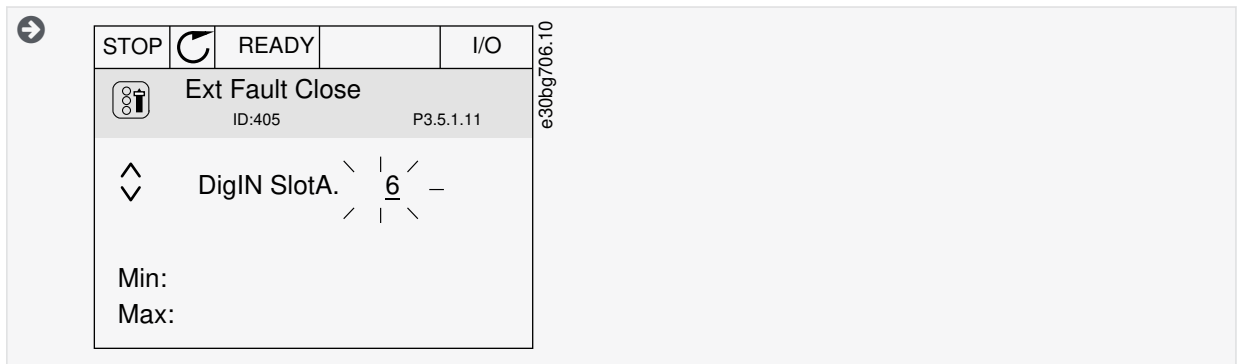

5. If the digital input DI6 was already used for some other function, a message shows on the display. Change one of these selections.

11.8.1.4 Programming of Digital Inputs in the Text Display

Procedure

1. Select a parameter. To go into the Edit mode, push the [OK] button.

- In the Edit mode, the letter D blinks. If there are more digital inputs available in the I/O, for example, because of option boards in slots C, D or E, select them.

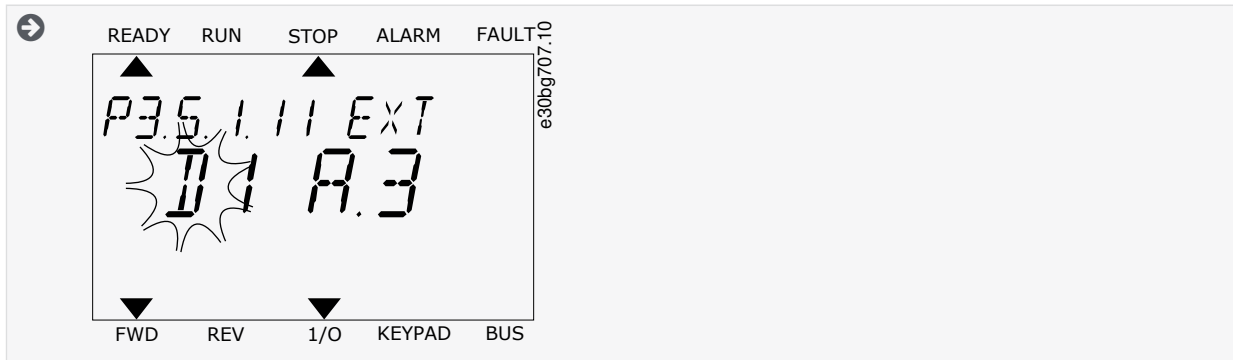

- To activate the terminal 3, push the arrow button Right again. The letter D stops blinking.
- To change the terminal to 6, push the arrow button Up 3 times. Accept the change with the [OK] button.

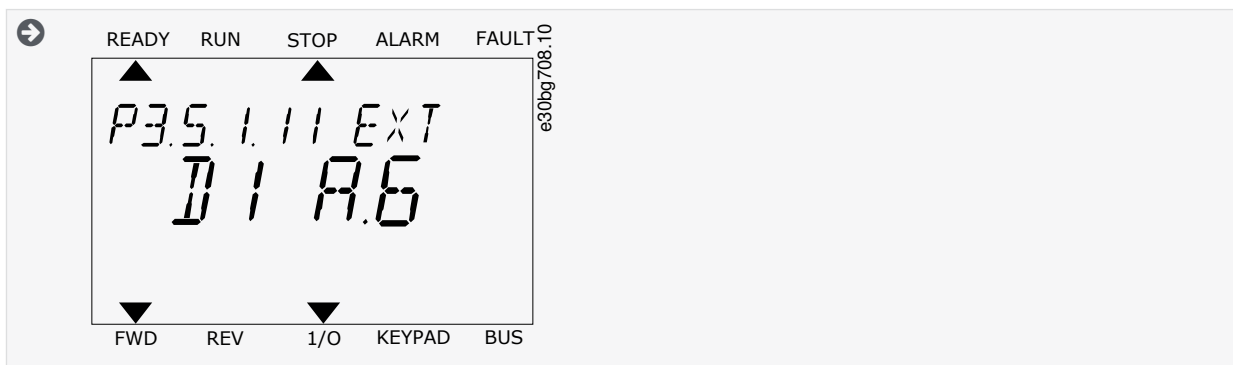

- If the digital input DI6 was already used for some other function, a message scrolls on the display. Change one of these selections.

It is also possible to give time channels to digital inputs. There is more data about it in [Table 89](#).

➔ After the steps, a digital signal to the digital input DI6 controls the function External Fault Close. The value of a function can be DigIN Slot0.1 (in the graphical display) or dl 0.1 (in the text display). In these conditions, a terminal was not given to the function, or the input was set to be always OPEN. It is the default value of most of parameters in the group M3.5.1. On the other hand, some inputs have the default value always CLOSED. Their value shows DigIN Slot0.2 in the graphical display and dl 0.2 in the text display.

11.8.1.5 Programming of Analog Inputs

It is possible to select the target input for the signal of the analog frequency reference from the available analog inputs.

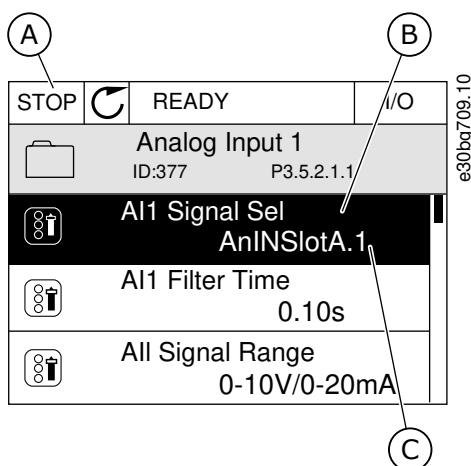

Illustration 43: The Analog Inputs Menu in the Graphical Display

A	The graphical display	C	The value of the parameter, that is, the set analog input
B	The name of the parameter		

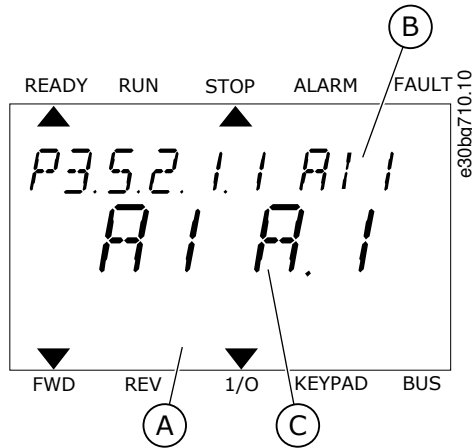

Illustration 44: The Analog Inputs Menu in the Text Display

A	The text display	C	The value of the parameter, that is, the set analog input
B	The name of the parameter		

Example

In the standard I/O board compilation, there are 2 analog inputs available: the slot A terminals 2/3 and 4/5.

Input type (graphical display)	Input type (text display)	Slot	Input #	Explanation
AnIN	AI	A	1	Analog input #1 (terminals 2/3) on a board in Slot A (standard I/O board).
AnIN	AI	A	2	Analog input #2 (terminals 4/5) on a board in Slot A (standard I/O board).

The location of the parameter P3.5.2.1.1 AI1 Signal Selection is the menu M3.5.2.1. The parameter gets the default value AnIN SlotA.1 in the graphical display or AI A.1 in the text display. The target input for the signal of the analog frequency reference AI1 is then the analog input in the terminals 2/3. Use the DIP switches to set the signal to be voltage or current. See the Installation manual for more data.

Index	Parameter	Default	ID	Description
P3.5.2.1.1	AI1 Signal Selection	AnIN SlotA.1	377	

To change the input from AI1 to, for example, the analog input on your option board in slot C, obey these instructions.

11.8.1.6 Programming of Analog Inputs in the Graphical Display

Procedure

1. To select the parameter, push the arrow button Right.

- In the Edit mode, the value AnIN SlotA is underlined and blinks.

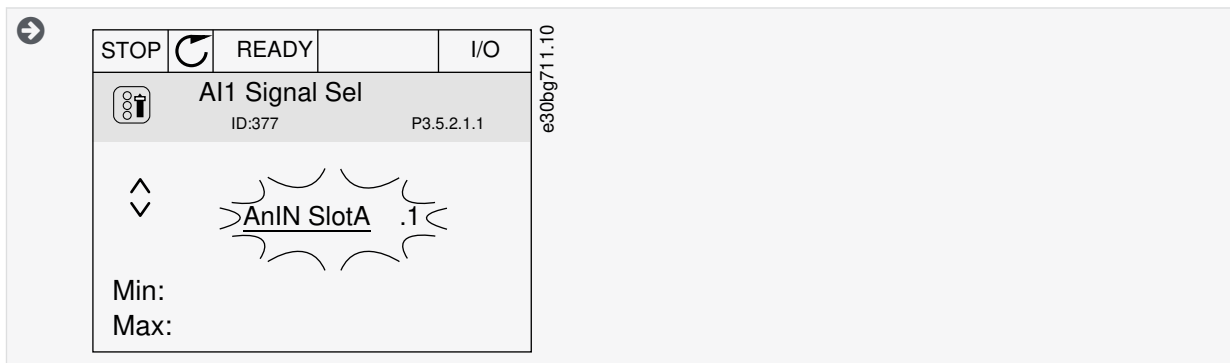

- To change the value to AnIN SlotC, push the arrow button Up. Accept the change with the [OK] button.

11.8.1.7 Programming of Analog Inputs in the Text Display

Procedure

- To select the parameter, push the [OK] button.
- In the Edit mode, the letter A blinks.

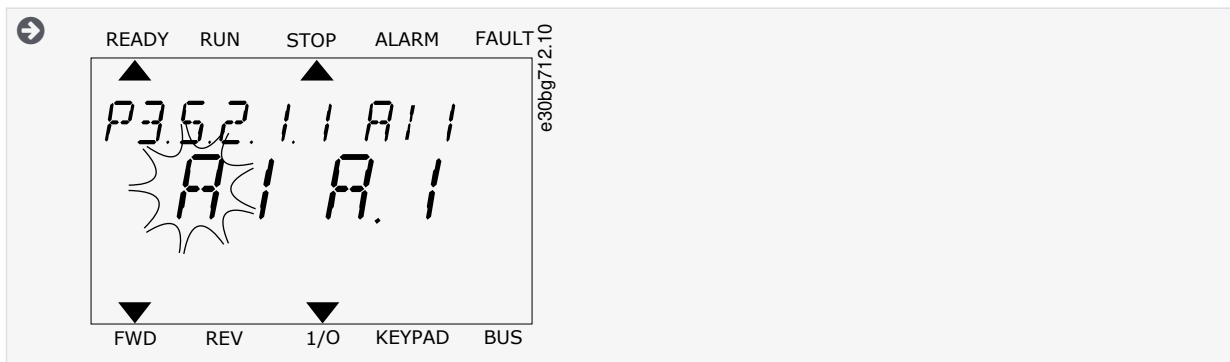

- To change the value to C, push the arrow button Up. Accept the change with the [OK] button.

11.8.2 Descriptions of Signal Sources

Table 132: Descriptions of Signal Sources

Source	Function
Slot0.#	<p>Digital inputs:</p> <p>Use this function to set a digital signal to be in a constant OPEN or CLOSED state. The manufacturer set some signals so that they are always in the CLOSED state, for example parameter P3.5.1.15 (Run Enable). The Run Enable signal is always on if it is not changed.</p> <p># = 1: Always OPEN # = 2-10: Always CLOSED</p> <p>Analog inputs (used for testing purposes):</p> <p># = 1: Analog input = 0% of the signal strength # = 2: Analog input = 20% of the signal strength # = 3: Analog input = 30% of the signal strength, and so on # = 10: Analog input = 100% of the signal strength</p>
SlotA.#	Number (#) agrees to a digital input in slot A.
SlotB.#	Number (#) agrees to a digital input in slot B.
SlotC.#	Number (#) agrees to a digital input in slot C.
SlotD.#	Number (#) agrees to a digital input in slot D.

Source	Function
SlotE.#	Number (#) agrees to a digital input in slot E.
TimeChannel.#	1=Time Channel1, 2=Time Channel2, 3=Time Channel3
FieldbusCW.#	Number (#) refers to a control word bit number.
FieldbusPD.#	Number (#) refers to the process data 1 bit number.
BlockOut.#	Number (#) refers to an output of the corresponding function block in the Drive customizer.

11.8.3 Default Functions of Programmable Inputs

Table 133: Default Functions of the Programmable Digital and Analog Inputs

Input	Terminal(s)	Reference	Function	Parameter index
DI1	8	A.1	Control Signal 1 A	P3.5.1.1
DI2	9	A.2	Control Signal 2 A	P3.5.1.2
DI3	10	A.3	External Fault Close	P3.5.1.11
DI4	14	A.4	Preset Frequency Selection 0	P3.5.1.21
DI5	15	A.5	Preset Frequency Selection 1	P3.5.1.22
DI6	16	A.6	Fault Reset Close	P3.5.1.13
AI1	2/3	A.1	AI1 Signal Selection	P3.5.2.1.1
AI2	4/5	A.2	AI2 Signal Selection	P3.5.2.2.1

11.8.4 Digital Inputs

The parameters are functions that can be connected to a digital input terminal. The text DigIn Slot A.2 means the second input on the slot A. It is also possible to connect the functions to time channels. The time channels work as terminals.

It is possible to monitor the statuses of the digital inputs and the digital outputs in the Multimonitoring view.

11.8.4.1 (ID 403) Control Signal 1 A

Location in the menu: **P3.5.1.1**

Use this parameter to select the digital input signal (Control Signal 1) that starts and stops the drive when the control place is I/O A (FWD).

11.8.4.2 (ID 404) Control Signal 2 A

Location in the menu: **P3.5.1.2**

Use this parameter to select the digital input signal (Control Signal 2) that starts and stops the drive when the control place is I/O A (REV).

11.8.4.3 (ID 434) Control Signal 3 A

Location in the menu: **P3.5.1.3**

Use this parameter to select the digital input signal (Control Signal 3) that starts and stops the drive when the control place is I/O A.

11.8.4.4 (ID 423) Control Signal 1 B

Location in the menu: **P3.5.1.4**

Use this parameter to select the digital input signal (Control Signal 1) that starts and stops the drive when the control place is I/O B.

11.8.4.5 (ID 424) Control Signal 2 B

Location in the menu: **P3.5.1.5**

Use this parameter to select the digital input signal (Control Signal 2) that starts and stops the drive when the control place is I/O B.

11.8.4.6 (ID 435) Control Signal 3 B

Location in the menu: **P3.5.1.6**

Use this parameter to select the digital input signal (Control Signal 3) that starts and stops the drive when the control place is I/O B.

11.8.4.7 (ID 425) I/O B Control Force

Location in the menu: **P3.5.1.7**

Use this parameter to select the digital input signal that switches the control place from I/O A to I/O B.

11.8.4.8 (ID 343) I/O B Reference Force

Location in the menu: **P3.5.1.8**

Use this parameter to select the digital input signal that switches the frequency reference source from I/O A to I/O B.

11.8.4.9 (ID 411) Fieldbus Control Force

Location in the menu: **P3.5.1.9**

Use this parameter to select the digital input signal that switches the control place and the frequency reference source to Fieldbus (from I/O A, I/O B or Local control).

11.8.4.10 (ID 410) Keypad Control Force

Location in the menu: **P3.5.1.10**

Use this parameter to select the digital input signal that switches the control place and the frequency reference source to Keypad (from any control place).

11.8.4.11 (ID 405) External Fault Close

Location in the menu: **P3.5.1.11**

Use this parameter to select the digital input signal that activates an external fault.

11.8.4.12 (ID 406) External Fault Open

Location in the menu: **P3.5.1.12**

Use this parameter to select the digital input signal that activates an external fault.

11.8.4.13 (ID 414) Fault Reset Close

Location in the menu: **P3.5.1.13**

Use this parameter to select the digital input signal that resets all active faults. Active faults are reset when the state of the digital input changes from open to closed (rising edge).

11.8.4.14 (ID 213) Fault Reset Open

Location in the menu: **P3.5.1.14**

Use this parameter to select the digital input signal that resets all active faults. Active faults are reset when the state of the digital input changes from closed to open (falling edge).

11.8.4.15 (ID 407) Run Enable

Location in the menu: **P3.5.1.15**

Use this parameter to select the digital input signal that sets the drive to Ready state. When the contact is OPEN, the start of the motor is disabled. When the contact is CLOSED, the start of the motor is enabled.

The state of the drive remains in 'Not Ready' if the state of this signal is 'opened'. If the Run Enable signal is used for stopping the drive, the drive will always coast to stop regardless of the selection in parameter P3.2.5 Stop Function.

11.8.4.16 (ID 1041) Run Interlock 1

Location in the menu: **P3.5.1.16**

Use this parameter to select the digital input signal that prevents to start the drive. The drive can be ready but start is not possible when the state of the interlock signal is 'open' (damper interlock).

11.8.4.17 (ID 1042) Run Interlock 2

Location in the menu: **P3.5.1.17**

Use this parameter to select the digital input signal that prevents starting the drive. The drive can be ready but start is not possible when the state of the interlock signal is 'open' (damper interlock).

If an interlock is active, the drive cannot start.

It is possible to use this function to prevent the start of the drive when the damper is closed. If an interlock is activated during the operation of the drive, the drive stops.

11.8.4.18 (ID 1044) Motor Preheat ON

Location in the menu: **P3.5.1.18**

Use this parameter to select the digital input signal that activates Motor Preheat function. The Motor Preheat function feeds DC-current to the motor when the drive is in the stop state.

11.8.4.19 (ID 408) Ramp 2 Selection

Location in the menu: **P3.5.1.19**

Use this parameter to select the digital input signal that selects the ramp time to be used.

11.8.4.20 (ID 415) Acc/Dec Prohibit

Location in the menu: **P3.5.1.20**

Use this parameter to select the digital input signal that prevents the acceleration and the deceleration of the drive. No acceleration or deceleration is possible until the contact is open.

11.8.4.21 (ID 419) Preset Frequency Selection 0

Location in the menu: **P3.5.1.21**

Use this parameter to set the digital input signal that selects the preset frequencies.

11.8.4.22 (ID 420) Preset Frequency Selection 1

Location in the menu: **P3.5.1.22**

Use this parameter to set the digital input signal that selects the preset frequencies.

11.8.4.23 (ID 421) Preset Frequency Selection 2

Location in the menu: **P3.5.1.23**

Use this parameter to set the digital input signal that selects the preset frequencies.

11.8.4.24 (ID 418) Motor Potentiometer Up

Location in the menu: **P3.5.1.24**

Use this parameter to increase the output frequency with a digital input signal. The motor potentiometer reference INCREASES until the contact is open.

11.8.4.25 (ID 417) Motor Potentiometer Down

Location in the menu: **P3.5.1.25**

Use this parameter to decrease the output frequency with a digital input signal. The motor potentiometer reference DECREASES until the contact is open.

11.8.4.26 (ID 1213) Quick Stop Activation

Location in the menu: **P3.5.1.26**

Use this parameter to select the digital input signal that activates a Quick Stop function. The Quick Stop function stops the drive regardless of the control place or the state of the control signals.

11.8.4.27 (ID 447) Timer 1

Location in the menu: **P3.5.1.27**

Use this parameter to select the digital input signal that starts the timer. The timer starts when this signal is deactivated (falling edge). The output is deactivated when the time defined in the duration parameter has elapsed.

11.8.4.28 (ID 448) Timer 2

Location in the menu: **P3.5.1.28**

Use this parameter to select the digital input signal that starts the timer. The timer starts when this signal is deactivated (falling edge). The output is deactivated when the time defined in the duration parameter has elapsed.

11.8.4.29 (ID 449) Timer 3

Location in the menu: **P3.5.1.29**

Use this parameter to select the digital input signal that starts the timer. The timer starts when this signal is deactivated (falling edge). The output is deactivated when the time defined in the duration parameter has elapsed.

11.8.4.30 (ID 1046) PID Setpoint Boost

Location in the menu: **P3.5.1.30**

Use this parameter to select the digital input signal that activates the boost for the PID setpoint value. The timer starts when this signal is deactivated (falling edge). The output is deactivated when the time defined in the duration parameter has elapsed.

11.8.4.31 (ID 1047) PID Setpoint Selection

Location in the menu: **P3.5.1.31**

Use this parameter to set the digital input signal that selects the PID setpoint value to be used.

11.8.4.32 (ID 1049) External PID Start Signal

Location in the menu: **P3.5.1.32**

Use this parameter to select the digital input signal that starts and stops the external PID controller.

NOTICE

This parameter has no effect if the external PID controller is not enabled in Group 3.14.

11.8.4.33 (ID 1048) External PID Setpoint Selection

Location in the menu: **P3.5.1.33**

Use this parameter to set the digital input signal that selects the PID setpoint value to be used.

11.8.4.34 (ID 426) Motor 1 Interlock

Location in the menu: **P3.5.1.34**

Use this parameter to select the digital input signal that is used as interlock signal for the multi-pump system.

11.8.4.35 (ID 427) Motor 2 Interlock

Location in the menu: **P3.5.1.35**

Use this parameter to select the digital input signal that is used as interlock signal for the multi-pump system.

11.8.4.36 (ID 428) Motor 3 Interlock

Location in the menu: **P3.5.1.36**

Use this parameter to select the digital input signal that is used as interlock signal for the multi-pump system.

11.8.4.37 (ID 429) Motor 4 Interlock

Location in the menu: **P3.5.1.37**

Use this parameter to select the digital input signal that is used as interlock signal for the multi-pump system.

11.8.4.38 (ID 430) Motor 5 Interlock

Location in the menu: **P3.5.1.38**

Use this parameter to select the digital input signal that is used as interlock signal for the multi-pump system.

11.8.4.39 (ID 486) Motor 6 Interlock

Location in the menu: **P3.5.1.39**

Use this parameter to select the digital input signal that is used as interlock signal for the multi-pump system.

11.8.4.40 (ID 490) Reset Maintenance Counter

Location in the menu: **P3.5.1.40**

Use this parameter to select the digital input that reset the value of the Maintenance Counter.

11.8.4.41 (ID 532) Enable DI Jogging

Location in the menu: **P3.5.1.41**

Use this parameter to enable the jogging commands from digital inputs. This parameter does not affect the jogging from fieldbus.

11.8.4.42 (ID 530) Jogging Reference 1 Activation

Location in the menu: **P3.5.1.42**

Use this parameter to set the digital input signals that activate the Jogging function.

NOTICE

If the input is activated, the drive starts.

11.8.4.43 (ID 531) Jogging Reference 2 Activation

Location in the menu: **P3.5.1.43**

Use this parameter to set the digital input signals that activate the Jogging function.

NOTICE

If the input is activated, the drive starts.

11.8.4.44 (ID 1210) Mechanical Brake Feedback

Location in the menu: **P3.5.1.44**

Use this parameter to set the brake status feedback signal from mechanical brake. Connect this input signal to the auxiliary contact of the mechanical brake. If the contact is not closed within the given time, the drive shows a fault.

11.8.4.45 (ID 1596) Fire Mode Activation OPEN

Location in the menu: **P3.5.1.45**

Use this parameter to select the digital input signal that activates the Fire Mode function. This parameter activates the Fire Mode if it is enabled with a correct password.

11.8.4.46 (ID 1619) Fire Mode Activation CLOSE

Location in the menu: **P3.5.1.46**

Use this parameter to select the digital input signal that activates the Fire Mode function. This parameter activates the Fire Mode if it is enabled with a correct password.

11.8.4.47 (ID 1618) Fire Mode Reverse

Location in the menu: **P3.5.1.47**

Use this parameter to select the digital input signal that gives a command for reverse rotation direction during the Fire Mode. This function has no effect in normal operation.

11.8.4.48 (ID 1715) Auto-Cleaning Activation

Location in the menu: **P3.5.1.48**

Use this parameter to select the digital input signal that starts the Auto-cleaning. The Auto-cleaning stops if the activation signal is removed before the process is complete.

N O T I C E

If the input is activated, the drive starts.

11.8.4.49 (ID 496) Parameter Set 1/2 Selection

Location in the menu: **P3.5.1.49**

Use this parameter to set the digital input that selects the parameter set to be used. This function is enabled if any other slot than 'DigIN Slot0' is selected to this parameter. The parameter set selection is allowed only when the drive is stopped.

- Contact Open = Parameter Set 1 is loaded as the active set
- Contact Closed = Parameter Set 2 is loaded as the active set

Parameter values are stored to Set 1 and Set 2 by parameters B6.5.4 Save to Set 1 and B6.5.4 Save to Set 2. These parameters can be used either from keypad or VACON[®]Live PC tool.

11.8.4.50 (ID 15523) User Defined Fault 1

- Location in the menu: **P3.5.1.50** (In I/O Configuration parameter menu)
- Location in the menu: **P3.9.9.1** (In Protections parameter menu)

Use this parameter to set the digital input signal that activates User Defined Fault 1 (Fault ID 1114).

11.8.4.51 (ID 15524) User Defined Fault 2

- Location in the menu: **P3.5.1.51** (In I/O Configuration parameter menu)
- Location in the menu: **P3.9.10.1** (In Protections parameter menu)

Use this parameter to set the digital input signal that activates User Defined Fault 2 (Fault ID 1115).

11.8.4.52 (ID 15513) AHF Over Temperature

- Location in the menu: **P3.5.1.52** (In I/O Configuration parameter menu)
- Location in the menu: **P3.22.3** (In Advanced Harmonic Filter parameter menu)

Use this parameter to set the digital input signal that activates AHF Over Temp (fault ID 1118).

11.8.5 Analog Inputs

11.8.5.1 (ID 377) AI1 Signal Selection

Location in the menu: **P3.5.2.1.1**

Use this parameter to connect the AI signal to the analog input of your selection.

This parameter is programmable. See [11.8.3 Default Functions of Programmable Inputs](#).

11.8.5.2 (ID 378) AI1 Signal Filter Time

Location in the menu: **P3.5.2.1.2**

Use this parameter to filter out disturbances in the analog input signal. To activate this parameter, enter a value greater than 0.

N O T I C E

A long filter time makes the regulation response slow.

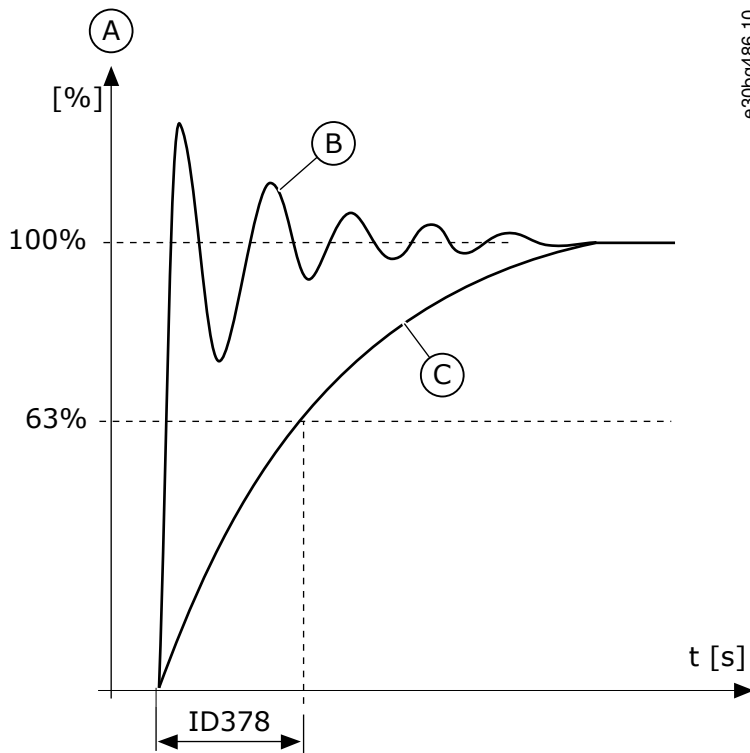

Illustration 45: The AI1 Signal Filtering

A	Analog input signal	C	Filtered signal
B	Unfiltered signal		

11.8.5.3 (ID 379) AI1 Signal Range

Location in the menu: **P3.5.2.1.3**

Use this parameter to change the range of the analog signal. The value of this parameter is bypassed if the custom scaling parameters are used.

Use the DIP switches on the control board to set the type of the analog input signal (current or voltage). For more information, see the Installation manual. It is also possible to use the analog input signal as frequency reference. The selection of the value 0 or 1 change the scaling of the analog input signal.

Selection number	Selection name	Description
0	0...10 V/0...20 mA	The range of the analog input signal is 0...10 V or 0...20 mA (the DIP switch settings on the control board tell which one). The input signal is 0...100%.
1	2...10 V/4...20 mA	The range of the analog input signal is 2...10 V or 4...20 mA (the DIP switch settings on the control board tell which one). The input signal is 20...100%.

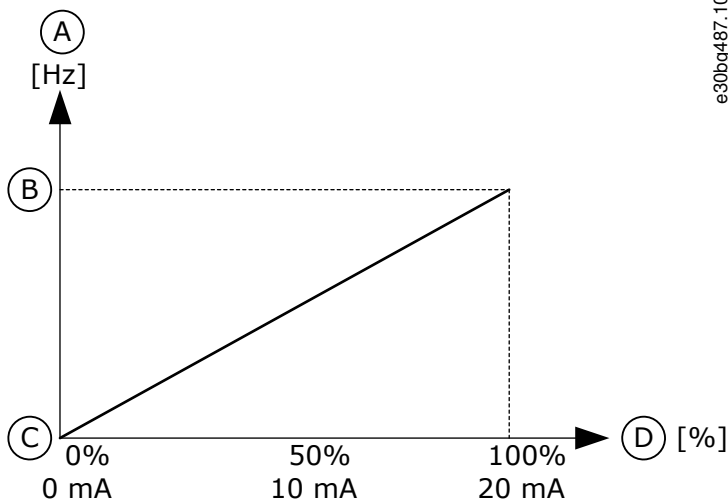

Illustration 46: The Analog Input Signal Range, Selection 0

A	Frequency reference	C	Min freq reference
B	Max freq reference	D	Analog input signal

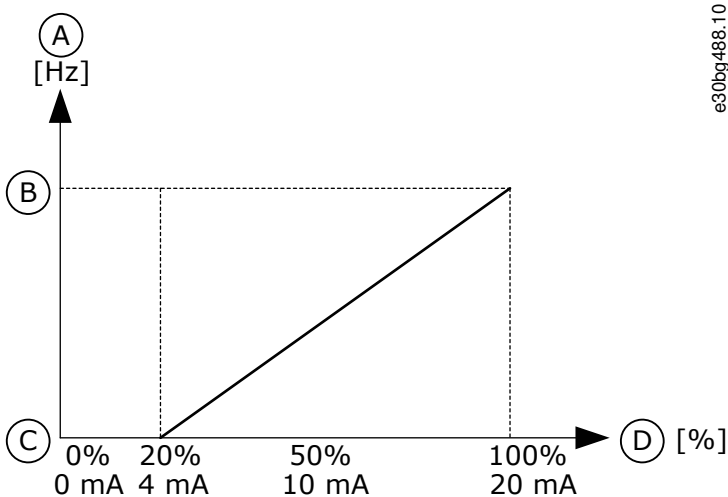

Illustration 47: The Analog Input Signal Range, Selection 1

A	Frequency reference	C	Min freq reference
B	Max freq reference	D	Analog input signal

11.8.5.4 (ID 380) AI1 Custom. MIN

Location in the menu: P3.5.2.1.4

Use this parameter to adjust the range of the analog input signal between -160% and 160%.

11.8.5.5 (ID 381) AI1 Custom. MAX

Location in the menu: P3.5.2.1.5

Use this parameter to adjust the range of the analog input signal between -160% and 160%.

Use the analog input signal, for example, as frequency reference, and set the parameters P3.5.2.1.4 and P3.5.2.1.5 between 40 and 80%. In these conditions, the frequency reference changes between the Minimum frequency reference and the Maximum frequency reference, and the analog input signal changes between 8 and 16 mA.

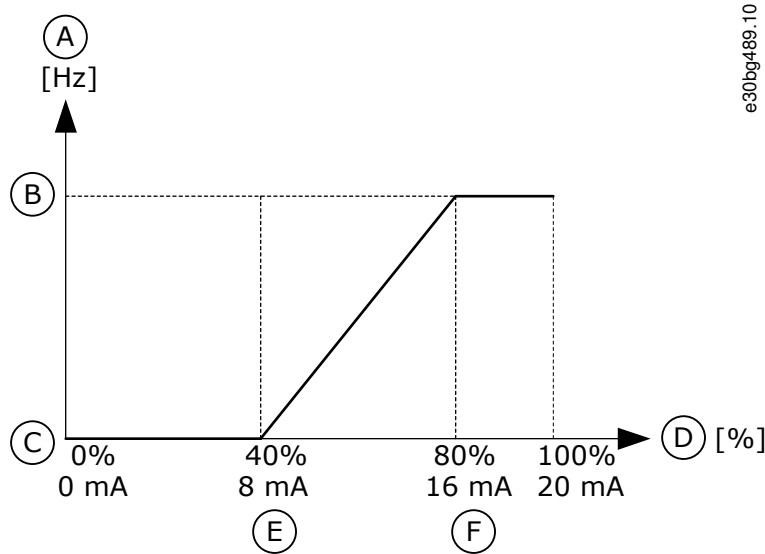

Illustration 48: AI1 Signal Custom. Min/Max

A	Frequency reference	D	Analog input signal
B	Max freq reference	E	AI custom min
C	Min freq reference	F	AI custom max

11.8.5.6 (ID 387) AI1 Signal Inversion

Location in the menu: **P3.5.2.1.6**

Use this parameter to invert the analog input signal. When the analog input signal is inverted, the curve of the signal becomes the opposite.

It is possible to use the analog input signal as frequency reference. The selection of the value 0 or 1 change scaling of the analog input signal.

Selection number	Selection name	Description
0	Normal	No inversion. The value 0% of the analog input signal agrees to the Minimum Frequency Reference. The value 100% of the analog input signal agrees to the Maximum Frequency Reference.
1	Inverted	Signal inversion. The value 0% of the analog input signal agrees to the Maximum Frequency Reference. The value 100% of the analog input signal agrees to the Minimum Frequency Reference.

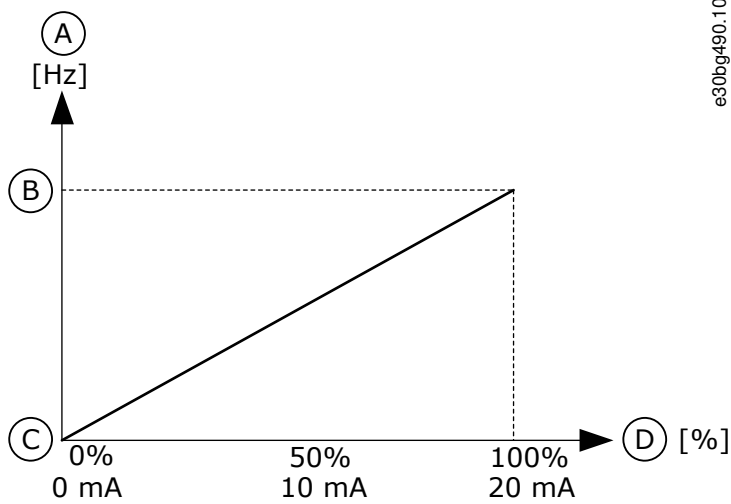

Illustration 49: AI1 Signal Inversion, Selection 0

A	Frequency reference	C	Minimum frequency reference
B	Maximum frequency reference	D	Analog input signal

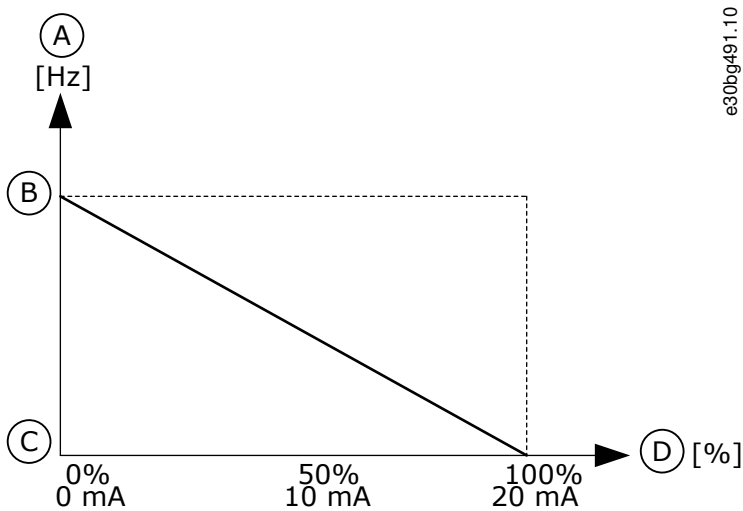

Illustration 50: AI1 Signal Inversion, Selection 1

A	Frequency reference	C	Minimum frequency reference
B	Maximum frequency reference	D	Analog input signal

11.8.6 Digital Outputs

11.8.6.1 (ID 11001) RO1 Function

Location in the menu: **P3.5.3.2.1**

Use this parameter to select a function or a signal that is connected to the relay output.

Selection number	Selection name	Description
0	Not used	The output is not used.
1	Ready	The AC drive is ready to operate.
2	Run	The AC drive operates (the motor runs).
3	General fault	A fault trip occurred.
4	General fault inverted	A fault trip did not occur.
5	General alarm	An alarm occurred.
6	Reversed	The reverse command is given.
7	At speed	The output frequency has become the same as the set frequency reference.
8	Thermistor fault	A thermistor fault occurred.
9	Motor regulator activated	One of the limit regulators (for example current limit or torque limit) is activated.
10	Start signal active	The start command of the drive is active.
11	Keypad control active	The selection is keypad control (the active control place is keypad).
12	I/O control B active	The selection is I/O control place B (the active control place is I/O B).
13	Limit supervision 1	The limit supervision activates if the signal value goes below or above the set supervision limit (P3.8.3 or P3.8.7).
14	Limit supervision 2	The limit supervision activates if the signal value goes below or above the set supervision limit (P3.8.3 or P3.8.7).
15	Fire mode active	The Fire mode function is active.
16	Jogging active	The Jogging function is active.
17	Preset Frequency active	The selection of preset frequency was made with digital input signals.
18	Quick Stop active	The Quick stop function is activated.
19	PID in Sleep mode	The PID controller is in the sleep mode.
20	PID Soft Fill activated	The Soft fill function of the PID controller is activated.
21	PID feedback supervision	The feedback value of the PID controller is not in the supervision limits.
22	ExtPID feedback supervision	The External PID controller feedback value is not in the supervision limits.
23	Input pressure alarm	The input pressure of the pump is below the value that was set with parameter P3.13.9.7.
24	Frost protection alarm	The measured temperature of the pump is below the level that was set with parameter P3.13.10.5.
25	Motor 1 control	The contactor control for the Multi-pump function.
26	Motor 2 control	The contactor control for the Multi-pump function.
27	Motor 3 control	The contactor control for the Multi-pump function.
28	Motor 4 control	The contactor control for the Multi-pump function.
29	Motor 5 control	The contactor control for the Multi-pump function.

Selection number	Selection name	Description
30	Motor 6 control	The contactor control for the Multi-pump function.
31	Time channel 1	The status of Time channel 1.
32	Time channel 2	The status of Time channel 2.
33	Time channel 3	The status of Time channel 3.
34	Fieldbus Control Word bit 13	The digital (relay) output control from the Fieldbus control word bit 13.
35	Fieldbus Control Word bit 14	The digital (relay) output control from the Fieldbus control word bit 14.
36	Fieldbus Control Word bit 15	The digital (relay) output control from the Fieldbus control word bit 15.
37	Fieldbus Process Data In1 bit 0	The digital (relay) output control from the Fieldbus Process Data In1, bit 0.
38	Fieldbus Process Data In1 bit 1	The digital (relay) output control from the Fieldbus Process Data In1, bit 1.
39	Fieldbus Process Data In1 bit 2	The digital (relay) output control from the Fieldbus Process Data In1, bit 2.
40	Maintenance counter 1 alarm	The maintenance counter reached the alarm limit that is set with parameter P3.16.2.
41	Maintenance counter 1 fault	The maintenance counter reached the alarm limit that is set with parameter P3.16.3.
42	Mechanical brake control	The Open mechanical brake command.
43	Mechanical brake control (Inverted)	The Open mechanical brake command (inverted).
44	Block Out.1	The output of the programmable Block 1. See parameter menu M3.19 Drive customizer.
45	Block Out.2	The output of the programmable Block 2. See parameter menu M3.19 Drive customizer.
46	Block Out.3	The output of the programmable Block 3. See parameter menu M3.19 Drive customizer.
47	Block Out.4	The output of the programmable Block 4. See parameter menu M3.19 Drive customizer.
48	Block Out.5	The output of the programmable Block 5. See parameter menu M3.19 Drive customizer.
49	Block Out.6	The output of the programmable Block 6. See parameter menu M3.19 Drive customizer.
50	Block Out.7	The output of the programmable Block 7. See parameter menu M3.19 Drive customizer.
51	Block Out.8	The output of the programmable Block 8. See parameter menu M3.19 Drive customizer.
52	Block Out.9	The output of the programmable Block 9. See parameter menu M3.19 Drive customizer.
53	Block Out.10	The output of the programmable Block 10. See parameter menu M3.19 Drive customizer.
54	Jockey pump control	The control signal for the external jockey pump.

Selection number	Selection name	Description
55	Priming pump control	The control signal for the external priming pump.
56	Auto-cleaning active	The Pump auto-cleaning function is activated.
57	Motor Switch Open	The Motor Switch function has detected that the switch between the drive and the motor is open.
58	TEST (Always Closed)	
59	Motor preheat active	
60	AHF Capacitor Disconnect	
61	AHF Capacitor Disconnect Inverted	
62	Run Indication	

11.8.6.2 (ID 11002) RO1 ON Delay

Location in the menu: **P3.5.3.2.2**

Use this parameter to set the ON delay for the relay output.

11.8.6.3 (ID 11003) RO1 OFF Delay

Location in the menu: **P3.5.3.2.3**

Use this parameter to set the OFF delay for the relay output.

11.8.6.4 (ID 11004) RO2 Function

Location in the menu: **P3.5.3.2.4**

Use this parameter to select a function or a signal that is connected to the relay output. See [11.8.6.1 \(ID 11001\) RO1 Function](#).

11.8.6.5 (ID 11005) RO2 ON Delay

Location in the menu: **P3.5.3.2.5**

Use this parameter to set the ON delay for the relay output.

11.8.6.6 (ID 11006) RO2 OFF Delay

Location in the menu: **P3.5.3.2.6**

Use this parameter to set the OFF delay for the relay output.

11.8.6.7 (ID 11007) RO3 Function

Location in the menu: **P3.5.3.2.7**

Use this parameter to select a function or a signal that is connected to the relay output. The parameter is not visible if only 2 output relays are installed. See [11.8.6.1 \(ID 11001\) RO1 Function](#).

11.8.6.8 (ID 11008) RO3 ON Delay

Location in the menu: **P3.5.3.2.8**

Use this parameter to set the ON delay for the relay output. The parameter is not visible if only 2 output relays are installed.

11.8.6.9 (ID 11009) RO3 OFF Delay

Location in the menu: **P3.5.3.2.9**

Use this parameter to set the OFF delay for the relay output. The parameter is not visible if only 2 output relays are installed.

11.8.7 Analog Outputs

11.8.7.1 (ID 10050) AO1 Function

Location in the menu: P3.5.4.1.1

Use this parameter to select a function or a signal that is connected to the analog output. The contents of the analog output signal 1 are specified in this parameter. The scaling of the analog output signal depends on the signal.

Selection number	Selection name	Description
0	Test 0% (Not used)	The analog output is set to 0% or 20% so that it agrees with parameter P3.5.4.1.3.
1	TEST 100%	The analog output is set to 100% of the signal (10 V/20 mA).
2	Output frequency	The actual output frequency from 0 to Maximum frequency reference.
3	Frequency reference	The actual frequency reference from 0 to Maximum frequency reference.
4	Motor speed	The actual motor speed from 0 to Motor nominal speed.
5	Output current	The output current of the drive from 0 to Motor nominal current.
6	Motor torque	The actual motor torque from 0 to motor nominal torque (100%).
7	Motor power	The actual motor power from 0 to Motor nominal power (100%).
8	Motor voltage	The actual motor voltage from 0 to Motor nominal voltage.
9	DC link voltage	The actual DC link voltage 0...1000 V.
10	PID Setpoint	The actual setpoint value of the PID Controller (0...100%).
11	PID Feedback	The actual feedback value of the PID Controller (0...100%).
12	PID output	The output of the PID controller (0...100%).
13	ExtPID output	The External PID controller output (0...100%).
14	Fieldbus Process Data In 1	Fieldbus Process Data In 1: 0...10000 (this agrees with 0... 100.00%).
15	Fieldbus Process Data In 2	Fieldbus Process Data In 2: 0...10000 (this agrees with 0... 100.00%).
16	Fieldbus Process Data In 3	Fieldbus Process Data In 3: 0...10000 (this agrees with 0... 100.00%).
17	Fieldbus Process Data In 4	Fieldbus Process Data In 4: 0...10000 (this agrees with 0... 100.00%).
18	Fieldbus Process Data In 5	Fieldbus Process Data In 5: 0...10000 (this agrees with 0... 100.00%).
19	Fieldbus Process Data In 6	Fieldbus Process Data In 6: 0...10000 (this agrees with 0... 100.00%).
20	Fieldbus Process Data In 7	Fieldbus Process Data In 7: 0...10000 (this agrees with 0... 100.00%).
21	Fieldbus Process Data In 8	Fieldbus Process Data In 8: 0...10000 (this agrees with 0... 100.00%).
22	Block Out.1	The output of the programmable Block 1: 0...10000 (this agrees with 0...100.00%). See parameter menu M3.19 Drive customizer.

Selection number	Selection name	Description
23	Block Out.2	The output of the programmable Block 2: 0...10000 (this agrees with 0...100.00%). See parameter menu M3.19 Drive customizer.
24	Block Out.3	The output of the programmable Block 3: 0...10000 (this agrees with 0...100.00%). See parameter menu M3.19 Drive customizer.
25	Block Out.4	The output of the programmable Block 4: 0...10000 (this agrees with 0...100.00%). See parameter menu M3.19 Drive customizer.
26	Block Out.5	The output of the programmable Block 5: 0...10000 (this agrees with 0...100.00%). See parameter menu M3.19 Drive customizer.
27	Block Out.6	The output of the programmable Block 6: 0...10000 (this agrees with 0...100.00%). See parameter menu M3.19 Drive customizer.
28	Block Out.7	The output of the programmable Block 7: 0...10000 (this agrees with 0...100.00%). See parameter menu M3.19 Drive customizer.
29	Block Out.8	The output of the programmable Block 8: 0...10000 (this agrees with 0...100.00%). See parameter menu M3.19 Drive customizer.
30	Block Out.9	The output of the programmable Block 9: 0...10000 (this agrees with 0...100.00%). See parameter menu M3.19 Drive customizer.
31	Block Out.10	The output of the programmable Block 10: 0...10000 (this agrees with 0...100.00%). See parameter menu M3.19 Drive customizer.

11.8.7.2 (ID 10051) AO1 Filter Time

Location in the menu: **P3.5.4.1.2**

Use this parameter to set the filtering time for the analog signal. The filtering function is disabled when the filtering time is 0. See P3.5.2.1.2.

11.8.7.3 (ID 10052) AO1 Minimum

Location in the menu: **P3.5.4.1.3**

Use this parameter to change the range of the analog output signal. For example, if '4 mA' is selected, the range of analog output signal is 4...20 mA. Select the signal type (current/voltage) with the DIP switches. The analog output scaling is different in P3.5.4.1.4. See also P3.5.2.1.3.

11.8.7.4 (ID 10053) AO1 Minimum Scale

Location in the menu: **P3.5.4.1.4**

Use this parameter to scale the analog output signal. The scaling values (min and max) are given in the process unit specified by the selection of the AO function.

11.8.7.5 (ID 10054) AO1 Maximum Scale

Location in the menu: **P3.5.4.1.5**

Use this parameter to scale the analog output signal. The scaling values (min and max) are given in the process unit specified by the selection of the AO function.

Select, for example, the output frequency of the drive for the contents of the analog output signal, and set parameters P3.5.4.1.4 and P3.5.4.1.5 between 10 and 40 Hz. Then the output frequency of the drive changes between 10 and 40 Hz, and the analog output signal changes between 0 and 20 mA.

e30bg492.10

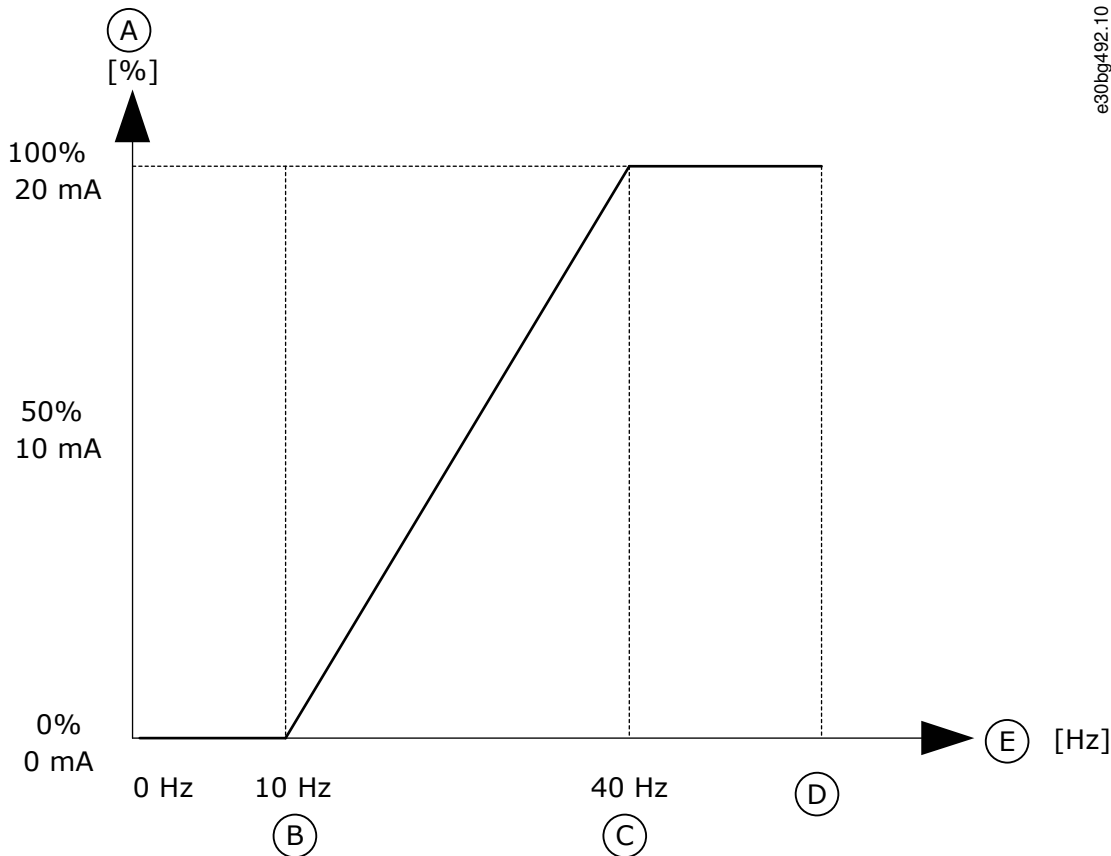

Illustration 51: Scaling of the AO1 Signal

A	Analog output signal	D	Maximum frequency reference
B	Analog output minimum scale	E	Output frequency
C	Analog output maximum scale		

11.9 Fieldbus Data

11.9.1 (ID 852) FB DataOut 1 Selection

Location in the menu: **P3.6.1**

Use this parameter to select the data that is sent to the fieldbus with the ID number of the parameter or monitor value.

The data is scaled to an unsigned 16-bit format according to the format on the control panel. For example, value 25.5 on the display equals 255.

11.9.2 (ID 853) FB DataOut 2 Selection

Location in the menu: **P3.6.2**

Use this parameter to select the data that is sent to the fieldbus with the ID number of the parameter or monitor value.

The data is scaled to an unsigned 16-bit format according to the format on the control panel. For example, value 25.5 on the display equals 255.

11.9.3 (ID 854) FB DataOut 3 Selection

Location in the menu: **P3.6.3**

Use this parameter to select the data that is sent to the fieldbus with the ID number of the parameter or monitor value.

The data is scaled to an unsigned 16-bit format according to the format on the control panel. For example, value 25.5 on the display equals 255.

11.9.4 (ID 855) FB DataOut 4 Selection

Location in the menu: **P3.6.4**

Use this parameter to select the data that is sent to the fieldbus with the ID number of the parameter or monitor value.

The data is scaled to an unsigned 16-bit format according to the format on the control panel. For example, value 25.5 on the display equals 255.

11.9.5 (ID 856) FB DataOut 5 Selection

Location in the menu: **P3.6.5**

Use this parameter to select the data that is sent to the fieldbus with the ID number of the parameter or monitor value.

The data is scaled to an unsigned 16-bit format according to the format on the control panel. For example, value 25.5 on the display equals 255.

11.9.6 (ID 857) FB DataOut 6 Selection

Location in the menu: **P3.6.6**

Use this parameter to select the data that is sent to the fieldbus with the ID number of the parameter or monitor value.

The data is scaled to an unsigned 16-bit format according to the format on the control panel. For example, value 25.5 on the display equals 255.

11.9.7 (ID 858) FB DataOut 7 Selection

Location in the menu: **P3.6.7**

Use this parameter to select the data that is sent to the fieldbus with the ID number of the parameter or monitor value.

The data is scaled to an unsigned 16-bit format according to the format on the control panel. For example, value 25.5 on the display equals 255.

11.9.8 (ID 859) FB DataOut 8 Selection

Location in the menu: **P3.6.8**

Use this parameter to select the data that is sent to the fieldbus with the ID number of the parameter or monitor value.

The data is scaled to an unsigned 16-bit format according to the format on the control panel. For example, value 25.5 on the display equals 255.

11.9.9 (ID 890) FB DataOut 9 Selection

Location in the menu: **P3.6.9**

Use this parameter to select the data that is sent to the fieldbus with the ID number of the parameter or monitor value.

The data is scaled to an unsigned 16-bit format according to the format on the control panel. For example, value 25.5 on the display equals 255.

11.9.10 (ID 891) FB DataOut 10 Selection

Location in the menu: **P3.6.10**

Use this parameter to select the data that is sent to the fieldbus with the ID number of the parameter or monitor value.

The data is scaled to an unsigned 16-bit format according to the format on the control panel. For example, value 25.5 on the display equals 255.

11.9.11 (ID 892) FB DataOut 11 Selection

Location in the menu: **P3.6.11**

Use this parameter to select the data that is sent to the fieldbus with the ID number of the parameter or monitor value.

The data is scaled to an unsigned 16-bit format according to the format on the control panel. For example, value 25.5 on the display equals 255.

11.9.12 (ID 893) FB DataOut 12 Selection

Location in the menu: **P3.6.12**

Use this parameter to select the data that is sent to the fieldbus with the ID number of the parameter or monitor value.

The data is scaled to an unsigned 16-bit format according to the format on the control panel. For example, value 25.5 on the display equals 255.

11.9.13 (ID 894) FB DataOut 13 Selection

Location in the menu: **P3.6.13**

Use this parameter to select the data that is sent to the fieldbus with the ID number of the parameter or monitor value.

The data is scaled to an unsigned 16-bit format according to the format on the control panel. For example, value 25.5 on the display equals 255.

11.9.14 (ID 895) FB DataOut 14 Selection

Location in the menu: **P3.6.14**

Use this parameter to select the data that is sent to the fieldbus with the ID number of the parameter or monitor value.

The data is scaled to an unsigned 16-bit format according to the format on the control panel. For example, value 25.5 on the display equals 255.

11.9.15 (ID 896) FB DataOut 15 Selection

Location in the menu: **P3.6.15**

Use this parameter to select the data that is sent to the fieldbus with the ID number of the parameter or monitor value.

The data is scaled to an unsigned 16-bit format according to the format on the control panel. For example, value 25.5 on the display equals 255.

11.9.16 (ID 897) FB DataOut 16 Selection

Location in the menu: **P3.6.16**

Use this parameter to select the data that is sent to the fieldbus with the ID number of the parameter or monitor value.

The data is scaled to an unsigned 16-bit format according to the format on the control panel. For example, value 25.5 on the display equals 255.

11.9.17 (ID 888) Fieldbus Sign of Actual

Location in the menu: **P3.6.17**

Use this parameter to select the behavior for the sign of the fieldbus Speed Actual.

Selection number	Selection name	Description
0	Positive	The sign of the actual is always positive. The running direction is visible from the status word bit 2. A TRUE value corresponds to reversing actual speed.
1	Actual direction	The sign of the actual follows the running direction. Forward is positive, reverse is negative. A TRUE value for status word bit 2 indicates if the direction of the actual differs from the direction requested from FB control commands.
2	Follow reference	A negative sign of the actual indicates if the direction of the actual differs from the direction requested from FB control commands. The status word bit 2 corresponds to the direction requested from FB control commands. A TRUE value corresponds to requested reversing.

11.10 Prohibit Frequencies

11.10.1 The Prohibit Frequencies Function

In some processes, it can be necessary to avoid some frequencies because they make problems of mechanical resonance. With the Prohibit frequencies function, it is possible to prevent the usage of these frequencies. When the input frequency reference increases, the internal frequency reference stays at the low limit, until the input frequency reference is above the high limit.

11.10.2 (ID 509) Prohibit Frequency Range 1 Low Limit

Location in the menu: **P3.7.1**

Use this parameter to prevent the drive operating on the prohibited frequencies.

In some processes, it can be necessary to avoid some frequencies because they cause mechanical resonance.

11.10.3 (ID 510) Prohibit Frequency Range 1 High Limit

Location in the menu: **P3.7.2**

Use this parameter to prevent the drive operating on the prohibited frequencies. In some processes, it can be necessary to avoid some frequencies because they cause mechanical resonance.

11.10.4 (ID 511) Prohibit Frequency Range 2 Low Limit

Location in the menu: **P3.7.3**

Use this parameter to prevent the drive operating on the prohibited frequencies. In some processes, it can be necessary to avoid some frequencies because they cause mechanical resonance.

11.10.5 (ID 512) Prohibit Frequency Range 2 High Limit

Location in the menu: **P3.7.4**

Use this parameter to prevent the drive operating on the prohibited frequencies. In some processes, it can be necessary to avoid some frequencies because they cause mechanical resonance.

11.10.6 (ID 513) Prohibit Frequency Range 3 Low Limit

Location in the menu: **P3.7.5**

Use this parameter to prevent the drive operating on the prohibited frequencies. In some processes, it can be necessary to avoid some frequencies because they cause mechanical resonance.

11.10.7 (ID 514) Prohibit Frequency Range 3 High Limit

Location in the menu: **P3.7.6**

Use this parameter to prevent the drive operating on the prohibited frequencies. In some processes, it can be necessary to avoid some frequencies because they cause mechanical resonance.

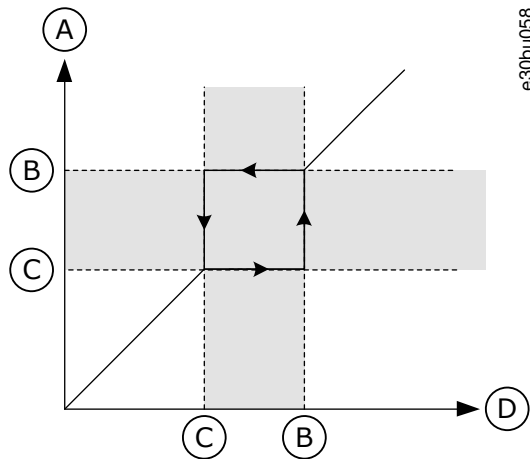

Illustration 52: The Prohibited Frequencies

A	Actual Reference	C	Low Limit
B	High Limit	D	Requested Reference

11.10.8 (ID 518) Ramp Time Factor

Location in the menu: **P3.7.7**

Use this parameter to set the multiplier of the selected ramp times when the output frequency of the drive is between the prohibited frequency limits. The Ramp Time Factor sets the acceleration and the deceleration time when the output frequency is in a prohibited frequency range. The value of the Ramp Time Factor is multiplied by the value of P3.4.1.2 (Acceleration Time 1) or P3.4.1.3 (Deceleration Time 1). For example, the value 0.1 makes the acceleration/deceleration time ten times shorter.

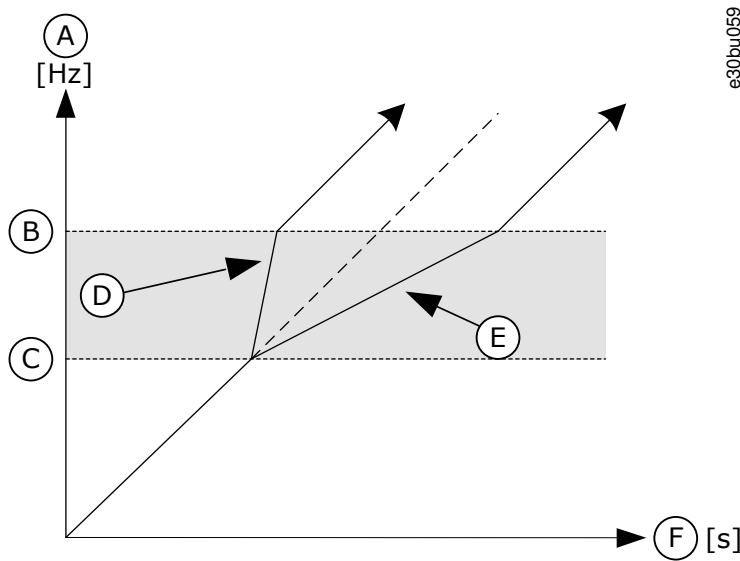

e30bu059

Illustration 53: The Parameter Ramp Time Factor

A	Output Frequency	D	Ramp Time Factor = 0.3
B	High Limit	E	Ramp Time Factor = 2.5
C	Low Limit	F	Time

11.11 Supervisions

11.11.1 (ID 1431) Supervision #1 Item Selection

Location in the menu: **P3.8.1**

Use this parameter to select the supervision item. The output of the supervision function can be selected to the relay output.

11.11.2 (ID 1432) Supervision #1 Mode

Location in the menu: **P3.8.2**

Use this parameter to set the supervision mode.

When the 'Low limit' mode is selected, the output of the supervision function is active when the signal is below the supervision limit.

When the 'High limit' mode is selected, the output of the supervision function is active when the signal is above the supervision limit.

11.11.3 (ID 1433) Supervision #1 Limit

Location in the menu: **P3.8.3**

Use this parameter to set the supervision limit for the selected item. The unit shows automatically.

11.11.4 (ID 1434) Supervision #1 Limit Hysteresis

Location in the menu: **P3.8.4**

Use this parameter to set the supervision limit hysteresis for the selected item. The unit shows automatically.

11.11.5 (ID 1435) Supervision #2 Item Selection

Location in the menu: **P3.8.5**

Use this parameter to select the supervision item. The output of the supervision function can be selected to the relay output.

11.11.6 (ID 1436) Supervision #2 Mode

Location in the menu: **P3.8.6**

Use this parameter to set the supervision mode.

11.11.7 (ID 1437) Supervision #2 Limit

Location in the menu: **P3.8.7**

Use this parameter to set the supervision limit for the selected item. The unit shows automatically.

11.11.8 (ID 1438) Supervision #2 Limit Hysteresis

Location in the menu: **P3.8.8**

Use this parameter to set the supervision limit hysteresis for the selected item. The unit shows automatically.

11.12 Protections

11.12.1 General

11.12.1.1 (ID 701) Response to External Fault

Location in the menu: **P3.9.1.2**

Use this parameter to select the response of the drive to an 'External Fault'.

If a fault occurs, the drive can show a notification of it on the display of the drive. An external fault is activated with a digital input signal. The default digital input is DI3. It is also possible to program the response data into a relay output.

11.12.1.2 (ID 730) Input Phase Fault

Location in the menu: **P3.9.1.3**

Use this parameter to select the supply phase configuration of the drive.

If the 1-phase supply is used, the value of this parameter must be set to 1-phase support.

11.12.1.3 (ID 727) Undervoltage Fault

Location in the menu: **P3.9.1.4**

Use this parameter to select if undervoltage faults are saved to the fault history or not.

11.12.1.4 (ID 702) Response to Output Phase Fault

Location in the menu: **P3.9.1.5**

Use this parameter to select the response of the drive to an 'Output Phase' fault. If the measurement of the motor current detects that there is no current in 1 motor phase, an output phase fault occurs. See P3.9.1.2.

11.12.1.5 (ID 733) Response to Fieldbus Communication Fault

Location in the menu: **P3.9.1.6**

Use this parameter to select the response of the drive to a fieldbus communication fault. If the data connection between the master and the fieldbus board is defective, a fieldbus fault occurs.

11.12.1.6 (ID 734) Slot Communication Fault

Location in the menu: **P3.9.1.7**

Use this parameter to select the response of the drive to a 'Slot Communication' fault. If the drive detects a defective option board, a slot communication fault occurs. See P3.9.1.2.

11.12.1.7 (ID 732) Thermistor Fault

Location in the menu: **P3.9.1.8**

Use this parameter to select the response of the drive to a 'Thermistor' fault. If the thermistor detects too high temperature, a thermistor fault occurs. See P3.9.1.2.

11.12.1.8 (ID 748) PID Soft Fill Fault

Location in the menu: **P3.9.1.9**

Use this parameter to select the response of the drive to a 'PID Soft Fill' fault. If the PIDFeedback value does not reach the set level within the time limit, a soft fill fault occurs. See P3.9.1.2.

11.12.1.9 (ID 749) Response to PID Supervision Fault

Location in the menu: **P3.9.1.10**

Use this parameter to select the response of the drive to a 'PID Supervision' fault. If the PID feedback value is not within the supervision limits for longer than the supervision delay, a PID supervision fault occurs. See P3.9.1.2.

11.12.1.10 (ID 757) Response to External PID Supervision Fault

Location in the menu: **P3.9.1.11**

Use this parameter to select the response of the drive to a 'PID Supervision' fault. If the PID feedback value is not within the supervision limits for longer than the supervision delay, a PID supervision fault occurs. See P3.9.1.2.

11.12.1.11 (ID 703) Earth Fault

Location in the menu: **P3.9.1.12**

Use this parameter to select the response of the drive to an 'Earth Fault'.

If the measurement of the current detects that the sum of the motor phase currents is not 0, an earth fault occurs. See P3.9.1.2.

NOTICE

It is possible to configure this fault only in enclosure sizes MR7, MR8, MR9, MR10, MR11, and MR12, and also MR6 600 V & 690 V.

11.12.1.12 (ID 183) Preset Alarm Frequency

Location in the menu: **P3.9.1.13**

Use this parameter to set the frequency of the drive when a fault is active and the response to the fault is set to 'Alarm + Preset Frequency'.

11.12.1.13 (ID 775) Response to Safe Torque Off (STO) Fault

Location in the menu: **P3.9.1.14**

Use this parameter to select the response of the drive to a 'STO Fault'.

This parameter defines drive operation when Safe Torque Off (STO) function is activated (for example, emergency stop button has been pressed or some other STO operation has been activated). See P3.9.1.2.

11.12.1.14 (ID 15593) Startup Prevented Fault

Location in the menu: **P3.9.1.15**

Use this parameter to select the response of the AC drive to a "Startup prevented" fault.

11.12.1.15 (ID 750) Response to Fieldbus Redundant Control Switchover

Location in the menu: **P3.9.1.16**

Use this parameter to select the response of the AC drive to a "Fieldbus redundant control switchover" indication.

11.12.1.16 (ID 751) Fieldbus Communication Fault Force Delay

Location in the menu: **P3.9.1.17**

Use this parameter to set a delay for temporarily forcing the fault response for a fieldbus communication fault from "No Action", "Alarm", or "Alarm + Preset Fault Frequency" to fault. When a timeout occurs, the drive responds as selected with P3.9.1.6 ([11.12.1.5 \(ID 733\) Response to Fieldbus Communication Fault](#)) and keeps running. After the delay time set by this parameter, the drive goes to a fault state and stops running.

If this parameter is set to 0.00 s, the fault response stays as it is set with P3.9.1.6 and the drive runs indefinitely. If the fault response is "Fault (Stop according to stop function)" or "Fault (Stop by coasting)", this delay has no effect.

11.12.1.17 (ID 752) Fieldbus Communication Fault Clear Delay

Location in the menu: **P3.9.1.18**

Use this parameter to set a delay for accepting new fieldbus start commands, fieldbus reverse commands, and fieldbus reference commands after a fieldbus communication fault has been cleared. The delay does not start after clearing a fieldbus communication fault, but after the connection has been re-established.

11.12.1.18 (ID 753) Unbalance Current Alarm

Location in the menu: **P3.9.1.19**

Use this parameter to set the response of the drive to an unbalance current alarm. The available values are "No action" and "Alarm".

This parameter is only available for the enclosure sizes MR11 and MR12.

11.12.2 Motor Thermal Protections

The motor thermal protection prevents the motor from becoming too hot.

The AC drive can supply a current that is higher than the nominal current. The high current can be necessary to the load, and it must be used. In these conditions, there is a risk of a thermal overload. Low frequencies have a higher risk. At low frequencies, the cooling effect and the capacity of the motor decrease. If the motor has an external fan, the load reduction at low frequencies is small.

The motor thermal protection is based on calculations. The protection function uses the output current of the drive to know what is the load on the motor. If the control board is not energized, the calculations are reset.

To adjust the thermal protection of the motor, use the parameters from P3.9.2.1 to P3.9.2.5. It is possible to monitor the thermal status of the motor on the display of the control panel.

NOTICE

If long motor cables (maximum 100 m) are used with small drives (≤ 1.5 kW), the motor current that the drive measures can be much higher than the actual motor current. It is because there are capacitive currents in the motor cable.

NOTICE

OVERHEATING BECAUSE OF BLOCKED AIRFLOW

If the airflow to the motor is blocked, the function does not protect the motor, and the motor can become too hot. It can damage the motor.

- Make sure that the airflow to the motor is not blocked.

11.12.2.1 (ID 704) Motor Thermal Protection

Location in the menu: **P3.9.2.1**

Use this parameter to select the response of the drive to a 'Motor Overtemperature' fault. If the motor thermal protection function detects that the temperature of the motor is too high, a motor overtemperature fault occurs.

If possible, use a motor thermistor to protect the motor. Set the value of this parameter to 0.

11.12.2.2 (ID 705) Ambient Temperature

Location in the menu: **P3.9.2.2**

Use this parameter to set the ambient temperature where the motor is installed. The temperature value is given in Celsius or Fahrenheit degrees.

11.12.2.3 (ID 706) Zero Speed Cooling Factor

Location in the menu: **P3.9.2.3**

Use this parameter to set the cooling factor at 0 speed in relation to the point where the motor operates at nominal speed without external cooling.

The default value is set for conditions where there is no external fan. When using an external fan, the value can be set higher than without the fan, for example at 90%.

When changing parameter P3.1.1.4 (Motor Nominal Current), parameter P3.9.2.3 is automatically set to its default value.

The corner frequency for the thermal protection is 70% of the value of the parameter P3.1.1.2 Motor Nominal Frequency.

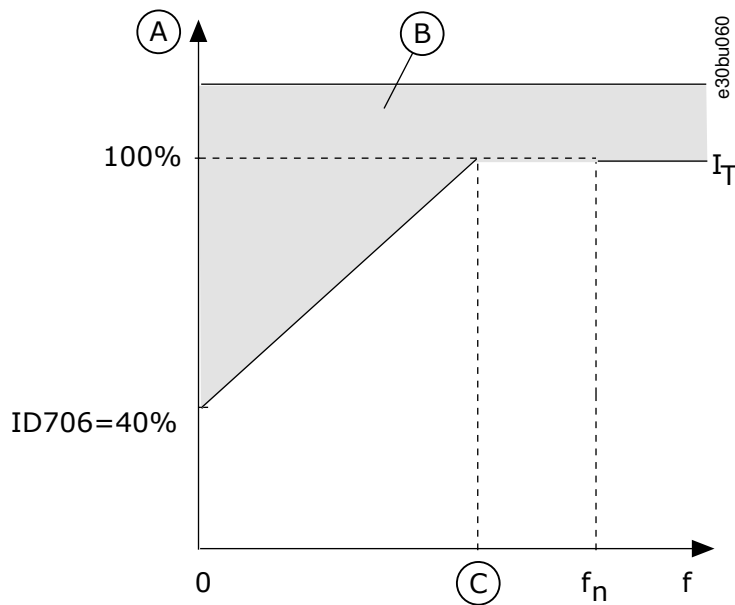

Illustration 54: The Motor Thermal Current I_T Curve

A	$P_{Cooling}$	C	Corner frequency
B	Overload area		

11.12.2.4 (ID 707) Motor Thermal Time Constant

Location in the menu: **P3.9.2.4**

Use this parameter to set the motor thermal time constant.

The time constant is the time within which the calculated thermal stage has reached 63% of its final value. The final thermal stage equals to running the motor continuously with nominal load at nominal speed. The length of the time constant is in relation with the dimension of the motor. The bigger the motor, the longer the time constant.

In different motors, the motor thermal time constant is different. It also changes between different motor manufacturers. The default value of the parameter changes from dimension to dimension.

The t_6 -time is the time in seconds that the motor can safely operate at 6 times the rated current. It is possible that the motor manufacturer gives the data with the motor. Use this information to set the time constant parameter. Usually, the motor thermal time constant in minutes is $2 \cdot t_6$. When the drive is in the *STOP* state, the time constant is internally increased to 3 times the set parameter value, because the cooling operates based on convection.

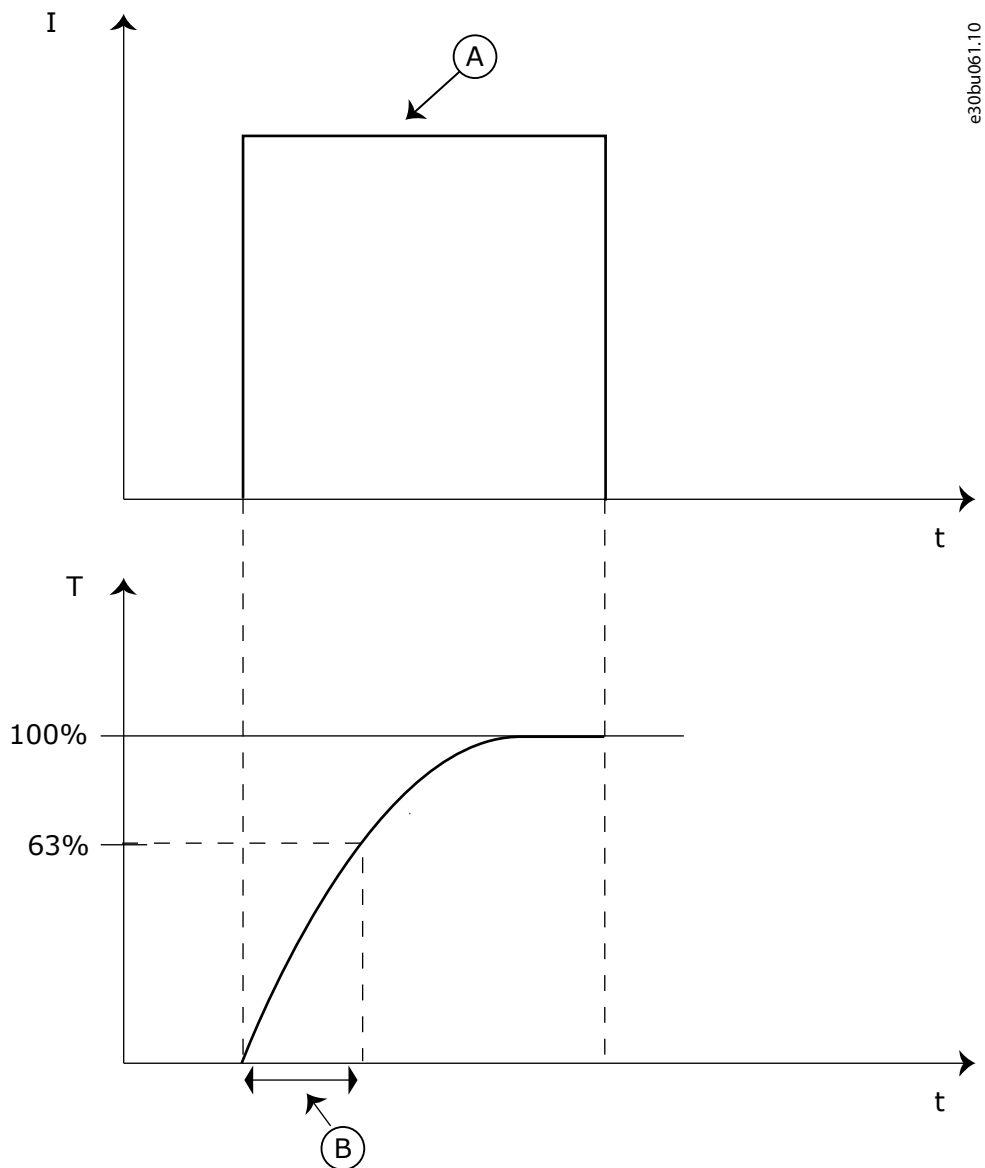

e30bu061.10

Illustration 55: The Motor Thermal Time Constant

- | | |
|---|-----------------------------|
| A | Current |
| B | Motor thermal time constant |

11.12.2.5 (ID 708) Motor Thermal Loadability

Location in the menu: P3.9.2.5

Use this parameter to set the thermal loadability of the motor. For example, if the value is set to 130%, the motor goes to the nominal temperature with 130% of the motor nominal current.

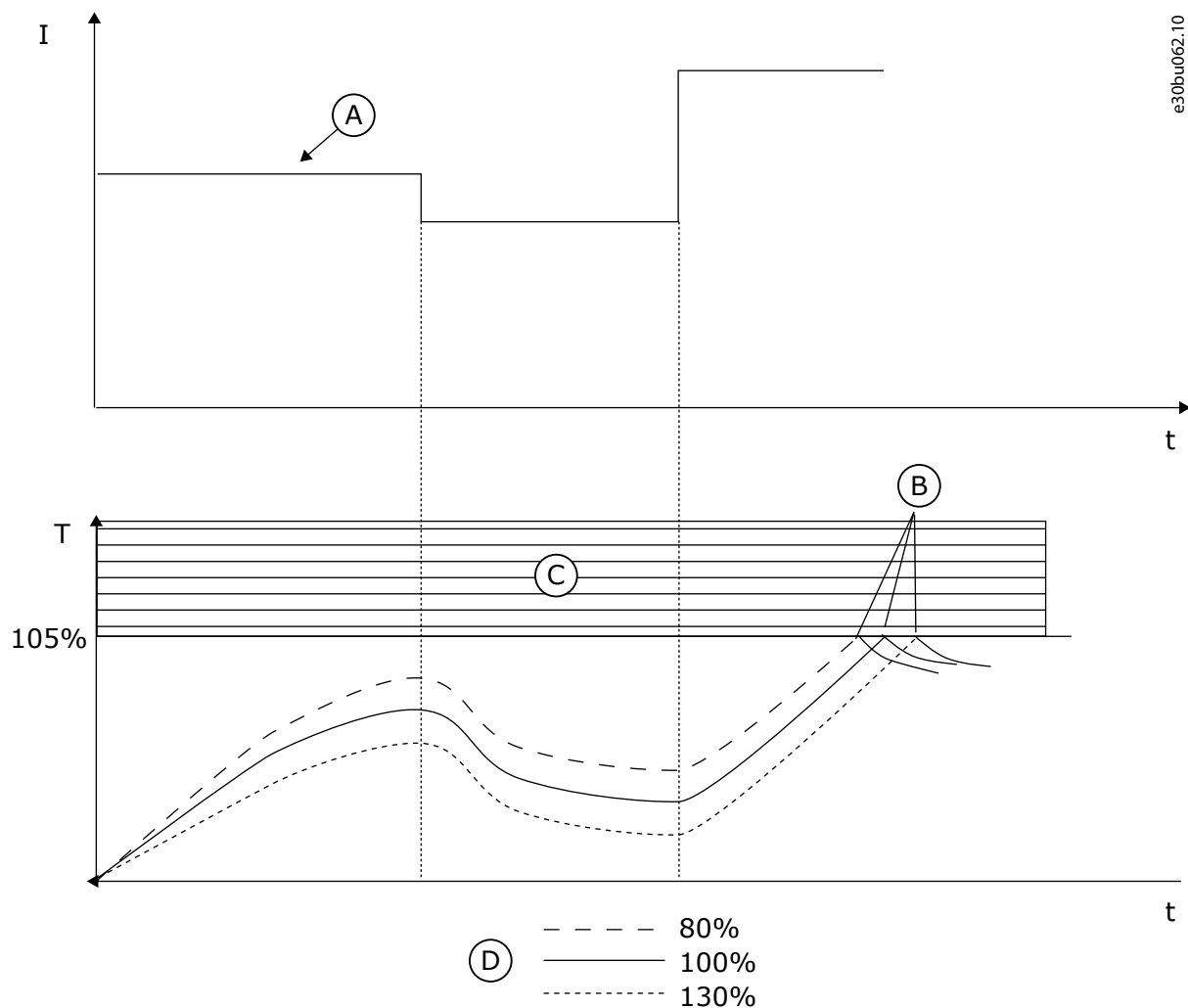

e30bu062.10

Illustration 56: The Calculation of the Motor Temperature

A	Current	C	Trip area
B	Fault/Alarm	D	Loadability

11.12.2.6 (ID 778) Motor Thermal Memory Adjust

Location in the menu: **P3.9.2.6**

Use this parameter to set the motor thermal memory adjust value.

11.12.3 Motor Stall Protection

The motor stall protection function gives protection to the motor against short overloads. An overload can be caused, for example, by a stalled shaft. It is possible to set the reaction time of the stall protection shorter than that of the motor thermal protection.

The stall status of the motor is specified with parameters P3.9.3.2 Stall Current and P3.9.3.4 Stall Frequency Limit. If the current is higher than the limit, and the output frequency is lower than the limit, the motor is in a stall status.

The stall protection is a type of overcurrent protection.

NOTICE

If long motor cables (maximum 100 m) are used with small drives (≤ 1.5 kW), the motor current that the drive measures can be much higher than the actual motor current. It is because there are capacitive currents in the motor cable.

11.12.3.1 (ID 709) Motor Stall Fault

Location in the menu: **P3.9.3.1**

Use this parameter to select the response of the drive to a 'Motor Stall' fault. If the stall protection detects that the shaft of the motor is stalled, a motor stall fault occurs.

11.12.3.2 (ID 710) Stall Current

Location in the menu: **P3.9.3.2**

Use this parameter to set the limit above which the current of the motor must stay for a stall stage to occur.

It is possible to set the value of this parameter between 0.0 and $2 \cdot I_L$. For a stall status to occur, the current must be higher than this limit. If parameter P3.1.3.1 Motor Current Limit changes, this parameter is automatically calculated to 90% of the current limit.

The value of the Stall Current must be below the motor current limit.

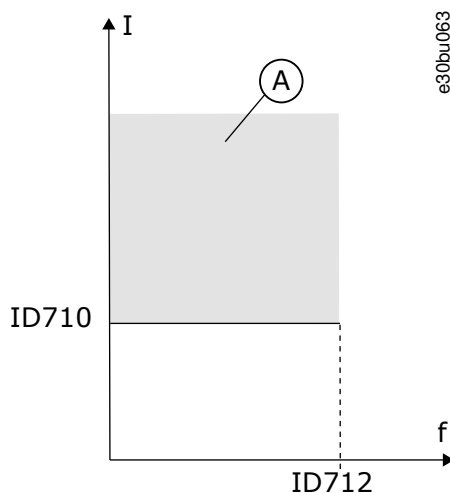

Illustration 57: The Stall Characteristics Settings

A	Stall area
---	------------

11.12.3.3 (ID 711) Stall Time Limit

Location in the menu: **P3.9.3.3**

Use this parameter to set the maximum time for a stall stage.

This parameter is the maximum time for the stall stage to be active before a motor stall fault occurs. The value of this parameter can be set between 1.0 s and 120.0 s. An internal counter counts the stall time. If the stall time counter value goes above this limit, the protection causes the drive to trip.

11.12.3.4 (ID 712) Stall Frequency Limit

Location in the menu: **P3.9.3.4**

Use this parameter to set the limit below which the output frequency of the drive must stay for a stall stage to occur.

For a stall state to occur, the output frequency must be below this limit for a certain time.

11.12.4 Underload Protection

The motor underload protection makes sure that there is a load on the motor when the drive operates. If the motor loses the load, a problem can occur in the process. For example, a belt can break or a pump become dry.

The motor underload protection can be adjusted with parameters P3.9.4.2 (Underload Protection: Field Weakening Area Load) and P3.9.4.3 (Underload Protection: Zero Frequency Load). The underload curve is a squared curve between the zero frequency and the field weakening point. The protection is not active below 5 Hz. The underload time counter does not operate below 5 Hz.

The values of the underload protection parameters are set in percentage of the nominal torque of the motor. To find the scaling ratio for the internal torque value, use the data in the nameplate data of the motor, the motor nominal current, and the nominal current of the drive I_H . If another current than the nominal motor current is used, the precision of the calculation decreases.

NOTICE

If long motor cables (maximum 100 m) are used with small drives (≤ 1.5 kW), the motor current that the drive measures can be much higher than the actual motor current. It is because there are capacitive currents in the motor cable.

11.12.4.1 (ID 713) Underload Fault

Location in the menu: **P3.9.4.1**

Use this parameter to select the response of the drive to an 'Underload' fault. If the underload protection function detects that there is not a sufficient load on the motor, an underload fault occurs.

11.12.4.2 (ID 714) Underload Protection: Field Weakening Area Load

Location in the menu: **P3.9.4.2**

Use this parameter to set the minimum torque that the motor needs when the output frequency of the drive is higher than the frequency of the weakening point. It is possible to set the value of this parameter between 10.0% and 150.0% $\times T_{nMotor}$. This value is the limit for the minimum torque when the output frequency is above the field weakening point.

Changing parameter P3.1.1.4 (Motor Nominal Current) restores this parameter automatically to its default value. See [11.12.4 Underload Protection](#).

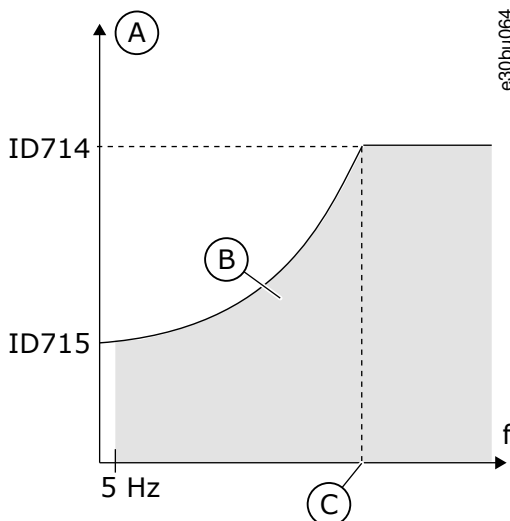

Illustration 58: Setting of the Minimum Load

A	Torque	C	Field weakening point
B	Underload area		

11.12.4.3 (ID 715) Underload Protection: Zero Frequency Load

Location in the menu: **P3.9.4.3**

Use this parameter to set the minimum torque that the motor needs when the output frequency of the drive is 0.

Changing the value of parameter P3.1.1.4 restores this parameter automatically to the default value.

11.12.4.4 (ID 716) Underload Protection: Time Limit

Location in the menu: **P3.9.4.4**

Use this parameter to set the maximum time for an underload state. It is the maximum time for the underload state to be active before an underload fault occurs.

It is possible to set the time limit between 2.0 s and 600.0 s.

An internal counter counts the underload time. If the value of the counter goes above this limit, the protection causes the drive to trip. The drive trips as is set in parameter P3.9.4.1 Underload Fault. If the drive stops, the underload counter goes back to 0.

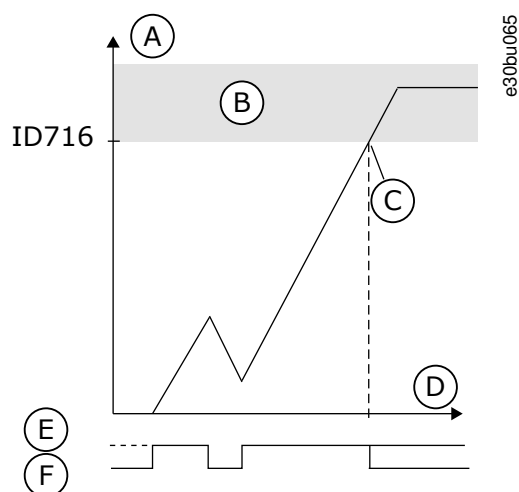

Illustration 59: The Underload Time Counter Function

A	Underload time counter	D	Time
B	Trip area	E	Underload
C	Trip/warning ID 713	F	No underload

11.12.5 Quick Stop

11.12.5.1 (ID 1276) Quick Stop Mode

Location in the menu: P3.9.5.1

Use this parameter to select how the drive stops when the quick stop command is given from DI or Fieldbus.

11.12.5.2 (ID 1213) Quick Stop Activation

Location in the menu: P3.9.5.2

Use this parameter to select the digital input signal that activates a Quick Stop function. The Quick Stop function stops the drive regardless of the control place or the state of the control signals.

11.12.5.3 (ID 1256) Quick Stop Deceleration Time

Location in the menu: P3.9.5.3

Use this parameter to set the time that is necessary for the output frequency to decrease from maximum frequency to 0 when a quick stop command is given. The value of this parameter is applied only when the quick stop mode parameter is set to 'Quick Stop Deceleration time'.

11.12.5.4 (ID 744) Response to Quick Stop Fault

Location in the menu: P3.9.5.4

Use this parameter to select the response of the drive to a 'Quick Stop' fault. If the quick stop command is given from DI or Fieldbus, a quick stop fault occurs.

With the quick stop function, it is possible stop the drive in an unusual procedure from I/O or Fieldbus in unusual conditions. When the quick stop function is active, it is possible make the drive decelerate and stop. It is possible to program an alarm or fault to put a mark in the fault history that there was a request for a quick stop.

⚠ CAUTION ⚠

Do not use the quick stop function as an emergency stop. An emergency stop must stop the power supply to the motor. The quick stop function does not do this.

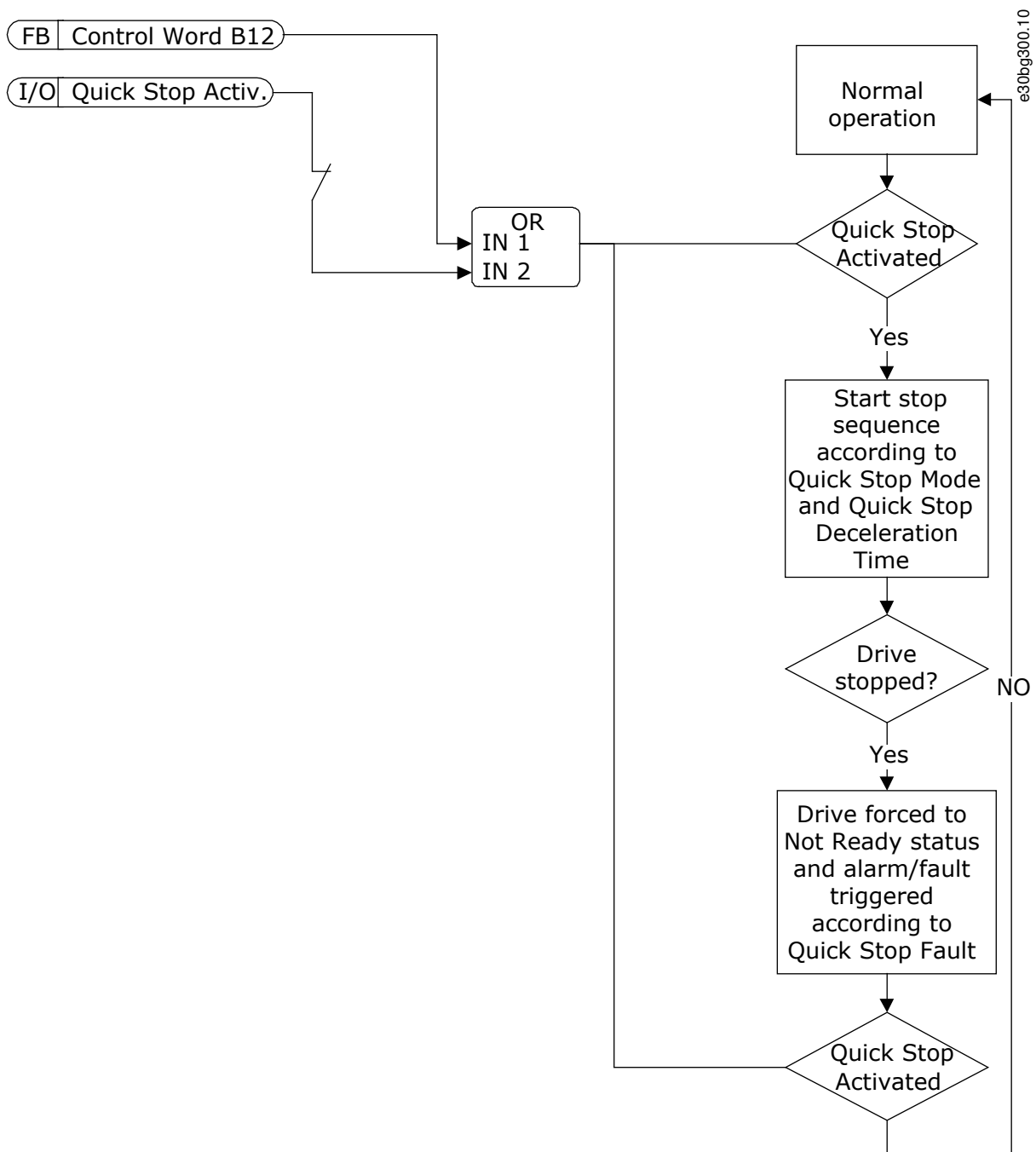

Illustration 60: The Quick Stop Logic

11.12.6 Temperature Input Fault

11.12.6.1 (ID 739) Temperature Signal 1

Location in the menu: **P3.9.6.1**

Use this parameter to select the temperature input signals that are supervised.

The maximum value is taken from the set signals and used for alarm and fault triggering.

NOTICE

Only the 6 first temperature inputs are supported (the boards from slot A to slot E).

11.12.6.2 (ID 741) Alarm Limit 1

Location in the menu: **P3.9.6.2**

Use this parameter to set the temperature alarm limit.

Only the inputs that are set with parameter P3.9.6.1 are compared.

11.12.6.3 (ID 742) Fault Limit 1

Location in the menu: **P3.9.6.3**

Use this parameter to set the temperature fault limit.

Only the inputs that are set with parameter P3.9.6.1 are compared.

11.12.6.4 (ID 740) Fault Limit Response 1

Location in the menu: **P3.9.6.4**

Use this parameter to select the response of the drive to 'Temperature' fault.

11.12.6.5 (ID 763) Temperature Signal 2

Location in the menu: **P3.9.6.5**

Use this parameter to select the temperature input signals that are supervised.

The maximum value is taken from the set signals and used for alarm and fault triggering.

NOTICE

Only the 6 first temperature inputs are supported (the boards from slot A to slot E).

11.12.6.6 (ID 764) Alarm Limit 2

Location in the menu: **P3.9.6.6**

Use this parameter to set the temperature alarm limit.

Only the inputs that are set with parameter P3.9.6.5 are compared.

11.12.6.7 (ID 765) Fault Limit 2

Location in the menu: **P3.9.6.7**

Use this parameter to set the temperature fault limit.

Only the inputs that are set with parameter P3.9.6.5 are compared.

11.12.6.8 (ID 766) Fault Limit Response 2

Location in the menu: **P3.9.6.8**

Use this parameter to select the response of the drive to 'Temperature' fault.

NOTICE

Temperature input settings are only available if an OPTB8 or OPTBH option board is installed.

11.12.7 AI Low Protection

11.12.7.1 (ID 767) Analog Input Low Protection

Location in the menu: **P3.9.8.1**

Use this parameter to select when the AI Low supervision is enabled. For example, the AI Low supervision can be enabled only when the drive is in run state.

Use the AI Low Protection to find failures in the analog input signals. This function gives protection only to the analog inputs that are used as frequency reference, torque reference, or in the PID/ExtPID controllers.

It is possible to have the protection on when the drive is in the RUN status, or in the RUN and STOP statuses.

Selection number	Selection name	Description
0	Protection disabled	
1	Protection enabled in RUN status	The protection is enabled only when the drive is in the RUN status.
2	Protection enabled in RUN and STOP status	The protection is enabled in the 2 statuses, RUN, and STOP.

11.12.7.2 (ID 700) Analog Input Low Fault

Location in the menu: **P3.9.8.2**

Use this parameter to select the response of the drive to an 'AI Low' fault. If the analog input signal becomes less than 50% of the minimum signal for 500 ms, an AI Low fault occurs.

If AI Low Protection is enabled with parameter P3.9.8.1, this parameter gives a response for the fault code 50 (Fault ID 1050).

The AI low protection function monitors the signal level of the analog inputs 1–6. If the analog input signal becomes less than 50% of the minimum signal for 500 ms, an AI Low fault, or alarm shows.

N O T I C E

It is possible to use the value Alarm + previous frequency only when using analog input 1 or analog input 2 as frequency reference.

Selection number	Selection name	Description
0	No Action	AI Low Protection is not used.
1	Alarm	
2	Alarm, preset frequency	The frequency reference is set as in P3.9.1.13 Preset Alarm Frequency.
3	Alarm, previous frequency	The last valid frequency is kept as frequency reference.
4	Fault	The drive stops as is set in P3.2.5 Stop Mode.
5	Fault, coasting	The drive stops by coasting.

11.12.8 User Defined Fault 1

11.12.8.1 (ID 15523) User Defined Fault 1

- Location in the menu: **P3.5.1.50** (In I/O Configuration parameter menu)
- Location in the menu: **P3.9.9.1** (In Protections parameter menu)

Use this parameter to set the digital input signal that activates User Defined Fault 1 (Fault ID 1114).

11.12.8.2 (ID 15525) Response to User Defined Fault 1

Location in the menu: **P3.9.9.2**

Use this parameter to select the response of the drive to User Defined Fault 1 (Fault ID 1114).

11.12.9 User Defined Fault 2

11.12.9.1 (ID 15524) User Defined Fault 2

- Location in the menu: **P3.5.1.51** (In I/O Configuration parameter menu)
- Location in the menu: **P3.9.10.1** (In Protections parameter menu)

Use this parameter to set the digital input signal that activates User Defined Fault 2 (Fault ID 1115).

11.12.9.2 (ID 15526) Response to User Defined Fault 2

Location in the menu: **P3.9.10.2**

Use this parameter to select the response of the drive to User Defined Fault 2 (Fault ID 1115).

11.13 Automatic Reset

11.13.1 (ID 731) Automatic Reset

Location in the menu: **P3.10.1**

Use this parameter to enable the Automatic reset function. To select the faults that are reset automatically, enter the value 0 or 1 to parameters from P3.10.6 to P3.10.13.

NOTICE

The automatic reset function is available only for some fault types.

11.13.2 (ID 719) Restart Function

Location in the menu: **P3.10.2**

Use this parameter to select the start mode for the Automatic reset function.

11.13.3 (ID 717) Wait Time

Location in the menu: **P3.10.3**

Use this parameter to set the wait time before the first reset is done.

11.13.4 (ID 718) Trial Time

Location in the menu: **P3.10.4**

Use this parameter to set the trial time for the automatic reset function. During the trial time, the automatic reset function tries to reset the faults that occur.

The time count starts from the first automatic reset. The next fault starts the trial time count again.

11.13.5 (ID 759) Number of Trials

Location in the menu: **P3.10.5**

Use this parameter to set the total number of auto reset trials. If the number of trials during the trial time is more than the value of this parameter, a permanent fault shows. If not, the fault goes out of view after the trial time is completed. The fault type does not affect the maximum number of trials.

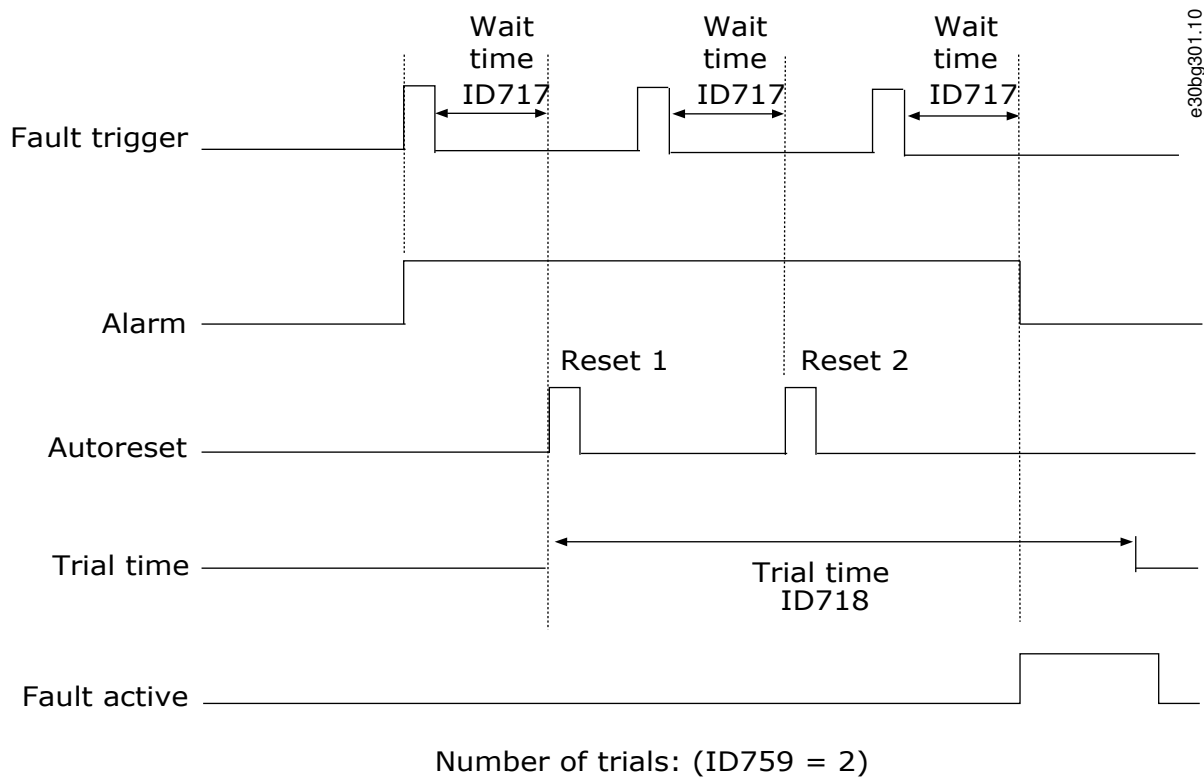

e30bg301.10

Illustration 61: The Automatic Reset Function

11.13.6 (ID 720) Autoreset: Undervoltage

Location in the menu: **P3.10.6**

Use this parameter to enable the automatic reset after an undervoltage fault.

11.13.7 (ID 721) Autoreset: Overvoltage

Location in the menu: **P3.10.7**

Use this parameter to enable the automatic reset after an overvoltage fault.

11.13.8 (ID 722) Autoreset: Overcurrent

Location in the menu: **P3.10.8**

Use this parameter to enable the automatic reset after an overcurrent fault.

11.13.9 (ID 723) Autoreset: AI Low

Location in the menu: **P3.10.9**

Use this parameter to enable the automatic reset after a fault caused by low AI signal.

11.13.10 (ID 724) Autoreset: Unit Overtemperature

Location in the menu: **P3.10.10**

Use this parameter to enable the automatic reset after a fault caused by unit overtemperature.

11.13.11 (ID 725) Autoreset: Motor Overtemperature

Location in the menu: **P3.10.11**

Use this parameter to enable the automatic reset after a fault caused by motor overtemperature.

11.13.12 (ID 726) Autoreset: External Fault

Location in the menu: **P3.10.12**

Use this parameter to enable the automatic reset after an external fault.

11.13.13 (ID 738) Autoreset: Underload Fault

Location in the menu: **P3.10.13**

Use this parameter to enable the automatic reset after an underload fault.

11.13.14 (ID 776) Autoreset: PID Supervision Fault

Location in the menu: **P3.10.14**

Use this parameter to enable the automatic reset after a PID supervision fault.

11.13.15 (ID 777) Autoreset: EXT PID Supervision Fault

Location in the menu: **P3.10.15**

Use this parameter to enable the automatic reset after an external PID supervision fault.

11.13.16 (ID 1569) Fault Simulation

Location in the menu: **P3.10.16**

With this parameter it is possible to simulate the different faults without them being actually active. For example simulating an over current situation. In the drive interface point of view the behavior is identical to actual fault situations.

Selection	Name	Description
B00	1 ₁₀	Over current fault (F1)
B01	2 ₁₀	Over voltage fault (F2)
B02	4 ₁₀	Under voltage fault (F9)
B03	8 ₁₀	Output phase supervision fault (F11)
B04	16 ₁₀	Earth voltage fault (F3)
B05	32 ₁₀	System fault (F8)
B06	64 ₁₀	Over temperature warning (W14)
B07	128 ₁₀	Over temperature fault (F14) ⁽¹⁾
B08	256 ₁₀	Reserved
B09	512 ₁₀	Reserved
B10	1024 ₁₀	Fan cooling fault (F32)

¹ The warning bit needs to be high also for this fault simulation to work.

11.14 Application Settings

11.14.1 (ID 1806) Password

Location in the menu: **P3.11.1**

Use this parameter to set the administrator password.

11.14.2 (ID 1197) C/F Selection

Location in the menu: **P3.11.2**

Use this parameter to set the temperature measuring unit. The system shows all the temperature-related parameters and monitoring values in the set unit.

11.14.3 (ID 1198) kW/HP Selection

Location in the menu: **P3.11.3**

Use this parameter to set the power measuring unit. The system shows all the power-related parameters and monitoring values in the set unit.

11.14.4 (ID 1196) Multimonitor View

Location in the menu: **P3.11.4**

Use this parameter to set the division of the display of the control panel into sections in the multimonitor view.

11.14.5 (ID 1195) [FUNCT] Button Configuration

Location in the menu: **P3.11.5**

Use this parameter to set the values of the [FUNCT] button. The values set with this parameter are available when pushing the [FUNCT] button on the keypad.

11.14.6 (ID 1807) Set Parameter Lock

Location in the menu: **P3.11.6**

Use this parameter to set a password for edit-locking all parameters. Parameters are locked if value is set greater than zero. To disable the lock, open the lock with a correct key, and set the lock-password back to zero.

NOTE! After setting this parameter to larger than zero (0), the lock is immediately active. Setting a lock also locks and hide this parameter itself. Control place cannot be changed over to Local, when the lock is in place.

11.14.7 (ID 1808) Parameter Lock Key

Location in the menu: **P3.11.7**

Use this parameter to enter a password for opening the parameter edit-lock. The lock is opened if the values of the Key- and Lock-passwords are equal.

11.15 Timer Functions

11.15.1 Introduction to Timer Functions

The timer functions make it possible for the internal RTC (real-time clock) to control functions. All the functions that can be controlled with a digital input, can also be controlled with the RTC, with time channels 1–3. It is not necessary to have an external PLC to control a digital input. It is possible program the closed and opened intervals of the input internally.

To get the best results of the timer functions, install a battery, and make the settings of the real-time clock carefully in the Start-up wizard. The battery is available as an option.

N O T I C E

It is not recommended to use the timer functions without an auxiliary battery. The time and date settings of the drive are reset at each power down, if there is no battery for the RTC.

11.15.2 Time Channels, Intervals, and Timers

Time Channels

It is possible to assign the output of the interval and/or timer functions to time channels 1–3. It is possible to use the time channels to control on/off type functions, for example relay outputs or digital inputs. To configure the on/off logic of the time channels, assign intervals and/or timers to them. A time channel can be controlled by many different intervals or timers.

Assigning intervals and timers to time channels is flexible. Every interval and timer has a parameter with which to assign them to a time channel.

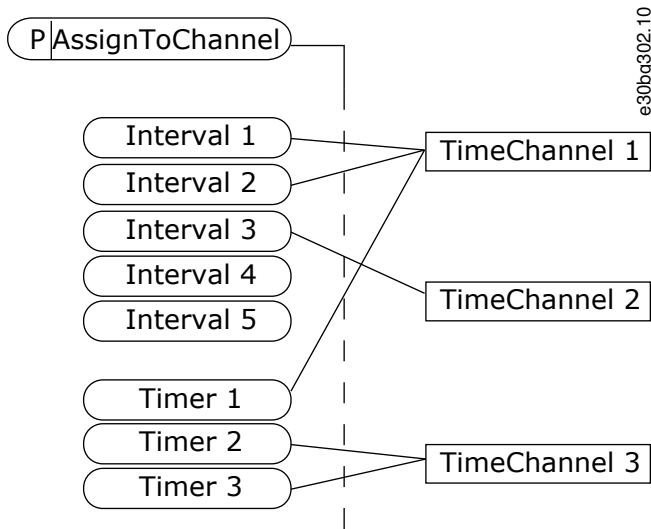

Illustration 62: Assigning Intervals and Timers to time Channels

Intervals

Use parameters to give each interval an ON Time and OFF Time. It is the daily active time of the interval during the days set with parameters From Day and To Day. For example, with the parameter settings below, the interval is active from 7 am to 9 am from Monday to Friday. The time channel is like a digital input, but virtual.

- ON Time: 07:00:00
- OFF Time: 09:00:00
- From Day: Monday
- To Day: Friday

Timers

Use the timers to set a time channel as active for a period with a command from a digital input or a time channel.

In the following figure, the activation signal comes from a digital input or a virtual digital input, like a time channel. The timer counts down from the falling edge.

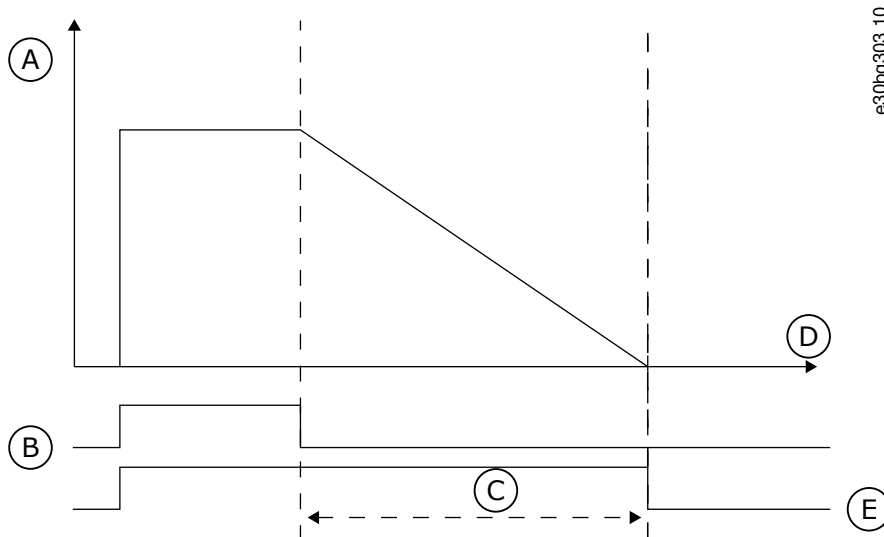

Illustration 63: The Activation Signal from Digital Input or Virtual Digital Input

A	Remaining time	D	Time
B	Activation	E	OUT
C	Duration		

The following parameters set the timer active when the digital input 1 on the slot A is closed. They will also keep the timer active for 30 s after it is opened.

- Duration: 30 s
- Timer: DigIn SlotA.1

It is possible use a duration of 0 s to override a time channel that is activated from a digital input. There is no off delay after the falling edge.

Example

Problem: The AC drive is in a warehouse and controls air conditioning. It must operate between 7 am and 5 pm on weekdays and between 9 am and 1 pm on weekends. It is also necessary for the drive to operate outside these hours, if there are personnel in the building. The drive must continue to operate 30 minutes after the personnel has left.

Solution: Set 2 intervals, 1 for weekdays and 1 for weekends. A timer is also necessary to activate the process outside the set hours. See the following configuration.

Interval 1

- P3.12.1.1: ON Time: 07:00:00
- P3.12.1.2: OFF Time: 17:00:00
- P3.12.1.3: Days: Monday, Tuesday, Wednesday, Thursday, Friday
- P3.12.1.4: Assign to channel: Time channel 1

Interval 2

- P3.12.2.1: ON Time: 09:00:00
- P3.12.2.2: OFF Time: 13:00:00
- P3.12.2.3: Days: Saturday, Sunday
- P3.12.2.4: Assign to channel: Time channel 1

Timer 1

- P3.12.6.1: Duration: 1800 s (30 min)
- P3.12.6.2: Timer 1: DigIn SlotA.1 (The parameter is in the digital inputs menu.)
- P3.12.6.3: Assign to channel: Time channel 1
- P3.5.1.1: Control signal 1 A: Time Channel 1 for the I/O Run command

In the following figure, Time Channel 1 is used as the control signal for the start command instead of a digital input.

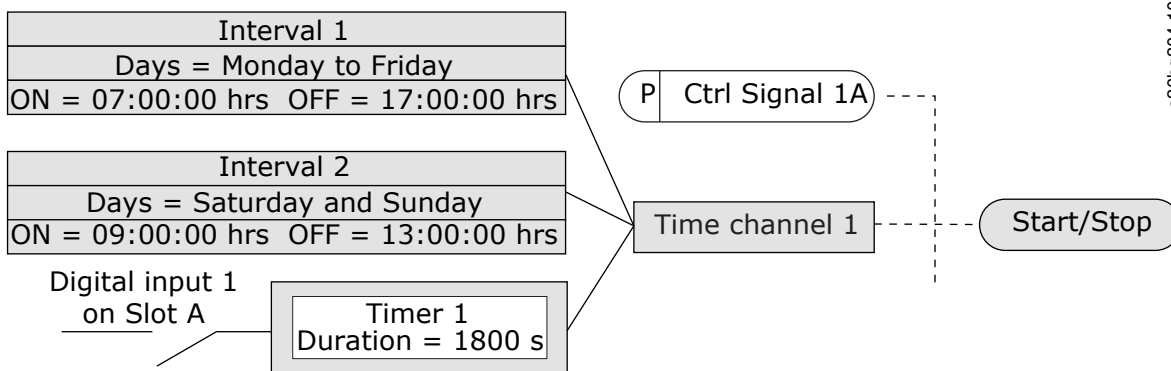

Illustration 64: Time Channel 1 as the Control Signal for the Start Command

11.15.3 Editing an Interval

Procedure

1. Activate the interval to edit.

- Go into parameter Days (ID 1466).

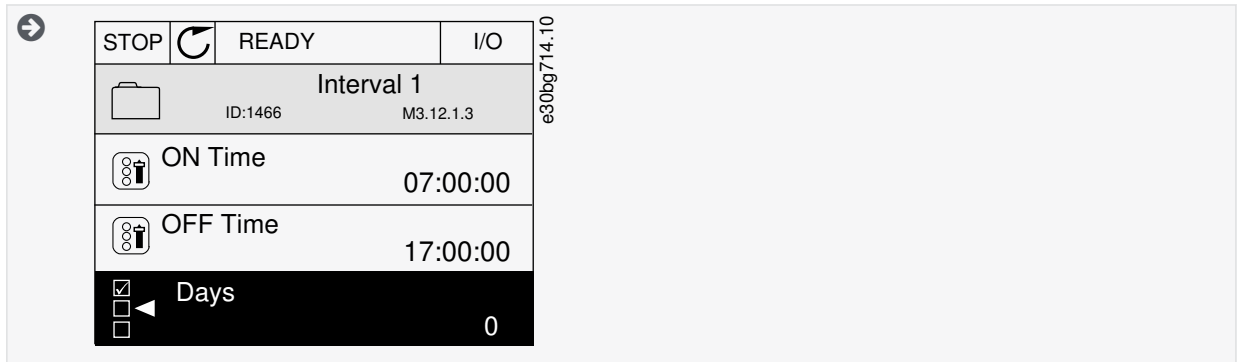

- Go into the Edit mode.
- Select the necessary weekdays in the checkbox selection.

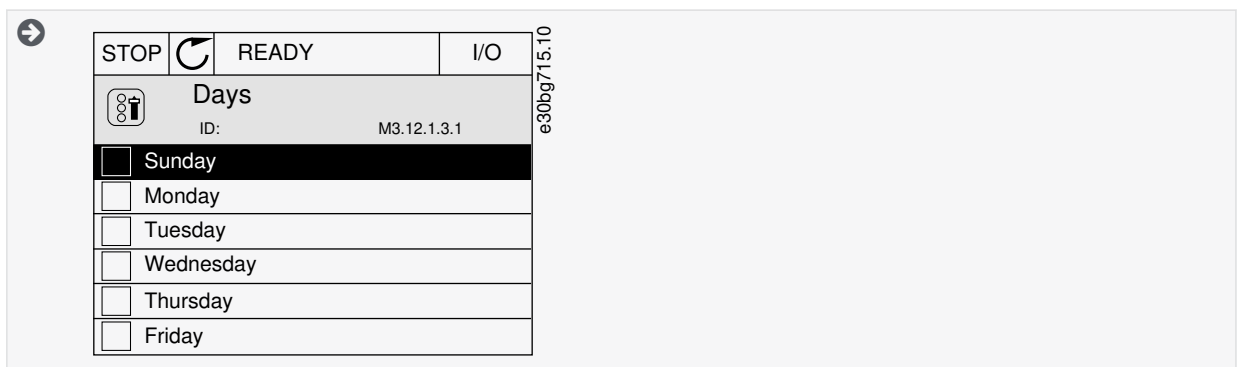

11.15.4 (ID 1464) ON Time

Location in the menu: **P3.12.1.1**

Use this parameter to set the time of day when the output of the interval function is activated.

11.15.5 (ID 1465) OFF Time

Location in the menu: **P3.12.1.2**

Use this parameter to set the time of day when the output of the interval function is deactivated.

11.15.6 (ID 1466) Days

Location in the menu: **P3.12.1.3**

Use this parameter to select the days of the week when the interval function is enabled.

11.15.7 (ID 1468) Assign to Channel

Location in the menu: **P3.12.1.4**

Use this parameter to select the time channel where the output of the interval function is assigned. It is possible to use the time channels to control the on/off type functions, for example relay outputs or any functions that can be controlled by a DI signal.

11.15.8 (ID 1489) Duration

Location in the menu: **P3.12.6.1**

Use this parameter to set the duration that the timer runs when the activation signal is removed (Off-delay).

11.15.9 (ID 447) Timer 1

Location in the menu: **P3.12.6.2**

Use this parameter to select the digital input signal that starts the timer. The output of the timer is activated when this signal is activated. The timer starts to count when this signal is deactivated (falling edge). The output is deactivated when the time that is set with the duration parameter has elapsed. The rising edge starts Timer 1 that is programmed in Group 3.12.

11.15.10 (ID 1490) Assign to Channel

Location in the menu: **P3.12.6.3**

Use this parameter to select the time channel where the output of the timer function is assigned. It is possible to use the time channels to control the on/off type functions, for example relay outputs or any functions that can be controlled by a DI signal.

11.16 PID Controller

11.16.1 Basic Settings

11.16.1.1 (ID 118) PID Gain

Location in the menu: **P3.13.1.1**

Use this parameter to adjust the gain of the PID controller. If this parameter is set to 100%, a change of 10% in the error value causes the controller output to change by 10%.

11.16.1.2 (ID 119) PID Integration Time

Location in the menu: **P3.13.1.2**

Use this parameter to adjust the integration time of the PID controller. If this parameter is set to 1.00 s, a change of 10% in the error value causes the controller output to change by 10.00%/s.

11.16.1.3 (ID 132) PID Derivation Time

Location in the menu: **P3.13.1.3**

Use this parameter to adjust the derivation time of the PID controller. If this parameter is set to 1.00 s, a change of 10% in the error value during 1.00 s causes the controller output to change by 10.00%.

11.16.1.4 (ID 1036) Process Unit Selection

Location in the menu: **P3.13.1.4**

Use this parameter to select the unit for the feedback and the setpoint signals of the PID controller. Select the unit for the actual value.

11.16.1.5 (ID 1033) Process Unit MIN

Location in the menu: **P3.13.1.5**

Use this parameter to set the minimum value of the PID feedback signal. For example, an analog signal of 4...20 mA corresponds to the pressure of 0...10 bar. The value in process units at a 0% feedback or setpoint. This scaling is done for monitoring purposes only. The PID controller still uses the percentage internally for feedbacks and setpoints.

11.16.1.6 (ID 1034) Process Unit MAX

Location in the menu: **P3.13.1.6**

Use this parameter to set the maximum value of the PID feedback signal. For example, an analog signal of 4...20 mA corresponds to the pressure of 0...10 bar. The value in process units at a 0% feedback or setpoint. This scaling is done for monitoring purposes only. The PID controller still uses the percentage internally for feedbacks and setpoints.

11.16.1.7 (ID 1035) Process Unit Decimals

Location in the menu: **P3.13.1.7**

Use this parameter to set the number of decimals for the process unit values. For example, an analog signal of 4...20 mA corresponds to the pressure of 0...10 bar. The value in process units at a 0% feedback or setpoint. This scaling is done for monitoring purposes only. The PID controller still uses the percentage internally for feedbacks and setpoints.

11.16.1.8 (ID 340) Error Inversion

Location in the menu: **P3.13.1.8**

Use this parameter to invert the error value of the PID controller.

11.16.1.9 (ID 1056) Dead Band

Location in the menu: **P3.13.1.9**

Use this parameter to set the dead band area around the PID setpoint value. The value of this parameter is given in the selected process unit. The output of the PID controller is locked if the feedback value stays in the dead band area for the set time.

11.16.1.10 (ID 1057) Dead Band Delay

Location in the menu: **P3.13.1.10**

Use this parameter to set the time that the feedback value must stay in the dead band area before the output of the PID controller is locked. If the actual value stays in the dead band area for a time set in Dead Band Delay, the PID controller output is locked. This function prevents wear and unwanted movements of the actuators, for example valves.

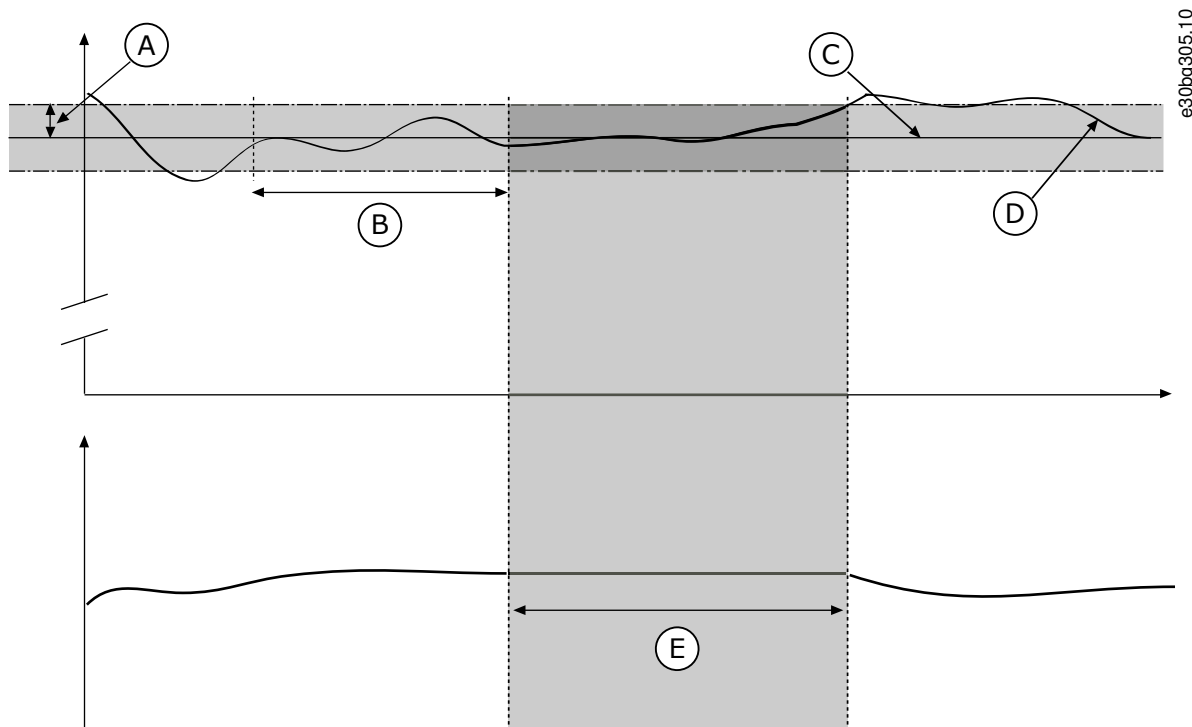

Illustration 65: The Dead Band Function

A	Dead band (ID1056)	D	Actual value
B	Dead band delay (ID1057)	E	Output locked
C	Reference		

11.16.2 Setpoints

11.16.2.1 (ID 167) Keypad Setpoint 1

Location in the menu: **P3.13.2.1**

Use this parameter to set the setpoint value of the PID controller when the setpoint source is 'Keypad SP'. The value of this parameter is given in the selected process unit.

11.16.2.2 (ID 168) Keypad Setpoint 2

Location in the menu: **P3.13.2.2**

Use this parameter to set the setpoint value of the PID controller when the setpoint source is 'Keypad SP'. The value of this parameter is given in the selected process unit.

11.16.2.3 (ID 1068) Setpoint Ramp Time

Location in the menu: **P3.13.2.3**

Use this parameter to set the rising and falling ramp times for the setpoint changes. Ramp time is the time that is necessary for the setpoint value to change from minimum to maximum. If the value of this parameter is set to 0, no ramps are used.

11.16.2.4 (ID 1046) PID Setpoint Boost Activation

Location in the menu: **P3.13.2.4**

Use this parameter to select the digital input signal that activates the boost for the PID setpoint value.

11.16.2.5 (ID 1047) PID Setpoint Selection

Location in the menu: **P3.13.2.5**

Use this parameter to set the digital input signal that selects the PID setpoint value to be used.

11.16.2.6 (ID 332) Setpoint Source 1 Selection

Location in the menu: **P3.13.2.6**

Use this parameter to select the source of the PID setpoint signal. The AIs and the ProcessDataIn are handled as percentages (0.00–100.00%) and scaled according to the setpoint minimum and maximum.

The ProcessDataIn signals use 2 decimals.

If temperature inputs are selected, the values of parameters P3.13.1.5 Process Unit Min and P3.13.1.6 Process Unit Max must be set to correspond to the scale of the temperature measurement board: ProcessUnitMin = -50 °C and ProcessUnitMax = 200 °C.

11.16.2.7 (ID 1069) Setpoint 1 Minimum

Location in the menu: **P3.13.2.7**

Use this parameter to set the minimum value of the setpoint signal.

11.16.2.8 (ID 1070) Setpoint 1 Maximum

Location in the menu: **P3.13.2.8**

Use this parameter to set the maximum value of the setpoint signal.

11.16.2.9 (ID 1071) Setpoint 1 Boost

Location in the menu: **P3.13.2.9**

Use this parameter to set the multiplier for the setpoint boost function. When the setpoint boost command is given, the setpoint value is multiplied by the factor that is set with this parameter.

11.16.2.10 (ID 431) Setpoint Source 2 Selection

Location in the menu: **P3.13.2.10**

Use this parameter to select the source of the PID setpoint signal. The AIs and the ProcessDataIn are handled as percentages (0.00–100.00%) and scaled according to the setpoint minimum and maximum.

The ProcessDataIn signals use 2 decimals.

If temperature inputs are selected, the values of parameters P3.13.1.5 Process Unit Min and P3.13.1.6 Process Unit Max must be set to correspond to the scale of the temperature measurement board: ProcessUnitMin = -50 °C and ProcessUnitMax = 200 °C.

11.16.2.11 (ID 1073) Setpoint 2 Minimum

Location in the menu: **P3.13.2.11**

Use this parameter to set the minimum value of the setpoint signal.

11.16.2.12 (ID 1074) Setpoint 2 Maximum

Location in the menu: **P3.13.2.12**

Use this parameter to set the maximum value of the setpoint signal.

11.16.2.13 (ID 1078) Setpoint 2 Boost

Location in the menu: **P3.13.2.13**

Use this parameter to set the multiplier for the setpoint boost function. When the setpoint boost command is given, the setpoint value is multiplied by the factor that is set with this parameter.

11.16.3 Feedback

11.16.3.1 (ID 333) Feedback Function

Location in the menu: **P3.13.3.1**

Use this parameter to select if the feedback value is taken from a single signal or combined from two signals. It is possible to select the mathematical function that is used when the two feedback signals are combined.

11.16.3.2 (ID 1058) Feedback Function Gain

Location in the menu: **P3.13.3.2**

Use this parameter to adjust the gain of the feedback signal. This parameter is used, for example, with the value 2 in Feedback Function.

11.16.3.3 (ID 334) Feedback 1 Source Selection

Location in the menu: **P3.13.3.3**

Use this parameter to select the source of the PID feedback signal. The AIs and the ProcessDataIn are handled as percentages (0.00–100.00%) and scaled according to the feedback minimum and maximum.

The ProcessDataIn signals use 2 decimals.

If temperature inputs are selected, the values of parameters P3.13.1.5 Process Unit Min and P3.13.1.6 Process Unit Max must be set to correspond to the scale of the temperature measurement board: ProcessUnitMin = -50 °C and ProcessUnitMax = 200 °C.

11.16.3.4 (ID 336) Feedback 1 Minimum

Location in the menu: **P3.13.3.4**

Use this parameter to set the minimum value of the feedback signal.

11.16.3.5 (ID 337) Feedback 1 Maximum

Location in the menu: **P3.13.3.5**

Use this parameter to set the maximum value of the feedback signal.

11.16.3.6 (ID 335) Feedback 2 Source Selection

Location in the menu: **P3.13.3.6**

Use this parameter to select the source of the PID feedback signal. The AIs and the ProcessDataIn are handled as percentages (0.00–100.00%) and scaled according to the feedback minimum and maximum.

The ProcessDataIn signals use 2 decimals.

If temperature inputs are selected, the values of parameters P3.13.1.5 Process Unit Min and P3.13.1.6 Process Unit Max must be set to correspond to the scale of the temperature measurement board: ProcessUnitMin = -50 °C and ProcessUnitMax = 200 °C.

11.16.3.7 (ID 338) Feedback 2 Minimum

Location in the menu: **P3.13.3.7**

Use this parameter to set the minimum value of the feedback signal.

11.16.3.8 (ID 339) Feedback 2 Maximum

Location in the menu: **P3.13.3.8**

Use this parameter to set the maximum value of the feedback signal.

11.16.4 Feedforward

11.16.4.1 (ID 1059) Feedforward Function

Location in the menu: **P3.13.4.1**

Use this parameter to select if the feedforward value is taken from a single signal or combined from two signals. It is possible to select the mathematical function that is used when the two feedforward signals are combined.

Accurate process models are necessary for the Feedforward function. In some conditions, a gain and offset type of feedforward is sufficient. The feedforward part does not use the feedback measurements of the actual controlled process value. The feedforward control uses other measurements that affect the controlled process value.

Example

It is possible to control the water level of a tank with flow control. The target water level is set as a setpoint, and the actual level as feedback. The control signal monitors the flow that comes in.

The outflow is like a disturbance that can be measured. With the measurements of the disturbance, it is possible to try to adjust this disturbance with a feedforward control (gain and offset) added to the PID output. The PID controller reacts much faster to changes in the outflow than if the level is only measured.

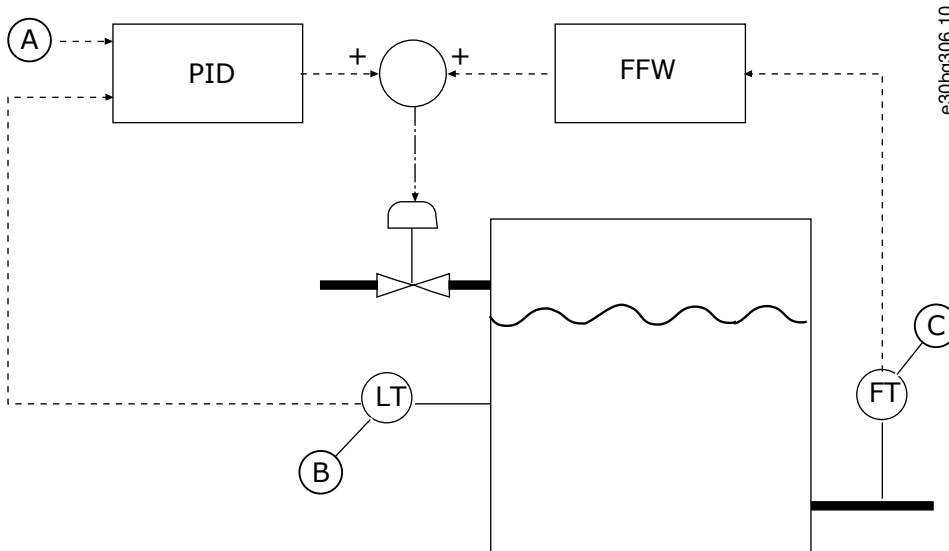

Illustration 66: The Feedforward Control

A	Level ref	C	Outflow control
B	Level control		

11.16.4.2 (ID 1060) Feedforward Gain

Location in the menu: **P3.13.4.2**

Use this parameter to adjust the gain of the feedforward signal.

11.16.4.3 (ID 1061) Feedforward 1 Source Selection

Location in the menu: **P3.13.4.3**

Use this parameter to select the source of the PID feedforward signal.

11.16.4.4 (ID 1062) Feedforward 1 Minimum

Location in the menu: **P3.13.4.4**

Use this parameter to set the minimum value of the feedforward signal.

11.16.4.5 (ID 1063) Feedforward 1 Maximum

Location in the menu: **P3.13.4.5**

Use this parameter to set the maximum value of the feedforward signal.

11.16.4.6 (ID 1064) Feedforward 2 Source Selection

Location in the menu: **P3.13.4.6**

Use this parameter to select the source of the PID feedforward signal.

11.16.4.7 (ID 1065) Feedforward 2 Minimum

Location in the menu: **P3.13.4.7**

Use this parameter to set the minimum value of the feedforward signal.

11.16.4.8 (ID 1066) Feedforward 2 Maximum

Location in the menu: **P3.13.4.8**

Use this parameter to set the maximum value of the feedforward signal.

11.16.5 Sleep Function

11.16.5.1 (ID 1016) SP1 Sleep Frequency

Location in the menu: **P3.13.5.1**

Use this parameter to set the limit below which the output frequency of the drive must stay for a set time before the drive goes to the sleep state.

The value of this parameter is used when the signal of the PID controller setpoint is taken from the setpoint source 1.

Criteria for going to sleep mode:

- Output frequency remains below sleep frequency for longer than defined sleep delay time.
- PID feedback signal remains above defined wake-up level.

Criteria for waking from sleep

- PID feedback signal falls below defined wake-up level.

NOTICE

An incorrectly set wake-up level can prevent the drive from going into sleep mode.

11.16.5.2 (ID 1017) SP1 Sleep Delay

Location in the menu: **P3.13.5.2**

Use this parameter to set the minimum duration that the output frequency of the drive must stay below the set limit before the drive goes to the sleep state. The value of this parameter is used when the signal of the PID controller setpoint is taken from the setpoint source 1.

11.16.5.3 (ID 1018) SP1 Wake-Up Level

Location in the menu: **P3.13.5.3**

Use this parameter to set the level at which the drive wakes up from the sleep state. When the PID feedback value goes below the level that is set with this parameter, drive wakes up from the sleep state. The operation of this parameter is selected with wake-up mode parameter.

This parameter automatically changes its sign based on the parameter P3.13.1.8 Error Inversion if parameter P3.13.5.4 was previously set to 1 = *Relative setpoint*. After a possible automatic sign change, the value of this parameter can be controlled freely.

11.16.5.4 (ID 1019) SP1 Wake-Up Mode

Location in the menu: **P3.13.5.4**

Use this parameter to select the operation for the wake-up level parameter. The drive wakes up from the sleep mode when the value of PID Feedback goes below the Wake-up level.

This parameter defines if Wake-up level is used as a static absolute level or as a relative level which follows PID setpoint value.

Selection number	Selection name	Description
0	Absolute level	The wake-up level is a static level that does not follow the setpoint value.
1	Relative setpoint	The wake-up level is an offset below the actual setpoint value. The wake-up level follows the actual setpoint.

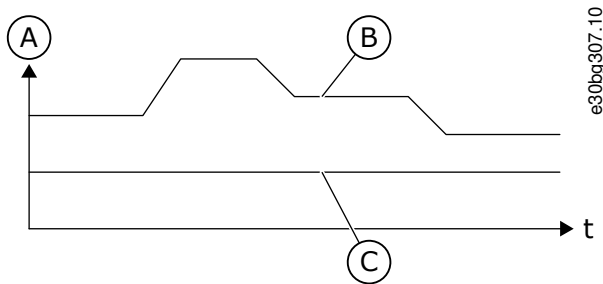

Illustration 67: Wake-up Mode: Absolute Level

A	Setpoint	C	Wake-up level
B	PID Setpoint		

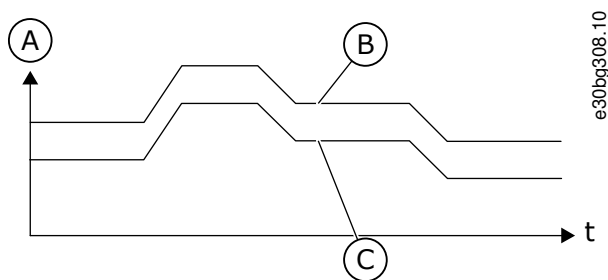

Illustration 68: Wake-up Mode: Relative Setpoint

A	Setpoint	C	Wake-up level
B	PID Setpoint		

11.16.5.5 (ID 1075) SP2 Sleep Frequency

Location in the menu: **P3.13.5.5**

Use this parameter to set the limit below which the output frequency of the drive must stay for a set time before the drive goes to the sleep state.

The value of this parameter is used when the signal of the PID controller setpoint is taken from the setpoint source 1.

Criteria for going to sleep mode:

- Output frequency remains below sleep frequency for longer than defined sleep delay time.
- PID feedback signal remains above defined wake-up level.

Criteria for waking from sleep

- PID feedback signal falls below defined wake-up level.

NOTICE

An incorrectly set wake-up level can prevent the drive from going into sleep mode.

11.16.5.6 (ID 1076) SP2 Sleep Delay

Location in the menu: **P3.13.5.6**

Use this parameter to set the minimum duration that the output frequency of the drive must stay below the set limit before the drive goes to the sleep state. The value of this parameter is used when the signal of the PID controller setpoint is taken from the setpoint source 1.

11.16.5.7 (ID 1077) SP2 Wake-Up Level

Location in the menu: **P3.13.5.7**

Use this parameter to set the level at which the drive wakes up from the sleep state. When the PID feedback value goes below the level that is set with this parameter, drive wakes up from the sleep state. The operation of this parameter is selected with wake-up mode parameter.

11.16.5.8 (ID 1020) SP2 Wake-Up Mode

Location in the menu: **P3.13.5.8**

Use this parameter to select the operation for the wake-up level parameter. The drive wakes up from the sleep mode when the value of PID Feedback goes below the Wake-up level.

This parameter defines if Wake-up level is used as a static absolute level or as a relative level which follows PID setpoint value.

Selection number	Selection name	Description
0	Absolute level	The wake-up level is a static level that does not follow the setpoint value.
1	Relative setpoint	The wake-up level is an offset below the actual setpoint value. The wake-up level follows the actual setpoint.

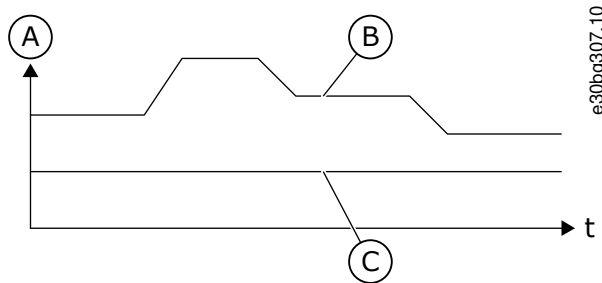

e30bg307.10

Illustration 69: Wake-up Mode: Absolute Level

A	Setpoint	C	Wake-up level
B	PID Setpoint		

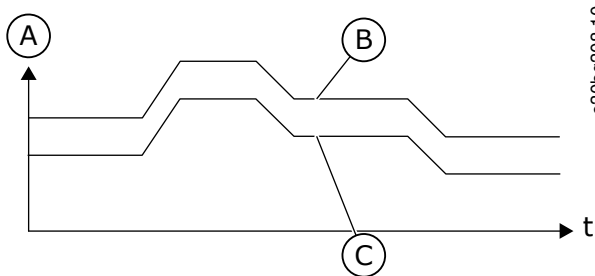

e30bg308.10

Illustration 70: Wake-up Mode: Relative Setpoint

A	Setpoint	C	Wake-up level
B	PID Setpoint		

11.16.6 Feedback Supervision

Use the feedback supervision to make sure that the PID Feedback value (the process value or the actual value) stays in the set limits. Use this function, for example, to find a pipe break and stop the flooding.

These parameters set the range in which the PID Feedback signal stays in correct conditions. If the PID Feedback signal does not stay in the range, and this continues longer than the delay, a Feedback supervision fault (the fault code 101) shows.

11.16.6.1 (ID 735) Enable Feedback Supervision

Location in the menu: **P3.13.6.1**

Use this parameter to enable the feedback supervision function. Use the feedback supervision to make sure that the PID feedback value stays in the set limits.

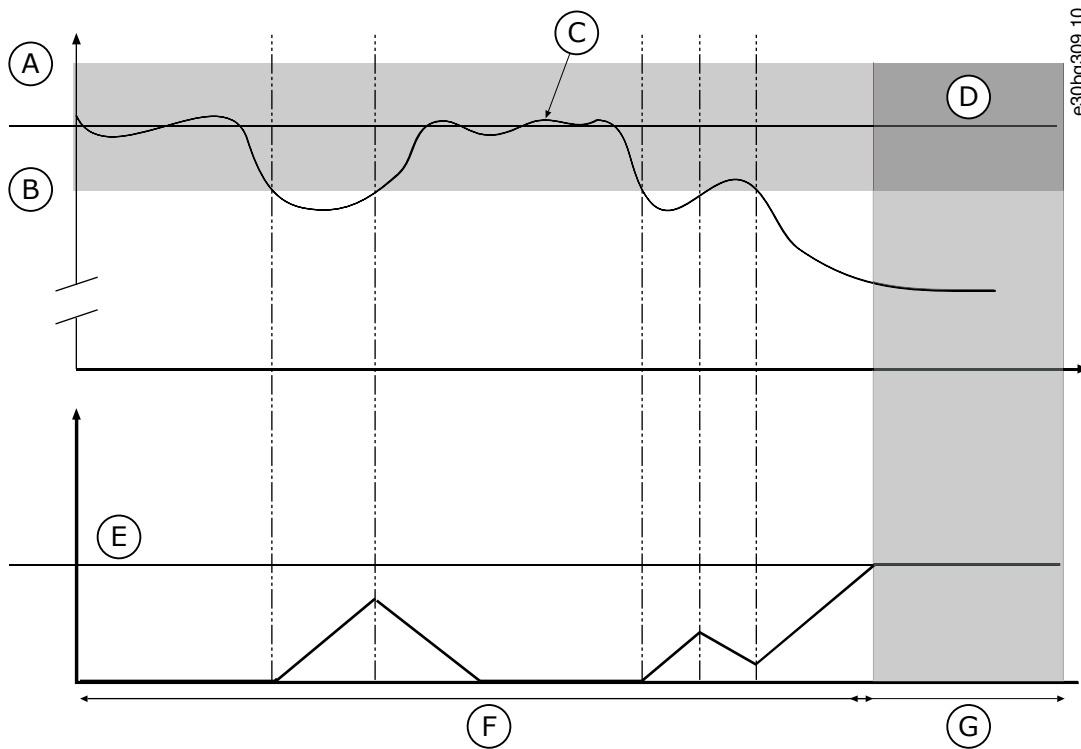

Illustration 71: The Feedback Supervision Function

A	Upper limit (ID 736)	E	Delay (ID 737)
B	Lower limit (ID 758)	F	Regulating mode
C	Actual value	G	Alarm or fault
D	Reference		

11.16.6.2 (ID 736) Upper Limit

Location in the menu: **P3.13.6.2**

Use this parameter to set the high limit for the PID feedback signal. If the value of the PID feedback signal goes above this limit for longer than the set time, a feedback supervision fault occurs.

11.16.6.3 (ID 758) Lower Limit

Location in the menu: **P3.13.6.3**

Use this parameter to set the low limit for the PID feedback signal. If the value of the PID feedback signal goes below this limit for longer than the set time, a feedback supervision fault occurs.

Set the upper limit and the lower limit around the reference. When the actual value is less or more than the limits, a counter starts to count up. When the actual value is between the limits, the counter counts down. When the counter gets a value that is higher than the value of P3.13.6.4 Delay, an alarm, or a fault shows. It is possible to select the response with parameter P3.13.6.5 (Response to PID1 Supervision Fault).

11.16.6.4 (ID 737) Delay

Location in the menu: **P3.13.6.4**

Use this parameter to set the maximum time for the PID feedback signal to stay outside the supervision limits before the feedback supervision fault occurs. If the target value is not reached in this time, a fault or alarm shows.

11.16.6.5 (ID 749) Response to PID Supervision Fault

Location in the menu: **P3.13.6.5**

Use this parameter to select the response of the drive to a 'PID Supervision' fault. If the PID feedback value is not in the supervision limits for longer than the supervision delay, a PID supervision fault occurs.

11.16.7 Pressure Loss Compensation

When pressurizing a long pipe that has many outlets, the best position for the sensor is in the middle of the pipe (the position 2 in the figure). It is also possible to put the sensor directly after the pump. This gives the right pressure directly after the pump, but farther in the pipe, the pressure drops with the flow.

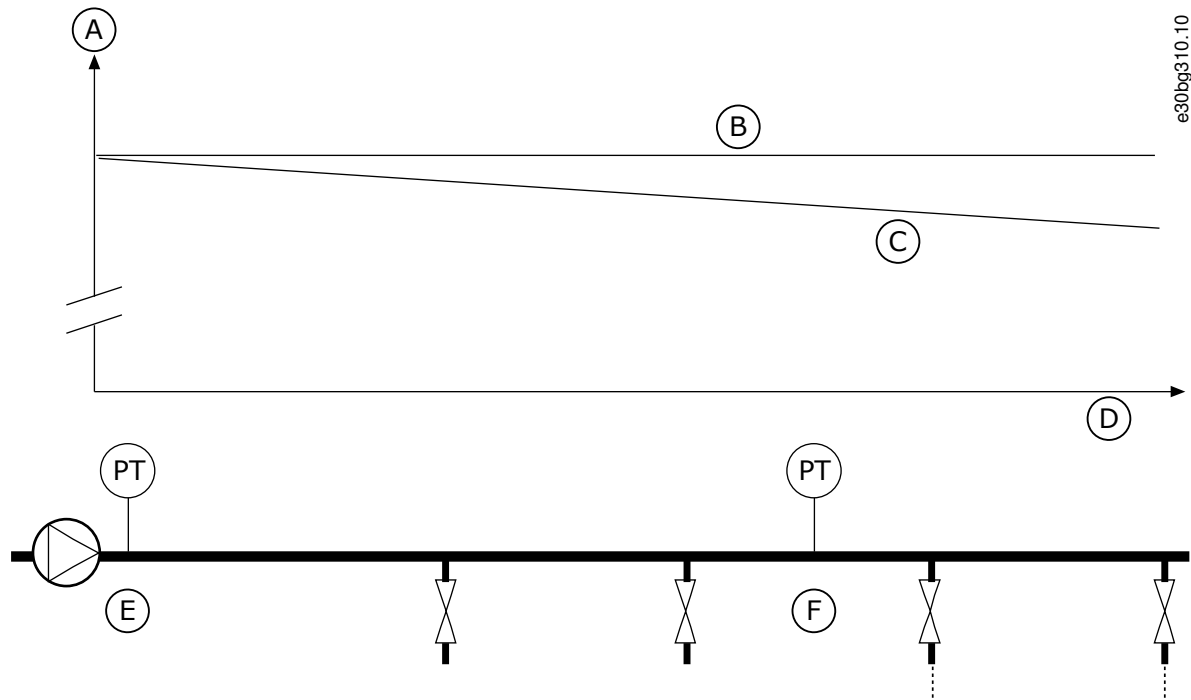

Illustration 72: The Position of the Pressure Sensor

A	Pressure	D	Pipe length
B	No flow	E	Position 1
C	With flow	F	Position 2

11.16.7.1 (ID 1189) Enable Setpoint 1

Location in the menu: **P3.13.7.1**

Use this parameter to enable the pressure loss compensation in the pump system. In a pressure-controlled system, this function compensates the pressure loss that occurs at the end of the pipe line due to the liquid flow.

11.16.7.2 (ID 1190) Setpoint 1 Max Compensation

Location in the menu: **P3.13.7.2**

Use this parameter to set the maximum compensation for PID setpoint value that is applied when the output frequency of the drive is at the maximum frequency. The compensation value is added to the actual setpoint value as a function of the output frequency. $\text{Setpoint compensation} = \text{max compensation} * (\text{FreqOut} - \text{MinFreq}) / (\text{MaxFreq} - \text{MinFreq})$.

The sensor is put in position 1. The pressure in the pipe stays constant when there is no flow. But with flow, the pressure decreases farther in the pipe. To compensate for this, lift the setpoint as the flow increases. Then the output frequency makes an estimate of the flow, and the setpoint increases linearly with the flow.

e30bg311.10

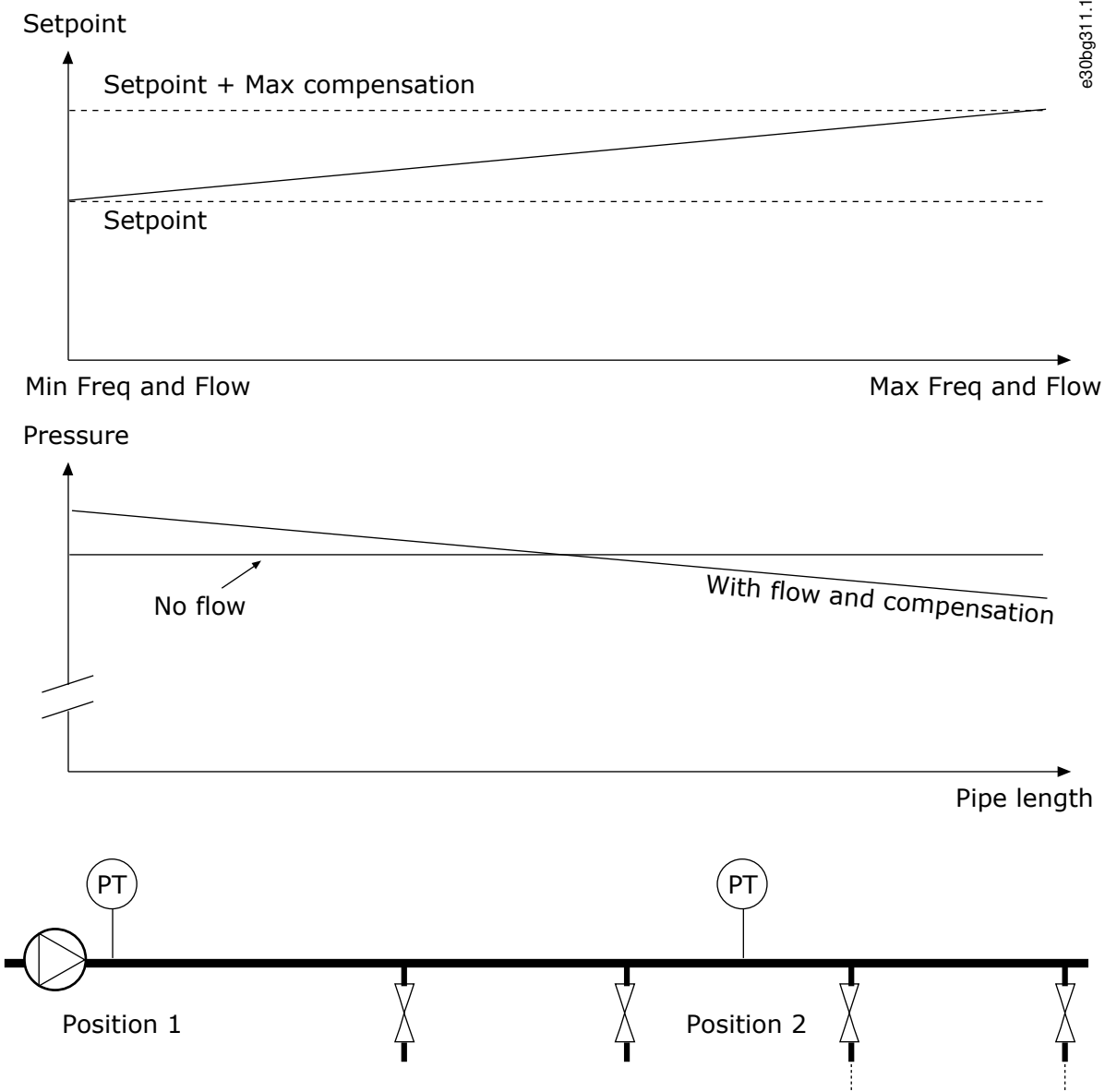

Illustration 73: Enable Setpoint 1 for Pressure Loss Compensation

11.16.7.3 (ID 1191) Enable Setpoint 2

Location in the menu: **P3.13.7.3**

Use this parameter to enable the pressure loss compensation in the pump system. In a pressure-controlled system, this function compensates the pressure loss that occurs at the end of the pipe line due to the liquid flow.

11.16.7.4 (ID 1192) Setpoint 2 Max Compensation

Location in the menu: **P3.13.7.4**

Use this parameter to set the maximum compensation for PID setpoint value that is applied when the output frequency of the drive is at the maximum frequency. The compensation value is added to the actual setpoint value as a function of the output frequency. $\text{Setpoint compensation} = \text{max compensation} * (\text{FreqOut} - \text{MinFreq}) / (\text{MaxFreq} - \text{MinFreq})$.

The sensor is put in position 1. The pressure in the pipe stays constant when there is no flow. But with flow, the pressure decreases farther in the pipe. To compensate for this, lift the setpoint as the flow increases. Then the output frequency makes an estimate of the flow, and the setpoint increases linearly with the flow.

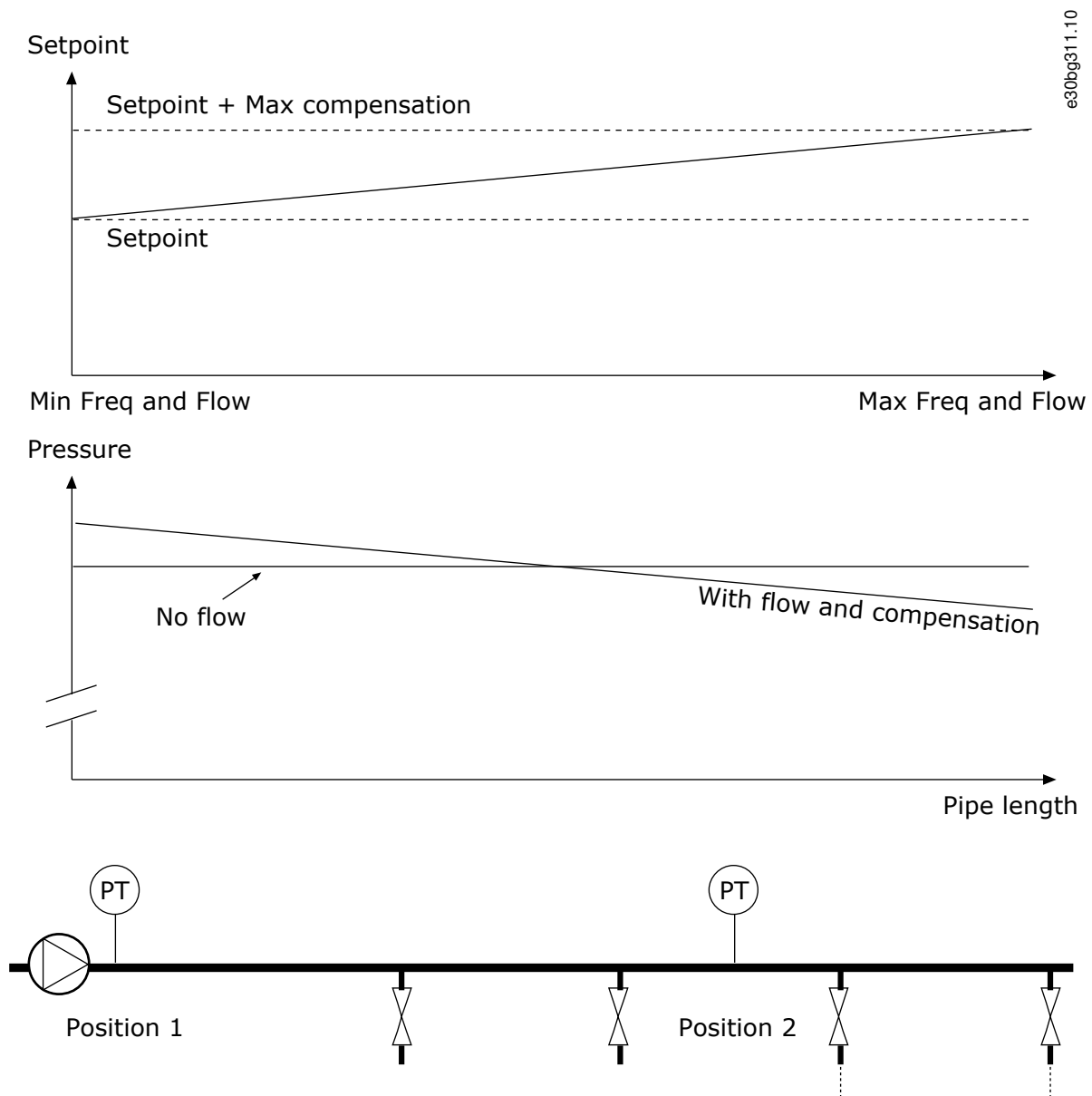

Illustration 74: Enable Setpoint 1 for Pressure Loss Compensation

11.16.8 Soft Fill

The Soft fill function is used to move the process to a set level at a slow speed before the PID controller starts to control. If the process does not go to the set level during the timeout, a fault shows.

It is possible to use the function to fill an empty pipe slowly and prevent strong currents of water that could break the pipe.

We recommend always using the Soft fill function when using the Multi-pump function.

11.16.8.1 (ID 1094) Enable Soft Fill

Location in the menu: **P3.13.8.1**

Use this parameter to enable the Soft Fill function. It is possible to use the function to fill an empty pipe slowly and prevent strong currents of fluid that could break the pipe.

11.16.8.2 (ID 1055) Soft Fill Frequency

Location in the menu: **P3.13.8.2**

Use this parameter to set the frequency reference of the drive when the Soft Fill function is used. The drive accelerates to this frequency before it starts to control. After this, the drive goes to normal PID control mode.

11.16.8.3 (ID 1095) Soft Fill Level

Location in the menu: **P3.13.8.3**

Use this parameter to set the level below which the soft fill control is enabled when starting the drive. The drive operates at the PID start frequency until the feedback reaches the set value. Then the PID controller starts to control the drive. This parameter is applied if the soft fill function is set to 'Enabled, Level'.

11.16.8.4 (ID 1096) Soft Fill Timeout

Location in the menu: **P3.13.8.4**.

Use this parameter to set the timeout time for the Soft Fill function. When the soft fill function is set to 'Enabled, Level', this parameter gives the timeout for the soft fill level, after which the soft fill fault occurs. When the soft fill function is set to 'Enabled, Timeout', the drive operates at the soft fill frequency until the time set by this parameter expires.

The drive operates at the soft fill frequency until the feedback value is equal with the soft fill level. If the feedback value does not become equal with the soft fill level during the timeout, an alarm, or fault shows. It is possible to select the response with parameter P3.13.8.5 (PID Soft Fill Timeout Response).

NOTICE

If the value is set to 0, no fault shows.

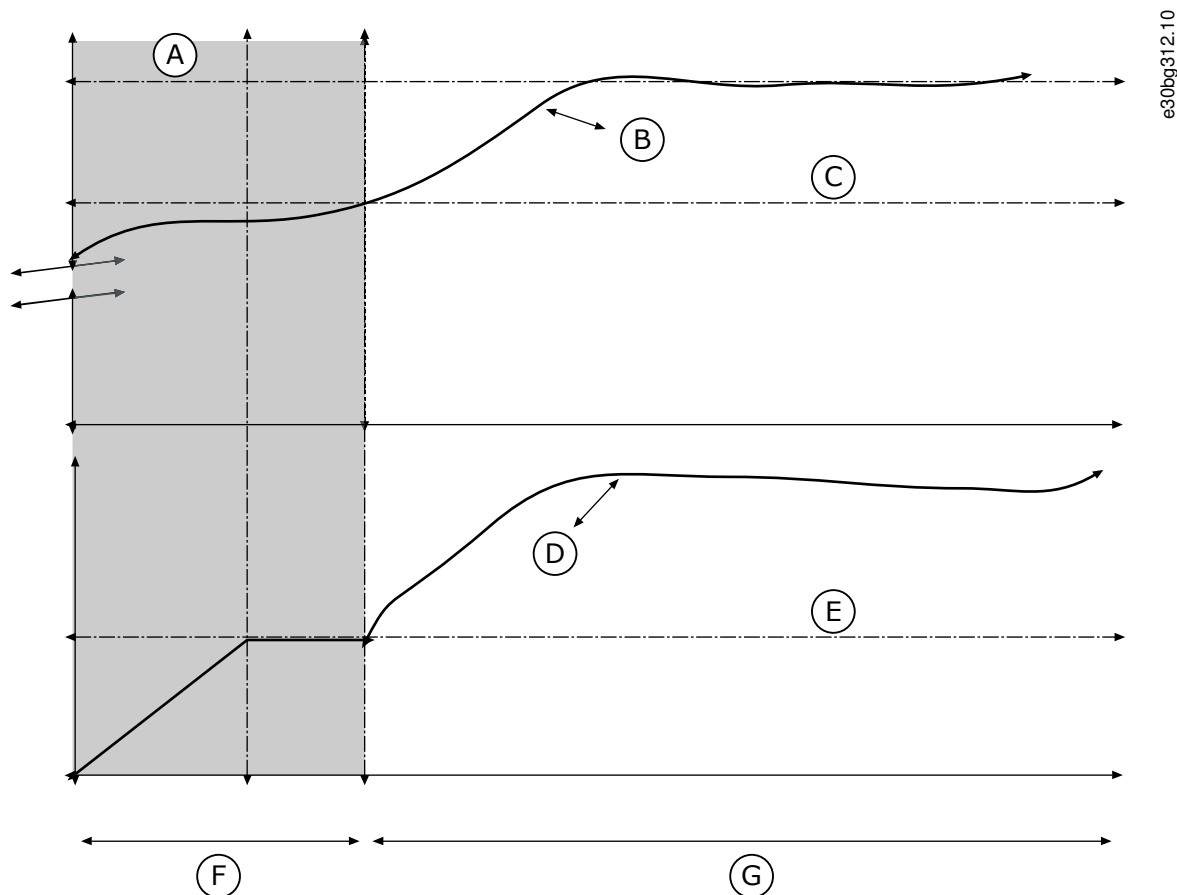

Illustration 75: The Soft Fill Function

A	Reference	E	Soft fill frequency
B	Actual value	F	Soft fill mode
C	Soft fill level	G	Regulating mode
D	Frequency		

11.16.8.5 (ID 748) PID Soft Fill Timeout Response

Location in the menu: **P3.13.8.5**.

Use this parameter to select the response of the drive to a 'PID Soft Fill' fault. If the PIDFeedback value does not reach the set level in the time limit, a soft fill fault occurs.

11.16.9 Input Pressure Supervision

Use the Input pressure supervision to make sure that there is enough water in the inlet of the pump. When there is enough water, the pump does not suck air and there is no suction cavitation. To use the function, install a pressure sensor on the pump inlet.

If the input pressure of the pump goes below the set alarm limit, an alarm shows. The setpoint value of the PID controller decreases and causes the output pressure of the pump to decrease. If the pressure goes below the fault limit, the pump is stops and a fault shows.

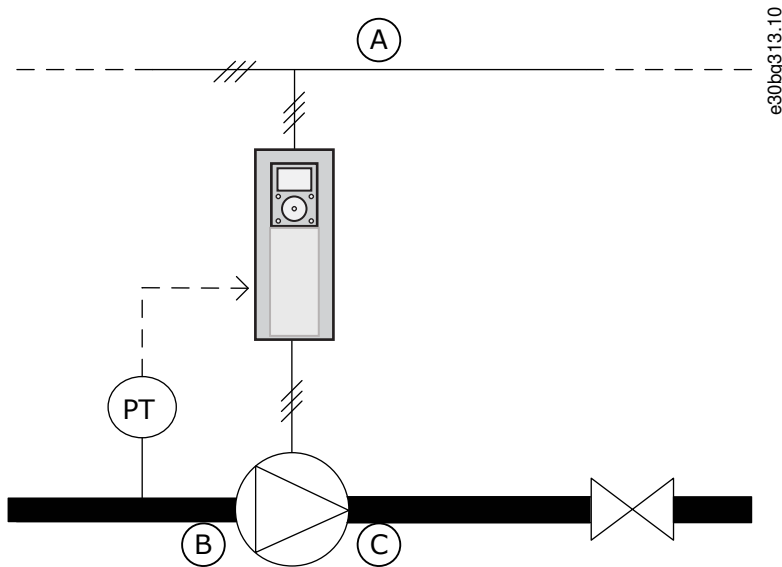
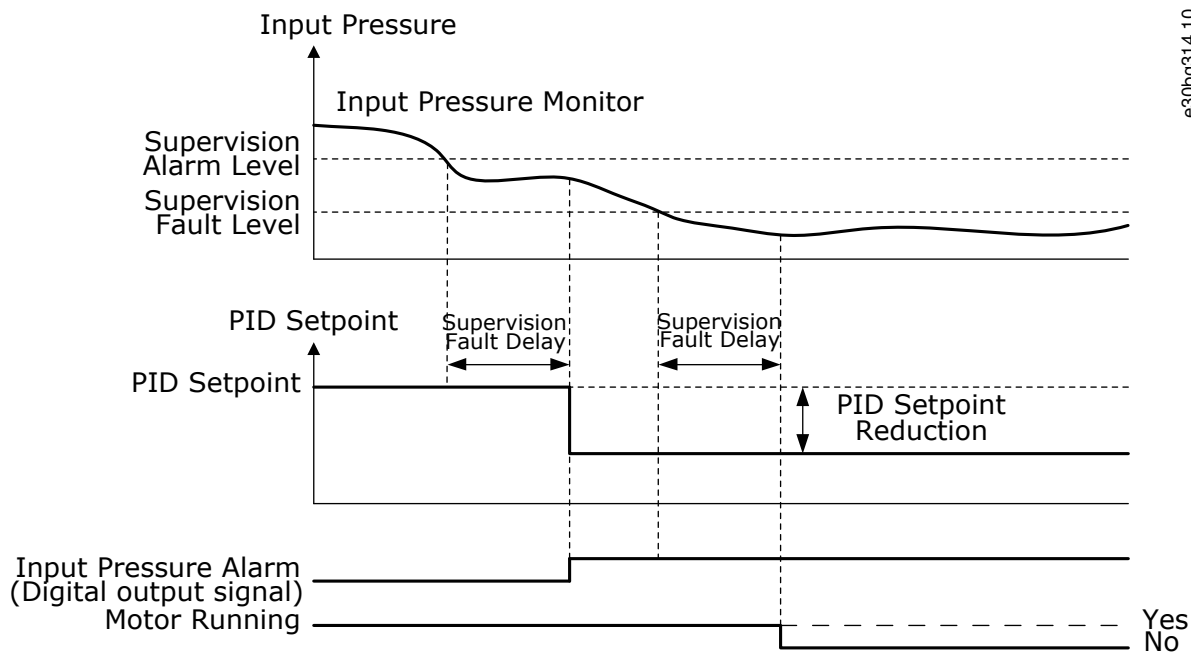

Illustration 76: The Location of the Pressure Sensor

A	Mains	C	Outlet
B	Inlet		



e30bg314.10

Illustration 77: The Input Pressure Supervision Function

11.16.9.1 (ID 1685) Enable Supervision

Location in the menu: **P3.13.9.1**

Use this parameter to enable the Input Pressure Supervision function. Use this function to make sure that there is enough fluid in the inlet of the pump.

11.16.9.2 (ID 1686) Supervision Signal

Location in the menu: **P3.13.9.2**

Use this parameter to select the source of the input pressure signal.

11.16.9.3 (ID 1687) Supervision Unit Selection

Location in the menu: **P3.13.9.3**

Use this parameter to select the unit for the input pressure signal. It is possible to scale the supervision signal (P3.13.9.2) to process units on the panel.

11.16.9.4 (ID 1688) Supervision Unit Decimals

Location in the menu: **P3.13.9.4**

Use this parameter to set the number of decimals for the input pressure signal unit. It is possible to scale the supervision signal (P3.13.9.2) to process units on the panel.

11.16.9.5 (ID 1689) Supervision Unit Minimum Value

Location in the menu: **P3.13.9.5**

Use this parameter to set the minimum value of the input pressure signal. Enter the value in the selected process unit. For example, an analog signal of 4...20 mA corresponds to the pressure of 0...10 bar.

11.16.9.6 (ID 1690) Supervision Unit Maximum Value

Location in the menu: **P3.13.9.6**

Use this parameter to set the maximum value of the input pressure signal. Enter the value in the selected process unit. For example, an analog signal of 4...20 mA corresponds to the pressure of 0...10 bar.

11.16.9.7 (ID 1691) Supervision Alarm Level

Location in the menu: **P3.13.9.7**

Use this parameter to set the limit for the input pressure alarm. If the measured input pressure goes below this limit, an input pressure alarm occurs.

11.16.9.8 (ID 1692) Supervision Fault Level

Location in the menu: **P3.13.9.8**

Use this parameter to set the limit for the input pressure fault. If the measured input pressure stays below this level for longer than the set time, an input pressure fault occurs.

11.16.9.9 (ID 1693) Supervision Fault Delay

Location in the menu: **P3.13.9.9**

Use this parameter to set the maximum duration for the input pressure to stay below the fault limit before an input pressure fault occurs.

11.16.9.10 (ID 1694) PID Setpoint Reduction

Location in the menu: **P3.13.9.10**

Use this parameter to set the rate of the reduction of the PID setpoint value when the measured input pressure is below the alarm limit.

11.16.9.11 (ID 1695) Input Pressure

Location in the menu: **V3.13.9.11**

This monitoring value shows the actual value of the pump input pressure.

11.16.10 Frost Protection

Use the Frost protection function to protect the pump from frost damages. If the pump is in sleep mode and the temperature that is measured in the pump goes below the set protection temperature, operate the pump at a constant frequency (that is set in P3.13.10.6 Frost Protection Frequency). To use the function, install a temperature transducer or a temperature sensor on the pump covering or on the pipe line near the pump.

11.16.10.1 (ID 1704) Frost Protection

Location in the menu: **P3.13.10.1**

Use this parameter to enable the Frost Protection function. If the measured temperature of the pump goes below the set level and the drive is in sleep state, the frost protection starts the pump to operate at a constant frequency.

11.16.10.2 (ID 1705) Temperature Signal

Location in the menu: **P3.13.10.2**

Use this parameter to select the source of the temperature signal that is used for the Frost Protection function.

11.16.10.3 (ID 1706) Temperature Signal Minimum

Location in the menu: **P3.13.10.3**

Use this parameter to set the minimum value of the temperature signal. For example, a temperature signal range of 4...20 mA corresponds to the temperature of -50...200 °C.

11.16.10.4 (ID 1707) Temperature Signal Maximum

Location in the menu: **P3.13.10.4**

Use this parameter to set the maximum value of the temperature signal. For example, a temperature signal range of 4...20 mA corresponds to the temperature of -50...200 °C.

11.16.10.5 (ID 1708) Frost Protection Temperature

Location in the menu: **P3.13.10.5**

Use this parameter to set the temperature limit at which the drive starts. If the temperature of the pump goes below this limit and the drive is in the sleep state, the frost protection function starts the drive.

11.16.10.6 (ID 1710) Frost Protection Frequency

Location in the menu: **P3.13.10.6**

Use this parameter to set the frequency reference of the drive that is used when the frost protection function is activated.

11.16.10.7 (ID 1711) Frost Temperature Monitoring

Location in the menu: **P3.13.10.7**

The monitoring value for the measured temperature signal in the Frost protection function. Scaling value: 0.1.

11.17 External PID Controller

11.17.1 Basic Settings

11.17.1.1 (ID 1630) Enable External PID

Location in the menu: **P3.14.1.1**

Use this parameter to enable the PID controller.

This controller is for external use only. It can be used with an analog output.

11.17.1.2 (ID 1049) Start Signal

Location in the menu: **P3.14.1.2**

Use this parameter to set the signal for starting and stopping the PID controller 2 for external usage.

If the PID2 controller is not enabled in the Basic menu for PID2, this parameter has no effect.

11.17.1.3 (ID 1100) Output in Stop

Location in the menu: **P3.14.1.3**

Use this parameter to set the output value of the PID controller as a percentage of its maximum output value when it is stopped from a digital output. If the value of this parameter is set to 100%, a 10% change in the error value causes a 10% change in the controller output.

11.17.1.4 (ID 1631) PID Gain

Location in the menu: **P3.14.1.4**

Use this parameter to adjust the gain of the external PID controller. If this parameter is set to 100%, a change of 10% in the error value causes the controller output to change by 10%.

11.17.1.5 (ID 1632) PID Integration Time

Location in the menu: **P3.14.1.5**

Use this parameter to adjust the integration time of the external PID controller. If this parameter is set to 1.00 s, a change of 10% in the error value causes the controller output to change by 10.00%/s.

11.17.1.6 (ID 1633) PID Derivation Time

Location in the menu: **P3.14.1.6**

Use this parameter to adjust the derivation time of the external PID controller. If this parameter is set to 1.00 s, a change of 10% in the error value during 1.00 s causes the controller output to change by 10.00%.

11.17.1.7 (ID 1635) Process Unit Selection

Location in the menu: **P3.14.1.7**

Use this parameter to select the unit for the feedback and the setpoint signals of the external PID controller. Select the unit for the actual value.

11.17.1.8 (ID 1664) Process Unit Min

Location in the menu: **P3.14.1.8**

Use this parameter to set the minimum value of the PID feedback signal. For example, an analog signal of 4...20 mA corresponds to the pressure of 0...10 bar. The value in process units at a 0% feedback or setpoint. This scaling is done for monitoring purposes only. The external PID controller still uses the percentage internally for feedbacks and setpoints.

11.17.1.9 (ID 1665) Process Unit Max

Location in the menu: **P3.14.1.9**

Use this parameter to set the maximum value of the PID feedback signal. For example, an analog signal of 4...20 mA corresponds to the pressure of 0...10 bar. The value in process units at a 0% feedback or setpoint. This scaling is done for monitoring purposes only. The external PID controller still uses the percentage internally for feedbacks and setpoints.

11.17.1.10 (ID 1666) Process Unit Decimals

Location in the menu: **P3.14.1.10**

Use this parameter to set the number of decimals for the process unit values. For example, an analog signal of 4...20 mA corresponds to the pressure of 0...10 bar. The value in process units at a 0% feedback or setpoint. This scaling is done for monitoring purposes only. The external PID controller still uses the percentage internally for feedbacks and setpoints.

11.17.1.11 (ID 1636) Error Inversion

Location in the menu: **P3.14.1.11**

Use this parameter to invert the error value of the external PID controller.

11.17.1.12 (ID 1637) Dead Band

Location in the menu: **P3.14.1.12**

Use this parameter to set the dead band area around the PID setpoint value. The value of this parameter is given in the selected process unit. The output of the external PID controller is locked if the feedback value stays in the dead band area for the set time.

11.17.1.13 (ID 1638) Dead Band Delay

Location in the menu: **P3.14.1.13**

Use this parameter to set the time that the feedback value must stay in the dead band area before the output of the PID controller is locked. If the actual value stays in the dead band area for a time set in Dead Band Delay, the PID controller output is locked. This function prevents wear and unwanted movements of the actuators, for example valves.

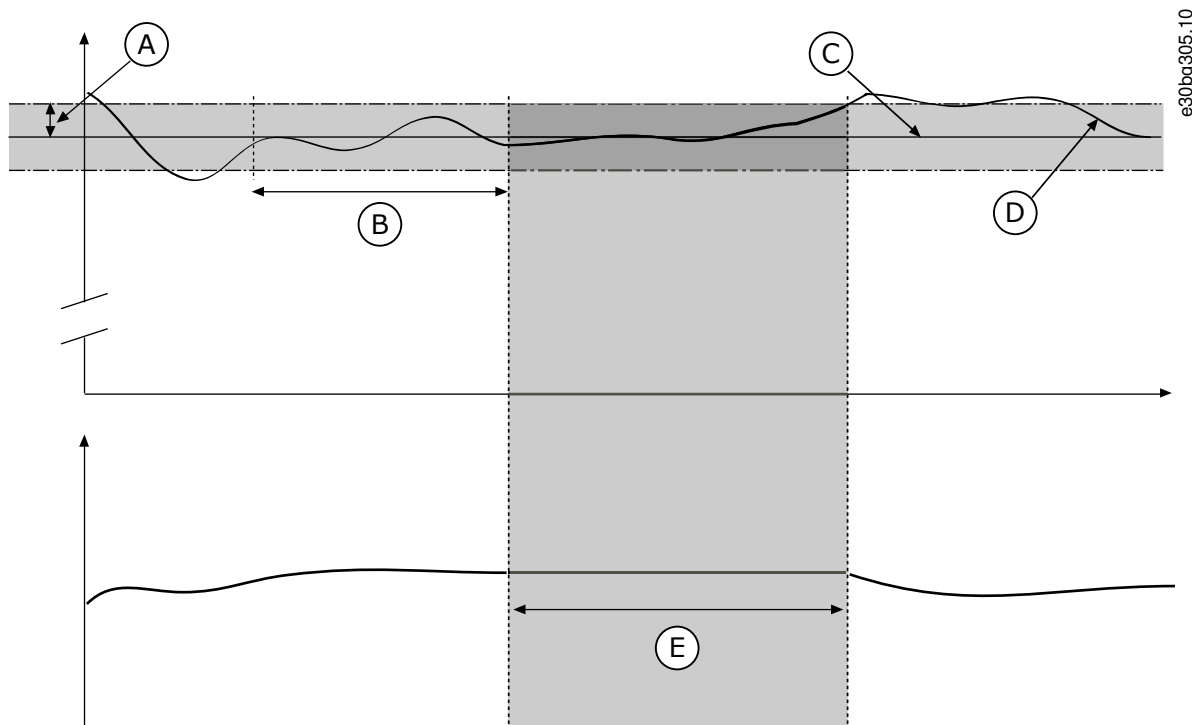

Illustration 78: The Dead Band Function

A	Dead band (ID 1637)	D	Actual value
B	Dead band delay (ID 1638)	E	Output locked
C	Reference		

11.17.2 Setpoints

11.17.2.1 (ID 1640) Keypad Setpoint 1

Location in the menu: **P3.14.2.1**

Use this parameter to set the setpoint value of the PID controller when the setpoint source is 'Keypad SP'. The value of this parameter is given in the selected process unit.

11.17.2.2 (ID 1641) Keypad Setpoint 2

Location in the menu: **P3.14.2.2**

Use this parameter to set the setpoint value of the PID controller when the setpoint source is 'Keypad SP'. The value of this parameter is given in the selected process unit.

11.17.2.3 (ID 1642) Setpoint Ramp Time

Location in the menu: **P3.14.2.3**

Use this parameter to set the rising and falling ramp times for the setpoint changes. Ramp time is the time that is necessary for the setpoint value to change from minimum to maximum. If the value of this parameter is set to 0, no ramps are used.

11.17.2.4 (ID 1048) Select Setpoint

Location in the menu: **P3.14.2.4**

Use this parameter to set the digital input signal that selects the PID setpoint value to be used.

11.17.2.5 (ID 1643) Setpoint Source 1 Selection

Location in the menu: **P3.14.2.5**

Use this parameter to select the source of the PID setpoint signal. The AIs and the ProcessDataIn are handled as percentages (0.00–100.00%) and scaled according to the setpoint minimum and maximum.

The ProcessDataIn signals use 2 decimals.

If temperature inputs are selected, the values of parameters P3.14.1.8 Process Unit Min and P3.14.1.9 Process Unit Max must be set to correspond to the scale of the temperature measurement board.

11.17.2.6 (ID 1644) Setpoint 1 Minimum

Location in the menu: **P3.14.2.6**

Use this parameter to set the minimum value of the setpoint signal.

11.17.2.7 (ID 1645) Setpoint 1 Maximum

Location in the menu: **P3.14.2.7**

Use this parameter to set the maximum value of the setpoint signal.

11.17.2.8 (ID 1646) Setpoint Source 2 Selection

Location in the menu: **P3.14.2.8**

Use this parameter to select the source of the PID setpoint signal. The AIs and the ProcessDataIn are handled as percentages (0.00–100.00%) and scaled according to the setpoint minimum and maximum.

The ProcessDataIn signals use 2 decimals.

If temperature inputs are selected, the values of parameters P3.14.1.8 Process Unit Min and P3.14.1.9 Process Unit Max must be set to correspond to the scale of the temperature measurement board.

11.17.2.9 (ID 1647) Setpoint 2 Minimum

Location in the menu: **P3.14.2.9**

Use this parameter to set the minimum value of the setpoint signal.

11.17.2.10 (ID 1648) Setpoint 2 Maximum

Location in the menu: **P3.14.2.10**

Use this parameter to set the maximum value of the setpoint signal.

11.17.3 Feedback

11.17.3.1 (ID 1650) Feedback Function

Location in the menu: **P3.14.3.1**

Use this parameter to select if the feedback value is taken from a single signal or combined from two signals. It is possible to select the mathematical function that is used when the two feedback signals are combined.

11.17.3.2 (ID 1651) Feedback Function Gain

Location in the menu: **P3.14.3.2**

Use this parameter to adjust the gain of the feedback signal. This parameter is used, for example, with the value 2 in Feedback Function.

11.17.3.3 (ID 1652) Feedback 1 Source Selection

Location in the menu: **P3.14.3.3**

Use this parameter to select the source of the PID feedback signal. The AIs and the ProcessDataIn are handled as percentages (0.00–100.00%) and scaled according to the feedback minimum and maximum.

The ProcessDataIn signals use 2 decimals.

If temperature inputs are selected, the values of parameters P3.13.1.5 Process Unit Min and P3.13.1.6 Process Unit Max must be set to correspond to the scale of the temperature measurement board: ProcessUnitMin = -50 °C and ProcessUnitMax = 200 °C.

11.17.3.4 (ID 1653) Feedback 1 Minimum

Location in the menu: **P3.14.3.4**

Use this parameter to set the minimum value of the feedback signal.

11.17.3.5 (ID 1654) Feedback 1 Maximum

Location in the menu: **P3.14.3.5**

Use this parameter to set the maximum value of the feedback signal.

11.17.3.6 (ID 1655) Feedback 2 Source Selection

Location in the menu: **P3.14.3.6**

Use this parameter to select the source of the PID feedback signal. The AIs and the ProcessDataIn are handled as percentages (0.00–100.00%) and scaled according to the feedback minimum and maximum.

The ProcessDataIn signals use 2 decimals.

If temperature inputs are selected, the values of parameters P3.13.1.5 Process Unit Min and P3.13.1.6 Process Unit Max must be set to correspond to the scale of the temperature measurement board: ProcessUnitMin = -50 °C and ProcessUnitMax = 200 °C.

11.17.3.7 (ID 1656) Feedback 2 Minimum

Location in the menu: **P3.14.3.7**

Use this parameter to set the minimum value of the feedback signal.

11.17.3.8 (ID 1657) Feedback 2 Maximum

Location in the menu: **P3.14.3.8**

Use this parameter to set the maximum value of the feedback signal.

11.17.4 Feedback Supervision

11.17.4.1 (ID 1659) Enable Supervision

Location in the menu: **P3.14.4.1**

Use this parameter to enable the feedback supervision function. Use the feedback supervision to make sure that the PID feedback value stays in the set limits.

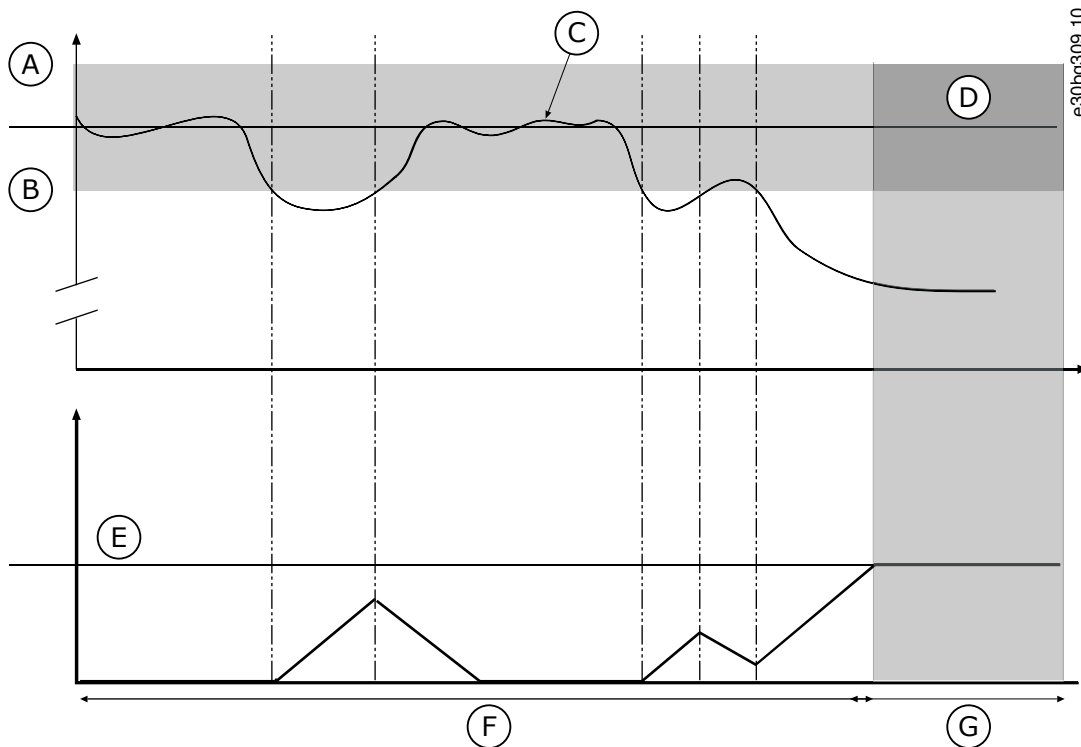

Illustration 79: The Supervision Function

A	Upper limit (ID 1660)	E	Delay (ID 1662)
B	Lower limit (ID 1661)	F	Regulating mode
C	Actual value	G	Alarm or fault
D	Reference		

11.17.4.2 (ID 1660) Upper Limit

Location in the menu: **P3.14.4.2**

Use this parameter to set the high limit for the PID feedback signal. If the value of the PID feedback signal goes above this limit for longer than the set time, a feedback supervision fault occurs.

11.17.4.3 (ID 1661) Lower Limit

Location in the menu: **P3.14.4.3**

Use this parameter to set the low limit for the PID feedback signal. If the value of the PID feedback signal goes below this limit for longer than the set time, a feedback supervision fault occurs.

Set the upper limit and the lower limit around the reference. When the actual value is less or more than the limits, a counter starts to count up. When the actual value is between the limits, the counter counts down. When the counter gets a value that is higher than the value of P3.14.4.4 Delay, an alarm or a fault shows. It is possible to select the response with parameter P3.14.4.5 (Response to External PID Supervision Fault).

11.17.4.4 (ID 1662) Delay

Location in the menu: **P3.14.4.4**

Use this parameter to set the maximum time for the PID feedback signal to stay outside the supervision limits before the feedback supervision fault occurs. If the target value is not reached in this time, a fault or alarm shows.

11.17.4.5 (ID 757) Response to External PID Supervision Fault

Location in the menu: **P3.14.4.5**

Use this parameter to select the response of the drive to a 'PID Supervision' fault. If the PID feedback value is not in the supervision limits for longer than the supervision delay, a PID supervision fault occurs.

11.18 Multi-pump Function

11.18.1 The Multi-pump Function

The Multi-pump function allows controlling a maximum of 6 motors, pumps, or fans with the PID controller.

The AC drive is connected to a motor, which is the regulating motor. The regulating motor connects and disconnects the other motors to/from the mains with relays. It is done to keep the right setpoint. The Autochange function controls the sequence in which the motors start to make sure that they wear equally. It is possible to include the regulating motor in the autochange and interlock logic, or set it to be always Motor 1. It is possible to remove motors momentarily with the Interlock function, for example for maintenance.

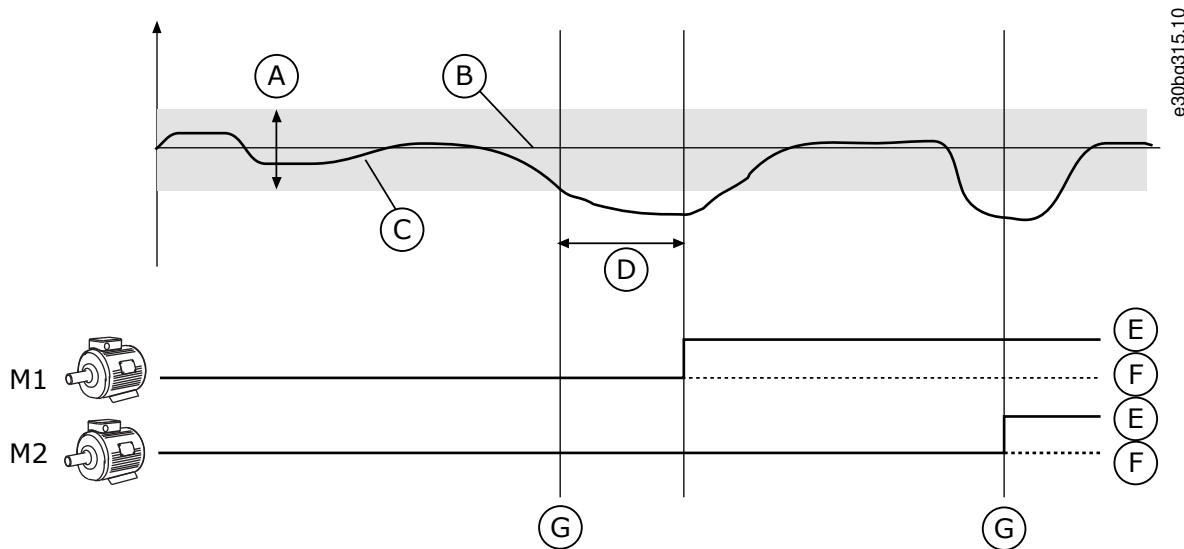

Illustration 80: The Multi-pump Function

A	Bandwidth	E	ON
B	Setpoint	F	OFF
C	Feedback	G	Drive is running at maximum or close to maximum frequency
D	Delay		

If the PID controller cannot keep the feedback in the set bandwidth, a motor, or motors are connected or disconnected.

When to connect and/or add motors:

- The feedback value is not in the bandwidth area.
- The regulating motor operates at a close to maximum frequency (-2 Hz).
- The 2 previous conditions are true for longer than the bandwidth delay.
- There are more motors available.

When to disconnect and/or remove motors:

- The feedback value is not in the bandwidth area.
- The regulating motor operates at a close to minimum frequency (+2 Hz).
- The 2 previous conditions are true for longer than the bandwidth delay.
- There are more motors that operate than the regulating one.

11.18.2 (ID 1001) Number of Motors

Location in the menu: P3.15.1

Use this parameter to set the total number of motors/pumps used with the multi-pump system.

11.18.3 (ID 1032) Interlock Function

Location in the menu: **P3.15.2**

Use this parameter to enable or disable the interlocks. The interlocks tell the Multi-pump system that a motor is not available. It can occur when the motor is removed from the system for maintenance or bypassed for manual control.

To use the interlocks, enable the parameter P3.15.2. Select the status for each motor with a digital input (the parameters from P3.5.1.34 to P3.5.1.39). If the value of the input is CLOSED, that is, active, the motor is available for the Multi-pump system. If not, the Multi-pump logic does not connect it.

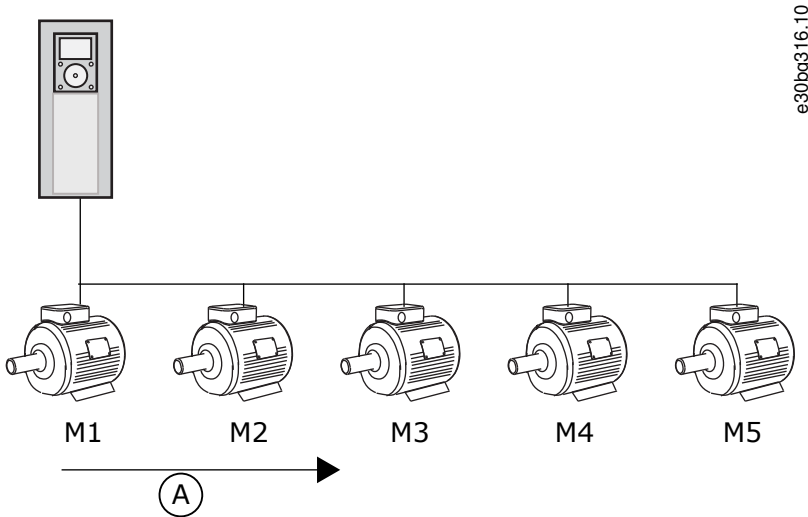

Illustration 81: The Interlock Logic 1

A Starting order of motors

The sequence of the motors is **1, 2, 3, 4, 5**. If the interlock of Motor 3, is removed, that is, the value of P3.5.1.36 is set to OPEN, the sequence changes to **1, 2, 4, 5**.

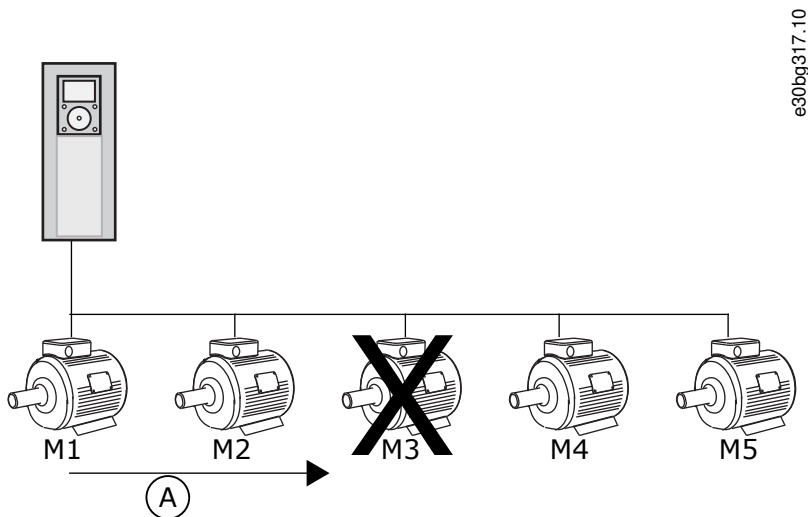

Illustration 82: The Interlock Logic 2, ID 428 = FALSE

A Starting order of motors

If Motor 3 is added again (the value of P3.5.1.36 is set to CLOSED), the system puts Motor 3 last in the sequence: **1, 2, 4, 5, 3**. The system does not stop, but continues to operate.

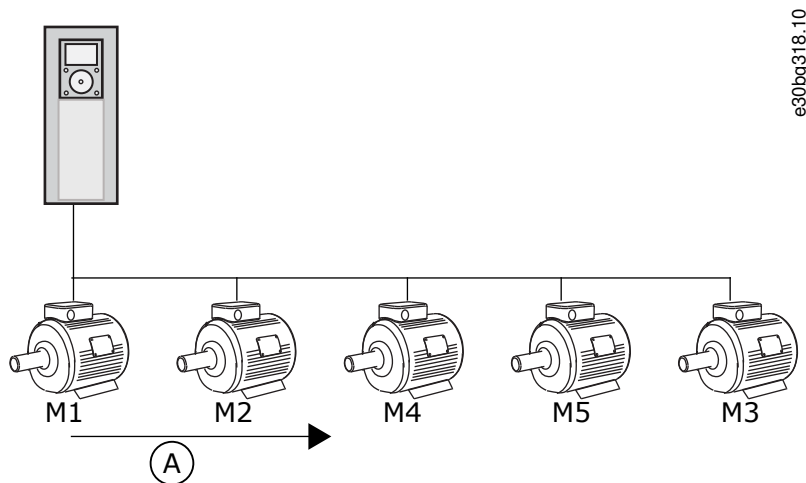

Illustration 83: The Interlock Logic 3, ID 428 = TRUE

A New starting order of motors

When the system stops or goes to sleep mode for the next time, the sequence changes back to **1, 2, 3, 4, 5**.

11.18.4 (ID 1028) Include FC

Location in the menu: **P3.15.3**

Use this parameter to include the controlled motor/pump in the autochange and interlock system. If the controlled motor/pump is not included, the controlling motor always is motor number 1. Refer to the manual for wiring diagrams in both cases.

Selection number	Selection name	Description
0	Disabled	The drive is always connected to Motor 1. The interlocks do not affect Motor 1. Motor 1 is not included in the autochange logic.
1	Enabled	It is possible to connect the drive to any of the motors in the system. The interlocks affect all the motors. All the motors are included in the autochange logic.

The connections are different for the parameter values 0 and 1.

SELECTION 0, DISABLED

The drive is directly connected to Motor 1. The other motors are auxiliary motors. They are connected to the mains by contactors, and controlled by relays of the drive. The autochange or the interlock logic does not affect Motor 1.

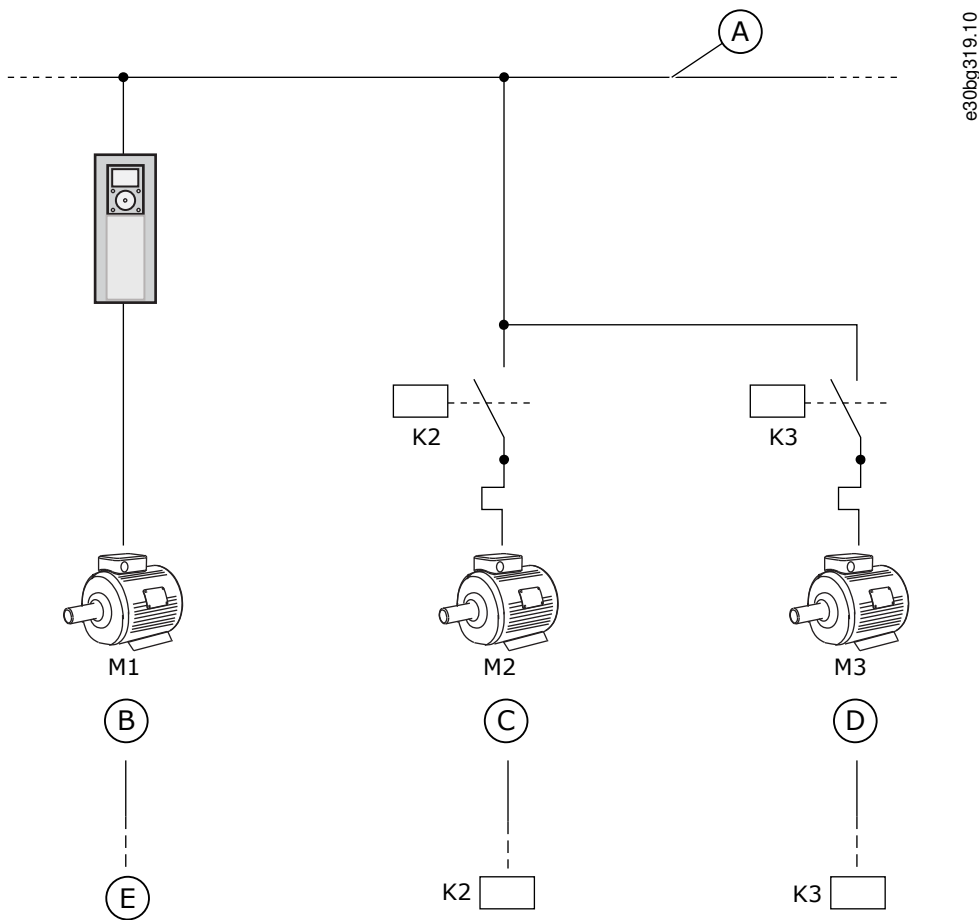

Illustration 84: Selection 0

A	Mains	D	Motor 3 control from relay
B	Motor 1 control from relay	E	Not used
C	Motor 2 control from relay		

SELECTION 1, ENABLED

To include the regulating motor in the autochange or in the interlock logic, obey the instructions in the following figure. 1 relay controls each motor. The contactor logic always connects the first motor to the drive, and the next motors to the mains.

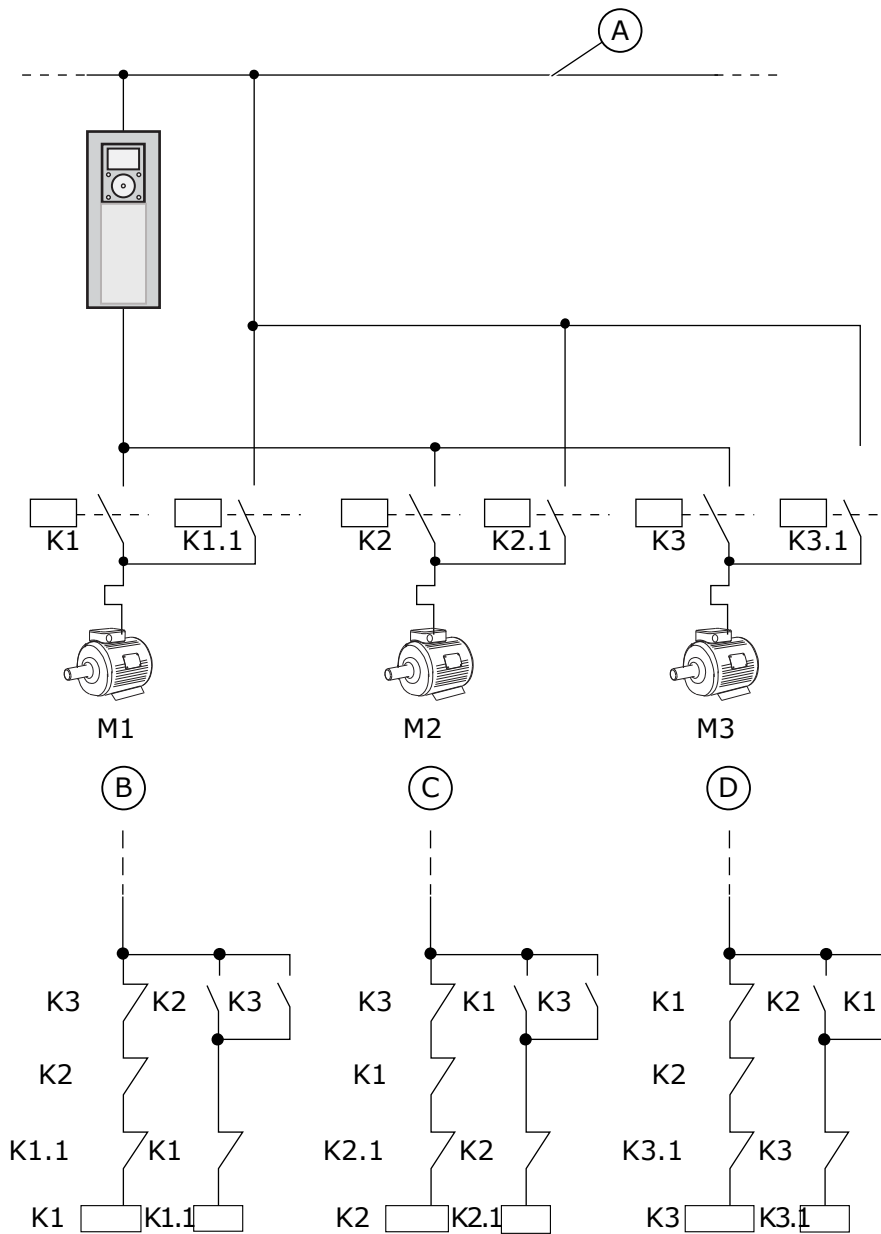

Illustration 85: Selection 1

A	Mains	C	Motor 2 control from relay
B	Motor 1 control from relay	D	Motor 3 control from relay

11.18.5 (ID 1027) Autochange

Location in the menu: P3.15.4

Use this parameter to enable or disable the rotation of the start sequence and the priority of motors.

Selection number	Selection name	Description
0	Disabled	In normal operation, the sequence of the motors is always 1, 2, 3, 4, 5. The sequence can change during the operation if interlocks are added or removed. After the drive stops, the sequence always changes back.
1	Enabled	The system changes the sequence at intervals to wear the motors equally. It is possible to adjust the intervals of the autochange.

To adjust the intervals of the autochange, use P3.15.5 Autochange Interval. It is possible to set the maximum number of motors that can operate with parameter Autochange: Motor Limit (P3.15.7). It is also possible to set the maximum frequency of the regulating motor (Autochange: Frequency Limit P3.15.6).

When the process is in the limits that are set with parameters P3.15.6 and P3.15.7, the autochange occurs. If process is not in these limits, the system waits until the process is in the limits, and do the autochange after that. This prevents sudden pressure drops during the autochange when a high capacity at a pump station is necessary.

Example

After an autochange, the first motor is put last. The other motors move up 1 position.

The start sequence of the motors: 1, 2, 3, 4, 5

--> Autochange -->

The start sequence of the motors: 2, 3, 4, 5, 1

--> Autochange -->

The start sequence of the motors: 3, 4, 5, 1, 2

11.18.6 (ID 1029) Autochange Interval

Location in the menu: **P3.15.5**

Use this parameter to adjust the autochange intervals. This parameter defines how often to rotate the starting order of the motors/pumps. The autochange is done when the number of running motors is below the autochange motor limit and the frequency is below the autochange freq limit. When the autochange interval has elapsed, the autochange occurs if the capacity is below the level set with P3.15.6 and P3.15.7.

11.18.7 (ID 1031) Autochange: Frequency Limit

Location in the menu: **P3.15.6**

Use this parameter to set the autochange frequency limit. An autochange is done when the autochange interval has elapsed, the number of running motors is less than autochange motor limit and the controlling drive is running below autochange frequency limit.

11.18.8 (ID 1030) Autochange: Motor Limit

Location in the menu: **P3.15.7**

Use this parameter to set the number of pumps used in Multi-pump function. An autochange is done when the autochange interval has elapsed, the number of running motors is less than autochange motor limit and the controlling drive is running below autochange frequency limit.

11.18.9 (ID 1097) Bandwidth

Location in the menu: **P3.15.8**

Use this parameter to set the bandwidth area around the PID setpoint for starting and stopping of the auxiliary motors. When the PID feedback value stays in the bandwidth area, the auxiliary motors do not start or stop. The value of this parameter is given as a percentage of the setpoint. For example, if setpoint = 5 bar, bandwidth = 10%. When the feedback value stays between 4.5 bar and 5.5 bar, the motor is not disconnected or removed.

11.18.10 (ID 1098) Bandwidth Delay

Location in the menu: **P3.15.9**

Use this parameter to set the duration before the auxiliary motors start or stop. When the PID feedback is outside the bandwidth area, the time that is set with this parameter must elapse before pumps can be added or removed.

11.18.11 (ID 426) Motor 1 Interlock

Location in the menu: **P3.15.10**

Use this parameter to select the digital input signal that is used as interlock signal for the multi-pump system.

11.18.12 Overpressure Supervision

11.18.12.1 (ID 1698) Enable Overpressure Supervision

Location in the menu: **P3.15.16.1**

Use this parameter to enable the Overpressure supervision. If the PID feedback becomes higher than the set overpressure limit, all auxiliary motors stop immediately. Only the regulating motor continues to operate.

It is possible to use the Overpressure supervision function in a Multi-pump system. For example, when closing the primary valve of the pump system quickly, the pressure in the pipe lines increases. The pressure can increase too quickly for the PID controller. To prevent that the pipes break, the overpressure supervision stops the auxiliary motors in the Multi-pump system.

The overpressure supervision monitors the feedback signal of the PID controller, that is, the pressure. If the signal becomes higher than the overpressure level, it stops all the auxiliary pumps immediately. Only the regulating motor continues to operate. When the pressure decreases, the system continues to operate, and connects the auxiliary motors again one at a time.

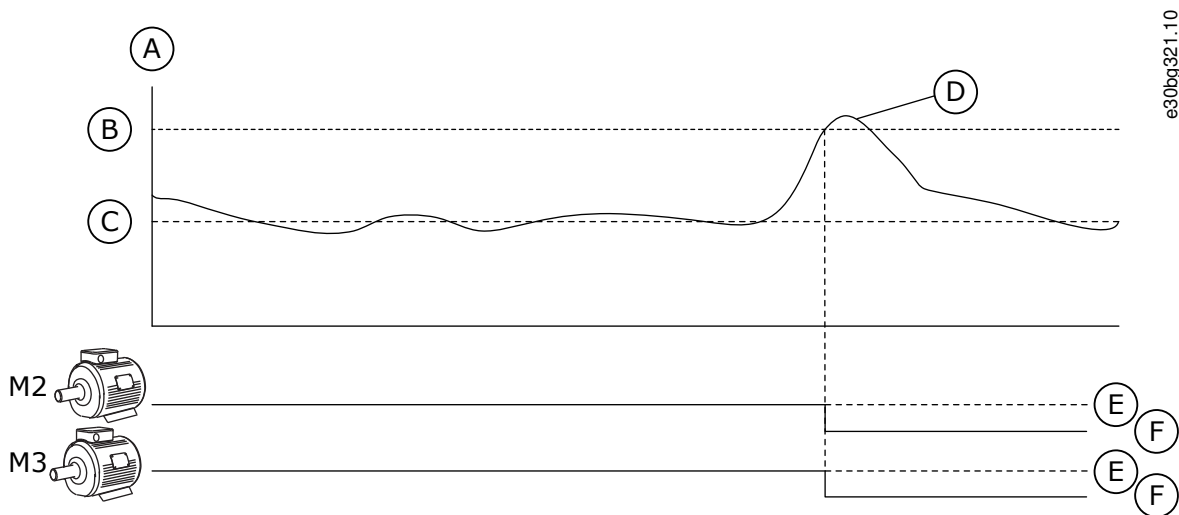

e30bg321.10

Illustration 86: The Overpressure Supervision Function

A	Pressure	D	PID Feedback (ID21)
B	Supervision Alarm Level (ID1699)	E	ON
C	PID Setpoint (ID167)	F	OFF

11.18.12.2 (ID 1699) Supervision Alarm Level

Location in the menu: **P3.15.16.2**

Use this parameter to set the overpressure limit for the Overpressure supervision. If the PID feedback becomes higher than the set overpressure limit, all auxiliary motors stop immediately. Only the regulating motor continues to operate.

11.19 Maintenance Counters

11.19.1 The Maintenance Counters

A maintenance counter tells that maintenance must be done. For example, it is necessary to replace a belt or to replace the oil in a gearbox. There are 2 different modes for the maintenance counters, hours, or revolutions*1000. The value of the counters increases only during the RUN status of the drive.

⚠ CAUTION ⚠

MAINTENANCE HAZARD

Only an approved electrician can do maintenance. There is a risk of injury.

- Do not do maintenance if you are not approved to do it.

N O T I C E

The revolutions mode uses motor speed, which is only an estimate. The drive measures the speed every second.

When the value of a counter is more than its limit, an alarm, or a fault shows. It is possible connect the alarm and fault signals to a digital output or a relay output.

When the maintenance is completed, reset the counter with a digital input or parameter P3.16.4 Counter 1 Reset.

11.19.2 (ID 1104) Counter 1 Mode

Location in the menu: **P3.16.1**

Use this parameter to enable the maintenance counter. A maintenance counter tells that the maintenance must be done when the counter value goes above the set limit.

11.19.3 (ID 1105) Counter 1 Alarm Limit

Location in the menu: **P3.16.2**

Use this parameter to set the alarm limit for the maintenance counter. When the value of the counter goes above this limit, a maintenance alarm occurs.

11.19.4 (ID 1106) Counter 1 Fault Limit

Location in the menu: **P3.16.3**

Use this parameter to set the fault limit for the maintenance counter. When the value of the counter goes above this limit, a maintenance fault occurs.

11.19.5 (ID 1107) Counter 1 Reset

Location in the menu: **P3.16.4**

Use this parameter to reset the maintenance counter.

11.19.6 (ID 490) Counter 1 DI Reset

Location in the menu: **P3.16.5**

Use this parameter to select the digital input that resets the value of the Maintenance Counter.

11.20 Fire Mode

11.20.1 The Fire Mode Function

When Fire mode is active, the drive resets all faults that occur and continues to operate at the same speed until it is not possible. The drive ignores all commands from the keypad, fieldbuses, and the PC tool. It only obeys the signals Fire Mode Activation, Fire Mode Reverse, Run Enable, Run Interlock 1, and Run Interlock 2 from I/O.

The Fire mode function has 2 modes, the Test mode, and the Enabled mode. To select a mode, write a password in parameter P3.17.1 (Fire Mode Password). In the Test mode, the drive does not automatically reset the faults, and the drive stops when a fault occurs.

It is also possible to configure Fire mode with the Fire mode wizard, which can be activated in the Quick Setup menu with parameter B1.1.4.

When the Fire mode function is activated, an alarm shows on the display.

N O T I C E

WARRANTY BECOMING VOID

The warranty is void if the Fire mode function is activated.

- Use Test mode to test the Fire mode function and the warranty stays valid.

11.20.2 (ID 1599) Fire Mode Password

Location in the menu: **P3.17.1**

Use this parameter to enable the fire mode function.

N O T I C E

All other fire mode parameters are locked when the fire mode is enabled and correct password is set in this parameter.

Selection number	Selection name	Description
1001	Enabled mode	The drive resets all the faults and continues to operate at the same speed until it is not possible.
1234	Test mode	The drive does not automatically reset the faults, and the drive stops when a fault occurs.

11.20.3 (ID 1617) Fire Mode Frequency Source

Location in the menu: **P3.17.2**

Use this parameter to select the frequency reference source when the fire mode is active. This parameter enables the selection of, for example, the AI1, or the PID controller as the reference source when operating the fire mode.

11.20.4 (ID 1598) Fire Mode Frequency

Location in the menu: **P3.17.3**

Use this parameter to set the frequency that is used when Fire mode is active. The drive uses this frequency when the value of parameter P3.17.2 Fire Mode Frequency Source is Fire Mode Frequency.

11.20.5 (ID 1596) Fire Mode Activation on Open

Location in the menu: **P3.17.4**

Use this parameter to select the digital input signal that activates the Fire Mode function. If this digital input signal is activated, an alarm shows on the display, and the warranty becomes void. The type of this digital input signal is NC (normally closed).

It is possible to try the Fire mode with the password that activates the Test mode. Then the warranty stays valid.

N O T I C E

If Fire mode is enabled, and the correct password is given to the parameter Fire Mode Password, all the Fire mode parameters become locked. To change the Fire mode parameters, change the value of P3.17.1 Fire Mode Password to 0 first.

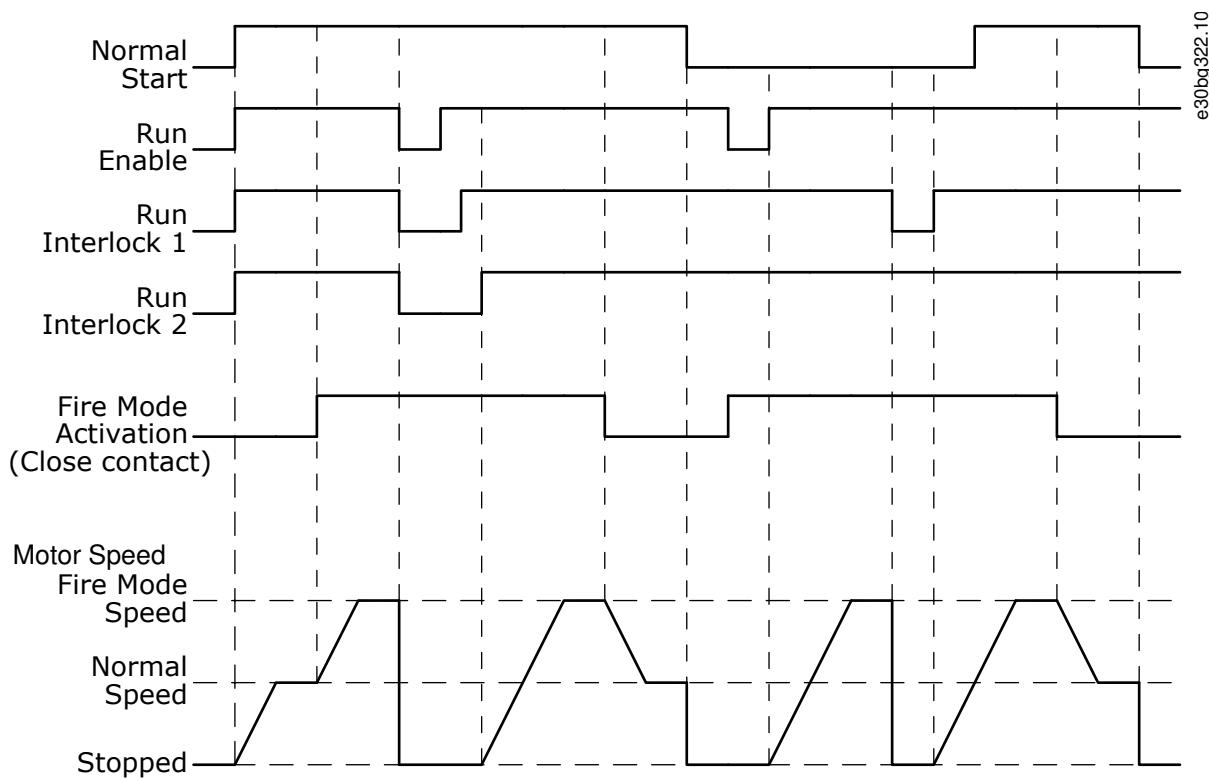

Illustration 87: The Fire Mode Function

11.20.6 (ID 1619) Fire Mode Activation on Close

Location in the menu: **P3.17.5**

Use this parameter to select the digital input signal that activates the Fire Mode function. The type of this digital input signal is NO (normally open). See the description for P3.17.4 Fire Mode Activation on Open.

11.20.7 (ID 1618) Fire Mode Reverse

Location in the menu: **P3.17.6**

Use this parameter to select the digital input signal that gives a command for reverse rotation direction during the Fire Mode. The parameter does not affect normal operation.

If it is necessary for the motor to operate always FORWARD or always REVERSE in Fire Mode, select the correct digital input.

DigIn Slot0.1 = always FORWARD

DigIn Slot0.2 = always REVERSE

11.20.8 (ID 1597) Fire Mode Status

Location in the menu: **V3.17.7**

This monitoring value shows the status of the fire mode function.

11.20.9 (ID 1679) Fire Mode Counter

Location in the menu: **V3.17.8**

This monitoring value shows the number of the fire mode activations.

The counter cannot be reset.

11.20.10 (ID 15580) Fire Mode Run Indication Current

Location in the menu: **P3.17.9**

Use this parameter to set the current limit for the run indication signal of the relay output.

This parameter only affects if the value "Run indication" is selected for a relay output and the fire mode is active. The "Run indication" relay output function tells quickly if current is supplied to the motor during a fire.

The value of this parameter is the percentage counted from the motor nominal current. If there is a fire and the current that is supplied to the motor is more than the nominal current times the value of this parameter, the relay output closes.

For example, if parameter Motor Nominal Current has the value 5 A, and 20% is set as the default value of this parameter, the relay output closes and Fire Mode activates when the output current goes to 1 A.

This parameter does not affect if the fire mode is not active. In normal operation, if "Run indication" is selected for a relay output, the result is the same as when "Run" is selected for the relay output.

11.21 Motor Preheat Function

11.21.1 (ID 1225) Motor Preheat Function

Location in the menu: **P3.18.1**

Use this parameter to enable or disable the Motor Preheat function. The motor preheat function keeps the drive and the motor warm during the STOP status. In the motor preheat, the system gives the motor a DC current. The motor preheat prevents, for example, condensation.

Selection number	Selection name	Description
0	Not used	The motor preheat function is disabled.
1	Always in Stop state	The motor preheat function is activated always when the drive is in the Stop state.
2	Controlled by digital input	The motor preheat function is activated by a digital input signal, when the drive is in the Stop state. It is possible to make the selection of the digital input for the activation with parameter P3.5.1.18.
3	Temperature limit (heat sink)	The motor preheat function is activated if the drive is in the Stop state, and the temperature of the heat sink of the drive goes below the temperature limit that was set with parameter P3.18.2.
4	Temperature limit (measured motor temperature)	The motor preheat function is activated if the drive is in the Stop state, and the measured motor temperature goes below the temperature limit that was set with parameter P3.18.2. It is possible to set the measurement signal of the motor temperature with parameter P3.18.5. NOTE! To use this operation mode, an option board for temperature measurement (for example OPTBH) is needed.

11.21.2 (ID 1226) Preheat Temperature Limit

Location in the menu: **P3.18.2**

Use this parameter to set the temperature limit of the Motor Preheat function. The motor preheat becomes active when the heat sink temperature or the measured motor temperature goes below this level, and when P3.18.1 is set to 3 or 4.

11.21.3 (ID 1227) Motor Preheat Current

Location in the menu: **P3.18.3**

Use this parameter to set the DC current of the Motor Preheat function. The DC current for the pre-heating of the motor and the drive in stop state. Activated as in P3.18.1.

11.21.4 (ID 1044) Motor Preheat ON

Location in the menu: **P3.18.4**

Use this parameter to select the digital input signal that activates Motor Preheat function. This parameter is used when P3.18.1 is set to 2. When the value for P3.18.1 is 2, it is also possible to connect time channels to this parameter.

11.21.5 (ID 1045) Preheat Motor Temperature

Location in the menu: **P3.18.5**

Use this parameter to select the temperature signal that is used to measure the motor temperature for motor preheat function.

N O T I C E

This parameter is not available if there is no option board for temperature measurement.

11.22 Drive Customizer

11.22.1 (ID 15001) Operation Mode

Location in the menu: **P3.19.1**

Use this parameter to select the operation mode of the drive customizer. When 'Programming' is selected, the execution of the block program is stopped and outputs of each function block are 0. When 'Execute Program' is selected, the block program is executed and block outputs are updated normally. The Drive Customizer cannot be configured when 'Execute Program' is selected.

Use the graphical Drive Customizer tool in VACON[®]Live.

11.23 Mechanical Brake

11.23.1 The Mechanical Brake Function

It is possible to monitor the mechanical brake with the monitoring value Application Status Word 1 in the monitoring group Extras and advanced.

The Mechanical brake control function controls an external mechanical brake with a digital output signal. The mechanical brake is opened/closed when the drive output frequency breaks the opening/closing limits.

11.23.2 (ID 1541) Brake Control

Location in the menu: **P3.20.1**

Use this parameter to set the operation mode of the mechanical brake. Mechanical brake status can be supervised via digital input when mode 2 is selected.

Selection number	Selection name	Description
0	Disabled	The mechanical brake control is not used.
1	Enabled	The mechanical brake control is used, but there is no supervision of the brake status.
2	Enabled with brake status supervision	The mechanical brake control is used, and a digital input signal monitors the brake status (P3.20.8).

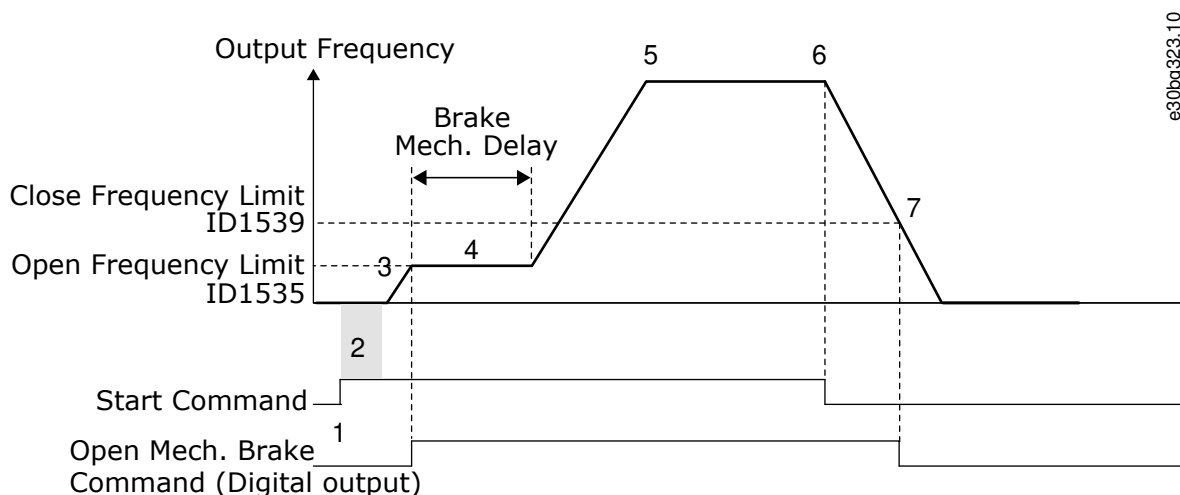

e30bg323.10

Illustration 88: The Mechanical Brake Function

<ol style="list-style-type: none"> 1. A Start command is given. 2. We recommend using start magnetization to build rotor flux fast and to decrease the time when the motor can produce nominal torque. 3. When the start magnetization time is over, the system lets the frequency reference go to the open frequency limit. 4. The mechanical brake opens. The frequency reference stays at the open frequency limit until the brake mechanical delay is over, and the correct brake feedback signal is received. 	<ol style="list-style-type: none"> 5. The output frequency of the drive follows the normal frequency reference. 6. A Stop command is given. 7. The mechanical brake becomes closed when the output frequency goes below the close frequency limit.
--	---

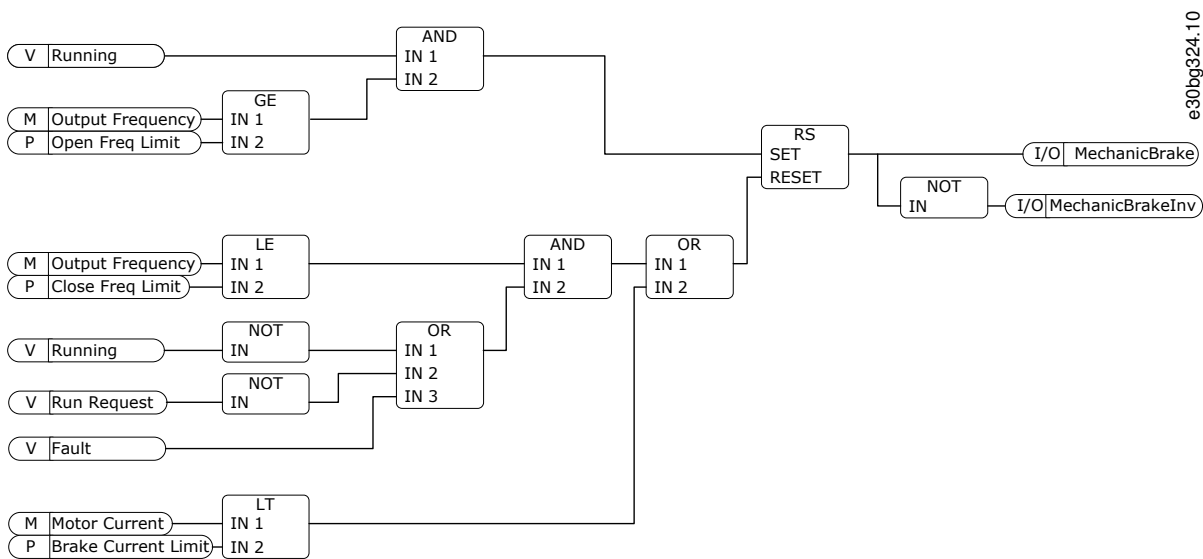

e30bg324.10

Illustration 89: The Mechanical Brake Opening Logic

11.23.3 (ID 1544) Brake Mechanical Delay

Location in the menu: **P3.20.2**

Use this parameter to set the mechanical delay that is necessary to open the brake. After the brake opening command is given, the speed stays at the value of the parameter P3.20.3 (Brake Opening Frequency Limit) until the brake mechanical delay is expired. Set the delay time to agree with the reaction time of the mechanical brake.

The Brake mechanical delay function is used to prevent current and/or torque spikes. It prevents the motor from operating at full speed against the brake. If P3.20.2 is used at the same time with P3.20.8, it is necessary to have the expired delay and the feedback signal to release the speed reference.

11.23.4 (ID 1535) Brake Opening Frequency Limit

Location in the menu: **P3.20.3**

Use this parameter to set the frequency limit for opening the mechanical brake. The value of the parameter P3.20.3 is the output frequency limit of the drive to open the mechanical brake. In open loop control, we recommend using a value that is equal to the nominal slip of the motor.

The output frequency of the drive stays at this level until the brake mechanical delay is expired, and the system receives the correct brake feedback signal.

11.23.5 (ID 1539) Brake Closing Frequency Limit

Location in the menu: **P3.20.4**

Use this parameter to set the frequency limit for closing the mechanical brake. The value of the parameter P3.20.4 is the output frequency limit of the drive to close the mechanical brake. The drive stops and the output frequency goes near 0. It is possible to use the parameter for the 2 directions, positive and negative.

11.23.6 (ID 1085) Brake Current Limit

Location in the menu: **P3.20.5**

Use this parameter to set the brake current limit. The Mechanical brake closes immediately if the motor current is below the limit set in parameter Brake Current Limit.

We recommend setting the value to approximately half of the magnetization current.

When the drive operates on the field weakening area, the brake current limit decreases automatically as a function of output frequency.

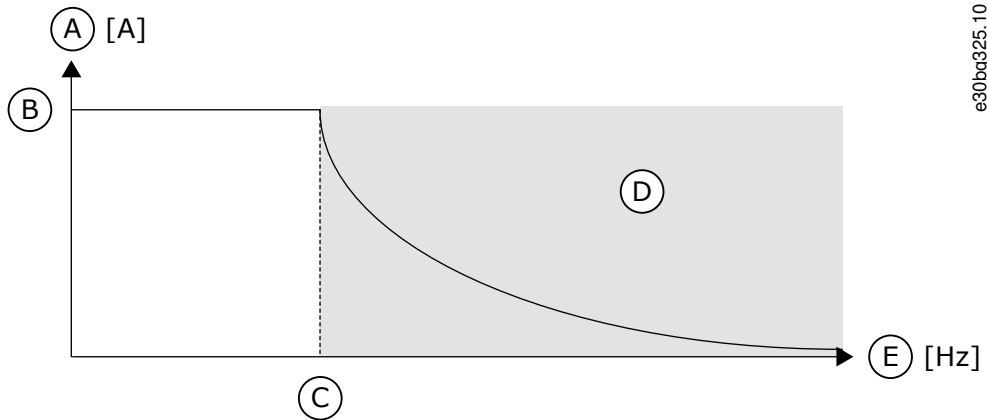

Illustration 90: Internal Reduction of the Brake Current Limit

A	Current	D	Field weakening area
B	Brake current limit (ID 1085)	E	Output frequency
C	Field weakening point (ID 602)		

11.23.7 (ID 352) Brake Fault Delay

Location in the menu: **P3.20.6**

Use this parameter to set the brake fault delay time. If the correct brake feedback signal is not received during this delay, a fault shows. This delay is only used if the value of P3.20.1 is set to 2.

11.23.8 (ID 1316) Response to Brake Fault

Location in the menu: **P3.20.7**

Use this parameter to set the response type to a brake fault.

11.23.9 (ID 1210) Brake Feedback

Location in the menu: **P3.20.8 (P3.5.1.44)**

Use this parameter to set the brake status feedback signal from mechanical brake. The Brake feedback signal is used if the value for parameter P3.20.1 is Enabled with brake status supervision.

Connect this digital input signal to an auxiliary contact of the mechanical brake.

- The contact is open = the mechanical brake is closed.
- The contact is closed = the mechanical brake is open.

If the brake opening command is given, but the contact of the brake feedback signal does not close in given time, a mechanical brake fault shows (fault code 58).

11.24 Pump Control

11.24.1 Auto-Cleaning

Use the Auto-cleaning function to remove dirt or other material from the pump impeller. It is also possible to use the function to clear a blocked pipe or valve. It is possible to use the auto-cleaning, for example, in wastewater systems to keep the performance of the pump satisfactory.

NOTICE

This function does not respect the minimum frequency. The auto-cleaning sequence can also operate below the given minimum frequency.

11.24.1.1 (ID 1714) Cleaning Function

Location in the menu: **P3.21.1.1**

Use this parameter to enable the Auto-cleaning function. If the parameter Cleaning Function is enabled, the auto-cleaning starts, and activates the digital input signal in parameter P3.21.1.2.

11.24.1.2 (ID 1715) Cleaning Activation

Location in the menu: **P3.21.1.2**

Use this parameter to select the digital input signal that starts the Auto-cleaning sequence. The auto-cleaning stops if the activation signal is removed before the sequence is complete.

NOTICE

If the input is activated, the drive starts.

11.24.1.3 (ID 1716) Cleaning Cycles

Location in the menu: **P3.21.1.3**

Use this parameter to set the number of forward or reverse cleaning cycles.

11.24.1.4 (ID 1717) Clean Forward Frequency

Location in the menu: **P3.21.1.4**

Use this parameter to set the frequency reference of the drive for the forward direction in the Auto-cleaning cycle. Set the frequency and time of the cleaning cycle with the parameters P3.21.1.4, P3.21.1.5, P3.21.1.6, and P3.21.1.7.

11.24.1.5 (ID 1718) Clean Forward Time

Location in the menu: **P3.21.1.5**

Use this parameter to set the operation time for the forward direction frequency in the Autocleaning cycle. See parameter [11.24.1.4 \(ID 1717\) Clean Forward Frequency](#).

11.24.1.6 (ID 1719) Clean Reverse Frequency

Location in the menu: **P3.21.1.6**

Use this parameter to set the frequency reference of the drive for the reverse direction in the Auto-cleaning cycle. See parameter [11.24.1.4 \(ID 1717\) Clean Forward Frequency](#).

11.24.1.7 (ID 1720) Clean Reverse Time

Location in the menu: **P3.21.1.7**

Use this parameter to set the operation time for the reverse direction frequency in the Autocleaning cycle. See parameter [11.24.1.4 \(ID 1717\) Clean Forward Frequency](#).

11.24.1.8 (ID 1721) Cleaning Acceleration Time

Location in the menu: **P3.21.1.8**

Use this parameter to set the motor acceleration time when the Auto-cleaning is active. It is possible to set acceleration and deceleration ramps for the Auto-cleaning function with parameters P3.21.1.8 and P3.21.1.9.

11.24.1.9 (ID 1722) Cleaning Deceleration Time

Location in the menu: **P3.21.1.9**

Use this parameter to set the motor deceleration time when the Auto-cleaning is active. It is possible to set acceleration and deceleration ramps for the Auto-cleaning function with parameters P3.21.1.8 and P3.21.1.9.

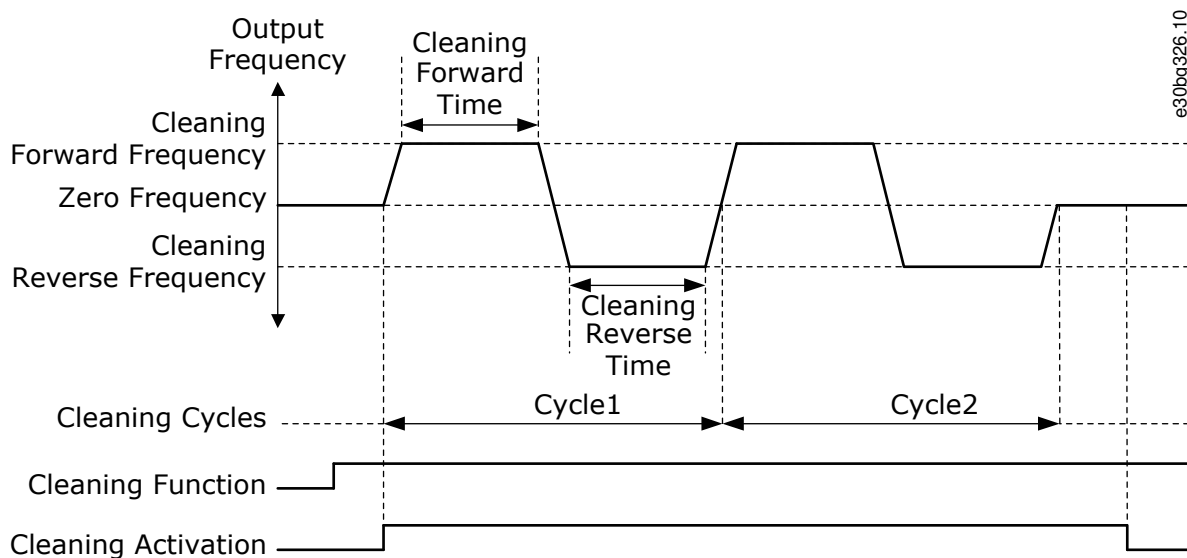

Illustration 91: The Auto-cleaning Function

11.24.2 Jockey Pump

11.24.2.1 (ID 1674) Jockey Function

Location in the menu: P3.21.2.1

Use this parameter to control the Jockey pump function. A Jockey pump is a smaller pump that keeps the pressure in the pipeline, when the main pump is in the sleep mode. It can occur, for example, in the night.

The Jockey pump function controls a jockey pump with a digital output signal. A jockey pump can be used if a PID controller is used to control the main pump. The function has 3 operation modes.

Selection number	Selection name	Description
0	Not used	
1	PID sleep	The jockey pump starts when the PID Sleep of the main pump activates. The jockey pump stops when the main pump wakes up from the sleep mode.
2	PID sleep (level)	The jockey pump starts when the PID Sleep activates, and the PID feedback signal is less than the level set by parameter P3.21.2.2. The jockey pump stops when the PID feedback signal is more than the level set in parameter P3.21.2.3 or the main pump wakes up from the sleep mode.

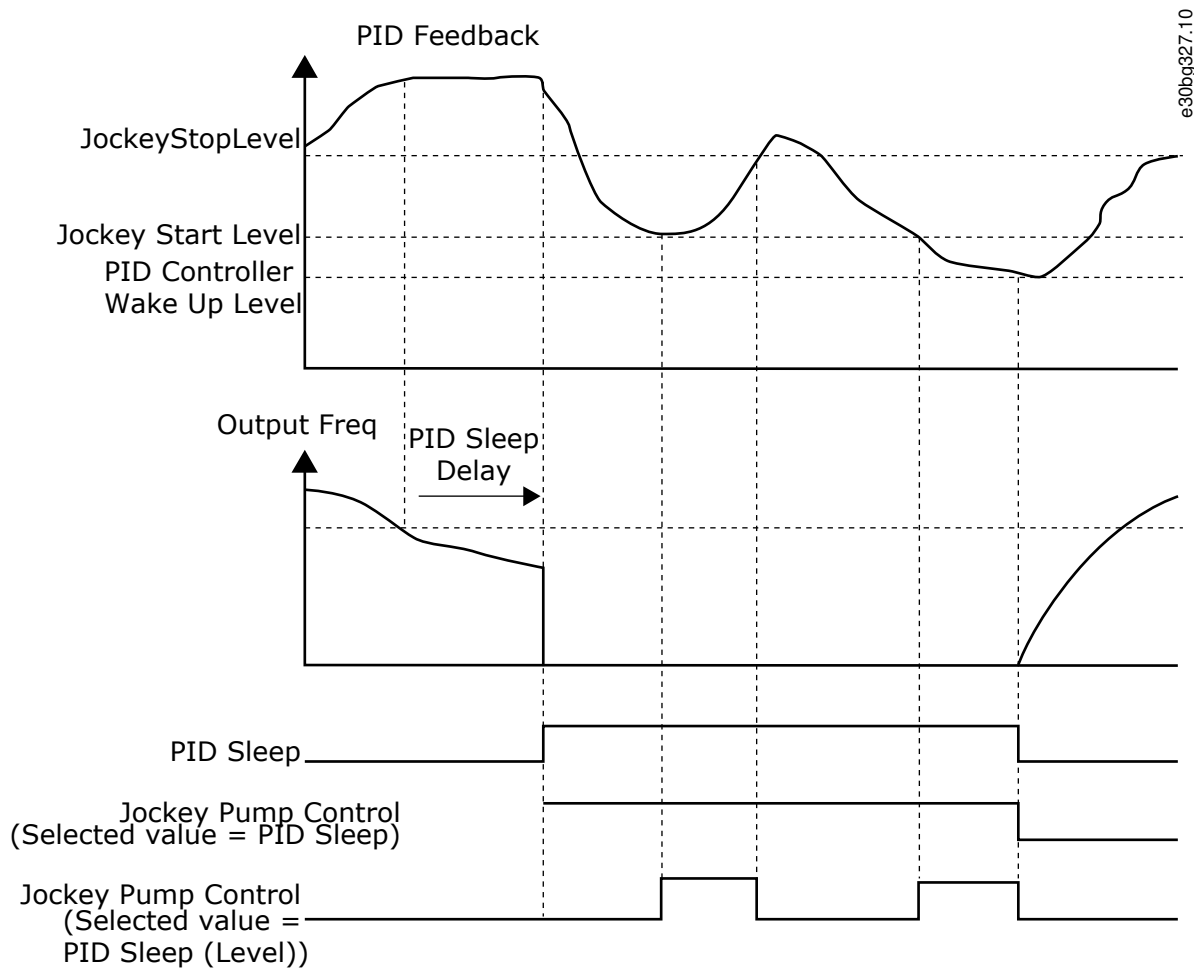

Illustration 92: The Jockey Pump Function

11.24.2.2 (ID 1675) Jockey Start Level

Location in the menu: P3.21.2.2

Use this parameter to set the level of the PID feedback signal at which the jockey pump starts when the main pump is in the sleep state. The jockey pump starts when PID Sleep is active and the PID feedback signal goes below the level set in this parameter.

This parameter is used only if P3.21.2.1 = 2 PID sleep (level).

11.24.2.3 (ID 1676) Jockey Stop Level

Location in the menu: P3.21.2.3

Use this parameter to set the level of the PID feedback signal at which the jockey pump stops when the main pump is in the sleep state.

The jockey pump stops when PID Sleep is active and the PID feedback signal goes above the level set in this parameter, or when the PID controller wakes up from sleep mode.

This parameter is used only if P3.21.2.1 = 2 PID sleep (level).

11.24.3 Priming Pump

A priming pump is a smaller pump that primes the inlet of the main pump to prevent suction of air.

The priming pump function controls a priming pump with a digital output signal. It is possible to set a delay to start the priming pump before the main pump starts. The priming pump operates continuously while the main pump operates. If the main pump goes into sleep mode, the priming pump also stops for that time. When waking up from sleep mode, the main pump, and the priming pump start simultaneously.

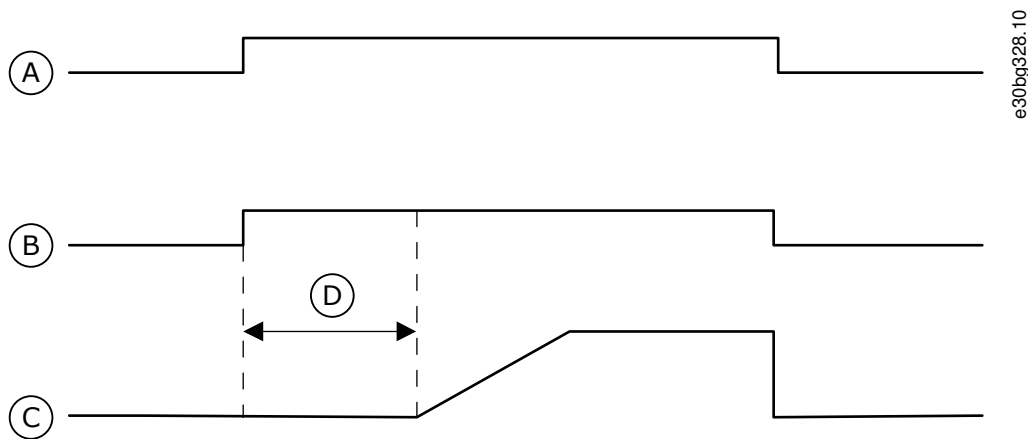

Illustration 93: The Priming Pump Function

A	Start Command (Main Pump)	C	Output Frequency (Main Pump)
B	Priming Pump Control (Digital Output Signal)	D	Priming Time

11.24.3.1 (ID 1677) Priming Function

Location in the menu: **P3.21.3.1**

Use this parameter to enable the Priming pump function. A priming pump is a smaller pump that primes the inlet of the main pump to prevent the suction of air. The priming pump function controls a priming pump with a relay output signal.

11.24.3.2 (ID 1678) Priming Time

Location in the menu: **P3.21.3.2**

Use this parameter to set the time that the priming pump operates before the main pump starts.

11.25 Advanced Harmonic Filter

11.25.1 (ID 15510) Capacitor Disconnection Limit

Menu location: **P3.22.1**.

Use this parameter to set the disconnection limit for the advanced harmonic filter. The value is in percentage of the drive nominal power.

11.25.2 (ID 15511) Capacitor Disconnection Hysteresis

Location in the menu: **P3.22.2**

Use this parameter to set the disconnection hysteresis for the advanced harmonic filter. The value is in percentage of the drive nominal power.

11.25.3 (ID 15513) AHF Over Temperature

- Location in the menu: **P3.5.1.52** (In I/O Configuration parameter menu)
- Location in the menu: **P3.22.3** (In Advanced Harmonic Filter parameter menu)

Use this parameter to set the digital input signal that activates AHF Over Temp (fault ID 1118).

11.25.4 (ID 15512) AHF Fault Response

Location in the menu: **P3.22.4**

Use this parameter to select the response of the AC drive to an AHF Over Temp fault.

11.26 Condition-based Monitoring

11.26.1 Introduction to Condition-based Monitoring

Condition-based monitoring in VACON® 100 drives is launched as a factory-flashed licensed firmware, embedded within the drive.

Benefits of installing the condition-based monitoring firmware are as follows:

- Reduces unexpected downtime.
- Optimizes drive or motor working conditions.
- Eliminates unexpected halts in production.

Condition-based monitoring enables regularly checks of the condition and performance of the machine when the drive is in service and detects mechanical, motor, or application failures in advance. Corrective actions can be performed before the process or application is impacted. Alarm/fault or warnings are triggered in the drive to notify customers or service technicians. Some of the corrective actions include replacement of faulty motors or bearings and ensuring the motor is running within optimal conditions.

Following are the monitoring capabilities introduced:

- **Motor stator winding monitoring:** During monitoring, inter-turn short circuit or unbalance in the motor winding is detected in advance. Damage caused by motor stator winding isolation occurs over time. When more winding turns are impacted, the over-current protection is activated due to extensive heating and stops the motor.
- **Vibration monitoring:** With the help of external sensors, the drive can monitor vibration levels in a motor. Vibrations affect motor control and can lead to motor failure. During monitoring, early detection of motor misalignment is detected and wear and tear of mechanical parts are identified earlier.
NOTE! ISO 10816 standard provides guidance for evaluating vibration severity for machines operating within 10–200 Hz of frequency range. The standard must be complied with before commissioning of vibration monitoring function.
- **Load envelope:** Mechanical load of an application is monitored by comparing current load curve with expected load curve based on data gathered during commissioning. During monitoring, overload and underload deviations which occur in applications are detected.

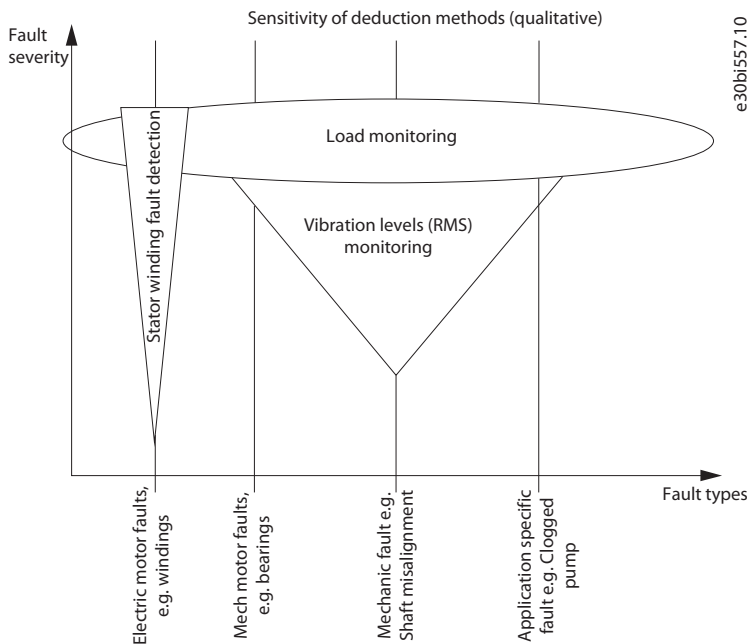

Illustration 94: Condition-based Monitoring

11.26.1.1 Stages of Condition-based Monitoring

The following figure describes the different stages of Condition-based Monitoring.

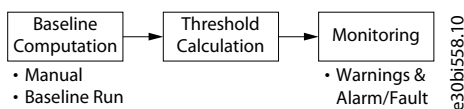

Illustration 95: Stages of Condition-based Monitoring

- **Baseline Computation:** During the initial stage, baselines for different types of condition-based monitoring are computed, based on the type of baseline mode selected.
- **Threshold Calculation:** Once the baseline is computed, the thresholds for warnings (stage 1 and stage 2) and alarm/fault are computed based on the warning or alarm/fault mode. The threshold and mode are set via parameters.
- **Monitoring:** After the thresholds are calculated, condition-based monitoring begins. Alarm/fault and warnings are triggered during deviations to notify customers.

To begin condition-based monitoring, a baseline must be generated. During this activity, the system captures motor stator winding speed points for each baseline. Define the duration, minimum and maximum speed for baseline generation. During baseline generation, 10 speed points are captured. The first and last speed point is captured based on the defined minimum and maximum speed respectively.

When speed points are not captured properly, baseline generation fails, then a new baseline has to be generated. The baseline serves as a reference for threshold limits. Using parameters, select the type of baseline measurement.

- **Baseline Run:** The drive controls the motor speed and monitors required values to derive a baseline. The drive creates a speed profile for baseline measurement. The drive interrupts the application during baseline run to operate on the speed profile created for baseline measurement. The duration for baseline calculation can be specified. Baseline measurements can copy to other drive or return to same drive after factory reset.
- **Manual Run:** The measurement points can be manually configured directly through modified parameters. Manual run can be made before or after baseline run.

11.26.2 (ID 3501) BaselineRun Start

Location in the menu: **P3.23.2.1**

Use this parameter to activate baseline run.

Baseline run is made before normal operation. Idea is to compare actual measurements with measurements taken when the system was in healthy/normal condition. The measurements from healthy condition are called "baseline".

In baseline run, the measurements of the motor current unbalance for stator winding, vibration, and motor torque are collected.

The baseline run goes through 10 frequency points including 10 steady and 9 ramp states. It collects the minimum, maximum, mean, and standard deviation values, and stores the statistical baseline data in arrays. Normal start command is required after baseline run start.

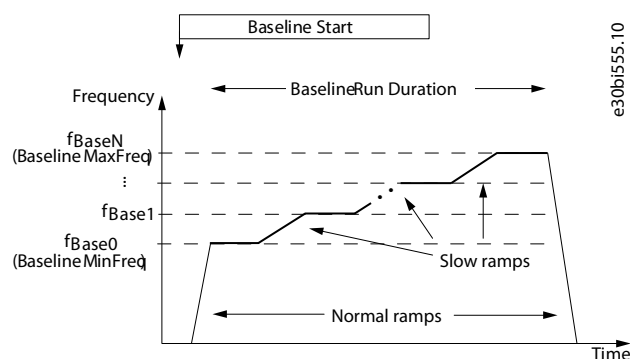

Illustration 96: BaselineRun Start

11.26.3 (ID 3502) BaselineRun MinFreq

Location in the menu: **P3.23.2.2**

Use this parameter to set frequency point where baseline run is started.

11.26.4 (ID 3503) BaselineRun MaxFreq

Location in the menu: **P3.23.2.3**

Use this parameter to set frequency point where baseline run is ended.

11.26.5 (ID 3504) BaselineRun Duration

Location in the menu: **P3.23.2.4**

Use this parameter to set the duration of the baseline run.

11.26.6 Manual Run

Before or after baseline run, each measurement point can be modified by parameter. One array includes 10 points in steady state and 9 points in ramp state.

11.26.6.1 (ID 3506) Modified Array

Location in the menu: **P3.23.2.5**

Use this parameter to select a modified array.

11.26.6.2 (ID 3507) Modified Point

Location in the menu: **P3.23.2.6**

Use this parameter to select which measurement point to modify in the array. Steady array includes 10 points and ramp array includes 9 points. First point has value 0.

11.26.6.3 (ID 3508) Modified Value

Location in the menu: **P3.23.2.7**

Use this parameter to give new value to the point selected with *ID 3507*.

11.26.6.4 (ID 3505) Modified Activation

Location in the menu: **P3.23.2.8**

Before or after the baseline run, each measurement point can be modified. Use this parameter to activate the *Modified value (ID 3508)* of the *Modified point (ID 3507)*.

11.26.6.5 (ID 3509) Baseline Data Selector

Location in the menu: **P3.23.2.9**

Use this parameter to select which array points can be monitored in monitor group *M2.16.1 Baseline data*.

11.26.6.6 (ID 3540) Condition-based Monitoring Fault Mode

Location in the menu: **P3.23.1**

Use this parameter to set the response of the drive to Exception.

Selection number	Selection name	Description
0	No Action	
1	Warnings	Warning levels S1 and S2 are used.
2	Fault + Warnings	Warning S1, warning S2 and alarm/fault levels are used.

11.26.7 Stator Winding Monitoring

For stator winding monitoring, the motor currents are being evaluated for evolving unbalances. For this purpose, current unbalance is computed and monitored. If there are the unbalanced grid voltages, a resonance-like oscillation can occur if the motor frequency matches the grid frequency.

11.26.7.1 (ID 1913) Line Freq

Location in the menu: **P3.23.3.1**

Use this parameter to set the grid Nominal Frequency.

11.26.7.2 (ID 1914) Line Freq Hysteresis

Location in the menu: **P3.23.3.2**

Use this parameter to set the hysteresis of the grid Nominal Frequency. Stator winding monitoring is not used in the hysteresis area.

11.26.8 Threshold Value

The several statistical data points (mean, minimum, maximum, and standard) from the baseline model can be combined one threshold value.

Threshold value = MeanFactor * mean + MinFactor * min + MaxFactor * max + StdFactor * stddev

11.26.8.1 (ID 3511) Current Mean Factor

Location in the menu: **P3.23.3.3.1.1**

Use this parameter to set the mean factor in the threshold value. If the threshold value is zero, the mean factor is not used.

11.26.8.2 (ID 3512) Current Min Factor

Location in the menu: **P3.23.3.3.1.2**

Use this parameter to set min factor in the threshold value. If the threshold value is zero, the min factor is not used.

11.26.8.3 (ID 3513) Current Max Factor

Location in the menu: **P3.23.3.3.1.3**

Use this parameter to set the max factor in the threshold value. If the threshold value is zero, the max factor is not used.

11.26.8.4 (ID 3514) Current Std Factor

Location in the menu: **P3.23.3.3.1.4**

Use this parameter to set the std factor in the threshold value. If the threshold value is zero, the std factor is not used.

11.26.8.5 (ID 3515) Current Interpolation Type

Location in the menu: **P3.23.3.3.1.5**

Use this parameter to select interpolation type for the notification threshold values across frequency points.

11.26.8.6 (ID 3550) Vibration Mean Factor

Location in the menu: **P3.23.4.2.1**

Use this parameter to set the mean factor in the threshold value. If the threshold value is zero, the mean factor is not used.

11.26.8.7 (ID 3551) Vibration Min Factor

Location in the menu: **P3.23.4.2.2**

Use this parameter to set the min factor in the threshold value. If the threshold value is zero, the min factor is not used.

11.26.8.8 (ID 3552) Vibration Max Factor

Location in the menu: **P3.23.4.2.3**

Use this parameter to set the max factor in the threshold value. If the threshold value is zero, the max factor is not used.

11.26.8.9 (ID 3553) Vibration Std Factor

Location in the menu: **P3.23.4.2.4**

Use this parameter to set the std factor in the threshold value. If the threshold value is zero, the std factor is not used.

11.26.8.10 (ID 3554) Vibration Interpolation Type

Location in the menu: **P3.23.4.2.5**

Use this parameter to select interpolation type for the notification threshold values across frequency points.

11.26.8.11 (ID 3567) Load Mean Factor

Location in the menu: **P3.23.5.1.1**

Use this parameter to set the mean factor in the threshold value. If the threshold value is zero, the mean factor is not used.

11.26.8.12 (ID 3568) Load Min Factor

Location in the menu: **P3.23.5.1.2**

Use this parameter to set the min factor in the threshold value. If the threshold value is zero, the min factor is not used.

11.26.8.13 (ID 3569) Load Max Factor

Location in the menu: **P3.23.5.1.3**

Use this parameter to set the max factor in the threshold value. If the threshold value is zero, the max factor is not used.

11.26.8.14 (ID 3570) Load Std Factor

Location in the menu: **P3.23.5.1.4**

Use this parameter to set the std factor in the threshold value. If the threshold value is zero, the std factor is not used.

11.26.8.15 (ID 3571) Load Interpolation Type

Location in the menu: **P3.23.5.1.5**

Use this parameter to select interpolation type for the notification threshold values across frequency points.

11.26.9 Warning and Alarm/Fault Stages

Each of the three detection levels (Warning S1, Warning S2, Alarm/Fault) has a configurable timer associated that delays the response. The timing principle is like an electrical fuse where the response time is long for low levels and it is short for high levels.

11.26.9.1 (ID 3516) Current Warning S1 Mode

Location in the menu: **P3.23.3.3.2.1**

Use this parameter to select the warning S1 mode which is used for calculating warning S1 notification threshold.

Selection number	Selection name	Description
0	Absolute	Absolute value is considered as threshold
1	Offset	Calculates threshold as sum of the computed baseline data and the offset values
2	Factor	Calculates threshold as baseline data factor

11.26.9.2 (ID 3517) Current Warning S1 High

Location in the menu: **P3.23.3.3.2.2**

Use this parameter to set the threshold value for computing the warning 1 high notification threshold. Threshold value range varies based on warning mode selection. This limit is not used when value is zero.

11.26.9.3 (ID 3518) Current Warning S1 Delay

Location in the menu: **P3.23.3.3.2.3**

Use this parameter to define how long time the actual value must be above the warning S1 notification level to trigger the warning S1. This level is not used when delay is zero.

11.26.9.4 (ID 3519) Current Warning S2 Mode

Location in the menu: **P3.23.3.3.2.4**

Use this parameter to select the warning S2 mode which is used for calculating warning S2 notification threshold.

Selection number	Selection name	Description
0	Absolute	Absolute value is considered as threshold
1	Offset	Calculates threshold as sum of the computed baseline data and the offset values
2	Factor	Calculates threshold as baseline data factor

11.26.9.5 (ID 3520) Current Warning S2 High

Location in the menu: **P3.23.3.3.2.5**

Use this parameter to set the threshold value for computing the warning 2 high notification threshold. Threshold value range varies based on warning mode selection. This limit is not used when value is zero.

11.26.9.6 (ID 3521) Current Warning S2 Delay

Location in the menu: **P3.23.3.3.2.6**

Use this parameter to define how long time the actual value must be above the warning S2 notification level to trigger the warning S2. This level is not used when delay is zero.

11.26.9.7 (ID 3522) Current Alarm/Fault Mode

Location in the menu: **P3.23.3.3.2.7**

Use this parameter to select the alarm/fault mode which is used for calculating alarm/fault notification threshold.

Selection number	Selection name	Description
0	Absolute	Absolute value is considered as threshold
1	Offset	Calculates threshold as sum of the computed baseline data and the offset values
2	Factor	Calculates threshold as baseline data factor

11.26.9.8 (ID 3523) Current Alarm/Fault High

Location in the menu: **P3.23.3.3.2.8**

Use this parameter to set the threshold value for computing the alarm/fault high notification threshold. Threshold value range varies based on alarm/fault mode selection. This limit is not used when value is zero.

11.26.9.9 (ID 3524) Current Alarm/Fault Delay

Location in the menu: **P3.23.3.3.2.9**

Use this parameter to define how long time the actual value must be above the alarm/fault notification level to trigger the alarm/fault. This level is not used when delay is zero.

11.26.9.10 (ID 3541) Current Warning S1 Counter

Location in the menu: **P3.23.3.3.3.1**

Use this parameter to set warning S1 counter value.

11.26.9.11 (ID 3542) Current Warning S2 Counter

Location in the menu: **P3.23.3.3.3.2**

Use this parameter to set warning S2 counter value.

11.26.9.12 (ID 3543) Current Alarm/Fault Counter

Location in the menu: **P3.23.3.3.3.3**

Use this parameter to set alarm/fault counter value.

11.26.9.13 (ID 3549) Stop Counter Delay

Use this parameter to set stop counter. The counter is stopped if threshold value is outside of the limit below this time.

11.26.9.14 (ID 3555) Vibration Warning S1 Mode

Location in the menu: **P3.23.4.3.1**

Use this parameter to select the warning S1 mode which is used for calculating warning S1 notification threshold.

Selection number	Selection name	Description
0	Absolute	Absolute value is considered as threshold
1	Offset	Calculates threshold as sum of the computed baseline data and the offset values
2	Factor	Calculates threshold as baseline data factor

11.26.9.15 (ID 3556) Vibration Warning S1 High

Location in the menu: **P3.23.4.3.2**

Use this parameter to set the threshold value for computing the warning 1 high notification threshold. Threshold value range varies based on warning mode selection. This limit is not used when value is zero.

11.26.9.16 (ID 3557) Vibration Warning S1 Delay

Location in the menu: **P3.23.4.3.3**

Use this parameter to define how long time the actual value must be above the warning S1 notification level to trigger the warning S1. This level is not used when delay is zero.

11.26.9.17 (ID 3558) Vibration Warning S2 Mode

Location in the menu: **P3.23.4.3.4**

Use this parameter to select the warning S2 mode which is used for calculating warning S2 notification threshold.

Selection number	Selection name	Description
0	Absolute	Absolute value is considered as threshold
1	Offset	Calculates threshold as sum of the computed baseline data and the offset values
2	Factor	Calculates threshold as baseline data factor

11.26.9.18 (ID 3559) Vibration Warning S2 High

Location in the menu: **P3.23.4.3.5**

Use this parameter to set the threshold value for computing the warning 2 high notification threshold. Threshold value range varies based on warning mode selection. This limit is not used when value is zero.

11.26.9.19 (ID 3560) Vibration Warning S2 Delay

Location in the menu: **P3.23.4.3.6**

Use this parameter to define how long time the actual value must be above the warning S2 notification level to trigger the warning S2. This level is not used when delay is zero.

11.26.9.20 (ID 3561) Vibration Alarm/Fault Mode

Location in the menu: **P3.23.4.3.7**

Use this parameter to select the alarm/fault mode which is used for calculating alarm/fault notification threshold.

Selection number	Selection name	Description
0	Absolute	Absolute value is considered as threshold
1	Offset	Calculates threshold as sum of the computed baseline data and the offset values
2	Factor	Calculates threshold as baseline data factor

11.26.9.21 (ID 3562) Vibration Alarm/Fault High

Location in the menu: **P3.23.4.3.8**

Use this parameter to set the threshold value for computing the alarm/fault high notification threshold. Threshold value range varies based on warning mode selection. This limit is not used when value is zero.

11.26.9.22 (ID 3563) Vibration Alarm/Fault Delay

Location in the menu: **P3.23.4.3.9**

Use this parameter to define how long time the actual value must be above the alarm/fault notification level to trigger the alarm/fault. This level is not used when delay is zero.

11.26.9.23 (ID 3564) Vibration Warning S1 Counter

Location in the menu: **P3.23.4.4.1**

Use this parameter to set warning S1 counter value.

11.26.9.24 (ID 3565) Vibration Warning S2 Counter

Location in the menu: **P3.23.4.4.2**

Use this parameter to set warning S2 counter value.

11.26.9.25 (ID 3566) Vibration Alarm/Fault Counter

Location in the menu: **P3.23.4.4.3**

Use this parameter to set alarm/fault counter value.

11.26.9.26 (ID 3572) Load Warning S1 Mode

Location in the menu: **P3.23.5.2.1**

Use this parameter to select the warning S1 mode which is used for calculating warning S1 notification threshold.

Selection number	Selection name	Description
0	Absolute	Absolute value is considered as threshold
1	Offset	Calculates threshold as sum of the computed baseline data and the offset values
2	Factor	Calculates threshold as baseline data factor

11.26.9.27 (ID 3573) Load Warning S1 High

Location in the menu: **P3.23.5.2.3**

Use this parameter to set the threshold value for computing the warning 1 high notification threshold. Threshold value range varies based on warning mode selection. This limit is not used when value is zero.

11.26.9.28 (ID 3574) Load Warning S1 Delay

Location in the menu: **P3.23.5.2.4**

Use this parameter to define how long time the actual value must be above the warning S1 notification level to trigger the warning S1. This level is not used when delay is zero.

11.26.9.29 (ID 3575) Load Warning S2 Mode

Location in the menu: **P3.23.5.2.5**

Use this parameter to select the warning S2 mode which is used for calculating warning S2 notification threshold.

Selection number	Selection name	Description
0	Absolute	Absolute value is considered as threshold
1	Offset	Calculates threshold as sum of the computed baseline data and the offset values
2	Factor	Calculates threshold as baseline data factor

11.26.9.30 (ID 3576) Load Warning S2 High

Location in the menu: **P3.23.5.2.7**

Use this parameter to set the threshold value for computing the warning 2 high notification threshold. Threshold value range varies based on warning mode selection. This limit is not used when value is zero.

11.26.9.31 (ID 3577) Load Warning S2 Delay

Location in the menu: **P3.23.5.2.8**

Use this parameter to define how long time the actual value must be above the warning S2 notification level to trigger the warning S2. This level is not used when delay is zero.

11.26.9.32 (ID 3578) Load Alarm/Fault Mode

Location in the menu: **P3.23.5.2.9**

Use this parameter to select the alarm/fault mode which is used for calculating alarm/fault notification threshold.

Selection number	Selection name	Description
0	Absolute	Absolute value is considered as threshold
1	Offset	Calculates threshold as sum of the computed baseline data and the offset values
2	Factor	Calculates threshold as baseline data factor

11.26.9.33 (ID 3579) Load Alarm/Fault High

Location in the menu: **P3.23.5.2.11**

Use this parameter to set the threshold value for computing the alarm/fault high notification threshold. Threshold value range varies based on warning mode selection. This limit is not used when value is zero.

11.26.9.34 (ID 3580) Load Alarm/Fault Delay

Location in the menu: **P3.23.5.2.12**

Use this parameter to define how long time the actual value must be above the alarm/fault notification level to trigger the alarm/fault. This level is not used when delay is zero.

11.26.9.35 (ID 3581) Load Warning S1 Counter

Location in the menu: **P3.23.5.3.1**

Use this parameter to set warning S1 counter value.

11.26.9.36 (ID 3582) Load Warning S2 Counter

Location in the menu: **P3.23.5.3.2**

Use this parameter to set warning S2 counter value.

11.26.9.37 (ID 3583) Load Alarm/Fault Counter

Location in the menu: **P3.23.5.3.3**

Use this parameter to set alarm/fault counter value.

11.26.9.38 (ID 3584) Load Warning S1 Low

Location in the menu: **P3.23.5.2.2**

Use this parameter to set the threshold value for computing the warning 1 low notification threshold. Threshold value range varies based on warning mode selection. This limit is not used when value is zero.

11.26.9.39 (ID 3585) Load Warning S2 Low

Location in the menu: **P3.23.5.2.6**

Use this parameter to set the threshold value for computing the warning 2 low notification threshold. Threshold value range varies based on warning mode selection. This limit is not used when value is zero.

11.26.9.40 (ID 3586) Load Alarm/Fault Low

Location in the menu: **P3.23.5.2.10**

Use this parameter to set the threshold value for computing the alarm/fault low notification threshold. Threshold value range varies based on warning mode selection. This limit is not used when value is zero.

11.26.10 (ID 3587) Vibration Input

Location in the menu: **P3.23.4.1**

Use this parameter to select the analog input to vibration.

11.27 Default Values of Parameters in the Different Applications

Table 134: Default Values of Parameters of Group 3.2

Index	Parameter	Standard application	Local/Remote application	Multi-step speed application	PID control application	Multi-purpose application	Motor potentiometer application	Unit	ID	Description
3.2.1	Rem Control Place	0	0	0	0	0	0		172	0 = I/O Control
3.2.2	Local/Remote	0	0	0	0	0	0		211	0 = Remote
3.2.6	I/O A Logic	2	2	2	2	2	2		300	2 = Forw-Back (edge)
3.2.7	I/O B Logic	2	2	2	2	2	2		363	2 = Forw-Back (edge)

Table 135: Default Values of Parameters of Group 3.3

Index	Parameter	Standard application	Local/Remote application	Multi-step speed application	PID control application	Multi-purpose application	Motor potentiometer application	Unit	ID	Description
3.3.1.5	I/O A Ref Sel	6	5	6	7	6	8		117	5 = AI2 6 = AI1 + AI2 7 = PID 8 = Motor Potentiometer
3.3.1.6	I/O B Ref Sel	4	4	4	4	4	4		131	4 = AI1
3.3.1.7	Keypad Ref Sel	2	2	2	2	2	2		121	2 = Keypad Reference
3.3.1.10	Fieldbus Ref Sel	3	3	3	3	3	3		122	3 = Fieldbus Reference
3.3.2.1	Torque Ref Sel	0	0	0	0	4	0		641	0 = Not Used 4 = AI2
3.3.3.1	Preset Freq Mode	-	-	0	0	0	0		182	0 = Binary Coded
3.3.3.3	Preset Freq 1	-	-	10.0	10.0	5.0	10.0		105	
3.3.3.4	Preset Freq 2	-	-	15.0	-	-	-	Hz	106	
3.3.3.5	Preset Freq 3	-	-	20.0	-	-	-	Hz	126	
3.3.3.6	Preset Freq 4	-	-	25.0	-	-	-	Hz	127	
3.3.3.7	Preset Freq 5	-	-	30.0	-	-	-	Hz	128	
3.3.3.8	Preset Freq 6	-	-	40.0	-	-	-	Hz	129	
3.3.3.9	Preset Freq 7	-	-	50.0	-	-	-	Hz	130	

Table 136: Default Values of Parameters of Group 3.5

Index	Parameter	Standard application	Local/Remote application	Multi-step speed application	PID control application	Multi-purpose application	Motor potentiometer application	Unit	ID	Description
3.5.1.1	Ctrl Signal 1 A	100	100	100	100	100	100		403	100 = DigIN SlotA.1
3.5.1.2	Ctrl Signal 2 A	101	101	101	0	101	101		404	0 = DigIN Slot0.1 101 = DigIN SlotA.2
3.5.1.4	Ctrl Signal 1 B	0	103	0	103	0	0		423	0 = DigIN Slot0.1 103 = DigIN SlotA.4
3.5.1.5	Ctrl Signal 2 B	-	104	-	-	-	-		424	104 = DigIN SlotA.5
3.5.1.7	I/O B Ctrl Force	0	105	0	105	0	0		425	0 = DigIN Slot0.1 105 = DigIN SlotA.6
3.5.1.8	I/O B Ref Force	0	105	0	105	0	0		343	0 = DigIN Slot0.1 105 = DigIN SlotA.6
3.5.1.9	Fieldbus Ctrl Force	0	0	0	0	0	0		411	0 = DigIN Slot0.1
3.5.1.10	Keypad Ctrl Force	0	0	0	0	0	0		410	0 = DigIN Slot0.1
3.5.1.11	External Fault Close	102	102	102	101	104	102		405	101 = DigIN SlotA.2 102 = DigIN SlotA.3 104 = DigIN SlotA.5
3.5.1.13	Fault Reset Close	105	0	0	102	102	0		414	0 = DigIN Slot0.1 102 = DigIN SlotA.3 105 = DigIN SlotA.6
3.5.1.19	Ramp 2 Selection	0	0	0	0	105	0		408	0 = DigIN Slot0.1 105 = DigIN SlotA.6
3.5.1.21	Preset Freq Sel0	103	0	103	104	103	103		419	0 = DigIN Slot0.1 103 = DigIN SlotA.4 104 = DigIN SlotA.5
3.5.1.22	Preset Freq Sel1	104	0	104	0	0	0		420	0 = DigIN Slot0.1 104 = DigIN SlotA.5
3.5.1.23	Preset Freq Sel2	0	0	105	0	0	0		421	0 = DigIN Slot0.1 105 = DigIN SlotA.6
3.5.1.24	MotPot UP	0	0	0	0	0	104		418	0 = DigIN Slot0.1 104 = DigIN SlotA.5
3.5.1.25	MotPot DOWN	0	0	0	0	0	105		417	0 = DigIN Slot0.1

Index	Parameter	Standard application	Local/Remote application	Multi-step speed application	PID control application	Multi-purpose application	Motor potentiometer application	Unit	ID	Description
										105 = DigIN SlotA.6
3.5.2.1.1	AI1 Signal Selection	100	100	100	100	100	100		377	100 = AnIN SlotA.1
3.5.2.1.2	AI1 Filter Time	0.1	0.1	0.1	0.1	0.1	0.1	s	378	
3.5.2.1.3	AI1 Signal Range	0	0	0	0	0	0		379	0 = 0...10 V/0...20 mA
3.5.2.1.4	AI1 Custom Min	0.0	0.0	0.0	0.0	0.0	0.0	%	380	
3.5.2.1.5	AI1 Custom Max	100.0	100.0	100.0	100.0	100.0	100.0	%	381	
3.5.2.1.6	AI1 Signal Inversion	0	0	0	0	0	0		387	0 = Normal
3.5.2.2.1	AI2 Signal Selection	101	101	101	101	101	101		388	101 = AnIN SlotA.2
3.5.2.2.2	AI2 Filter Time	0.1	0.1	0.1	0.1	0.1	0.1	s	389	
3.5.2.2.3	AI2 Signal Range	1	1	1	1	1	1		390	1 = 2...10 V/4...20 mA
3.5.2.2.4	AI2 Custom Min	0.0	0.0	0.0	0.0	0.0	0.0	%	391	
3.5.2.2.5	AI2 Custom Max	100.0	100.0	100.0	100.0	100.0	100.0	%	392	
3.5.2.2.6	AI2 Signal Inversion	0	0	0	0	0	0		398	0 = Normal
3.5.3.2.1	RO1 Function	2	2	2	2	2	2		11001	2 = Run
3.5.3.2.4	RO2 Function	3	3	3	3	3	3		11004	3 = Fault
3.5.3.2.7	RO3 Function	1	1	1	1	1	1		11007	1 = Ready
3.5.4.1.1	AO1 Function	2	2	2	2	2	2		10050	2 = Output Freq
3.5.4.1.2	AO1 Filter Time	1.0	1.0	1.0	1.0	1.0	1.0	s	10051	
3.5.4.1.3	AO1 Min Signal	0	0	0	0	0	0		10052	
3.5.4.1.4	AO1 Min Scale	0.0	0.0	0.0	0.0	0.0	0.0		10053	
3.5.4.1.5	AO1 Max Scale	0.0	0.0	0.0	0.0	0.0	0.0		10054	

Table 137: Default Values of Parameters of Group 3.13

Index	Parameter	Standard application	Local/ Remote application	Multi-step speed application	PID control application	Multi-purpose application	Motor potentiometer application	Unit	ID	Description
3.13.2.6	SP1 Source	-	-	-	3	-	-		332	3 = AI1
3.13.3.1	Function	-	-	-	1	-	-		333	1 = Source 1
3.13.3.3	FB 1 Source	-	-	-	2	-	-		334	2 = AI2

11.28 Settings for Different Motor Types

It is possible to make the U/f curve settings for PM motors and synchronous reluctance motors in two ways, automatically and manually.

11.28.1 Automatic Tuning of the U/f Curve

The U/f curve is automatically configured, when identification with rotation is done. Set P3.1.2.3 Switching Frequency (ID 601) before tuning the U/f curve.

⚠ CAUTION ⚠

ROTATING MOTOR HAZARD

Motor starts rotating during this action. Contact with a rotating motor can cause injury.

- Make sure that only trained and qualified personnel perform this action.

Automatic tuning of the U/f curve for PM motors

1. Set the motor nominal values.
 - a. P3.1.1.1 Motor Nominal Voltage, ID 110
 - b. P3.1.1.2 Motor Nominal Frequency, ID 111
 - c. P3.1.1.3 Motor Nominal Speed, ID 112
 - d. P3.1.1.4 Motor Nominal Current, ID 113
 - e. P3.1.1.5 Motor Cos Phi (Power Factor), ID 120
 - f. P3.1.1.6 Motor Nominal Power, ID 116
2. Set P3.1.2.1 Control Mode (ID 600) to 0 = *Frequency control*.
3. Set P3.1.2.2 Motor Type (ID 650) to 1 = *PM motor*.
4. Set P3.1.2.4 Identification (631) to 2 = *With rotation*.
5. Start the identification run by pressing the Start button within 20 s from the previous step.

Automatic tuning of the U/f curve for synchronous reluctance motors

1. Set the motor nominal values.
 - a. P3.1.1.1 Motor Nominal Voltage, ID 110
 - b. P3.1.1.2 Motor Nominal Frequency, ID 111
 - c. P3.1.1.3 Motor Nominal Speed, ID 112
 - d. P3.1.1.4 Motor Nominal Current, ID 113
 - e. P3.1.1.5 Motor Cos Phi (Power Factor), ID 120
 - f. P3.1.1.6 Motor Nominal Power, ID 116
2. Set P3.3.1.2 Maximum Frequency Reference (ID 102).



The nameplate of the motor sometimes gives the maximum rotation speed. When setting the maximum frequency reference, do not exceed the maximum rotation speed.

The motor is accelerated to 67% of the nominal value during the identification run. If the maximum frequency reference is below this value, the identification run fails.

3. Set P3.1.2.2 Motor Type (ID 650) to 2 = *Reluctance motor*.

4. Set P3.1.2.4 Identification (631) to 2 = *With rotation*.
5. Start the identification run by pressing the Start button within 20 s from the previous step.

11.28.2 Manual Tuning of the U/f Curve

Approximation of induced voltage at given frequency can be found by observing motor current (V2.3.4) when running motor without load and changing motor voltage by adjusting U/f curve.

The voltages and frequencies in these three points are determined by running the motor without load and adjusting the voltage so that the desired current without load is obtained.

Set P3.1.2.3 Switching Frequency (ID 601) before tuning the U/f curve.

Manual tuning of the U/f curve for PM motors

1. Set the motor nominal values.
 - a. P3.1.1.1 Motor Nominal Voltage, ID 110
 - b. P3.1.1.2 Motor Nominal Frequency, ID 111
 - c. P3.1.1.3 Motor Nominal Speed, ID 112
 - d. P3.1.1.4 Motor Nominal Current, ID 113
 - e. P3.1.1.5 Motor Cos Phi (Power Factor), ID 120
 - f. P3.1.1.6 Motor Nominal Power, ID 116
2. Set P3.1.2.1 Control Mode (ID 600) to 0 = *Frequency control*.
3. Set P3.1.2.2 Motor Type (ID 650) to 1 = *PM motor*.
4. Set P3.1.4.1 U/f ratio (ID 108) to 2 = *Programmable*.
5. Set P3.1.4.6 Zero Frequency Voltage (ID 606) to a low value (0...1.00%)
6. Start the drive with a zero frequency reference and monitor V2.3.4 Motor Current. Decrease or increase the zero frequency voltage until the motor current is 30...50% of motor nominal current (P3.1.1.4).
7. Set P3.1.4.4 U/f Midpoint Frequency (ID 604) as a percentage of motor nominal frequency, equal to the value of P3.1.4.6 Zero Frequency Voltage (ID 606). It can be calculated multiplying the motor nominal frequency by the percentage value of zero frequency voltage and dividing the result by 100.
If zero frequency voltage is 7%, the midpoint frequency must be 3.5 Hz and the motor nominal frequency must be 50 Hz.
8. Set P3.1.4.5 U/f Midpoint Voltage (605) equal to P3.1.4.6 Zero Frequency Voltage (606) multiplied by 1.4 as a first guess.
9. Start the drive without the load and increase the frequency reference while monitoring the motor current.

➔ If the motor current deviates too much from the zero frequency current (the same current as in step 6) at lower speeds (< 50% of nominal speed), decrease or increase P3.1.4.5 U/f Midpoint Voltage (ID 605).
If the motor current deviates too much from the zero frequency current (the same current as in step 6) at higher speeds (> 50% of nominal speed), decrease or increase P3.1.2.13 Stator Voltage Adjust (ID 659) (or P3.1.4.3 Voltage at Field Weakening Point, ID 603).

Manual tuning of the U/f curve for synchronous reluctance motors

1. Set the motor nominal values.
 - a. P3.1.1.1 Motor Nominal Voltage, ID 110
 - b. P3.1.1.2 Motor Nominal Frequency, ID 111
 - c. P3.1.1.3 Motor Nominal Speed, ID 112
 - d. P3.1.1.4 Motor Nominal Current, ID 113
 - e. P3.1.1.5 Motor Cos Phi (Power Factor), ID 120
 - f. P3.1.1.6 Motor Nominal Power, ID 116
2. Set P3.3.1.2 Maximum Frequency Reference (ID 102).

➔ The nameplate of the motor sometimes gives the maximum rotation speed. When setting the maximum frequency reference, do not exceed the maximum rotation speed.

3. Set P3.1.2.2 Motor Type (ID 650) to 2 = *Reluctance motor*.
4. The drive sets automatically P3.1.4.2 Field Weakening Point Frequency (ID 602) and P3.1.4.3 Voltage at Field Weakening Point (ID 603). Reconfigure them if necessary.
5. Set P3.1.4.1 U/f ratio (ID 108) to 2 = *Programmable*.
6. Set P3.1.4.6 Zero Frequency Voltage (ID 606) to a low value (0...1.00%)
7. Start the drive with a zero frequency reference and monitor V2.3.4 Motor Current. Decrease or increase the zero frequency voltage until the motor current is 40...60% of motor nominal current (P3.1.1.4).

8. Set P3.1.4.4 U/f Midpoint Frequency (ID 604) as a percentage of motor nominal frequency, equal to the value of P3.1.4.6 Zero Frequency Voltage (ID 606). It can be calculated multiplying the motor nominal frequency by the percentage value of zero frequency voltage and dividing the result by 100.
If zero frequency voltage is 7%, the midpoint frequency must be 3.5 Hz and the motor nominal frequency must be 50 Hz.
9. Set P3.1.4.5 U/f Midpoint Voltage (605) equal to P3.1.4.6 Zero Frequency Voltage (606) multiplied by 1.4 as a first guess.
10. Start the drive without the load and increase the frequency reference while monitoring the motor current.



If the motor current deviates too much from the zero frequency current (the same current as in step 7) at lower speeds (< 30% of nominal speed), decrease or increase P3.1.4.5 U/f Midpoint Voltage (ID 605).

If the motor current deviates too much from the zero frequency current (the same current as in step 7) at higher speeds (> 60% of nominal speed), decrease or increase P3.1.4.3 Voltage at Field Weakening Point (ID 603).

12 Fault tracing

12.1 Fault Types

When the control diagnostics of the AC drive find an unusual condition in the operation of the drive, the drive shows a notification about it. The notification can be seen on the display of the control panel. The display shows the code, the name, and a short description of the fault or alarm.

The source info tells the source of the fault, what caused it, where it occurred, and other data.

There are 3 different types of notification.

- An **info** does not affect the operation of the drive. The info must be reset.
- An **alarm** informs of unusual operation on the drive. It does not stop the drive. The alarm must be reset.
- A **fault** stops the drive. The drive must be reset and find a solution to the problem.

It is possible to program different responses for some faults in the application. See more in [6.9 Group 3.9: Protections](#).

Reset the fault with the [BACK/RESET] button on the keypad, or through the I/O terminal, fieldbus, or PC tool. The faults stay in the Fault history where they can be examined. See the different fault codes in [12.3 Fault Codes](#).

Before contacting the distributor or the factory because of unusual operation, prepare some data. Write down all the texts on the display, the fault code, the fault ID, the source info, the *Active Faults* list, and the *Fault History*.

12.2 Alarms and Warnings

In condition-based monitoring, for each feature, the user can define activation stages for warnings and alarms. The interpretation of alarm and warning color codes are as follows:

Green: No alarms are indicated. Condition-based monitoring operations continue.

Yellow: First indication of warning-stage 1 alarm is visible. Stage 1 warning fault are also shown as *Stage 1 Warning (S1)*. Notification to users to plan for maintenance operations. In this stage, condition-based monitoring operations continue.

Orange: Clear indication of warning-stage 2 alarm is visible. Stage 2 warning fault are also shown as *Stage 2 Warning (S2)*. Notification to users to act as soon as possible before the fault becomes critical.

Red: A critical alarm has occurred and condition-based monitoring operations has stopped.

12.3 Fault Codes

12.3.1 Fault Code 1, ID 1 - Overcurrent (Hardware Fault)

Cause

There is too high a current ($> 4 \times I_H$) in the motor cable.

- a sudden heavy load increase
- a short circuit in the motor cables
- the motor is not the correct type
- the parameter settings are not properly made

Troubleshooting

- Check the loading.
- Check the motor.
- Check the cables and connections.
- Make an identification run.
- Set the acceleration time longer (P3.4.1.2 and P3.4.2.2).

12.3.2 Fault Code 1, ID 2 - Overcurrent (Software Fault)

Cause

There is too high a current ($> 4 \times I_H$) in the motor cable.

- a sudden heavy load increase
- a short circuit in the motor cables
- the motor is not the correct type
- the parameter settings are not properly made

Troubleshooting

- Check the loading.
- Check the motor.
- Check the cables and connections.
- Make an identification run.
- Set the acceleration time longer (P3.4.1.2 and P3.4.2.2).

12.3.3 Fault Code 2, ID 10 - Overvoltage (Hardware Fault)

Cause

The DC link voltage is higher than the limits.

- too short a deceleration time
- high overvoltage spikes in the supply

Troubleshooting

- Set the deceleration time longer (P3.4.1.3 and P3.4.2.3).
- Use the brake chopper or the brake resistor. They are available as options.
- Activate the overvoltage controller.
- Check the input voltage.

12.3.4 Fault Code 2, ID 11 - Overvoltage (Software Fault)

Cause

The DC link voltage is higher than the limits.

- too short a deceleration time
- high overvoltage spikes in the supply

Troubleshooting

- Set the deceleration time longer (P3.4.1.3 and P3.4.2.3).
- Use the brake chopper or the brake resistor. They are available as options.
- Activate the overvoltage controller.
- Check the input voltage.

12.3.5 Fault Code 3, ID 20 - Earth Fault (Hardware Fault)

Cause

The measurement of current tells that the sum of the motor phase current is not zero.

- an insulation malfunction in the cables or the motor
- a filter (dU/dt, sine) malfunction

Troubleshooting

- Check the motor cables and the motor.
- Check the filters.

12.3.6 Fault Code 3, ID 21 - Earth fault (Software Fault)

Cause

The measurement of current tells that the sum of the motor phase current is not zero.

- an insulation malfunction in the cables or the motor
- a filter (dU/dt, sine) malfunction

Troubleshooting

- Check the motor cables and the motor.
- Check the filters.

12.3.7 Fault Code 5, ID 40 - Charging Switch

Cause

The charging switch is closed and the feedback information is OPEN.

- operation malfunction
- defective component

Troubleshooting

- Reset the fault and restart the drive.
- Check the feedback signal and the cable connection between the control board and the power board.
- If the fault occurs again, ask for instructions from your nearest distributor.

12.3.8 Fault Code 7, ID 60 - Saturation

Cause

- Defective IGBT.
- De-saturation short circuit in the IGBT.
- A short circuit or an overload in the brake resistor.

Troubleshooting

- This fault cannot be reset from the control panel.
- Switch off the power.
- DO NOT RESTART THE DRIVE or CONNECT THE POWER!
- Ask for instructions from the factory.

12.3.9 Fault Code 8, ID 600 - System Fault

Cause

- There is no communication between the control board and the power unit.

Troubleshooting

- Reset the fault and restart the drive.
- Download the latest software from the Danfoss Drives website. Update the drive with it.
- If the fault occurs again, ask for instructions from your nearest distributor.

12.3.10 Fault Code 8, ID 601 - System Fault

Cause

- There is no communication between the control board and the power.

Troubleshooting

- Reset the fault and restart the drive.
- Download the latest software from the Danfoss Drives website. Update the drive with it.
- If the fault occurs again, ask for instructions from your nearest distributor.

12.3.11 Fault Code 8, ID 602 - System Fault

Cause

- Defective component.
- Operation malfunction.

Troubleshooting

- Reset the fault and restart the drive.
- Download the latest software from the Danfoss Drives website. Update the drive with it.
- If the fault occurs again, ask for instructions from your nearest distributor.

12.3.12 Fault Code 8, ID 603 - System Fault

Cause

- Defective component.
- Operation malfunction.
- The voltage of auxiliary power in the power unit is too low.

Troubleshooting

- Reset the fault and restart the drive.
- Download the latest software from the Danfoss Drives website. Update the drive with it.
- If the fault occurs again, ask for instructions from your nearest distributor.

12.3.13 Fault Code 8, ID 604 - System Fault

Cause

- Defective component.
- Operation malfunction.
- Output phase voltage does not agree to the reference.
- Feedback fault.

Troubleshooting

- Reset the fault and restart the drive.
- Download the latest software from the Danfoss Drives website. Update the drive with it.
- If the fault occurs again, ask for instructions from your nearest distributor.

12.3.14 Fault Code 8, ID 605 - System Fault

Cause

- Defective component.
- Operation malfunction.

Troubleshooting

- Reset the fault and restart the drive.
- Download the latest software from the Danfoss Drives website. Update the drive with it.
- If the fault occurs again, ask for instructions from your nearest distributor.

12.3.15 Fault Code 8, ID 606 - System Fault

Cause

- The software of the control unit is not compatible with the software of the power unit.

Troubleshooting

- Reset the fault and restart the drive.
- Download the latest software from the Danfoss Drives website. Update the drive with it.
- If the fault occurs again, ask for instructions from your nearest distributor.

12.3.16 Fault Code 8, ID 607 - System Fault

Cause

- The software version cannot be read. There is no software in the power unit.
- Defective component.
- Operation malfunction (a problem in the power board or the measurement board).

Troubleshooting

- Reset the fault and restart the drive.
- Download the latest software from the Danfoss Drives website. Update the drive with it.
- If the fault occurs again, ask for instructions from your nearest distributor.

12.3.17 Fault Code 8, ID 608 - System Fault

Cause

- A CPU overload.

Troubleshooting

- Reset the fault and restart the drive.
- Download the latest software from the Danfoss Drives website. Update the drive with it.
- If the fault occurs again, ask for instructions from your nearest distributor.

12.3.18 Fault Code 8, ID 609 - System Fault

Cause

- Defective component.
- Operation malfunction.

Troubleshooting

- Reset the fault and make a power down of the drive twice.
- Download the latest software from the Danfoss Drives website. Update the drive with it.

12.3.19 Fault Code 8, ID 610 - System Fault

Cause

- Defective component.
- Operation malfunction.

Troubleshooting

- Reset the fault and restart.
- Download the latest software from the Danfoss Drives website. Update the drive with it.
- If the fault occurs again, ask for instructions from your nearest distributor.

12.3.20 Fault Code 8, ID 614 - System Fault

Cause

- Configuration error.
- Software error.
- Defective component (a defective control board).
- Operation malfunction.

Troubleshooting

- Reset the fault and restart.
- Download the latest software from the Danfoss Drives website. Update the drive with it.
- If the fault occurs again, ask for instructions from your nearest distributor.

12.3.21 Fault Code 8, ID 647 - System Fault

Cause

- Defective component.
- Operation malfunction.

Troubleshooting

- Reset the fault and restart.
- Download the latest software from the Danfoss Drives website. Update the drive with it.
- If the fault occurs again, ask for instructions from your nearest distributor.

12.3.22 Fault Code 8, ID 648 - System Fault

Cause

- Operation malfunction.
- The system software is not compatible with the application.

Troubleshooting

- Reset the fault and restart.
- Download the latest software from the Danfoss Drives website. Update the drive with it.
- If the fault occurs again, ask for instructions from your nearest distributor.

12.3.23 Fault Code 8, ID 649 - System Fault

Cause

- A resource overload.
- A parameter loading, restoring or saving malfunction.

Troubleshooting

- Load the factory default settings.
- Download the latest software from the Danfoss Drives website. Update the drive with it.

12.3.24 Fault Code 8, ID 667 - System Fault

Cause

- Ethernet PHY is not recognized or it is in the wrong state.

Troubleshooting

- Reset the fault and restart the AC drive.
- Download the newest software from the Danfoss Drives website. Update the drive with it.
- If the fault occurs again, ask for instructions from your nearest distributor.

12.3.25 Fault Code 8, ID 670 - System Fault

Cause

- The output voltage is too low because of overload, a defective component, or a shortcut.

Troubleshooting

- Check the loading of the auxiliary output.
- Reset the fault and restart the AC drive.
- Download the newest software from the Danfoss Drives website. Update the drive with it.
- If the fault occurs again, ask for instructions from your nearest distributor.

12.3.26 Fault Code 8, ID 827 - System Fault

Cause

- Invalid/incorrect license key provided (via keypad or VCX).
- The license key is incorrect or not for this drive.

Troubleshooting

- Reset the fault and restart the AC drive.
- Enter the license key to the AC drive again.
- Download the newest software from the Danfoss Drives website. Update the drive with it.
- If the fault occurs again, ask for instructions from your nearest distributor.

12.3.27 Fault Code 8, ID 828 - System Fault

Cause

- The entered license key was accepted and stored to the drive.

Troubleshooting

-

12.3.28 Fault Code 8, ID 829 - System Fault

Cause

- New licenses have been taken into use since the previous start-up.

Troubleshooting

-

12.3.29 Fault Code 8, ID 830 - System Fault

Cause

- Licenses have been removed from the drive.

Troubleshooting

-

12.3.30 Fault Code 9, ID 80 - Undervoltage (Fault)

Cause

The DC link voltage is lower than the limits.

- too low a supply voltage
- defective component
- a defective input fuse
- the external charge switch is not closed

NOTE! This fault becomes active only if the drive is in Run state.

Troubleshooting

- If there is a temporary supply voltage break, reset the fault and restart the drive.
- Do a check of the supply voltage. If the supply voltage is sufficient, there is an internal fault.
- Examine the electrical network for fault.
- Ask for instructions from your nearest distributor.

12.3.31 Fault Code 10, ID 91 - Input Phase

Cause

- supply voltage malfunction
- a defective fuse or malfunction in the supply cables

The load must be a minimum of 10–20% for the supervision to work.

Troubleshooting

- Check the supply voltage.
- Check the fuses.
- Check the supply cable.
- Check the rectifying bridge.
- Check the gate control of the thyristor (MR6->).

12.3.32 Fault Code 10, ID 92 - Input Phase

Cause

- Software-based input phase supervision.

Troubleshooting

- Check the supply voltage.
- Check the fuses.
- Check the supply cable.

NOTICE

This fault is only used with enclosure sizes MR9B, MR10, MR11, and MR12.

12.3.33 Fault Code 10, ID 94 - Input Phase

Cause

- Software-based input phase supervision.

Troubleshooting

- Check the supply voltage.
- Check the fuses.
- Check the supply cable.

NOTICE

This fault is only used with enclosure sizes MR11 and MR12.

12.3.34 Fault Code 11, ID 100 - Output Phase Supervision

Cause

The current measurement tells that there is no current in 1 motor phase.

- A motor or motor cables malfunction.
- Filter (dU/dt, sine wave) malfunction.

Troubleshooting

- Check the motor cable and the motor.
- Check the dU/dt or sine wave filter.

12.3.35 Fault Code 12, ID 110 - Brake Chopper Supervision (Hardware Fault)

Cause

- There is no brake resistor.
- The brake resistor is broken.
- A defective brake chopper.

Troubleshooting

- Check the brake resistor and the cabling. If they are in good condition, there is a fault in the resistor or the brake chopper. Ask instructions from your nearest distributor.

12.3.36 Fault Code 12, ID 111 - Brake Chopper Saturation Alarm

Cause

- There is no brake resistor.
- The brake resistor is broken.
- A defective brake chopper.

Troubleshooting

- Check the brake resistor and the cabling. If they are in good condition, there is a fault in the resistor or the brake chopper. Ask instructions from your nearest distributor.

12.3.37 Fault Code 13, ID 120 - AC Drive Undertemperature (Fault)

Cause

- Too low a temperature in the heat sink of the power unit or in the power board.

Troubleshooting

- The ambient temperature is too low for the drive. Move the drive in a warmer position.

12.3.38 Fault Code 14, ID 130 - AC Drive Overtemperature (Fault, Heat Sink)

Cause

- Too high a temperature in the heat sink of the power unit or in the power board.
- The temperature limits of the heat sink are different in all the enclosure sizes.

Troubleshooting

- Check the actual amount and flow of cooling air.
- Examine the heat sink for dust.
- Check the ambient temperature.
- Make sure that the switching frequency is not too high in relation to the ambient temperature and the motor load.
- Check the cooling fan.

12.3.39 Fault Code 14, ID 131 - AC Drive Overtemperature (Alarm, Heat Sink)

Cause

- Too high a temperature in the heat sink of the power unit or in the power board.
- The temperature limits of the heat sink are different in all the enclosure sizes.

Troubleshooting

- Check the actual amount and flow of cooling air.
- Examine the heat sink for dust.
- Check the ambient temperature.
- Make sure that the switching frequency is not too high in relation to the ambient temperature and the motor load.
- Check the cooling fan.

12.3.40 Fault Code 14, ID 132 - AC Drive Overtemperature (Fault, Board)

Cause

- Too high a temperature in the heat sink of the power unit or in the power board.
- The temperature limits of the heat sink are different in all the enclosure sizes.

Troubleshooting

- Check the actual amount and flow of cooling air.
- Examine the heat sink for dust.
- Check the ambient temperature.
- Make sure that the switching frequency is not too high in relation to the ambient temperature and the motor load.
- Check the cooling fan.

12.3.41 Fault Code 14, ID 133 - AC Drive Overtemperature (Alarm, Board)

Cause

- Too high a temperature in the heat sink of the power unit or in the power board.
- The temperature limits of the heat sink are different in all the enclosure sizes.

Troubleshooting

- Check the actual amount and flow of cooling air.
- Examine the heat sink for dust.
- Check the ambient temperature.
- Make sure that the switching frequency is not too high in relation to the ambient temperature and the motor load.
- Check the cooling fan.

12.3.42 Fault Code 14, ID 134 - AC Drive Overtemperature (Fault)

Cause

- Power unit auxiliary temperature is too high.

Troubleshooting

- Check the actual amount and flow of cooling air.
- Examine the heat sink for dust.
- Check the ambient temperature.
- Make sure that the switching frequency is not too high in relation to the ambient temperature and the motor load.
- Check the cooling fan.

12.3.43 Fault Code 14, ID 136 - Overvoltage Protection Circuit Temperature (Alarm)

Cause

- Too high an output capacitance or a ground fault in the floating network.

Troubleshooting

- Check the cables and the motor.

12.3.44 Fault Code 14, ID 137 - Overvoltage Protection Circuit Temperature (Fault)

Cause

- Too high an output capacitance or a ground fault in the floating network.

Troubleshooting

- Check the cables and the motor.

12.3.45 Fault Code 14, ID 138 - AC Drive Overtemperature (Fault)

Cause

- Output filter temperature is too high.

Troubleshooting

- Check the motor cables and the motor.
- Check the correct amount and flow of cooling air.
- Check the ambient temperature.

12.3.46 Fault Code 14, ID 139 - AC Drive Overtemperature (Fault)

Cause

- Brake chopper temperature is too high.

Troubleshooting

- Check the correct amount and flow of cooling air.
- Check the heat sink of the brake chopper for dust.
- Check the ambient temperature.

12.3.47 Fault Code 15, ID 140 - Motor Stall

Cause

- The motor stalled.

Troubleshooting

- Check the motor and the load.

12.3.48 Fault Code 16, ID 150 - Motor Overtemperature

Cause

- There is too heavy a load on the motor.

Troubleshooting

- Decrease the motor load. If there is no motor overload, check the motor thermal protection parameters (parameter group 3.9 Protections).

12.3.49 Fault Code 17, ID 160 - Motor Underload

Cause

- There is not a sufficient load on the motor.

Troubleshooting

- Check the load.
- Check the parameters.
- Check the dU/dt and sine wave filters.

12.3.50 Fault Code 18, ID 170 - Unbalance

Cause

- The current is unbalanced between power units.

Troubleshooting

- Check the motor cables and connections.
- Check the output filters (dU/dt filter, sine filter).
- Reset the fault and restart the drive.
- If the fault occurs again, ask for instructions from your nearest service center or distributor. Report carefully all the used software, application and options.

NOTICE

This fault is only used with enclosure sizes MR11 and MR12.

12.3.51 Fault Code 18, ID 171 - Unbalance

Cause

- The DC voltage is unbalanced between power units.

Troubleshooting

- Check the DC link cables between the power units.
- Check the motor cables and connections.
- Check the output filters (dU/dt filter, sine filter).
- Reset the fault and restart the drive.
- If the fault occurs again, ask for instructions from your nearest service center or distributor. Report carefully all the used software, application, and options.

NOTICE

This fault is only used with enclosure sizes MR11 and MR12.

12.3.52 Fault Code 18, ID 173 - Unbalance (Alarm)

Cause

- The current is unbalanced between power units.

Troubleshooting

- Check the installation and the motor cables.
- Redo the IGBT ID run.
- The event response can be set to No Action.

NOTICE

This fault is only used with enclosure sizes MR11 and MR12.

12.3.53 Fault Code 19, ID 180 - Power Overload (Short-time Supervision)

Cause

- The power of the drive is too high.

Troubleshooting

- Decrease the load.
- Examine the dimensions of drive. Examine if it is too small for the load.

12.3.54 Fault Code 19, ID 181 - Power Overload (Long-time Supervision)

Cause

- The power of the drive is too high.

Troubleshooting

- Decrease the load.
- Examine the dimensions of drive. Examine if it is too small for the load.

12.3.55 Fault Code 25, ID 240 - Motor Control Fault

Cause

This fault is available only if you use a customer-specific application. A malfunction in the start angle identification.

- The rotor moves during identification.
- The new angle does not agree with the old value.

Troubleshooting

- Reset the fault and restart the drive.
- Increase the identification current.
- See the fault history source for more information.

12.3.56 Fault Code 25, ID 241 - Motor Control Fault

Cause

This fault is available only if you use a customer-specific application. A malfunction in the start angle identification.

- The rotor moves during identification.
- The new angle does not agree with the old value.

Troubleshooting

- Reset the fault and restart the drive.
- Increase the identification current.
- See the fault history source for more information.

12.3.57 Fault Code 26, ID 250 - Start-up Prevented

Cause

- It is not possible to do a start-up of the drive. When the Run request is ON, a new software (a firmware or an application), a parameter setting, or other file that affects the operation of the drive, is loaded to drive.

Troubleshooting

- Reset the fault and stop the drive.
- Load the software and start the drive.

12.3.58 Fault Code 29, ID 280 - ATEX Thermistor

Cause

- The ATEX thermistor tells that there is an overtemperature.

Troubleshooting

- Reset the fault. Check the thermistor and its connections.

12.3.59 Fault Code 30, ID 290 - Safe Off

Cause

- The safe Off signal A does not let you set the drive to the READY state.

Troubleshooting

- Reset the fault and restart the drive.
- Check the signals from the control board to the power unit and the D connector.

12.3.60 Fault Code 30, ID 291 - Safe Off

Cause

- The safe Off signal B does not let you set the drive to the READY state.

Troubleshooting

- Reset the fault and restart the drive.
- Check the signals from the control board to the power unit and the D connector.

12.3.61 Fault Code 30, ID 500 - Safety Configuration

Cause

- The safety configuration switch was installed.

Troubleshooting

- Remove the safety configuration switch from the control board.

12.3.62 Fault Code 30, ID 501 - Safety Configuration

Cause

- There are too many STO option boards. It is possible to have only 1.

Troubleshooting

- Keep 1 of the STO option boards. Remove the others. See the safety manual.

12.3.63 Fault Code 30, ID 502 - Safety Configuration

Cause

- The STO option board was installed in an incorrect slot.

Troubleshooting

- Put the STO option board into the correct slot. See the OPTBJ STO Safety manual.

12.3.64 Fault Code 30, ID 503 - Safety configuration

Cause

- There is no safety configuration switch on the control board.

Troubleshooting

- Install the safety configuration switch on the control board. See the safety manual.

12.3.65 Fault Code 30, ID 504 - Safety configuration

Cause

- The safety configuration switch was installed incorrectly on the control board.

Troubleshooting

- Install the safety configuration switch into the correct position on the control board. See the safety manual.

12.3.66 Fault Code 30, ID 505 - Safety configuration

Cause

- The safety configuration switch was installed incorrectly on the STO option board.

Troubleshooting

- Check the installation of the safety configuration switch on the STO option board. See the safety manual.

12.3.67 Fault Code 30, ID 506 - Safety configuration

Cause

- There is no communication with the STO option board.

Troubleshooting

- Check the installation of the STO option board. See the safety manual.

12.3.68 Fault Code 30, ID 507 - Safety configuration

Cause

- The STO option board is not compatible with the hardware.

Troubleshooting

- Reset the drive and restart it. If the fault occurs again, ask for instructions from your nearest distributor.

12.3.69 Fault Code 30, ID 520 - Safety diagnostics

Cause

- The STO inputs have a different status.

Troubleshooting

- Check the external safety switch. Check the input connection and cable of the safety switch.
- Reset the drive and restart.
- If the fault occurs again, ask for instructions from your nearest distributor.

12.3.70 Fault Code 30, ID 521 - Safety diagnostics

Cause

- A malfunction in the ATEX thermistor diagnostic. There is no connection in the ATEX thermistor input.

Troubleshooting

- Reset the drive and restart.
- If the fault occurs again, change the option board.

12.3.71 Fault Code 30, ID 522 - Safety diagnostics

Cause

- A short circuit in the connection of the ATEX thermistor input.

Troubleshooting

- Check the ATEX thermistor input connection.
- Check the external ATEX connection.
- Check the external ATEX thermistor.

12.3.72 Fault Code 30, ID 523 - Safety diagnostics

Cause

- A problem occurred in the internal safety circuit.

Troubleshooting

- Reset the drive and restart.
- If the fault occurs again, ask for instructions from your nearest distributor.

12.3.73 Fault Code 30, ID 524 - Safety diagnostics

Cause

- An overvoltage in the safety option board.

Troubleshooting

- Reset the drive and restart.
- If the fault occurs again, ask for instructions from your nearest distributor.

12.3.74 Fault Code 30, ID 525 - Safety Diagnostics

Cause

- An undervoltage in the safety option board.

Troubleshooting

- Reset the drive and restart.
- If the fault occurs again, ask for instructions from your nearest distributor.

12.3.75 Fault Code 30, ID 526 - Safety Diagnostics

Cause

- An internal malfunction in the safety option board CPU or in the memory handling.

Troubleshooting

- Reset the drive and restart.
- If the fault occurs again, ask for instructions from your nearest distributor.

12.3.76 Fault Code 30, ID 527 - Safety Diagnostics

Cause

- An internal malfunction in the safety function.

Troubleshooting

- Reset the drive and restart.
- If the fault occurs again, ask for instructions from your nearest distributor.

12.3.77 Fault Code 30, ID 530 - Safe Torque Off

Cause

- An emergency stop was connected or some other STO operation was activated.

Troubleshooting

- When the STO function is activated, the drive is in safe state.

12.3.78 Fault Code 32, ID 311 - Fan Cooling

Cause

- The fan speed does not agree to the speed reference accurately, but the drive operates correctly.
- This fault shows only in the MR7 and in enclosure sizes bigger than MR7.

Troubleshooting

- Reset the fault and restart the drive.
- Clean or replace the fan.

12.3.79 Fault Code 32, ID 312 - Fan Cooling

Cause

- The fan life time (that is, 50 000 h) is complete.

Troubleshooting

- Replace the fan and reset the life time counter of the fan.

12.3.80 Fault Code 33, ID 320 - Fire Mode Enabled

Cause

- The fire mode of the drive is enabled. The protections of the drive are disabled or autoreset.

Troubleshooting

- Check the parameter settings and the signals.
- This alarm is reset automatically when fire mode is disabled.

12.3.81 Fault Code 37, ID 361 - Device Changed (Same Type)

Cause

- The power unit was replaced by a new one that has the same size. The device is ready to be used. The parameters are available in the drive.

Troubleshooting

- Reset the fault. The drive reboots after you reset the fault.

12.3.82 Fault Code 37, ID 362 - Device Changed (Same Type)

Cause

- The option board in slot B was replaced by a new one that you have used before in the same slot. The device is ready to be used.

Troubleshooting

- Reset the fault. The drive starts to use the old parameter settings.

12.3.83 Fault Code 37, ID 363 - Device Changed (Same Type)

Cause

- The option board in slot C was replaced by a new one that you have used before in the same slot. The device is ready to be used.

Troubleshooting

- Reset the fault. The drive starts to use the old parameter settings.

12.3.84 Fault Code 37, ID 364 - Device Changed (Same Type)

Cause

- The option board in slot D was replaced by a new one that you have used before in the same slot. The device is ready to be used.

Troubleshooting

- Reset the fault. The drive starts to use the old parameter settings.

12.3.85 Fault Code 37, ID 365 - Device Changed (Same Type)

Cause

- The option board in slot E was replaced by a new one that you have used before in the same slot. The device is ready to be used.

Troubleshooting

- Reset the fault. The drive starts to use the old parameter settings.

12.3.86 Fault Code 38, ID 372 - Device Added (Same Type)

Cause

- An option board was put into slot B. You have used the option board before in the same slot.

Troubleshooting

- The device is ready for use. The drive starts to use the old parameter settings.

12.3.87 Fault Code 38, ID 373 - Device Added (Same Type)

Cause

- An option board was put into slot C. You have used the option board before in the same slot.

Troubleshooting

- The device is ready for use. The drive starts to use the old parameter settings.

12.3.88 Fault Code 38, ID 374 - Device Added (Same Type)

Cause

- An option board was put into slot D. You have used the option board before in the same slot.

Troubleshooting

- The device is ready for use. The drive starts to use the old parameter settings.

12.3.89 Fault Code 38, ID 375 - Device Added (Same Type)

Cause

- An option board was put into slot E. You have used the option board before in the same slot.

Troubleshooting

- The device is ready for use. The drive starts to use the old parameter settings.

12.3.90 Fault Code 39, ID 382 - Device Removed

Cause

- An option board was removed from slot A or B.

Troubleshooting

- The device is not available. Reset the fault.

12.3.91 Fault Code 39, ID 383 - Device Removed

Cause

- An option board was removed from slot C.

Troubleshooting

- The device is not available. Reset the fault.

12.3.92 Fault Code 39, ID 384 - Device Removed

Cause

- An option board was removed from slot D.

Troubleshooting

- The device is not available. Reset the fault.

12.3.93 Fault Code 39, ID 385 - Device Removed

Cause

- An option board was removed from slot E.

Troubleshooting

- The device is not available. Reset the fault.

12.3.94 Fault Code 40, ID 390 - Device Unknown

Cause

- An unknown device was connected (the power unit/option board).

Troubleshooting

- The device is not available. If the fault occurs again, ask for instructions from your nearest distributor.

12.3.95 Fault Code 41, ID 400 - IGBT Temperature

Cause

The calculated IGBT temperature is too high.

- too high a motor load
- too high an ambient temperature
- hardware malfunction

Troubleshooting

- Check the parameter settings.
- Examine the actual amount and flow of cooling air.
- Check the ambient temperature.
- Examine the heatsink for dust.
- Make sure that the switching frequency is not too high in relation to the ambient temperature and the motor load.
- Check the cooling fan.
- Make an identification run.

12.3.96 Fault Code 44, ID 431 - Device Changed (Different Type)

Cause

- There is a new power unit of a different type. Parameters are not available in the settings.

Troubleshooting

- Reset the fault. The drive reboots after you reset the fault.
- Set the power unit parameters again.

12.3.97 Fault Code 44, ID 433 - Device Changed (Different Type)

Cause

- The option board in slot C was replaced by a new one that you have not used before in the same slot. No parameter settings are saved.

Troubleshooting

- Reset the fault. Set the option board parameters again.

12.3.98 Fault Code 44, ID 434 - Device Changed (Different Type)

Cause

- The option board in slot D was replaced by a new one that you have not used before in the same slot. No parameter settings are saved.

Troubleshooting

- Reset the fault. Set the option board parameters again.

12.3.99 Fault Code 44, ID 435 - Device Changed (Different Type)

Cause

- The option board in slot E was replaced by a new one that you have not used before in the same slot. No parameter settings are saved.

Troubleshooting

- Reset the fault. Set the option board parameters again.

12.3.100 Fault Code 45, ID 441 - Device Added (Different Type)

Cause

- There is a new power unit of a different type. Parameters are not available in the settings.

Troubleshooting

- Reset the fault. The drive reboots after you reset the fault.
- Set the power unit parameters again.

12.3.101 Fault Code 45, ID 443 - Device Added (Different Type)

Cause

- A new option board, that you have not used before in the same slot, was put in slot C. No parameter settings are saved.

Troubleshooting

- Set the option board parameters again.

12.3.102 Fault Code 45, ID 444 - Device Added (Different Type)

Cause

- A new option board, that you have not used before in the same slot, was put in slot D. No parameter settings are saved.

Troubleshooting

- Set the option board parameters again.

12.3.103 Fault Code 45, ID 445 - Device Added (Different Type)

Cause

- A new option board, that you have not used before in the same slot, was put in slot E. No parameter settings are saved.

Troubleshooting

- Set the option board parameters again.

12.3.104 Fault Code 46, ID 662 - Real Time Clock

Cause

- The voltage of the RTC battery is low.

Troubleshooting

- Replace the battery.

12.3.105 Fault Code 47, ID 663 - Software Updated

Cause

- The software of the drive was updated, the full software package or an application.

Troubleshooting

- No steps are necessary.

12.3.106 Fault Code 50, ID 1050 - AI Low Fault

Cause

- 1 or more of the available analog input signals is below 50% of the minimum signal range.
- A control cable is defective or loose.
- A malfunction in a signal source.

Troubleshooting

- Replace the defective parts.
- Check the analog input circuit.
- Make sure that parameter AI1 Signal Range is set correctly.

12.3.107 Fault Code 51, ID 1051 - Device External Fault

Cause

- The digital input signal that is set with parameter P3.5.1.11 or P3.5.1.12 was activated.

Troubleshooting

- This is a user-defined fault.
- Check the digital inputs and schematics.

12.3.108 Fault Code 52, ID 1052 - Keypad Communication Fault

Cause

- The connection between the control panel and the drive is defective.

Troubleshooting

- Check the control panel connection and the control panel cable if you have it.

12.3.109 Fault Code 52, ID 1352 - Keypad Communication Fault

Cause

- The connection between the control panel and the drive is defective.

Troubleshooting

- Check the control panel connection and the control panel cable if you have it.

12.3.110 Fault Code 53, ID 1053 - Fieldbus Communication Fault

Cause

- The data connection between the fieldbus master and the fieldbus board is defective.

Troubleshooting

- Check the installation and fieldbus master.

12.3.111 Fault Code 53, ID 1054 - Redundant Switchover

Cause

- The data connection between controlling fieldbus and the drive has timed out. Redundant control has changed the controlling fieldbus connection.

Troubleshooting

- Check the installation and the communication cables.

12.3.112 Fault Code 53, ID 1055 - Redundant Timeout

Cause

- The data connection between controlling fieldbus protocols and the drive has timed out.

Troubleshooting

- Check the installation and the communication cables.

12.3.113 Fault Code 54, ID 1354 - Slot A fault

Cause

- A defective option board or slot.

Troubleshooting

- Check the board and the slot.
- Ask for instructions from your nearest distributor.

12.3.114 Fault Code 54, ID 1454 - Slot B fault

Cause

- A defective option board or slot.

Troubleshooting

- Check the board and the slot.
- Ask for instructions from your nearest distributor.

12.3.115 Fault Code 54, ID 1554 - Slot C fault

Cause

- A defective option board or slot.

Troubleshooting

- Check the board and the slot.
- Ask for instructions from your nearest distributor.

12.3.116 Fault Code 54, ID 1654 - Slot D fault

Cause

- A defective option board or slot.

Troubleshooting

- Check the board and the slot.
- Ask for instructions from your nearest distributor.

12.3.117 Fault Code 54, ID 1754 - Slot E fault

Cause

- A defective option board or slot.

Troubleshooting

- Check the board and the slot.
- Ask for instructions from your nearest distributor.

12.3.118 Fault Code 57, ID 1057 - Identification

Cause

- There was a failure in the identification run.

Troubleshooting

- Make sure that the motor is connected to the drive.
- Make sure that there is no load on the motor shaft.
- Make sure that the start command is not removed before the identification run is complete.

12.3.119 Fault Code 57, ID 1157 - Identification

Cause

- During the identification run, drive was not able to reach required frequency reference.

Troubleshooting

- Make sure that minimum and maximum frequency references are set correctly. Too low maximum frequency can prevent drive from reaching required frequency.

12.3.120 Fault Code 57, ID 1257 - Identification

Cause

- During the identification run, drive was not able to reach required frequency reference.

Troubleshooting

- Make sure that acceleration time is set correctly. Too long acceleration time can prevent drive from reaching required frequency in 40 seconds.

12.3.121 Fault Code 57, ID 1357 - Identification

Cause

- During the identification run, drive was not able to reach required frequency reference.

Troubleshooting

- Make sure that current, torque, and power limits of the drive are set correctly. Too low limit settings can prevent drive from reaching required frequency.

12.3.122 Fault Code 58, ID 1058 - Mechanical Brake

Cause

- The actual status of the mechanical brake is different from the control signal for longer than the value of P3.20.6.

Troubleshooting

- Check the status and connections of the mechanical brake. See parameter P3.5.1.44 and parameter group 3.20: Mechanical brake.

12.3.123 Fault Code 63, ID 1063 - Quick Stop Fault

Cause

- The quick stop function is activated.

Troubleshooting

- Find the cause for the quick stop activation. After you find it, correct it. Reset the fault and restart the drive.
- See parameter P3.5.1.26 and the quick stop parameters.

12.3.124 Fault Code 63, ID 1363 - Quick Stop Alarm

Cause

- The quick stop function is activated.

Troubleshooting

- Find the cause for the quick stop activation. After you find it, correct it. Reset the fault and restart the drive.
- See parameter P3.5.1.26 and the quick stop parameters.

12.3.125 Fault Code 65, ID 1065 - PC Communication Fault

Cause

- The data connection between the PC and the drive is defective.

Troubleshooting

- Check the installation, cable, and terminals between the PC and the drive.

12.3.126 Fault Code 66, ID 1366 - Thermistor Input 1 Fault

Cause

- The motor temperature increased.

Troubleshooting

- Check the motor cooling and the load.
- Check the thermistor connection.
- If the thermistor input is not used, you have to short-circuit it.
- Ask for instructions from your nearest distributor.

12.3.127 Fault Code 66, ID 1466 - Thermistor Input 2 Fault

Cause

- The motor temperature increased.

Troubleshooting

- Check the motor cooling and the load.
- Check the thermistor connection.
- If the thermistor input is not used, you have to short-circuit it.
- Ask for instructions from your nearest distributor.

12.3.128 Fault Code 66, ID 1566 - Thermistor Input 3 Fault

Cause

- The motor temperature increased.

Troubleshooting

- Check the motor cooling and the load.
- Check the thermistor connection.
- If the thermistor input is not used, you have to short-circuit it.
- Ask for instructions from your nearest distributor.

12.3.129 Fault Code 68, ID 1301 - Maintenance Counter 1 Alarm

Cause

- The value of the maintenance counter is higher than the alarm limit.

Troubleshooting

- Do the necessary maintenance.
- Reset the counter. See parameter B3.16.4 or P3.5.1.40.

12.3.130 Fault Code 68, ID 1302 - Maintenance Counter 1 Fault

Cause

- The value of the maintenance counter is higher than the fault limit.

Troubleshooting

- Do the necessary maintenance.
- Reset the counter. See parameter B3.16.4 or P3.5.1.40.

12.3.131 Fault Code 68, ID 1303 - Maintenance Counter 2 Alarm

Cause

- The value of the maintenance counter is higher than the alarm limit.

Troubleshooting

- Do the necessary maintenance.
- Reset the counter. See parameter B3.16.4 or P3.5.1.40.

12.3.132 Fault Code 68, ID 1304 - Maintenance Counter 2 Fault

Cause

- The value of the maintenance counter is higher than the fault limit.

Troubleshooting

- Do the necessary maintenance.
- Reset the counter. See parameter B3.16.4 or P3.5.1.40.

12.3.133 Fault Code 69, ID 1310 - Fieldbus Mapping Error

Cause

- The ID number that is used to map the values to Fieldbus Process Data Out is not valid.

Troubleshooting

- Check the parameters in the Fieldbus Data menu.

12.3.134 Fault Code 69, ID 1311 - Fieldbus Mapping Error

Cause

- It is not possible to convert 1 or more values for Fieldbus Process Data Out.
- The type of the value is undefined.

Troubleshooting

- Check the parameters in the Fieldbus Data menu.

12.3.135 Fault Code 69, ID 1312 - Fieldbus Mapping Error

Cause

- There is an overflow when the values for Fieldbus Process Data Out (16-bit) are mapped and converted.

Troubleshooting

- Check the parameters in the Fieldbus Data menu.

12.3.136 Fault Code 70, ID 1120 - BaselineRun Failed

Cause

- There was a failure during the baseline run.

Troubleshooting

- Do a check of the parameters in the baseline run settings.

12.3.137 Fault Code 71, ID 1121 - Stator Winding: Current Warning S1

Cause

- Current unbalance has exceeded the detection high limit. Early fault detected in motor.

Troubleshooting

- Check motor stator windings.

12.3.138 Fault Code 71, ID 1122 - Stator Winding: Current Warning S2

Cause

- Current unbalance has exceeded the detection high limit. Severe fault can soon occur in the motor.

Troubleshooting

- Check motor stator windings.

12.3.139 Fault Code 71, ID 1123 - Stator Winding: Current Alarm/Fault

Cause

- Current unbalance has exceeded the detection high limit. Severe fault is detected in motor.

Troubleshooting

- Check motor stator windings.

12.3.140 Fault Code 71, ID 1127 - Vibration Warning S1

Cause

- Vibration has exceeded the detection high limit. Early fault detected in motor.

Troubleshooting

- Check root cause for increased vibration.

12.3.141 Fault Code 71, ID 1128 - Vibration Warning S2

Cause

- Vibration has exceeded the detection high limit. Severe fault can occur soon in the motor.

Troubleshooting

- Check root cause for increased vibration.

12.3.142 Fault Code 71, ID 1129 - Vibration Alarm/Fault

Cause

- Vibration has exceeded the detection high limit. Severe fault detected in motor.

Troubleshooting

- Check root cause for increased vibration.

12.3.143 Fault Code 71, ID 1130 - Load Warning S1

Cause

- Load outside of the window limits. Early fault detected in motor.

Troubleshooting

- Check root cause for excessive overload or underload.

12.3.144 Fault Code 71, ID 1131 - Load Warning S2

Cause

- Load outside of the window limits. Severe fault can occur soon in the motor.

Troubleshooting

- Check root cause for excessive overload or underload.

12.3.145 Fault Code 71, ID 1132 - Load Alarm/Fault

Cause

- Load outside of the window limits. Severe fault is detected in motor.

Troubleshooting

- Check root cause for excessive overload or underload.

12.3.146 Fault Code 76, ID 1076 - Start Prevented

Cause

- The start command is blocked to prevent the accidental rotation of the motor during the first power-up.

Troubleshooting

- Reset the drive to start the correct operation. The parameter settings tell if it is necessary to restart the drive.

12.3.147 Fault Code 77, ID 1077 - > 5 Connections

Cause

- There are more than 5 active fieldbus or PC tool connections. You can use only 5 connections at the same time.

Troubleshooting

- Leave 5 active connections. Remove the other connections.

12.3.148 Fault Code 78, ID 1078 - Identification Ongoing

Cause

- The drive is running the identification for the motor.

Troubleshooting

- You can stop the identification run at any time by removing the start command. When the identification run is completed, a new start command is needed to start the drive.

12.3.149 Fault Code 100, ID 1100 - Soft Fill Timeout

Cause

- There is a timeout in the Soft fill function in the PID controller. The process value was not achieved in the time limit.
- A pipe that broke can be the cause.

Troubleshooting

- Check the process.
- Check the parameters in the menu M3.13.8.

12.3.150 Fault Code 101, ID 1101 - Feedback Supervision Fault (PID 1)

Cause

- The feedback value is not in the supervision limits (P3.13.6.2 and P3.13.6.3) and the delay (P3.13.6.4), if you set the delay.

Troubleshooting

- Check the process.
- Check the parameter settings, the supervision limits, and the delay.

12.3.151 Fault Code 105, ID 1105 - Feedback Supervision Fault (ExtPID)

Cause

- The feedback value is not in the supervision limits (P3.14.4.2 and P3.14.4.3) and the delay (P3.14.4.4), if you set the delay.

Troubleshooting

- Check the process.
- Check the parameter settings, the supervision limits, and the delay.

12.3.152 Fault Code 109, ID 1109 - Input Pressure Supervision

Cause

- The supervision signal of the input pressure (P3.13.9.2) is lower than the alarm limit (P3.13.9.7).

Troubleshooting

- Check the process.
- Check the parameters in menu M3.13.9.
- Check the input pressure sensor and connections.

12.3.153 Fault Code 109, ID 1409 - Input Pressure Supervision

Cause

- The supervision signal of the input pressure (P3.13.9.2) is lower than the fault limit (P3.13.9.8).

Troubleshooting

- Check the process.
- Check the parameters in menu M3.13.9.
- Check the input pressure sensor and connections.

12.3.154 Fault Code 111, ID 1315 - Temperature Fault 1

Cause

- 1 or more of the temperature input signals (set in P3.9.6.1) is higher than the alarm limit (P3.9.6.2).

Troubleshooting

- Find the cause of the temperature rise.
- Check the temperature sensor and connections.
- If no sensor is connected, make sure that the temperature input is hardwired.
- See the option board manual for more data.

12.3.155 Fault Code 111, ID 1316 - Temperature Fault 1

Cause

- 1 or more of the temperature input signals (set in P3.9.6.1) is higher than the fault limit (P3.9.6.3).

Troubleshooting

- Find the cause of the temperature rise.
- Check the temperature sensor and connections.
- If no sensor is connected, make sure that the temperature input is hardwired.
- See the option board manual for more data.

12.3.156 Fault Code 112, ID 1317 - Temperature Fault 2

Cause

- 1 or more of the temperature input signals (set in P3.9.6.5) is higher than the fault limit (P3.9.6.6).

Troubleshooting

- Find the cause of the temperature rise.
- Check the temperature sensor and connections.
- If no sensor is connected, make sure that the temperature input is hardwired.
- See the option board manual for more data.

12.3.157 Fault Code 112, ID 1318 - Temperature Fault 2

Cause

- 1 or more of the temperature input signals (set in P3.9.6.5) is higher than the fault limit (P3.9.6.7).

Troubleshooting

- Find the cause of the temperature rise.
- Check the temperature sensor and connections.
- If no sensor is connected, make sure that the temperature input is hardwired.
- See the option board manual for more data.

12.3.158 Fault Code 118, ID 1118 - AHF Over Temp

Cause

- The advanced harmonic filter function has caused an overtemperature fault through a digital input.

Troubleshooting

- Check the advanced harmonic filter function.

12.3.159 Fault Code 119, ID 1119 - Auto Cleaning

Cause

- The motor did not reach the expected speed reference during the auto cleaning sequence.

Troubleshooting

- Check the process.
- Check the auto cleaning parameter settings.

12.3.160 Fault Code 300, ID 700 - Unsupported

Cause

- The application is not compatible (it is unsupported).

Troubleshooting

- Replace the application.

12.3.161 Fault Code 300, ID 701 - Unsupported

Cause

- The option board or the slot is not compatible (it is unsupported).

Troubleshooting

- Remove the option board.

12.4 Total and Trip Counters

The AC drive has different counters based on the operation time of the drive and the energy consumption. Some of the counters measure total values and some can be reset.

The energy counters measure the energy that is taken from the supply network. The other counters are used to measure, for example, the operation time of the drive or the run-time of the motor.

It is possible to monitor all the counter values from the PC, control panel, or fieldbus. When using the PC or the control panel, it is possible to monitor the counter values in the Diagnostics menu. When using fieldbus, it is possible to read the counter values with the ID numbers.

12.4.1 Operating Time Counter

Resetting: not possible

Location: submenu Total counters

The value of the counter has 5 different 16-bit values. To read the value of the counter through fieldbus, use these ID numbers.

ID number	Counter value
ID 1754	Operating Time Counter (years)
ID 1755	Operating Time Counter (days)

ID number	Counter value
ID 1756	Operating Time Counter (hours)
ID 1757	Operating Time Counter (minutes)
ID 1758	Operating Time Counter (seconds)

Example

The value 1a 143d 02:21 is received from the operating time counter from the fieldbus.

- ID1754: 1 (years)
- ID1755: 143 (days)
- ID1756: 2 (hours)
- ID1757: 21 (minutes)
- ID1758: 0 (seconds)

12.4.2 Operating Time Trip Counter

The operating time trip counter of the control unit can be reset. It is in the submenu Trip counters. It is possible to reset the counter with the PC, the control panel, or the fieldbus. The value of the counter has 5 different 16-bit values. To read the value of the counter through fieldbus, use these ID numbers.

ID number	Counter value
ID 1766	Operating Time Trip Counter (years)
ID 1767	Operating Time Trip Counter (days)
ID 1768	Operating Time Trip Counter (hours)
ID 1769	Operating Time Trip Counter (minutes)
ID 1770	Operating Time Trip Counter (seconds)

Example

The value 1a 143d 02:21 is received from the operating time trip counter from the fieldbus.

- ID1766: 1 (years)
- ID1767: 143 (days)
- ID1768: 2 (hours)
- ID1769: 21 (minutes)
- ID1770: 0 (seconds)

ID number	Counter value
ID 2311	Operating Time Trip Counter Reset

To reset the energy trip counter, use the PC, the control panel, or the fieldbus. When using the PC or the control panel, reset the counter in the Diagnostics menu. When using the fieldbus, set a rising edge to ID 2311 Operating Time Trip Counter Reset.

12.4.3 Run Time Counter

The run time counter of the motor cannot be reset. It is in the submenu Total counters. The value of the counter has 5 different 16-bit values. To read the value of the counter through fieldbus, use these ID numbers.

ID number	Counter value
ID 1772	Run Time Counter (years)
ID 1773	Run Time Counter (days)

ID number	Counter value
ID 1774	Run Time Counter (hours)
ID 1775	Run Time Counter (minutes)
ID 1776	Run Time Counter (seconds)

Example

The value 1a 143d 02:21 is received from the run time counter from the fieldbus.

- ID1772: 1 (years)
- ID1773: 143 (days)
- ID1774: 2 (hours)
- ID1775: 21 (minutes)
- ID1776: 0 (seconds)

12.4.4 Power on Time Counter

The power on time counter of the power unit is in the submenu Total counters. It is not possible to reset the counter. The value of the counter has 5 different 16-bit values. To read the value of the counter through fieldbus, use these ID numbers.

ID number	Counter value
ID 1777	Power On Time Counter (years)
ID 1778	Power On Time Counter (days)
ID 1779	Power On Time Counter (hours)
ID 1780	Power On Time Counter (minutes)
ID 1781	Power On Time Counter (seconds)

Example

The value 1a 240d 02:18 is received from the power on time counter from the fieldbus.

- ID1777: 1 (years)
- ID1778: 240 (days)
- ID1779: 2 (hours)
- ID1780: 18 (minutes)
- ID1781: 0 (seconds)

12.4.5 Energy Counter

The energy counter counts the total quantity of energy that the drive gets from the supply network. The counter cannot be reset. To read the value of the counter through fieldbus, use these ID numbers.

ID number	Counter value
ID 2291	Energy Counter

The value always has 4 digits. The format and the unit of the counter change to agree with the energy counter value.

Example

- 0.001 kWh
- 0.010 kWh
- 0.100 kWh
- 1.000 kWh
- 10.00 kWh

- 100.0 kWh
- 1.000 MWh
- 10.00 MWh
- 100.0 MWh
- 1.000 GWh
- and so on

ID number	Counter value
ID 2303	Energy Counter Format

The energy counter format gives the position of the decimal point in the value of the Energy Counter.

- 40 = 4 digits, 0 fractional digits
- 41 = 4 digits, 1 fractional digit
- 42 = 4 digits, 2 fractional digits
- 43 = 4 digits, 3 fractional digits

Example

- 0.001 kWh (Format = 43)
- 100.0 kWh (Format = 41)
- 10.00 MWh (Format = 42)

ID number	Counter value
ID 2305	Energy Counter Unit

The energy counter unit gives the unit for the value of the Energy Counter.

- 0 = kWh
- 1 = MWh
- 2 = GWh
- 3 = TWh
- 4 = PWh

Example

If the value 4500 is received from ID 2291, the value 42 from ID 2303, and the value 0 from ID 2305, the result is 45.00 kWh.

12.4.6 Energy Trip Counter

The energy trip counter counts the quantity of energy that the drive gets from the supply network. The counter is in the submenu Trip counters. It is possible to reset the counter with the PC, the control panel, or the fieldbus. To read the value of the counter through fieldbus, use these ID numbers.

ID number	Counter value
ID 2296	Energy Trip Counter

The value has always 4 digits. The format and the unit of the counter change to agree with the energy trip counter value. See the following example. It is possible to monitor the energy counter format and unit with ID 2307 Energy Trip Counter Format and ID 2309 Energy trip Counter unit.

Example

- 0.001 kWh
- 0.010 kWh
- 0.100 kWh
- 1.000 kWh

- 10.00 kWh
- 100.0 kWh
- 1.000 MWh
- 10.00 MWh
- 100.0 MWh
- 1.000 GWh
- and so on

ID number	Counter value
ID 2307	Energy Trip Counter Format

The energy trip counter format gives the position of the decimal point in the value of the Energy Trip Counter.

- 40 = 4 digits, 0 fractional digits
- 41 = 4 digits, 1 fractional digit
- 42 = 4 digits, 2 fractional digits
- 43 = 4 digits, 3 fractional digits

Example

- 0.001 kWh (Format = 43)
- 100.0 kWh (Format = 41)
- 10.00 MWh (Format = 42)

ID number	Counter value
ID 2309	Energy Trip Counter Unit

The energy trip counter unit gives the unit for the value of the Energy Trip Counter.

- 0 = kWh
- 1 = MWh
- 2 = GWh
- 3 = TWh
- 4 = PWh

ID number	Counter value
ID 2312	Energy Trip Counter Reset

To reset the energy trip counter, use the PC, the control panel, or the fieldbus. When using the PC or the control panel, reset the counter in the Diagnostics menu. When using the fieldbus, set a rising edge to ID 2312 Energy Trip Counter Reset.

Index

A

Acc/Dec Prohibit (ID 415).....	197	Bandwidth Delay (ID 1098).....	260
Acceleration Time 1 (ID 103).....	186	Baseline Data Element 1 (ID 3601).....	147
Acceleration Time 2 (ID 502).....	187	Baseline Data Element 10 (ID 3610).....	148
Active Faults submenu.....	120	Baseline Data Element 2 (ID 3602).....	148
Adding items in Favourites.....	132	Baseline Data Element 3 (ID 3603).....	148
Additional resources.....	11	Baseline Data Element 4 (ID 3604).....	148
Advanced Harmonic Filter.....	115	Baseline Data Element 5 (ID 3605).....	148
Advanced Sensorless Control.....	163	Baseline Data Element 6 (ID 3606).....	148
AHF Fault Response (ID 15512).....	272	Baseline Data Element 7 (ID 3607).....	148
AHF Over Temperature (ID 15513).....	200, 200	Baseline Data Element 8 (ID 3608).....	148
AI Low (ID 723).....	228	Baseline Data Element 9 (ID 3609).....	148
AI1 Custom. MAX (ID 381).....	202	Baseline Data Selector (ID 3509).....	275
AI1 Custom. MIN (ID 380).....	202	Baseline Run Status (ID 3621).....	148
AI1 Signal Filter Time (ID 378).....	200	BaselineRun Duration (ID 3504).....	274
AI1 Signal Inversion (ID 387).....	203	BaselineRun MaxFreq (ID 3503).....	274
AI1 Signal Range (ID 379).....	201	BaselineRun MinFreq (ID 3502).....	274
AI1 Signal Selection (ID 377).....	200	BaselineRun Start (ID 3501).....	274
Alarm Limit 1 (ID 741).....	225	Basic I/O.....	124
Alarm Limit 2 (ID 764).....	225	Basic monitoring.....	64
Ambient Temperature (ID 705).....	217	Basic monitoring parameters.....	64
Analog Input 1 (ID 59).....	137	Block Out.1 (ID 15020).....	147
Analog Input 2 (ID 60).....	137	Block Out.10 (ID 15200).....	147
Analog Input 3 (ID 61).....	138	Block Out.2 (ID 15040).....	147
Analog Input 4 (ID 62).....	138	Block Out.3 (ID 15060).....	147
Analog Input 5 (ID 75).....	138	Block Out.4 (ID 15080).....	147
Analog Input 6 (ID 76).....	138	Block Out.5 (ID 15100).....	147
Analog Input Low Fault (ID 700).....	226	Block Out.6 (ID 15120).....	147
Analog Input Low Protection (ID 767).....	225	Block Out.7 (ID 15140).....	147
AO1 Filter Time (ID 10051).....	209	Block Out.8 (ID 15160).....	147
AO1 Function (ID 10050).....	208	Block Out.9 (ID 15180).....	147
AO1 Minimum (ID 10052).....	209	Brake Closing Frequency Limit (ID 1539).....	267
AO1 Minimum Scale (ID 10053).....	209, 209	Brake Control (ID 1541).....	266
Application (ID 212).....	151	Brake Current Limit (ID 1085).....	268
Application settings.....	98	Brake Fault Delay (ID 352).....	268
Application Status Word 1 (ID 89).....	139	Brake Feedback (ID 1210).....	268
Application Status Word 2 (ID 90).....	139	Brake Mechanical Delay (ID 1544).....	267, 267
Applications.....	29, 282		
Assign to Channel (ID 1468).....	233	C	
Assign to Channel (ID 1490).....	234	C/F Selection (ID 1197).....	229
Auto-Cleaning.....	268	Capacitor Disconnection Hysteresis (ID 15511).....	272
Auto-Cleaning Activation (ID 1715).....	199	Capacitor Disconnection Limit (ID 15510).....	272
Autochange (ID 1027).....	259	Changing control place.....	26
Autochange (ID 1114).....	142	Changing items to monitor.....	62
Autochange Interval (ID 1029).....	260	Changing rotation direction.....	22, 27
Autochange: Frequency Limit (ID 1031).....	260	Changing the access code.....	133
Automatic reset.....	97	Changing the control place.....	21
Automatic Reset (ID 731).....	227	Channel 1 MAX (ID 2370).....	151
Automatic Torque Boost (ID 109).....	161	Channel 1 MIN (ID 2369).....	151
Automatic Tuning of the U/f Curve.....	285	Channel 2 MAX (ID 2372).....	151
Autoreset: EXT PID Supervision Fault (ID 777).....	229	Channel 2 MIN (ID 2371).....	151
Autoreset: External Fault (ID 726).....	228	Clean Forward Frequency (ID 1717).....	269, 269
Autoreset: Motor Overtemperature (ID 725).....	228	Clean Reverse Frequency (ID 1719).....	269
Autoreset: PID Supervision Fault (ID 776).....	229	Clean Reverse Time (ID 1720).....	269
Autoreset: Underload Fault (ID 738).....	229	Cleaning Acceleration Time (ID 1721).....	269
Autoreset: Unit Overtemperature (ID 724).....	228	Cleaning Activation (ID 1715).....	269
Autoscale (ID 2373).....	152	Cleaning Cycles (ID 1716).....	269
		Cleaning Deceleration Time (ID 1722).....	269
		Cleaning Function (ID 1714).....	269
		Compare parameters.....	132
		Comparing parameters.....	23
		Condition-based Monitoring.....	71, 273, 273
B			
Back-up parameters.....	131		
Bandwidth (ID 1097).....	260		

Condition-based Monitoring Fault Mode (ID 3540).....	275	Duration (ID 1489).....	233
Condition-based Monitoring parameters.....	115	E	
Condition-based Monitoring Status (ID 3619).....	150	Earth Fault (ID 703).....	216
Control Mode (ID 600).....	153	Editing an interval.....	232
Control page.....	21, 27	Editing numerical values.....	19, 25
Control places.....	20, 20	Editing text values.....	19, 25
Control Signal 1 A (ID 403).....	195	Enable DI Jogging (ID 532).....	184
Control Signal 1 B (ID 423).....	195	Enable External PID (ID 1630).....	250
Control Signal 2 A (ID 404).....	195	Enable Feedback Supervision (ID 735).....	241
Control Signal 2 B (ID 424).....	196	Enable Overpressure Supervision (ID 1698).....	261
Control Signal 3 A (ID 434).....	195	Enable Setpoint 1 (ID 1189).....	243
Control Signal 3 B (ID 435).....	196	Enable Setpoint 2 (ID 1191).....	244
Copying the parameters.....	23	Enable Soft Fill (ID 1094).....	245
Counter 1 Alarm Limit (ID 1105).....	262	Enable Supervision (ID 1659).....	253
Counter 1 DI Reset (ID 490).....	262	Enable Supervision (ID 1685).....	248
Counter 1 Fault Limit (ID 1106).....	262	Energy Counter.....	316
Counter 1 Mode (ID 1104).....	262	Energy Optimization (ID 666).....	156
Counter 1 Reset (ID 1107).....	262	Energy Trip Counter.....	317
Current Alarm High Threshold (ID 3613).....	149	Error Inversion (ID 1636).....	251
Current Alarm/Fault Counter (ID 3543).....	278	Error Inversion (ID 340).....	234
Current Alarm/Fault Delay (ID 3524).....	278	External Fault Close (ID 405).....	196
Current Alarm/Fault High (ID 3523).....	278	External Fault Open (ID 406).....	196
Current Alarm/Fault Mode (ID 3522).....	278	External PID controller.....	107
Current Interpolation Type (ID 3515).....	276	External PID controller monitoring.....	68
Current Max Factor (ID 3513).....	276	External PID Setpoint Selection (ID 1048).....	198
Current Mean Factor (ID 3511).....	276	External PID Start Signal (ID 1049).....	198
Current Min Factor (ID 3512).....	276	EXTPID Error (ID 85).....	142
Current Std Factor (ID 3514).....	276	EXTPID Feedback (ID 84).....	142
Current Unbalance (ID 3617).....	148	EXTPID Setpoint (ID 83).....	141
Current Unbalance Threshold Value (ID 3620).....	148	EXTPID Status (ID 86).....	142
Current Warning S1 Counter (ID 3541).....	278	EXTPID Status (ID 87).....	142
Current Warning S1 Delay (ID 3518).....	277	Extras and advanced.....	66
Current Warning S1 High (ID 3517).....	277	F	
Current Warning S1 High Threshold (ID 3611).....	149	Fault history.....	121, 121, 121
Current Warning S1 Mode (ID 3516).....	277	Fault Limit 1 (ID 742).....	225
Current Warning S2 Counter (ID 3542).....	278	Fault Limit 2 (ID 765).....	225
Current Warning S2 Delay (ID 3521).....	277	Fault Limit Response 1 (ID 740).....	225
Current Warning S2 High (ID 3520).....	277	Fault Limit Response 2 (ID 766).....	225
Current Warning S2 High Threshold (ID 3612).....	149	Fault Reset Close (ID 414).....	196
Current Warning S2 Mode.....	277	Fault Reset Open (ID 213).....	196
D		Fault Simulation (ID 1569).....	229
Days (ID 1466).....	233	Fault tracing.....	288
DC Brake Current (ID 507).....	188	Favourites menu.....	132
DC Braking Time at Stop (ID 508).....	188	FB Control Word (ID 874).....	142
DC Link Voltage (ID 7).....	135, 135	FB Data IN 1 (ID 876).....	144
Dead Band (ID 1056).....	234	FB Data IN 10 (ID 230).....	145
Dead Band (ID 1637).....	251	FB Data IN 11 (ID 231).....	145
Dead Band Delay (ID 1057).....	235	FB Data IN 12 (ID 232).....	145
Dead Band Delay (ID 1638).....	251	FB Data IN 13 (ID 233).....	145
Deceleration Time 1 (ID 104).....	186	FB Data IN 14 (ID 234).....	145
Deceleration Time 2 (ID 503).....	187	FB Data IN 15 (ID 235).....	145
Default Values of parameters.....	282	FB Data IN 16 (ID 236).....	145
Delay (ID 1662).....	254	FB Data IN 2 (ID 877).....	144
Delay (ID 737).....	242	FB Data IN 3 (ID 878).....	144
Different Motor Types.....	285	FB Data IN 4 (ID 879).....	144
Digital Inputs.....	195	FB Data IN 5 (ID 880).....	144
DIN Status Word 1 (ID 56).....	139	FB Data IN 6 (ID 881).....	145
DIN Status Word 2 (ID 57).....	139	FB Data IN 7 (ID 882).....	145
Drive customizer.....	113	FB Data IN 8 (ID 883).....	145
Drive customizer monitoring.....	70	FB Data IN 9 (ID 229).....	145
Drive info.....	122		
Drive Status Word (ID 43).....	139		

FB Data OUT 1 (ID 866).....	145	Fieldbus Communication Fault Force Delay (ID 751).....	216
FB Data OUT 10 (ID 246).....	146	Fieldbus Control Force (ID 411).....	196
FB Data OUT 11 (ID 247).....	146	Fieldbus Control Reference Selection (ID 122).....	174
FB Data OUT 12 (ID 248).....	146	Fieldbus data mapping.....	90
FB Data OUT 13 (ID 249).....	146	Fieldbus general.....	129, 129
FB Data OUT 14 (ID 250).....	146	Fieldbus General Control Word (ID 861).....	144
FB Data OUT 15 (ID 251).....	146	Fieldbus General Status Word (ID 862).....	144
FB Data OUT 16 (ID 252).....	147	Fieldbus process data monitoring.....	69
FB Data OUT 2 (ID 867).....	145	Fieldbus redundancy.....	130
FB Data OUT 3 (ID 868).....	146	Fieldbus Sign of Actual (ID 888).....	212
FB Data OUT 4 (ID 869).....	146	Fieldbus Start Logic (ID 889).....	172
FB Data OUT 5 (ID 870).....	146	Fire mode.....	111
FB Data OUT 6 (ID 871).....	146	Fire Mode Activation Close (ID 1619).....	199
FB Data OUT 7 (ID 872).....	146	Fire Mode Activation on Close (ID 1619).....	264
FB Data OUT 8 (ID 873).....	146	Fire Mode Activation on Open (ID 1596).....	263
FB Data OUT 9 (ID 245).....	146	Fire Mode Activation Open (ID 1596).....	199
FB DataOut 1 Selection (ID 852).....	210	Fire Mode Counter (ID 1679).....	264
FB DataOut 10 Selection (ID 891).....	211	Fire Mode Frequency (ID 1598).....	263
FB DataOut 11 Selection (ID 892).....	211	Fire Mode Frequency Source (ID 1617).....	263
FB DataOut 12 Selection (ID 893).....	211	Fire Mode Function.....	262
FB DataOut 13 Selection (ID 894).....	212	Fire Mode Password (ID 1599).....	263
FB DataOut 14 Selection (ID 895).....	212	Fire Mode Reverse (ID 1618).....	199, 264, 264
FB DataOut 15 Selection (ID 896).....	212	Fire Mode Run Indication Current (ID 15580).....	264
FB DataOut 16 Selection (ID 897).....	212	Fire Mode wizard.....	61
FB DataOut 2 Selection (ID 853).....	210	Flux Braking (ID 520).....	188
FB DataOut 3 Selection (ID 854).....	210	Flux Braking Current (ID 519).....	188
FB DataOut 4 Selection (ID 855).....	211	Flux Reference (ID 1250).....	165
FB DataOut 5 Selection (ID 856).....	211	Flying Start Options (ID 1590).....	161
FB DataOut 6 Selection (ID 857).....	211	Flying Start Scan Current (ID 1610).....	161
FB DataOut 7 Selection (ID 858).....	211	Frequency Reference.....	173
FB DataOut 8 Selection (ID 859).....	211	Frequency Reference (ID 25).....	135, 135
FB DataOut 9 Selection (ID 890).....	211	Frequency Reference Source (ID 1495).....	139
FB Speed Actual (ID 865).....	144	Frequency to Start DC Braking at Ramp Stop (ID 515).....	188
FB Speed Reference (ID 875).....	144	Frost Protection.....	249
FB Status Word (ID 864).....	143	Frost Protection (ID 1704).....	249, 249
Feedback 1 Maximum (ID 1654).....	253	Frost Protection Frequency (ID 1710).....	249
Feedback 1 Maximum (ID 337).....	237	Frost Protection Temperature (ID 1708).....	249
Feedback 1 Minimum (ID 1653).....	253	Frost Temperature Monitoring (ID 1711).....	250
Feedback 1 Minimum (ID 336).....	237	FUNCT button.....	20, 26
Feedback 1 Source Selection (ID 1652).....	253	FUNCT Button Configuration (ID 1195).....	230
Feedback 1 Source Selection (ID 334).....	237	Functions.....	12
Feedback 2 Maximum (ID 1657).....	253		
Feedback 2 Maximum (ID 339).....	237	G	
Feedback 2 Minimum (ID 1656).....	253	Generator Power Limit (ID 1290).....	158
Feedback 2 Minimum (ID 338).....	237	Generator Torque Limit (ID 1288).....	158
Feedback 2 Source Selection (ID 1655).....	253		
Feedback 2 Source Selection (ID 335).....	237	I	
Feedback Function (ID 1650).....	253	I/f Start (ID 534).....	162
Feedback Function (ID 333).....	237	I/f Start Frequency (ID 535).....	162
Feedback Function Gain (ID 1058).....	237	I/f Start Frequency (ID 536).....	162
Feedback Function Gain (ID 1651).....	253	I/f Start Function.....	162
Feedback Supervision.....	241	I/O A Start/Stop Logic (ID 300).....	166
Feedforward 1 Maximum (ID 1063).....	238	I/O B Control Force (ID 425).....	196
Feedforward 1 Minimum (ID 1062).....	238	I/O B Reference Force (ID 343).....	196
Feedforward 1 Source Selection (ID 1061).....	238	I/O B Start/Stop Logic (ID 363).....	172
Feedforward 2 Maximum (ID 1066).....	239	I/O configuration.....	83
Feedforward 2 Minimum (ID 1065).....	238	I/O Control Reference A Selection (ID 117).....	173
Feedforward 2 Source Selection (ID 1061).....	238	I/O Control Reference B Selection (ID 131).....	173
Feedforward Function (ID 1059).....	237	I/O monitoring.....	65
Feedforward Gain (ID 1060).....	238	Identification (ID 631).....	154
Field Weakening Point Frequency (ID 602).....	160	Include FC (ID 1028).....	257
Fieldbus.....	127	Input Phase Fault (ID 730).....	215, 215
Fieldbus Communication Fault Clear Delay (ID 752).....	216		

Input Pressure (ID 1695)..... 249
 Input Pressure Supervision..... 247
 Interlock Function (ID 1032)..... 256
 Interval 2 (ID 1443)..... 140
 Interval 3 (ID 1444)..... 140
 Interval 4 (ID 1445)..... 140
 Interval 5 (ID 1446)..... 140
 Intervals)..... 231

J

Jockey Function (ID 1674)..... 270
 Jockey Start Level (ID 1675)..... 271
 Jockey Stop Level (ID 1676)..... 271
 Jogging Parameters..... 183
 Jogging Ramp (ID 1257)..... 185
 Jogging reference 1 (ID 1239)..... 185
 Jogging reference 1 Activation (ID 530)..... 184
 Jogging Reference 1 Activation (ID 530)..... 199
 Jogging reference 2 (ID 1240)..... 185
 Jogging reference 2 Activation (ID 531)..... 184
 Jogging Reference 2 Activation (ID 531)..... 199
 Joystick Dead Zone (ID 384)..... 182
 Joystick Parameters..... 182
 Joystick Signal Selection (ID 451)..... 182
 Joystick Sleep Delay (ID 386)..... 183
 Joystick Sleep Zone (ID 385)..... 183

K

Keypad..... 126
 Keypad Control Force (ID 410)..... 196
 Keypad Control Reference Selection (ID 121)..... 174
 Keypad Direction (ID 123)..... 174
 Keypad Reference (ID 184)..... 174
 Keypad Setpoint 1 (ID 1640)..... 252
 Keypad Setpoint 1 (ID 167)..... 235
 Keypad Setpoint 2 (ID 1641)..... 252
 Keypad Setpoint 2 (ID 168)..... 235
 Keypad Stop Button (ID 114)..... 165
 kW/HP Selection (ID 1198)..... 229

L

Last Active Alarm Code (ID 74)..... 140
 Last Active Alarm ID (ID 77)..... 140
 Last Active Alarm ID (ID 94)..... 140
 Last Active Fault Code (ID 37)..... 140
 Last Active Fault ID (ID 95)..... 140
 License parameters..... 132
 Line Freq (ID 1913)..... 275
 Line Freq Hysteresis (ID 1914)..... 275
 Load Alarm High Threshold (ID 3631)..... 149
 Load Alarm Low Threshold (ID 3634)..... 150
 Load Alarm/Fault Counter (ID 3583)..... 281
 Load Alarm/Fault Delay (ID 3580)..... 281
 Load Alarm/Fault High (ID 3579)..... 281
 Load Alarm/Fault Low (ID 3586)..... 281
 Load Alarm/Fault Mode (ID 3578)..... 280
 Load Drooping (ID 620)..... 155
 Load Drooping Mode (ID 1534)..... 156
 Load Drooping Time (ID 656)..... 155
 Load Interpolation Type (ID 3571)..... 277
 Load Max Factor (ID 3569)..... 276
 Load Mean Factor (ID 3567)..... 276

Load Min Factor (ID 3568)..... 276
 Load S1 High Threshold (ID 3629)..... 149
 Load S1 Low Threshold (ID 3632)..... 150
 Load S2 High Threshold (ID 3630)..... 149
 Load S2 Low Threshold (ID 3633)..... 150
 Load Std Factor (ID 3570)..... 277
 Load Threshold Value (ID 3628)..... 149
 Load Warning S1 Counter (ID 3581)..... 281
 Load Warning S1 Delay (ID 3574)..... 280
 Load Warning S1 High (ID 3573)..... 280
 Load Warning S1 Low (ID 3584)..... 281
 Load Warning S1 Mode (ID 3572)..... 280
 Load Warning S2 Counter (ID 3582)..... 281
 Load Warning S2 Delay (ID 3577)..... 280
 Load Warning S2 High (ID 3576)..... 280
 Load Warning S2 Low (ID 3585)..... 281
 Load Warning S2 Mode (ID 3575)..... 280
 Local/Remote (ID 211)..... 165
 Local/Remote application..... 33
 Local/Remote application wizard..... 56
 Lower Limit (ID 1661)..... 254
 Lower Limit (ID 758)..... 242

M

Magnetizing Current (ID 612)..... 154
 Maintenance Counter 1 (ID 1101)..... 142
 Maintenance counters..... 111
 Maintenance Counters..... 261
 Manual Run..... 275
 Manual Tuning of the U/f Curve..... 286
 Manual version..... 11
 Maximum Frequency Reference (ID 102)..... 173
 Mechanical brake..... 113
 Mechanical Brake Feedback (ID 1210)..... 199
 Mechanical Brake Function..... 266
 Menu structure)..... 16
 Minimum Frequency Reference (ID 101)..... 173
 Modified Activation (ID 3505)..... 275
 Modified Array (ID 3506)..... 275
 Modified Point (ID 3507)..... 275
 Modified Value (ID 3508)..... 275
 Monitor menu..... 62
 Monitoring of maintenance counters..... 69
 Motor 1 Interlock (ID 426)..... 198, 261
 Motor 2 Interlock (ID 427)..... 198
 Motor 3 Interlock (ID 428)..... 198
 Motor 4 Interlock (ID 429)..... 198
 Motor 5 Interlock (ID 430)..... 198
 Motor 6 Interlock (ID 486)..... 199
 Motor BEM Voltage (ID 674)..... 158
 Motor Cos Phi (ID 120)..... 153
 Motor Current (ID 3)..... 135, 135
 Motor Current 1 Deci (ID 45)..... 139
 Motor Current Limit (ID 107)..... 158
 Motor Limit (ID 1030)..... 260
 Motor Nominal Current (ID 113)..... 153
 Motor Nominal Frequency (ID 111)..... 152
 Motor Nominal Power (ID 116)..... 153
 Motor Nominal Speed (ID 112)..... 152
 Motor Nominal Voltage (ID 110)..... 152
 Motor Potentiometer application..... 51
 Motor Potentiometer application wizard..... 59
 Motor Potentiometer DOWN (ID 417)..... 181

Motor Potentiometer Down (ID 417).....	197, 197	Overvoltage Control (ID 607).....	156
Motor Potentiometer Parameters.....	181		
Motor Potentiometer Ramp Time (ID 331).....	181	P	
Motor Potentiometer Reset (ID 367).....	182	Parameter Lock Key (ID 1808).....	230
Motor Potentiometer UP (ID 418).....	181	Parameter Set 1/2 Selection (ID 496).....	200
Motor Potentiometer Up (ID 418).....	197	Password (ID 1806).....	229
Motor Power (ID 5).....	135, 135	PID Control application.....	42
Motor Power Limit (ID 1289).....	158	PID Control application wizard.....	57
Motor preheat (ID 1228).....	137	PID controller.....	100
Motor Preheat Current (ID 1227).....	265	PID controller monitoring.....	68
Motor Preheat Function (ID 1225).....	265	PID Derivation Time (ID 132).....	234
Motor Preheat ON (ID 1044).....	265	PID Derivation Time (ID 1633).....	250
Motor preheat parameters.....	112	PID Error (ID 22).....	141
Motor settings.....	73	PID Feedback (ID 21).....	141
Motor shaft power (ID 73).....	136	PID Gain (ID 118).....	234
Motor Shaft Power 1 Decimal (ID 98).....	140	PID Gain (ID 1631).....	250
Motor Speed (ID 2).....	135, 135	PID Integration Time (ID 119).....	234
Motor Stall Fault (ID 709).....	221	PID Integration Time (ID 1632).....	250
Motor Stall Protection.....	220	PID Output (ID 23).....	141
Motor Switch (ID 653).....	154	PID Setpoint (ID 20).....	141
Motor Temperature (ID 9).....	137	PID Setpoint Boost (ID 1046).....	198
Motor Thermal Loadability (ID 708).....	219	PID Setpoint Boost Activation (ID 1046).....	236
Motor Thermal Memory Adjust (ID 778).....	220	PID Setpoint Reduction (ID 1694).....	249
Motor Thermal Protection (ID 704).....	217	PID Setpoint Selection (ID 1047).....	198, 236
Motor Thermal Protections.....	217	PID Soft Fill Fault (ID 748).....	215
Motor Thermal Time Constant (ID 707).....	218	PID Soft Fill Timeout Response (ID 748).....	247
Motor Torque (ID 4).....	135, 135	PID Status (ID 24).....	141
Motor Torque Limit (ID 1287).....	158	Positive Frequency Reference Limit (ID 1285).....	173
Motor Type (ID 650).....	153	Power on Time Counter.....	316
Motor Voltage (ID 6).....	135, 135	Power unit settings.....	126
Motors Running (ID 30).....	142	Preheat Motor Temperature (ID 1045).....	265
Multi-pump.....	110	Preheat Temperature Limit (ID 1226).....	265
Multi-pump function.....	255	Preset Alarm Frequency (ID 183).....	216
Multi-pump monitoring.....	68	Preset Frequencies.....	178
Multi-pump wizard.....	60	Preset Frequency 0 (ID 180).....	179
Multi-purpose application.....	46	Preset Frequency 1 (ID 105).....	179
Multi-purpose application wizard.....	58	Preset Frequency 2 (ID 106).....	180
Multi-step Speed application.....	37	Preset Frequency 3 (ID 126).....	180
Multi-step Speed application wizard.....	57	Preset Frequency 4 (ID 127).....	180
Multimonitor View (ID 1196).....	230	Preset Frequency 5 (ID 128).....	180
		Preset Frequency 6 (ID 129).....	180
N		Preset Frequency 7 (ID 130).....	180
Negative Frequency Reference Limit (ID 1286).....	173	Preset Frequency Mode (ID 182).....	178
no term text found		Preset Frequency Selection 0 (ID 419).....	180, 197
Number of Motors (ID 1001).....	255	Preset Frequency Selection 1 (ID 420).....	180, 197, 197
Number of Trials (ID 759).....	227	Preset Frequency Selection 2 (ID 421).....	180
		Pressure Loss Compensation.....	243
O		Primary Fieldbus Connection (ID 2607).....	152
OFF Time (ID 1465).....	233	Priming Function (ID 1677).....	272, 272
ON Time (ID 1464).....	233	Priming Pump.....	271
Open Loop Torque Control I Gain (ID 640).....	178	Process Unit Decimals (ID 1035).....	234
Open Loop Torque Control Minimum Frequency (ID 636).....	177	Process Unit Decimals (ID 1666).....	251
Open Loop Torque Control P Gain (ID 639).....	177	Process Unit MAX (ID 1034).....	234
Operating Time Counter.....	314	Process Unit Max (ID 1665).....	250
Operating Time Trip Counter.....	315	Process Unit Min (ID 1664).....	250
Operation Mode (ID 15001).....	266	Process Unit Selection (ID 1036).....	234, 234
Option board slots.....	124	Process Unit Selection (ID 1635).....	250
Output Frequency (ID 1).....	135, 135	Programmable Inputs	
Output in Stop (ID 1100).....	250	Default functions.....	195
Overcurrent (ID 722).....	228	Programming of Analog Inputs.....	192, 193, 194
Overmodulation (ID 1515).....	157	Programming of Digital Inputs.....	189, 191, 191
Overvoltage (ID 721).....	228	Programming of inputs.....	188
		Prohibit frequencies.....	92

Prohibit Frequencies Function.....212
 Prohibit Frequency Range 1 High Limit (ID 510).....213
 Prohibit Frequency Range 1 Low Limit (ID 511).....213
 Prohibit Frequency Range 1 Low Limit (ID 509).....212
 Prohibit Frequency Range 2 High Limit (ID 512).....213
 Prohibit Frequency Range 3 High Limit (ID 514).....213
 Prohibit Frequency Range 3 Low Limit (ID 513).....213
 Protections.....93
 Pump control.....114

Q

Qualified personnel..... 11
 Quick Stop Deceleration Time (ID 1256)..... 223
 Quick Stop Mode (ID 1276)..... 223, 223

R

Ramp 1 Shape (ID 500).....185
 Ramp 2 Selection (ID 408)..... 187, 197
 Ramp 2 Shape (ID 501).....186
 Reading help texts..... 24
 Ready Status (ID 78).....139
 Real-time clock.....125
 Real-time Clock (ID 1450).....141
 Redundancy Mode (ID 2606).....152
 References.....77
 Remote Control Place (ID 172).....165
 Remote to Local Function (ID 181).....173
 Removing items from Favourites.....132
 Reset faults.....120, 120, 120, 120
 Reset Maintenance Counter (ID 490).....199, 199
 Resetting a fault.....20, 20
 Response to Brake Fault (ID 1316).....268
 Response to External Fault (ID 701).....215
 Response to External PID Supervision Fault (ID 757).....216, 254
 Response to Fieldbus Communication Fault (ID 733).....215
 Response to Fieldbus Redundant Control Switchover (ID 750).....216
 Response to Output Phase Fault (ID 702).....215
 Response to PID Supervision Fault (ID 749).....216, 243
 Response to Quick Stop Fault (ID 744).....223
 Response to Safe Torque Off (STO) Fault (ID 775).....216
 Response to User Defined Fault 1 (ID 15525).....226
 Response to User Defined Fault 2 (ID 15526).....227
 Restart Function (ID 719).....227
 RO1 Function (ID 11001).....204, 207
 RO1 OFF Delay (ID 11003).....207
 RO2 Function (ID 11004).....207
 RO2 OFF Delay (ID 11006).....207
 RO2 ON Delay (ID 11005).....207
 RO3 Function (ID 11007).....207
 RO3 OFF Delay (ID 11009).....207
 RO3 ON Delay (ID 11008).....207
 Run Enable (ID 407).....196
 Run Interlock 1 (ID 1041).....196
 Run Interlock 2 (ID 1042).....197, 197
 Run Time Counter.....315

S

Sampling Interval (ID 2368).....151
 Secondary Fieldbus Connection (ID 2608).....152
 Select Setpoint (ID 1048).....252
 Selecting more than 1 value.....20
 Sensorless Control (ID 1724).....164

Sensorless Control Options (ID 1726).....164
 Sensorless Torque Control I Gain (ID 1732).....178
 Sensorless Torque Control P Gain (ID 1731).....178
 Set Parameter Lock (ID 1807).....230
 Setpoint 1 Boost (ID 1071).....236
 Setpoint 1 Maximum (ID 1070).....236
 Setpoint 1 Maximum (ID 1645).....252
 Setpoint 1 Minimum (ID 1069).....236
 Setpoint 1 Minimum (ID 1644).....252
 Setpoint 2 Boost (ID 1078).....236
 Setpoint 2 Maximum (ID 1074).....236
 Setpoint 2 Maximum (ID 1648).....252
 Setpoint 2 Minimum (ID 1073).....236
 Setpoint 2 Minimum (ID 1647).....252
 Setpoint Ramp Time (ID 1068).....235
 Setpoint Ramp Time (ID 1642).....252
 Setpoint Source 1 Selection (ID 1643).....252
 Setpoint Source 1 Selection (ID 332).....236
 Setpoint Source 2 Selection (ID 1646).....252
 Setpoint Source 2 Selection (ID 431).....236
 Signal Sources.....194
 Simple Network Time Protocol.....125
 Slot Communication Fault (ID 734).....215
 SlotA AO1 (ID 81).....138
 SlotA DIN 1,2,3 (ID 15).....137
 SlotA DIN 4,5,6 (ID 16).....137
 SlotB RO 1,2,3 (ID 17).....137
 Soft Fill.....245
 Soft Fill Frequency (ID 1055).....245
 Soft Fill Level (ID 1095).....246
 Soft Fill Timeout (ID 1096).....246
 Software info.....122
 SP1 Sleep Delay (ID 1017).....239
 SP1 Sleep Frequency (ID 1016).....239
 SP1 Wake-Up Level (ID 1018).....239
 SP1 Wake-Up Mode (ID 1019).....239
 SP2 Sleep Delay (ID 1076).....240
 SP2 Sleep Frequency (ID 1075).....240
 SP2 Wake-Up Level (ID 1077).....240
 SP2 Wake-Up Mode (ID 1020).....241
 Speed Control Gain (ID 1733).....165
 Speed Control Time (ID 1734).....165
 Stall Current (ID 710).....221
 Stall Frequency Limit (ID 712).....221
 Stall Time Limit (ID 711).....221
 Standard application.....29
 Standard application wizard.....56
 Start and Stop Commands.....165
 Start Delay (ID 524).....173
 Start Function (ID 505).....166
 Start Magnetizing Current (ID 517).....187
 Start Magnetizing Time (ID 516).....187
 Start Signal (ID 1049).....250
 Start-up quick guide.....13
 Start-up wizard.....13
 Start/Stop setup.....76
 Startup Prevented Fault (ID 15593).....216
 Stator Inductance Voltage Drop (ID 673).....158
 Stator Resistance Voltage Drop (ID 662).....157
 Stator Voltage Adjust (ID 659).....156
 Stator Winding Monitoring.....275
 STO.....130
 Stop Function (ID 506).....166

Supervision #1 Item Selection (ID 1431).....	214	Torque Stabilator Damping Time Constant for PM Motors (ID 1735).....	163
Supervision #1 Limit (ID 1433).....	214	Torque Stabilator Filter Time Constant (ID 15650).....	163
Supervision #1 Limit Hysteresis (ID 1434).....	214	Torque Stabilator Filter Time Constant for PM Motors (ID 15651).....	163
Supervision #1 Mode (ID 1432).....	214	Torque Stabilator Gain (ID 1412).....	162
Supervision #2 Item Selection (ID 1435).....	214	Torque Stabilator Gain at Field Weakening Point (ID 1414).....	163
Supervision #2 Limit (ID 1437).....	215	Total and Trip Counters.....	314
Supervision #2 Limit Hysteresis (ID 1438).....	215	Trend curve.....	62, 62, 63
Supervision #2 Mode (ID 1436).....	214	Trend curve parameters.....	64
Supervision Alarm Level (ID 1691).....	248	Trial Time (ID 718).....	227
Supervision Alarm Level (ID 1699).....	261		
Supervision Fault Delay (ID 1693).....	249	U	
Supervision Fault Level (ID 1692).....	249	U/f Midpoint Voltage (ID 605).....	161
Supervision Signal (ID 1686).....	248	U/F Ratio (ID 108).....	159
Supervision Unit Decimals (ID 1688).....	248	Unbalance Current Alarm (ID 753).....	217
Supervision Unit Maximum Value (ID 1690).....	248	Underload Fault (ID 713).....	222
Supervision Unit Minimum Value (ID 1689).....	248	Underload Protection.....	221
Supervision Unit Selection (ID 1687).....	248	Underload Protection: Field Weakening Area Load (ID 714).....	222
Supervisions.....	92	Underload Protection: Time Limit (ID 716).....	222
Switchback Timeout (ID 2612).....	152	Underload Protection: Zero Frequency Load (ID 715).....	222
Switching Frequency (ID 601).....	153	Undervoltage (ID 720).....	228
Switchover Counter (ID 2611).....	152	Undervoltage Control (ID 608).....	156
Switchover Timeout (ID 2609).....	152	Unit status.....	123
		Unit Temperature (ID 8).....	136, 136
T		Upper Limit (ID 1660).....	254
TC 1, TC 2, TC 3 (ID 1441).....	140	Upper Limit (ID 736).....	242
TC 1, TC 2, TC 3 (ID 1442).....	140	User Defined Fault 1 (ID 15523).....	200, 200, 200, 200
Temperature input (ID 71).....	138	User Defined Fault 2 (ID 15524).....	200, 200, 200, 200
Temperature input 1 (ID 50).....	138	User level menu.....	133
Temperature input 2 (ID 51).....	138	User level parameters.....	133
Temperature input 3 (ID 52).....	138	User settings.....	131
Temperature input 4 (ID 69).....	138	Using Quick Edit function.....	22, 22
Temperature input 5 (ID 70).....	138	Using the Favourites menu.....	25
Temperature inputs.....	65, 138		
Temperature Signal 1 (ID 739).....	224	V	
Temperature Signal 2 (ID 763).....	225	VACON® Live.....	28
Temperature Signal Maximum (ID 1707).....	249	Vibration (ID 3623).....	149
Temperature Signal Minimum (ID 1706).....	249	Vibration Alarm High Threshold (ID 3627).....	149
Thermistor Fault (ID 732).....	215	Vibration Alarm/Fault Counter (ID 3566).....	280
Threshold Value.....	275	Vibration Alarm/Fault Delay (ID 3563).....	279
Time channels.....	230	Vibration Alarm/Fault High (ID 3562).....	279
Timer 1 (ID 1447).....	141	Vibration Alarm/Fault Mode (ID 3561).....	279
Timer 1 (ID 447).....	197, 233	Vibration Input (ID 3587).....	281
Timer 2 (ID 1448).....	141	Vibration Interpolation Type (ID 3554).....	276
Timer 2 (ID 448).....	198	Vibration Max Factor (ID 3552).....	276
Timer 3 (ID 1449).....	141	Vibration Mean Factor (ID 3550).....	276
Timer 3 (ID 449).....	198	Vibration Min Factor (ID 3551).....	276
Timer functions.....	98	Vibration S1 High Threshold (ID 3625).....	149
Timer Functions.....	230	Vibration S2 High Threshold (ID 3626).....	149
Timer functions monitoring.....	67	Vibration Std Factor (ID 3553).....	276
Timers.....	231	Vibration Threshold Value (ID 3624).....	149
Torque Boost Generator Gain (ID 665).....	162	Vibration Warning S1 Counter (ID 3564).....	279
Torque Boost Motor Gain (ID 667).....	161	Vibration Warning S1 Delay (ID 3557).....	279
Torque Control Frequency Limit (ID 1278).....	176	Vibration Warning S1 High (ID 3556).....	278
Torque Maximum Reference (ID 642).....	176	Vibration Warning S1 Mode (ID 3555).....	278
Torque Minimum Reference (ID 643).....	176	Vibration Warning S2 Counter (ID 3565).....	280
Torque Reference.....	174	Vibration Warning S2 Delay (ID 3560).....	279
Torque Reference (ID 18).....	137	Vibration Warning S2 High (ID 3559).....	279
Torque Reference Dead Zone (ID 1246).....	176	Vibration Warning S2 Mode (ID 3558).....	279
Torque Reference Dead Zone (ID 1439).....	176	Voltage at Field Weakening Point (ID 603).....	160, 160
Torque Reference Filter Time (ID 1244).....	176		
Torque Reference Selection (ID 641).....	175		
Torque Stabilator Damping Time Constant (ID 1413).....	163		

W		Z	
Wait Time (ID 717).....	227	Zero Frequency Voltage (ID 606).....	161
Warning and Alarm/Fault Stages.....	277	Zero Speed Cooling Factor (ID 706).....	217
Wizards in Menu 1.1.....	59		

ENGINEERING
TOMORROW

Danfoss

**Vacon Ltd, Member of the
Danfoss Group**
Runsorintie 7
FIN-65380 Vaasa
www.danfoss.com

Danfoss can accept no responsibility for possible errors in catalogs, brochures and other printed material. Danfoss reserves the right to alter its products without notice. This also applies to products already on order provided that such alterations can be made without subsequential changes being necessary in specifications already agreed. All trademarks in this material are property of the respective companies. Danfoss and the Danfoss logotype are trademarks of Danfoss A/S. All rights reserved.

