

Contents

1. Introduction to VLT 3000 to VLT FC 302 Converter	3
Introduction to VLT 3000 to VLT FC 302 Converter	3
Software version	3
Introduction	3
Configuration	3
Setup up of the converter software	4
Bus Connection	4
Mapping List	6

1. Introduction to VLT 3000 to VLT FC 302 Converter

1.1. Introduction to VLT 3000 to VLT FC 302 Converter

1.1.1. Software version

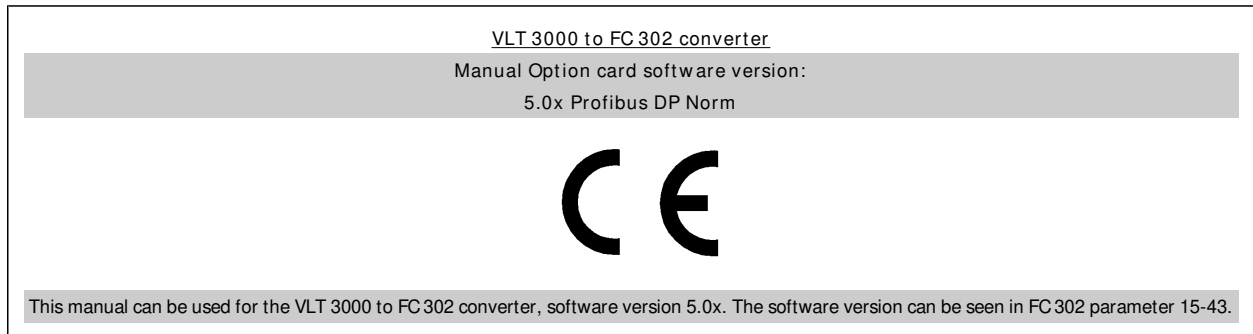

1.1.2. Introduction

This VLT 3000 to FC 302 converter is a tool intended for the conversion of a VLT 3000 to a FC 302, which replaces the VLT 3000. The conversion is possible for all VLT 3000's with the serial numbers from XXXXXXG265. To purchase (obligatory): - FC 302 130B1245 - with Software version 4.35 or Higher. For Mechanical adaption, several adapter plates are available. For VLT 3002-3004 Compact IP00, ordering number 130B0056. For VLT 3002-3004 Compact IP00 with Brake ordering number 130B0058

Please notify some parameters in the VLT 3000 are not supported in the FC 302 and some FC 302 parameters can not be accessed via the Profibus converter Option.

1.1.3. Configuration

With the Profibus converter software the FC 302 will react on the Profibus network as a VLT 3000; it means that it is not necessary to change anything in the PLC programme. A write command to for example ramp up time in VLT 3000 is automatically linked to the corresponding ramp up time parameter in FC 302.

Please note that the converter software will only work on a Profibus DP Norm network. It will not work on a Sinec L2 or a Siemens DP network. You can check your Profibus network either by the VLT 3000 or by the master.

1

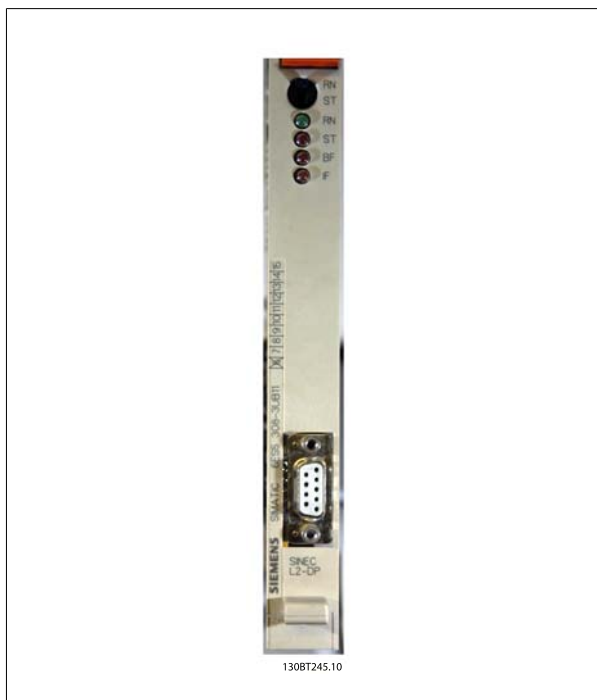

IM 308-B ver. 6 IM 308-C This master supports Profibus DP Norm This master supports Profibus DP Norm

We support Profibus DP Norm by VLT 3000 with a software version that should be higher than version 3.00. The software version number can be read out in parameter 603, choice 3. The master must be a Profibus DP Norm master. If a master from Siemens S5 series is used the master must be an IM-308C or IM-308B and higher or equal to version 6. All Siemens S7 series are Profibus DP Norm.

1.1.4. Setup up of the converter software

Before VLT 3000 can be replaced with a FC302 only the station address needs to be setup in the FC 302. Ensure that the parameters in the below table have the same setting in FC 302 as in VLT 3000.

VLT 3000	FC 302
Par. 820 Baud Rate	Autodetect (see par. 963)
Par. 904 PPO type	Autodetect (see par. 922)
Par. 918 Station Address	Par. 918 Station Address or via DIP switch

Table 1.1: Settings

After copying the station address from the VLT 3000 to the FC 302, power must be re-cycled to the FC 302 as this parameter is only valid after power up. The master should now recognize FC302. The two LEDs in the front of the Profibus card should now be solid green which indicates that communication between master and slave is established.

If the Net Status LED flashes, the master has not recognized the FC 302. Check if Baud rate, PPO type and station address are the same in the FC 302 as the VLT 3000.

1.1.5. Bus Connection



NB!
VLT 5000 has other physical connections compared to VLT 3000.

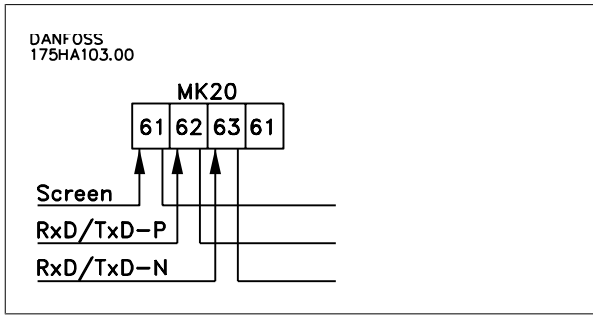

Illustration 1.1:

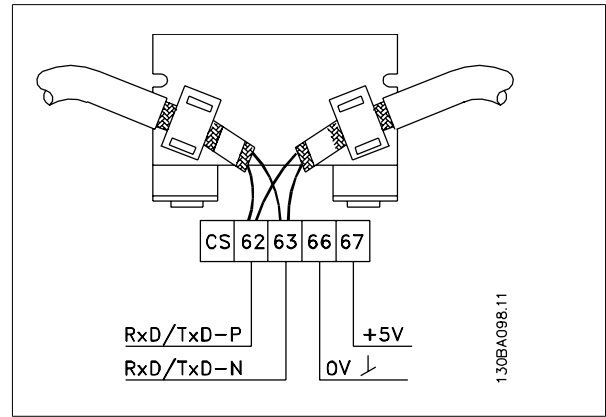



Illustration 1.2:

RPM



NB!
The VLT 3000 converter sets Parameter 0-02 to Hz mode at power-up. This is done to secure proper operation of the converter software. The user should not change this, since it would lead to malfunction of the system.

Digital Inputs 16/ 17



NB!
The FC 302 has a reduced number of Digital I/O compared to the VLT 3000. If all inputs of the VLT 3000 are being used, an additional option board MCB 101 is needed. The MCB 101 adds Digital input and Outputs to the FC 302.

Current/ Voltage Selection on Analog Inputs



NB!
The VLT 3000 has two analogue inputs - one voltage and one current. The FC 302 has two analogue inputs, which can be set to *Current* and *Voltage* via two small DIP switches on the control card. Factory setting is *Voltage* in both cases.

1.1.6. Mapping List

1

The below listed VLT 3000 parameters in the left column have the corresponding FC 302 parameters as shown in the right column. Please be notify that the opposite is not the case. the FC 302 series using the LCP.

VLT 3000		FC300	
Par. no	Par. Name	Par. no	Par. Name
000	Language Select	001	Language
001	Set-up Selection, Operation	010	Active Set-up
002	Setup Copy	051	Setup Copy
003	Operation Site		No valid parameter
004	Local Reference		No valid parameter
005	Display Value		No valid parameter
006	Local reset	043	Local reset of Trip
007	Local Stop	041	Off (Stop)
008	Local Reversing		No valid parameter
009	Local Jogging		No valid parameter
010	Local Reference		No valid parameter
011	Reset Energy Counter	1506	Reset of kWh Counter
012	Reset Hour Counter	1507	Reset of Hours-Run Counter
014	Power-up Mode	004	Operating State at Power-up, Hand
015	Set-up Selection, Programming	970	Edit Set-up
100	Load	103	Torque Characteristics
101	Speed Control	100	Configuration
102	Current Limit Control	420	Torque Limit Factor Source
103	Motor Power	120	Motor Power
104	Motor Voltage	122	Motor Voltage
105	Motor Frequency	123	Motor Frequency
106	Automatic Motor Adaptation		No valid parameter
107	Motor Current	124	Motor Current
108	Motor Magnetising Current		No valid parameter
109	Start Voltage		No valid parameter
110	Start Compensation		No valid parameter
111	U/f ratio		No valid parameter
112	Slip Compensation		No valid parameter

Table 1.2: Mapping List

1

VLT 3000		FC 300	
Par. no	Par. Name	Par. no	Par. Name
113	Negative Slip Compensation		No valid parameter
114	Feedback Type	720	Process CL Feedback 1 Resource
115	Display Value at min. Feedback		No valid parameter
116	Display Value at max. Feedback		No valid parameter
117	Feedback Unit	301	Reference/feedback Unit
119	Feed Forward Factor	738	Process PID Feed Forward Factor
120	Controller Range		No valid parameter
121	Proportional Gain	733	Process PID Proportional Gain
122	Integral Time	734	Process PID Integral Time
123	Differentiation Time	735	Process PID Differentiation Time
124	Low Pass Filter	616, 626	Terminal 53, 54 Filter Time Constant
125	Feedback Factor		No valid parameter
200	Frequency Range	410	Output Frequency Range/Direction
201	Min. Frequency	302, 412	302 Min. reference 412 Motor speed Low Limit, Hz 614 Terminal 53 Low ref value 624 Terminal 54 Low ref value
202	Max. Frequency	303, 414	303 Max. reference 414 Motor speed high Limit, Hz 615 Terminal 53 High ref value 625 Terminal 54 High ref value
203	Jog Frequency	311	Jog speed
204	Digital Reference Type	304	Reference function
205	Digital Reference 1	310 index 0	Preset Reference 1..8
206	Digital Reference 2	310 index 1	Preset Reference 1..8
207	Digital Reference 3	310 index 2	Preset Reference 1..8
208	Digital Reference 4	310 index 3	Preset Reference 1..8

Table 1.3: Mapping List

VLT 3000		FC300	
Par. no	Par. Name	Par. no	Par. Name
209	Current Limit	418	Current Limit
210	Warning Frequency Low	452	Warning: Low Speed
211	Warning Frequency High	453	Warning: High Speed
212	Warning Current Low	450	Warning Current Low
213	Warning Current High	451	Warning: High Current
214	Ramp Type	340	Ramp Type
		350	
215	Ramp-Up Time 1	341	Ramp-Up Time 1
216	Ramp-Down Time 1	342	Ramp-Down Time 1
217	Ramp-Up Time 2	351	Ramp-Up Time 2
218	Ramp-Down Time 2	352	Ramp-Down Time 2
219	Frequency Bypass 1	461	Frequency Bypass 1
		index 0	
220	Frequency Bypass 2	461	Frequency Bypass 2
		index 1	
221	Frequency Bypass 3	461	Frequency Bypass 3
		index 2	
222	Frequency Bypass 4	461	Frequency Bypass 4
		index 3	
223	Frequency Bypass Bandwidth	Store to EEPROM value	Frequency Bypass Bandwidth
224	Carrier Frequency	1401	Switching Frequency
225	Output Frequency		No valid parameter
230	Brake Out-Out Frequency		
231	Brake Cut-In Frequency	222	Activate Brake Speed [Hz]
232	Current, Minimum Value	176	Start Current
233	Current, Delay Time	171	Start Delay
300	Brake Option	210	Brake Function
301	Start Frequency	175	Start Frequency
302	Start Delay	171	Start Delay
303	High Starting Torque		No valid parameter

Table 1.4: Mapping List

VLT 3000

FC-300

Par. no	Par. Name	Par. no	Par. Name
304	Mains Failure		No valid parameter
305	Flying Start	173	Flying Start
306	DC Braking Time	202	DC Braking Time
307	DC Brake Cut-in Frequency at Stop	204	DC Brake Cut-in Frequency
308	DC Brake Voltage		No valid parameter
309	Reset Mode	1420	Reset Mode
310	Trip Delay at Current Limit	1425	Trip Delay Torque
311	Trip Delay at Inverter Fault	1426	Trip Delay at Inverter Fault
312	Max. Auto Restart Time	1421	Automatic Restart Time
313	Motor Check	180	Function at Stop
314	Motor Preheat	180	Function at Stop
315	Motor Thermal Protection	190	Motor Thermal Protection
316	Relay ON-delay	541 index 0	Relay 01 ON-delay
317	Relay OFF-delay	542 index 0	Relay 01 OFF-delay
400	Binary Input 16	516 (MCB 101)	Terminal X30/2 Digital Input
401	Binary Input 17	517 (MCB 101)	Terminal X30/3 Digital Input
402	Binary Input 18	510	Terminal 18 Input
403	Binary Input 19	511	Terminal 19 Input
404	Binary Input 27	512	Terminal 27 Input
405	Binary Input 29	513	Terminal 29 Input
406	Binary Input 32/33	514 (term. 32), 515 (term. 33)	Terminal 32/33 Input
407	Par. 407 Signal Output 42	Digital = Par. 532 DO X30/6 (MCB 101) Analogue values= Par. 650 AO 42	Digital = Par. 532 DO X30/6 (MCB 101) Analogue values= Par. 650 AO 42

Table 1.5: Mapping List

VLT 3000		FC300	
Par. no	Par. Name	Par. no	Par. Name
408	Par. 408 Signal Output 45	Digital = Par. 533 DO X30/7 (MCB 101) Analogue values= 101)	Digital = Par. 533 DO X30/6 (MCB 101) Analogue values= Par. 660 AO X30/8 (MCB 101)
Par. 409 Relay 1	Relay Output 01 / 04	Par. 540 index 0 Relay 1	Relay 01 and 04 Output
Par. 410 Relay 04		Par. 540 index 1 Relay 2	
411	Analogue Reference Type		No valid parameter
412	Terminal 53, Analogue Input Voltage		No valid parameter
413	Terminal 60, Analogue Input Current		No valid parameter
414	Time Out	600	Time Out
415	Time Out Function	601	Function after Time Out
500	Address	831	Address
501	Baud Rate	832	Baud Rate
502	Data Read Out		No bus access via Profibus
503	Coasting	850	Coasting
504	Q-stop	851	Quick Stop
505	DC brake	852	DC brake
506	Start	853	Start
507	Direction	854	Reversing
508	Reset		No valid parameter
509	Set-up Select	855	Selection of Set-up
510	Digital Speed Select	856	Preset ref. select
511	Bus Jogging 1	890	Bus Jog 1
512	Bus Jogging 1	891	Bus Jog 2
513	Catch-up/Slow-down Value	312	Catch-up/Slow-down Value

Table 1.6: Mapping List

VLT 3000		FC 300	
Par. no	Par. Name	Par. no	Par. Name
514	Bus Bit 4		No valid parameter
515	Bus Bit 11/12		No valid parameter
516	Bus Reference		No valid parameter
517	Store Data Values	971	Store Data Values
600	Total Operating Hours	1500	Operating Data: Operating Hours
Index 0			
600	Running Hours	1501	Operating Data: Hours Run Hours
Index 1			
600	kWh counter	1502	Operating Data: kWh Counter
Index 2			
600	Number of Out-ins	1503	Operating Data: Number of Power-ups
Index 3			
600	Number of Overheatings	1504	Operating Data: Number of Overtemperatures
Index 4			
600	Number of Overvoltages	1505	Operating Data: Number of Overvoltages
Index 5			
605	Personal Display Select	23	Display Line 2 Large
800	Data read-out: Reference %	1602	Data Read-Out: Reference %s
801	Data read-out: Frequency Hz	1613	Data read-out: Frequency Hz
802	Data read-out: Feedback	1652	Data Read-Out: Feedback (unit)
803	Data read-out: Current A	1614	Data Read-Out: Current A
804	Data read-out: Torque %	1620	Data Read-Out: Torque %
805	Data read-out: Power kW	1610	Data Read-Out: Power kW
806	Data read-out: Power HP	1611	Data Read-Out: Power HP
807	Data read-out: Energy kWh	1502	Operating Data: kWh counter
808	Data read-out: Output Voltage	1612	Data Read-Out: Motor Voltage
809	Data read-out: DC Voltage	1630	Data Read Out: DC Link Voltage
810	Data read-out: Motor Therm %	1618	Data Read-Out: Motor Therm.
811	Data read-out: Inverter Therm %	1635	Data Read-Out: Inv. Therm.
812	Data read-out: Digital Input	1660	Data Read-Out: Digital Input
813	Data read-out: Analogue Input 10V	1662	Data Read-Out: Terminal 53: Analogue Input
814	Data read-out: Analogue Input 20mA	1664	Data Read-Out: Terminal 54: Analogue Input
815	Data read-out: Position		No valid parameter
816	Alarm Parameters	1690	Data Read-Out: Alarm Word

Table 1.7: Mapping List

VLT 3000		FC 300	
Par. no	Par. Name	Par. no	Par. Name
817	Relay 01 Function		No valid parameter
818	Relay 04 Function		No valid parameter
819	SAP Select		No valid parameter
820	Baud Rate Select		No valid parameter
821	FMS/DP Select		No valid parameter
822	Minimum Station Delay		No valid parameter
823	Bus Time Out	803	Bus Time Out
824	Time Out Function	804	Bus Time Out Function <i>Of functionality from parameter 823.</i>
900	PPO Write Type 1		No valid parameter
901	PPO Write Type 2		No valid parameter
902	PPO Write Type 3		No valid parameter
903	PPO Write Type 4		No valid parameter
904	PPO Type Select		No valid parameter
907	Read PPO Type 1		No valid parameter
908	Read PPO Type 2		No valid parameter
909	Read PPO Type 3		No valid parameter
910	Read PPO Type 4		No valid parameter

Table 1.8: Mapping List

VLT 3000		FC-300	
Par. no	Par. Name PPO Read Type	Par. no	Par. Name
911			No valid parameter
913	Broadcast Index		No valid parameter
914	Broadcast Offset		No valid parameter
915	Assign parameter numbers to PCD's write	Not supported	
916	Assign parameter numbers to PCD's Read	Not supported	PCD config. Read
917	Activate Spontaneous/ event Messages		No valid parameter
918	Station Address	918	Station Address
927	Access to Parameter Change	927	Parameter Edit
928	Access to Process Control	928	Process Control
947	Fault Memory	Not supported	
949	Fault Memory	Not supported	
951	Fault list	Not supported	
953	Warning Parameter	1692 and 1694	Data Read Out: Warning Word 1 and extended status word
954	HPPB Warning word	Not supported	
961	No bus access	Not supported	
964	Unit ID	Not supported	
967	Unit ID	Not supported	
968	Unit ID	Not supported	
969	Time difference	Not supported	
964	Unit ID	Not supported	
970	Set-up Selection, Programming	011	Edit Set-up
971	Store Data Values	971	Store Data Values

Table 1.9: Mapping List