

Installation Instructions

Finger Guards

VLT[®] Soft Starter MCD 200/MCD 500

1 Product Overview

These instructions provide information about installation of finger guard kits. The instructions are targeted at users already familiar with the VLT[®] Soft Starters MCD 500, or VLT[®] Compact Starters MCD 200/202. Read the instructions before installation and ensure that instructions for safe installation are observed.

Additional resources

Further manuals and instructions are available for download at vlt-drives.danfoss.com/Support/Technical-Documentation/.

2 Items Supplied

The finger guard is available in different kits depending on model and enclosure size. For a list of all available kit part numbers, refer to *chapter 4.5 Packing List*.

3 Safety Instructions

Finger guards fit over the soft starter power terminals to increase IP rating and prevent accidental contact with live terminals.

WARNING

ELECTRICAL SHOCK HAZARD

VLT[®] Soft Starters contain dangerous voltages when connected to mains voltage.

Models MCD5-0360C ~ MCD5-1600C: The bus bar and heat sink are live while the unit operates (starts, runs, or stops). If the soft starter is installed without a main contactor, the bus bar and heat sink are live whenever mains voltage is connected. This is also the case when the soft starter is ready or tripped.

Improper installation of the motor or the soft starter, and installing or servicing with power connected, can cause death, serious injury, or equipment failure.

To avoid death, serious injury, or equipment failure:

- Only use qualified electricians for carrying out the electrical installation.
- Disconnect the soft starter from all power sources before installation or service.
- Fit finger guards to all terminals, even if no cable is connected.
- Treat the bus bar and heat sink as live whenever the unit has mains voltage connected. Also take this precaution when the soft starter is tripped or waiting for a command.
- Follow the guidelines in these instructions and local electrical safety codes.

4 Installation

4.1 IP20 Protection for MCD 200, MCD5-0131B ~ MCD5-0215B, and MCD5-0245C

MCD 200 and MCD 500 (enclosure sizes G2 and G3C) models use rubber finger guards. Rubber finger guards provide IP20 protection when used with cable of diameter 22 mm or greater.

Installation

- Place 3 finger guards side by side in 1 retaining bracket. Align the assembly so that the screw holes in the bracket match the screw holes in the soft starter.
MCD 200 only: Remove the 2 top screws from the casing around the power terminals.
MCD 500 G3C enclosure size models only: Fit the finger guard base chassis to the MCD 500 enclosure first before installing rubber finger guards.
- Feed each power cable through the narrow end of each finger guard. Connect the cables to the appropriate terminals on the soft starter.
- If the cables do not fit through the finger guards, shorten the finger guards at the narrow end to make a bigger opening.
- Screw the retaining bracket to the soft starter.
MCD 200 only: Use the screws from step 1 to attach the retaining bracket to the soft starter casing.
MCD 500 G3C enclosure size models only: Fit the finger guard cover over the finger guard base chassis to complete the arrangement.
- Repeat steps 1–4 for the other set of terminals.

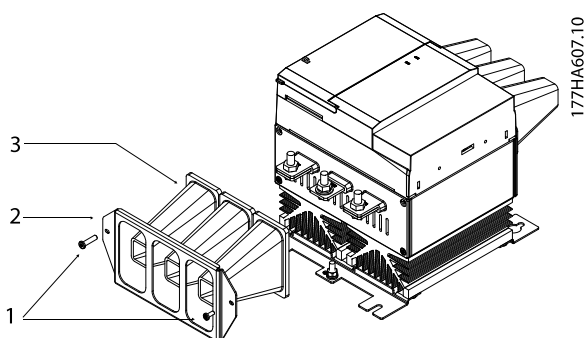

Illustration 4.1 Finger Guard Installation for MCD 200

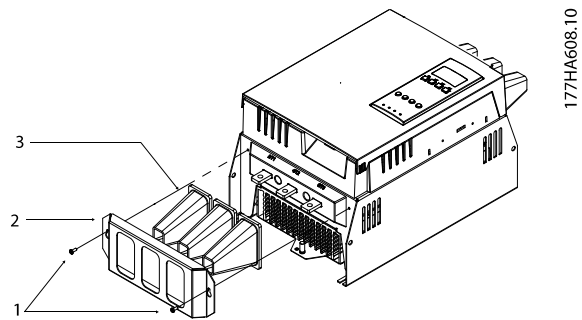
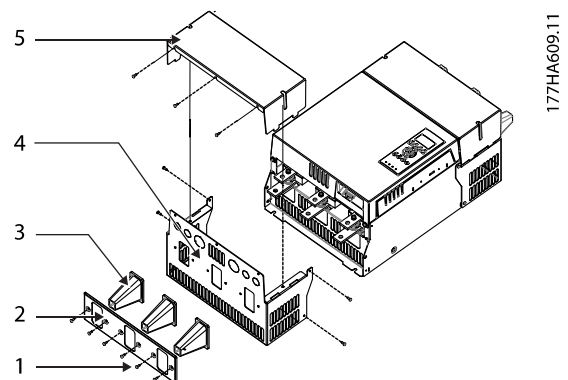

Illustration 4.2 Finger Guard Installation for MCD 500 G2 Enclosure Size

1	Screws
2	Retaining bracket
3	Finger guards

Table 4.1 Legend to *Illustration 4.1* and *Illustration 4.2*



1	Screws
2	Retaining bracket
3	Finger guards
4	Finger guard base chassis
5	Top cover

Illustration 4.3 Finger Guard Installation for MCD 500 G3C Enclosure Size

4.2 IP20 Protection for MCD5-0245B ~ MCD5-0961B

MCD 500 (enclosure sizes G3B and G4B) models use rubber finger guards. Rubber finger guards provide IP20 protection when used with cable of diameter 22 mm or greater.

Installation

1. MCD5-0245B ~ MCD5-0396B: Screw the finger guard plate to the base of the soft starter.
MCD5-0469B ~ MCD5-0961B: Screw the finger guard bracket to the enclosure of the soft starter.
2. Fit 1 polycarbonate retaining bracket over each finger guard.
3. Feed each power cable through the narrow end of each finger guard. Connect the cables to the appropriate terminals on the soft starter.
4. If the cables do not fit through the finger guards, shorten the finger guards at the narrow end to make a bigger opening.
5. Screw each retaining bracket to the finger guard plate/bracket.
6. MCD-50469B ~ MCD5-0961B: Fit the finger guard cover over the bracket to complete the arrangement.
7. Repeat steps 1–6 for the other set of terminals.

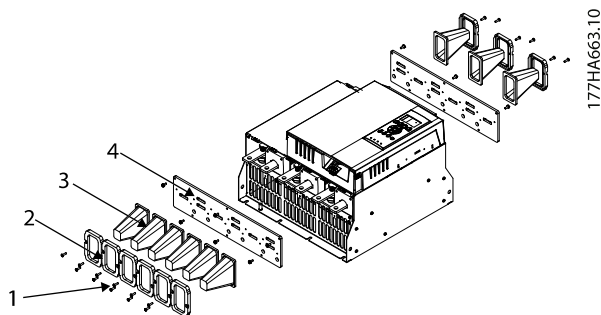

1	Screws
2	Retaining bracket
3	Finger guards
4	Finger guard plate

Illustration 4.4 Finger Guard Installation for MCD 500 G3B Enclosure Size

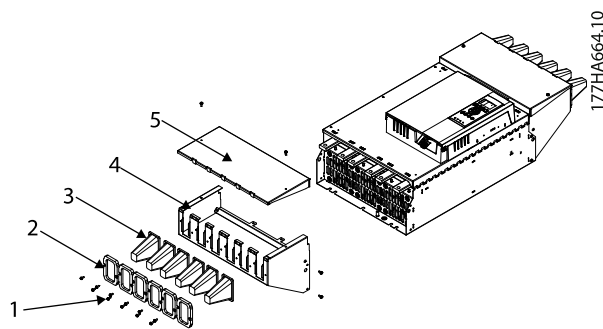

1	Screws
2	Retaining bracket
3	Finger guards
4	Finger guard bracket
5	Top cover

Illustration 4.5 Finger Guard Installation for MCD 500 G4B Enclosure Size

4.3 IP20 Protection for MCD5-360C ~ MCD5-1600C

MCD 500 enclosure sizes G4C and G5C use finger guard chassis enclosures to isolate live bus bars.

NOTICE

Each kit is only sufficient for protection of either top or bottom cable terminals. If both top and bottom cable termination is used, 2 finger guard kits are required.

Installation

1. Fasten the finger guard base chassis to the main enclosure of the soft starter using the screws provided.
2. Drill power cable access holes into the gland plate using the pilot holes provided. To prevent excessive heating of the gland plate due to large eddy currents, cut horizontal slits between the power cable holes drilled into the gland plate.
3. Fit the gland plate to the finger guard base chassis using the screws provided.
4. Run the power cables through the holes in the gland plate and connect to the appropriate bus bar terminals of the soft starter. To prevent fraying of cables against the gland plate, fit cable bushes or glands (not supplied) appropriate for the size of cable used.
5. Fit the finger guard cover over the finger guard base chassis to complete the arrangement.
6. Repeat steps 1–5 for the other set of terminals.

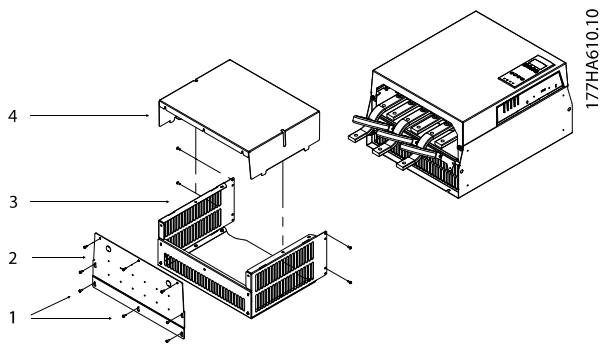

Illustration 4.6 Finger Guard Installation for MCD 500 G4C Enclosure Size

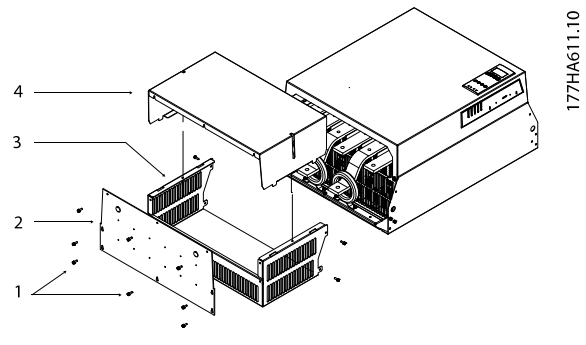
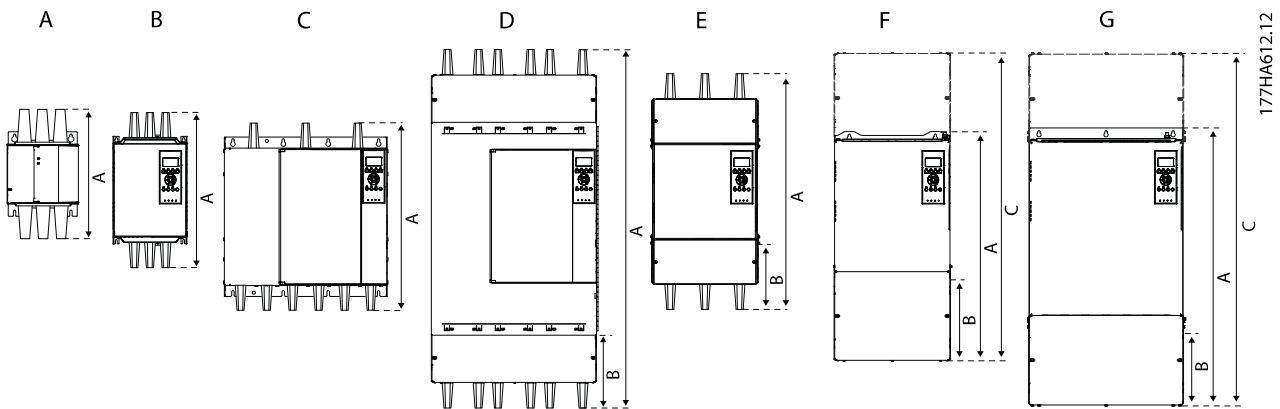

Illustration 4.7 Finger Guard Installation for MCD 500 G5C Enclosure Size

1	Screws
2	Gland plate
3	Finger guard base chassis
4	Finger guard cover

Table 4.2 Legend to *Illustration 4.6* and *Illustration 4.7*

4.4 Built-up Dimensions



	A	B	C	D	E	F	G
	MCD 200	MCD 500, G2	MCD 500, G3B	MCD 500, G4B	MCD 500, G3C	MCD 500, G4C	MCD 500, G5C
A [mm (in)]	367 (14.4)	577 (22.7)	567 (22.3)	1161 (45.7)	878 (34.6)	853 (33.6)	1036 (40.8)
B [mm (in)]	-	-	-	300 (11.8)	261 (10.3)	308 (12.1)	286 (11.3)
C [mm (in)]	-	-	-	-	-	1146 (45.1)	1319 (51.9)

Illustration 4.8 Dimensions

4.5 Packing List

175G9007	175G5662	175G5730	175G5731
MCD 200 ¹⁾	MCD 500 G2 enclosure size ¹⁾	MCD 500 G3B enclosure size ¹⁾	MCD 500 G4B enclosure size ¹⁾
6 finger guards (rubber)	6 finger guards (rubber)	9 finger guards (rubber)	12 finger guards (rubber)
2 retaining brackets	2 retaining brackets	9 retaining brackets	12 retaining brackets
1 installation instructions	4 M4x10 screws	2 finger guard plates	2 finger guard bracket
–	6 cable ties	18 M4x14 screws	2 finger guard cover
–	1 installation instructions	12 M4x12 screws	24 M4x16 screws
–	–	1 installation instructions	12 M4x12 screws
–	–	–	1 installation instructions

Table 4.3 Packing List MCD 200, MCD 500 Enclosure Size G2, MCD 500 Enclosure Size G3B, and MCD 500 Enclosure Size G4B

175G5663	175G5664	175G5665
MCD 500 G3C enclosure size ²⁾	MCD 500 G4C enclosure size ²⁾	MCD 500 G5C enclosure size ²⁾
3 finger guards (rubber)	1 finger guard grille	1 finger guard grille
1 finger guard cover	1 finger guard cover	1 finger guard cover
1 finger guard chassis	1 finger guard base chassis	1 finger guard chassis
1 clamp plate	2 finger guard side chassis	1 gland plate
11 M4x10 screws	1 gland plate	12 M4x10 screws
1 installation instructions	6 M4x10 screws	1 installation instructions
–	12 M4x16 screws	–
–	2 M4 nuts	–
–	1 installation instructions	–

Table 4.4 Packing List MCD 500 Enclosure Size G3C, MCD 500 Enclosure Size G4C, and MCD 500 Enclosure Size G5C

1) Only 1 kit required.

2) Each kit is only sufficient for protection of either top or bottom cable terminals. If both top and bottom cable termination is used, 2 finger guard kits are required.

.....
Danfoss can accept no responsibility for possible errors in catalogues, brochures and other printed material. Danfoss reserves the right to alter its products without notice. This also applies to products already on order provided that such alterations can be made without subsequential changes being necessary in specifications already agreed. All trademarks in this material are property of the respective companies. Danfoss and the Danfoss logotype are trademarks of Danfoss A/S. All rights reserved.
.....

Danfoss A/S
Ulsnaes 1
DK-6300 Graasten
vlt-drives.danfoss.com

MI17A602



* M I 1 7 A 6 0 2 *

04/2016