

VLT® General Purpose I/O MCB 101

VLT® AutomationDrive FC 361

1 Overview

1.1 Introduction

This instruction describes the VLT® General Purpose I/O MCB 101 for use in the VLT® AutomationDrive FC 361, expanding the number of inputs/outputs in the drive.

The VLT® General Purpose I/O MCB 101 includes 3 digital inputs, 2 analog inputs, 2 digital outputs, and 1 analog output.

1.2 Items Supplied

- VLT® General Purpose I/O MCB 101.

2 Safety

2.1 Safety Precautions

⚠ WARNING ⚠

DISCHARGE TIME

The drive contains DC-link capacitors, which can remain charged even when the drive is not powered. High voltage can be present even when the warning indicator lights are off.

Failure to wait the specified time after power has been removed before performing service or repair work could result in death or serious injury.

- Stop the motor.
- Disconnect AC mains, permanent magnet type motors, and remote DC-link supplies, including battery back-ups, UPS, and DC-link connections to other drives.
- Wait for the capacitors to discharge fully. The minimum waiting time is specified in table *Discharge time* and is also visible on the nameplate on top of the drive.
- Before performing any service or repair work, use an appropriate voltage measuring device to make sure that the capacitors are fully discharged.

Table 1: Discharge Time

Voltage [V]	Power range [kW (hp)]	Minimum waiting time (minutes)
380–480	90–315 kW (125–450 hp)	20

3 General Technical Data

3.1 Galvanic Isolation

Digital/analog inputs are galvanically isolated from other inputs/outputs on the VLT® General Purpose I/O MCB 101 and in the control card of the drive.

Digital/analog outputs in the VLT® General Purpose I/O MCB 101 are galvanically isolated from other inputs/outputs on the VLT® General Purpose I/O MCB 101, but not from those on the control card of the drive.

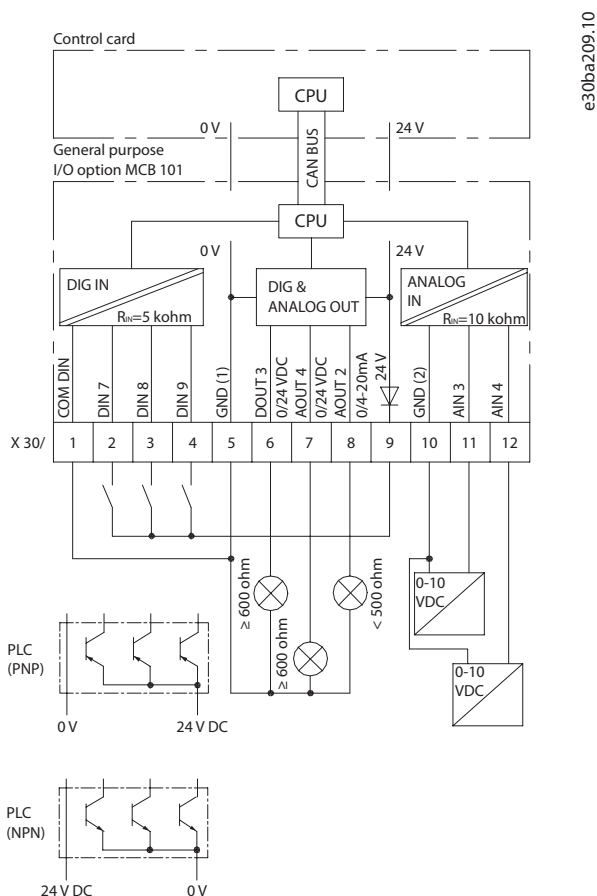

e30ba209.10

Illustration 1: Principle Diagram

3.2 Digital Inputs - Terminal X30/1-4

Parameters for set-up: parameter 5-16 Terminal X30/2 Digital Input, parameter 5-17 Terminal X30/3 Digital Input, and parameter 5-18 Terminal X30/4 Digital Input.

Table 2: Technical Data of Digital Inputs

Number of digital inputs	Voltage level	Voltage levels	Input impedance	Maximum load
3	0–24 V DC	PNP type: Common = 0 V Logic 0: input < 5 V DC Logic 0: input > 10 V DC NPN type: Common = 24 V Logic 0: input > 19 V DC Logic 0: input < 14 V DC	Approximately 5 kΩ	± 28 V continuous ± 37 V in minimum 10 s

3.3 Analog Voltage Inputs - Terminal X30/10-12

Parameters for set-up: parameter group 6-3* Analog Input 3, parameter group 6-4* Analog Input 4, and parameter 16-75 Analog In X30/11.

Table 3: Technical Data of Analog Voltage Inputs

Number of analog voltage inputs	Standardized input signal	Input impedance	Resolution	Maximum load
2	0–10 V DC	Approximately 5 kΩ	10 bits	± 20 V continuously

3.4 Digital Outputs - Terminal X30/5-7

Parameters for set-up: parameter 5-32 Term X30/6 Digi Out (MCB 101) and parameter 5-33 Term X30/7 Digi Out (MCB 101).

Table 4: Technical Data of Digital Outputs

Number of digital outputs	Output level	Tolerance	Maximum load
2	0 or 24 V DC	± 4 V	≥ 600 Ω

3.5 Analog Outputs - Terminal X30/5+8

Parameters for set-up: parameter group 6-6* Analog Output 2 and parameter 16-77 Analog Out X30/8 [mA].

Table 5: Technical Data of Analog Outputs

Number of analog outputs	Output signal level	Tolerance	Maximum load
1	0/4–20 mA	± 0.1 mA	< 500 Ω

4 Installation

4.1 Mounting the Control Cables

Procedure

1. Make sure that the power to the drive is disconnected.
2. Remove the front cover from the drive.
3. Remove the LCP (local control panel) or blind cover, and then remove the LCP cradle from the drive.
4. Fit the VLT® General Purpose I/O MCB 101 option card into slot B.
5. Connect the control cables and relieve the cable by the enclosed cable strips.

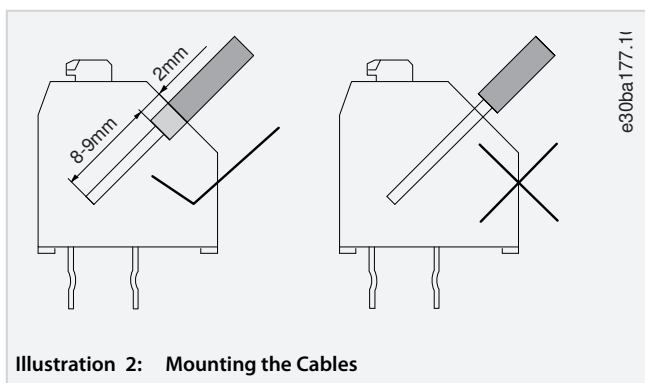

6. Remove the knock out in the LCP cradle, so that the option fits under the LCP cradle.
7. Fit the LCP cradle.
8. Fit the LCP or blind cover in the LCP cradle.
9. Fit the front cover on the drive.
10. Connect power to the drive.
11. Set up the input/output functions in the corresponding parameters according to the technical data.

.....
Danfoss can accept no responsibility for possible errors in catalogues, brochures and other printed material. Danfoss reserves the right to alter its products without notice. This also applies to products already on order provided that such alterations can be made without subsequential changes being necessary in specifications already agreed. All trademarks in this material are property of the respective companies. Danfoss and the Danfoss logotype are trademarks of Danfoss A/S. All rights reserved.
.....

Danfoss A/S
Ulsnaes 1
DK-6300 Graasten
vlt-drives.danfoss.com

