

1 Master/ Follower Operation

1

1.1.1 Abstract

The following Application Note covers a Master/Follower Water Distribution System, where the goal is to maintain a constant pressure. The intention is to create a guideline for the needed considerations regarding installation and provide typical settings, when using a Danfoss VLT® AQUA Drive.

1.1.2 Master/ Follower Operation

Application Description

The system used as example contains 4 equal sized pumps in a water distribution system. They are each connected to a Danfoss VLT® AQUA Drive. A pressure transmitter with an analogue output format of 4-20mA is used as feedback and connected to the drive named the 'master drive'. The master drive also includes the Danfoss *VLT® Extended Cascade Controller Option MCO-101*. The purpose of the system is to maintain a constant pressure in the system.

Arguments for using a 'master / follower' setup instead of the standard cascade control mode could be:

- In old and weak pipe system where huge pressure surges can lead to leakage, the high performance of the master / follower mode can be a real benefit.
- In constant pressure water systems the pumps can be operated in the most energy efficient way by using Master / follower operation.
- In systems with large variances in flow, the fast reacting Master / Follower mode will safely and fast maintain a constant pressure.
- Very easy installation - no need for external equipment. The drives can be delivered in IP55 or even IP66, which means no need for panels, except for fuses.

Issues to keep in mind

Compared to traditional cascade control the number of running pumps is controlled by speed instead of feedback. To obtain the highest energy saving the stage on and off speed must be set correctly according to the system. To understand the principle better, please note figure 1.

The stage on and off speed is set by the user for each stage. The right speed depends on the application and the system. In VLT® AQUA software version higher than 1.1, the speed will be auto-tuned by the drive. The right settings can also be determined by using the Danfoss PC software called MUSEC, which is downloadable from our homepage: www.danfoss.com

For a start the settings showed in table 1.1 can be used in most applications.

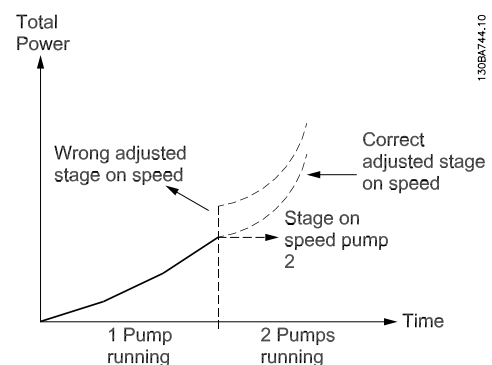

Illustration 1.1: Total power consumption.

1

	Stage on speed [Hz] (Par. 27-32)	Stage off speed [Hz] (Par. 27-34)
Stage 1	40	Min. speed
Stage 2	44	38
Stage 3	46	40
Stage 4	48	42

Table 1.1: Example of stage on and stage off speed

Electrical wiring

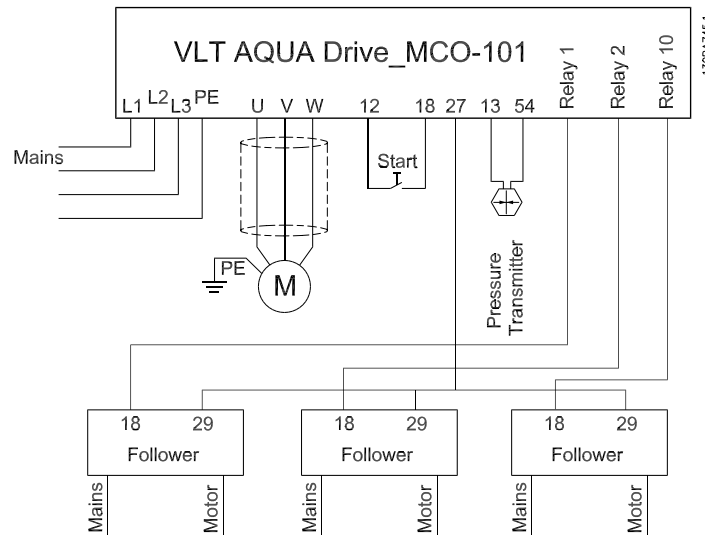



Illustration 1.2: Electrical wiring. Terminal 27 on master drive is used as pulse output reference. Terminal 29 on the follower drives is used as pulse input reference. All follower drives are connected to mains and motor the same way as the master drive symbolized with the text: *Mains* and *Motor*.

NB!
In the example it is assumed that the pressure transmitter used as feedback sensor, has a range from 0-10 bar.

Parameter settings:

Display settings - Master drive:		
Display Line 1.1 Small	0-20	Reference [1601]
Display Line 1.2 Small	0-21	Feedback [1652]
Display Line 1.3 Small	0-22	Motor current [1614]
Display Line 2 Large	0-23	Frequency [1613]
Display Line 3 Large	0-24	Cascade reference [2791]

Display settings - Follower drives:		
Display Line 1.1 Small	0-20	External Reference [1650]
Display Line 3 Large	0-24	Frequency [1613]

 **NB!**
Please note: the format of the analogue input is set using switch S201 below the LCP.

Basic settings for both Master and Follower drives:

Parameters:	
Change from RPM to Hz as speed unit	0-02
Motor rated power	1-20 / par. 1-21 (kW / HP)
Motor rated voltage	1-22
Motor Current	1-24
Motor Rated Speed	1-25
Motor Rotation Check	1-28 Check rotation direction
Enable Automatic Motor Adaptation	1-29

Ramp Up Time	3-41	(5 sec.* Depending on size) Must be the same in Master and Follower!
Ramp Down Time	3-42	(5 sec.* Depending on size) Must be the same in Master and Follower!
Motor Speed Low Limit [Hz]	4-12	(30 Hz)
Motor Speed High Limit [Hz]	4-14	(50 Hz) Must be the same in Master and Follower!

Settings for the Master drive only

1. Use the *Closed Loop Wizard* under *Quick Menu_Function Setup*, to easily set up the feedback settings and the PID controller.
2. Set up the master configuration in par. 27-**

Configuration mode	27-10	Master/Follower
Set number of drives	27-11	4
Set the staging speed according to table 1.1	27-3*	
Configure Relay 1	27-70	Drive 2 Enable
Configure Relay 2	27-70	Drive 3 Enable
Configure Relay 10	27-70	Drive 4 Enable
Minimum Reference	3-02	0 [bar]
Maximum Reference	3-03	10 [bar]
Terminal 27 Mode	5-01	Output [1]
Terminal 27 Digital Output	5-30	Pulse output [55]
Terminal 27 Pulse Output Variable	5-60	Cascade Reference [116]
Pulse Output Maximum Frequency # 27	5-62	5000 [Hz]

Settings for the Follower drives only

Set Reference 1 Source	3-15	Pulse input 29 [7]
Set Terminal 29 Digital Input	5-13	Pulse input [32]
Set Term. 29 Low Frequency	5-50	0 [Hz]
Set Term. 29 high frequency	5-51	5000 [Hz]

Autotuned Stage on/ off Speeds

If stage on/off autotune is enabled in P27-30, the speed in table 1.1 will be auto optimised during operation and ensure optimised performance.

1**Operation**

When the system is set to operation, the master drive will automatically run *time balance* with all drives running with the needed number of pumps depending on the demand. If, for some reason the user wants to prioritize which motors should be preferred, it is possible to prioritize the pumps in par. 27-16 in three levels. (Priority 1, Priority 2 and spare pump). Pumps with priority 2 will only be staged on when there is no priority 1 pump available.

It might be necessary to fine adjust the *stage on/off* speed to optimise the energy consumption, if not auto tuned.