

# VLT® Real-time Clock MCB 117

VLT® HVAC Drive FC 102, VLT® Refrigeration Drive FC 103, VLT® AQUA Drive FC 202, VLT® Automation Drive FC 301/FC 302

## 1 Scope of Delivery, Safety, and Installation

### 1.1 Purpose of the Option

Use the VLT® Real-time Clock MCB 117 for the standard clock function in the drive. The option has back-up battery and the drive uses it for synchronizing real-time data.

### 1.2 Items Supplied

- VLT® Real-time Clock MCB 117.

The MCB 117 is only available in a coated version.

Table 1: Ordering Number

Version	Ordering number
Coated	134B6544

### 1.3 Safety Instructions

For important information about safety precautions for installation, refer to the product-specific operating guide.

**⚠ WARNING ⚠**

**DISCHARGE TIME**

The drive contains DC-link capacitors, which can remain charged even when the drive is not powered. High voltage can be present even when the warning indicator lights are off.

Failure to wait the specified time after power has been removed before performing service or repair work could result in death or serious injury.

- Stop the motor.
- Disconnect AC mains, permanent magnet type motors, and remote DC-link supplies, including battery back-ups, UPS, and DC-link connections to other drives.
- Wait for the capacitors to discharge fully. The minimum waiting time is specified in the table *Discharge time* and is also visible on the nameplate on top of the drive.
- Before performing any service or repair work, use an appropriate voltage measuring device to make sure that the capacitors are fully discharged.

**Table 2: Discharge Time, VLT® HVAC Drive FC 102 and VLT® Refrigeration Drive FC 103**

Voltage [V]	Minimum waiting time (minutes)		
	4	7	15
200–240	1.1–3.7 kW (1.5–5 hp)	–	5.5–45 kW (7.5–60 hp)
380–480	1.1–7.5 kW (1.5–10 hp)	–	11–90 kW (15–125 hp)
525–600	1.1–7.5 kW (1.5–10 hp)	–	11–90 kW (15–125 hp)
525–690	–	1.1–7.5 kW (1.5–10 hp) (FC 102 only)	11–90 kW (15–125 hp) (FC 102 only)

**Table 3: Discharge Time, VLT® AQUA Drive FC 202**

Voltage [V]	Minimum waiting time (minutes)		
	4	7	15
200–240	0.25–3.7 kW (0.34–5 hp)	–	5.5–45 kW (7.5–60 hp)
380–480	0.37–7.5 kW (0.5–10 hp)	–	11–90 kW (15–125 hp)
525–600	0.75–7.5 kW (1.0–10 hp)	–	11–90 kW (15–125 hp)
525–690	–	1.1–7.5 kW (1.5–10 hp)	11–90 kW (15–125 hp)

**Table 4: Discharge Time, VLT® AutomationDrive FC 301/FC 302**

Voltage [V]	Minimum waiting time (minutes)		
	4	7	15
200–240	0.25–3.7 kW (0.34–5 hp)	–	5.5–37 kW (7.5–50 hp)
380–500	0.25–7.5 kW (0.34–10 hp)	–	11–75 kW (15–100 hp)
525–600	0.75–7.5 kW (1–10 hp)	–	11–75 kW (15–100 hp)
525–690	–	1.5–7.5 kW (2–10 hp)	11–75 kW (15–100 hp)

## 1.4 Installing the D-Option

### Prerequisites:

The following tools are required for installing the option:

- Torx 10 screwdriver.
- Flat-head screwdriver.

### Procedure

1. Disconnect power to the drive.
  2. Disconnect power to the live part connections on the relay terminals.
  3. Remove the LCP or the blind cover.
  4. Remove the terminal cover.
  5. Remove the control cables.
  6. Remove the cable decoupling plate.
- For enclosure sizes A2 and A3, also remove the plastic cover underneath the decoupling plate (if installed).
7. Insert the option in the D-option slot.
  8. Mount the cable decoupling plate.
  9. Connect the control cables and relieve the cables with the enclosed cable strips.
  10. Attach the terminal cover and the LCP, or the blind cover.
  11. Connect power to the drive.

### Example:

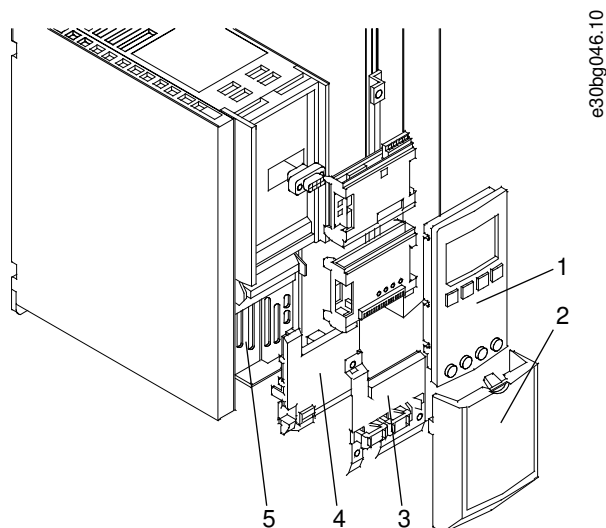

e30bg046.10

1 LCP	2 Terminal cover
3 Cable decoupling plate	4 D-option
5 D-option slot	

Illustration 1: Installing a D-Option in an A2/A3 Enclosure

## 1.5 Option Identification

If the option is mounted in the drive, *parameter 15-60 Option Mounted* shows the type code D1.

## 1.6 Time Synchronization

Set the time for daily date and time synchronization with the drive via *parameter 0-70 Date and Time*.

## 1.7 Fieldbus Synchronization

### NOTICE

*Parameter 0-84 Time for Fieldbus* can only be accessed via fieldbus.

It is possible to synchronize date and time via fieldbus. Access *parameter 0-84 Time for Fieldbus* to set the time for the synchronization to take place.



.....  
Danfoss can accept no responsibility for possible errors in catalogues, brochures and other printed material. Danfoss reserves the right to alter its products without notice. This also applies to products already on order provided that such alterations can be made without subsequential changes being necessary in specifications already agreed. All trademarks in this material are property of the respective companies. Danfoss and the Danfoss logotype are trademarks of Danfoss A/S. All rights reserved.  
.....

Danfoss A/S  
Ulsnaes 1  
DK-6300 Graasten  
vlt-drives.danfoss.com

